



# BATTERY & SUPERCAPACITOR LED-BLDC MOTOR DRIVE IN EV APPLICATIONS

<sup>1</sup>Shreyas Andi, <sup>2</sup>Mohammed Abdul Moyeed, <sup>3</sup>Kalyanam Vamshi

<sup>1</sup>Student, <sup>2</sup>Student, <sup>3</sup> Student

<sup>1</sup>Electrical and Electronics Engineering,

<sup>1</sup>Sreenidhi Institute of Science and Technology, Hyderabad, India

**Abstract:** This paper examines the feasibility and capability of a hybrid energy storage system (HESS) composed of battery and super-capacitor units, through simulation. Extensive use of internal combustion engine (ICE) - based vehicles has contributed to severe adverse impacts on the environment and accelerated depletion of fossil fuel reserves, leading to considerable rise in price of gas over the past two decades. These challenges, plus the low efficiency associated with the conventional drivetrains, have made the automotive industry seriously consider and move towards drivetrain electrification in vehicular systems. In electrified vehicles, the propulsion is fully or partially provided by electric motors, powered by on board energy storage systems. To make up for the limitations of the existing energy storage devices and contribute to vehicle electrification movement, the choice of HESS topology has been made based on simplicity of power and control circuits. cost and performance. The design takes into consideration the required power, the converter losses, limitations of energy storage devices, and quality of the current

**Keywords:** Super capacitor, Power Converter, Brushless DC Motor, battery.

## I. INTRODUCTION

EVs- have been a transportation mainstay because the workplace and housing areas in most of these densely populated cities are within walking or cycling distance. This reliable yet overlooked form of transportation has evolved over the years from simple utility bicycles to powerful geared mountain bikes and now electric assisted bicycles. Environmental concerns in terms of emissions and depleting fuel reserves have revived the electric vehicle industry and research community. Electric assisted bicycles still retain the characteristics of a conventional bicycle with an added advantage of extra power, say when riding up a hill. This enables the elderly or not so physically fit people to still enjoy riding a bicycle up a slope. Batteries are the weak link at the moment for any electrically propelled vehicle including the bicycle. The lack of a single reasonably priced energy storage device that can simultaneously provide high power density and high energy density has been the main stumbling block to the acceptance of electric propulsion as the main form of private and public transportation.

Presently the only viable solution to this problem is to combine a high energy storage device such as an electrochemical battery or fuel cell with a high-power device such as an Electric Double Layer Capacitor (EDLC) or ultra-capacitor or more often called a super capacitor. Usually, some form of power converter executing an energy management control technique is used to interface the battery bank and super capacitor array to the load bus. It is the aim of this research work to design a smart power converter with a heuristic based energy management technique which will optimize the power flow from the battery pack to the load. As the name implies, a super capacitor is a capacitor with capacitance greater than any other, usually in

excess of up to 3400 Farad. Super capacitors do not have a traditional dielectric material like ceramic, polymer films or aluminium oxide to separate the electrodes instead a physical barrier made of activated carbon. A double electric field which is generated when charged, acts a dielectric. The surface area of the activated carbon is large thus allowing for the absorption of large number of ions.

### *Advantages of Super capacitors:*

- Cell voltage determined by the circuit application not limited by cell chemistry.
- Very high cell voltages possible
- High power density
- Can withstand extreme temperatures.
- Simple charging methods
- Very fast charge and discharge
- Overcharging is not possible.
- Long life cycle
- Low impedance

## II. LITERATURE SURVEY

**K. Zhuge et al.**, Extensive use of internal combustion engine (ICE)- based vehicles has contributed to severe adverse impacts on the environment and accelerated depletion of fossil fuel reserves, leading to considerable rise in price of gas over the past two decades. These challenges, plus the low efficiency associated with the conventional drivetrains, have made the automotive industry seriously consider and move towards drivetrain electrification in vehicular systems. In electrified vehicles, the propulsion is fully or partially provided by electric motors, powered by onboard energy storage systems. In an attempt to make up for the limitations of the existing energy storage devices and contribute to vehicle electrification movement, this paper examines the feasibility and capability of a hybrid energy storage.

system (HESS), composed of battery and ultra-capacitor units, through simulation and experimentation using a laboratory prototype. The choice of HESS topology has been made based on simplicity of power and control circuits, cost and performance. The design takes into consideration the required power, the converter losses, limitations of energy storage devices, and quality of the current drawn from battery cells. Experimental results are provided to verify the analytical expectations and simulation results.

### *Summary:*

In an attempt to make up for the limitations of the existing energy storage devices and contribute to vehicle electrification movement, this paper examines the feasibility and capability of a hybrid energy storage system (HESS), composed of battery and ultra-capacitor units, through simulation.

**Bhim Singh et al.**, In this paper, a solar PV (Photovoltaic) array, a battery energy storage (BES), a diesel generator (DG) set and grid-based EV charging station (CS) is utilized to provide the incessant charging in islanded, grid connected, and DG set connected modes. The charging station is primarily designed to use the solar photovoltaic PV array and a BES to charge the electric vehicle (EV) battery. However, in case of exhausted storage battery and unavailable solar PV array generation, the charging station intelligently takes power from the grid or DG (Diesel Generator) set. However, the power from DG set is drawn in a manner that, it always operates at 80-85% loading to achieve maximum fuel efficiency under all loading conditions. Moreover, in coordination with the storage battery, the charging station regulates the generator voltage and frequency without a mechanical speed governor. It also ensures that the power drawn from the grid, or the DG set is at unity power factor (UPF) even at nonlinear loading. Moreover, the PCC (Point of Common Coupling) voltage is synchronized to the grid/ generator voltage to obtain the ceaseless charging. The charging station also performs the vehicle to grid active/reactive power transfer, vehicle to home and vehicle to vehicle power transfer for increasing the operational efficiency of the charging station. The

operation of the charging station is experimentally validated using the prototype developed in the laboratory.

### Summary:

in coordination with the storage battery, the charging station regulates the generator voltage and frequency without a mechanical speed governor. It also ensures that the power drawn from the grid, or the DG set is at unity power factor (UPF) even at nonlinear loading.

- A. Ostadi M. Kazerani** One of the key components of every Electric Vehicle (EV)/Hybrid Electric Vehicle (HEV) is the Energy Storage System (ESS). The most widely used ESS in electric drivetrains is based on batteries. As the specific power of batteries is normally low, they are hybridized with high-specific power storage elements such as ultra-capacitors in a Hybrid Energy Storage System (HESS) to meet harsh power requirements of the vehicle during acceleration and regenerative braking. This paper provides a thorough literature review on various configurations for interfacing battery and ultra-capacitor units to the DC bus forming a HESS in EV/HEV applications. It also reviews the energy management mechanisms used to split the power demand between battery and ultra-capacitor units.

### Summary:

This paper provides a thorough literature review on various configurations for interfacing battery and ultra-capacitor units to the DC bus forming a HESS in EV/HEV applications.

## III. PROPOSED METHOD

The proposed system implements bidirectional converters which are used to control voltages of super capacitor and battery.

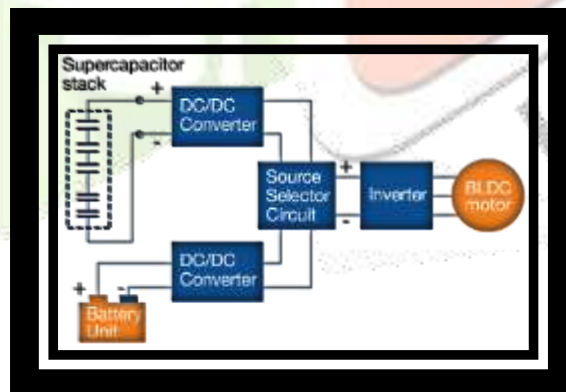


Figure 1. Flowchart of Proposed Method

The proposed method helps us to:

- Improve efficiency.
- Enhanced performance
- Extended Battery Life
- Quick Charging/Discharging

The process of max pooling is done by choosing the feature map region's maximum element.

### a) Design of a bi-direction converter

A buck converter (step-down converter) is a DC-to-DC power converter which steps down voltage (while stepping up current) from its input (supply) to its output (load). And the boost converter is used to step up the voltage.

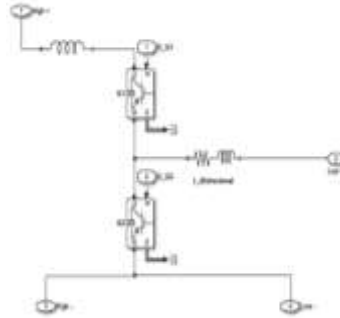


Figure 2. Bidirectional DC/DC Converter used in Battery & Super Capacitor

### b) Control strategy for bidirectional converter.

The bidirectional converters are used to control the battery and super capacitor voltage. BLDC motor connected at DC link through a bidirectional DC-DC converter is controlled in constant current/constant voltage (CC/CV). Until the terminal voltage of the EV battery reaches the voltage corresponding to the full charge condition, the EV charges in CC mode. However, after reaching near to the desired terminal voltage in nearly full charge condition, the charging of the EVs is shifted in CV mode. Here, the CC/CV mode of charging is controlled using two PI controllers as shown in Fig. 3.

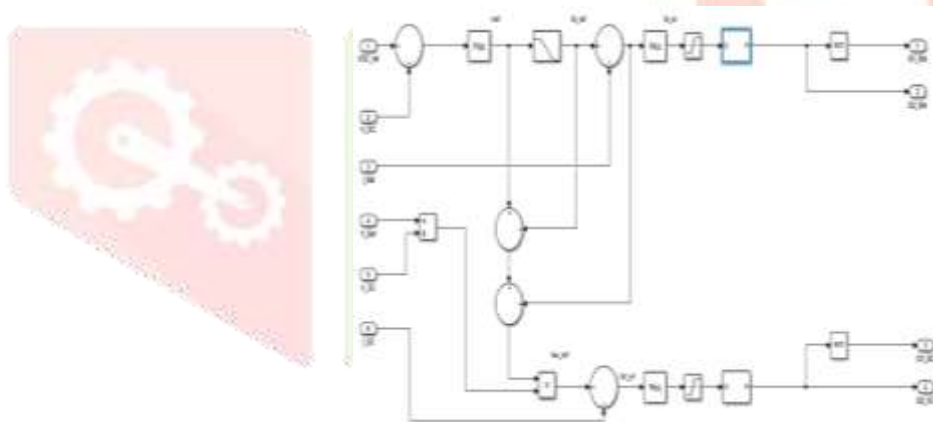


Figure 3. Battery & Super Capacitor Controlling Unit

Here the DC link voltage is compared with reference voltage and the error in voltage is provided to PI controller. After that the generated reference current is compared with battery current and the error is provided to PI controller. The generated reference voltage is provided to PWM generator to provide gate pulses for bidirectional converter at battery.

And to give pulses to bidirectional converter at SC the battery voltage is divided with SC voltage and then multiplied with generated reference current.

### c) Voltage source converter:

Single-phase VSIs are used primarily for low power range applications, while three-phase VSIs cover both medium and high power range applications.<sup>[4]</sup> Figure 5 shows the circuit schematic for a three-phase VSI.

Switches in any of the three legs of the inverter cannot be switched off simultaneously due to this resulting in the voltages being dependent on the respective line current's polarity. States 7 and 8 produce zero AC line

voltages, which result in AC line currents freewheeling through either the upper or the lower components. However, the line voltages for states 1 through 6 produce an AC line voltage consisting of the discrete values of  $V_i$ , 0 or  $-V_i$ .

For three-phase SPWM, three modulating signals that are 120 degrees out of phase with one another are used in order to produce out of phase load voltages. In order to preserve the PWM features with a single carrier signal, the normalized carrier frequency,  $m_f$ , needs to be a multiple of three. This keeps the magnitude of the phase voltages identical, but out of phase with each other by 120 degrees. The maximum achievable phase voltage amplitude in the linear region,  $m_a$  less than or equal to one, is  $v_{\text{phase}} = v_i / 2$ . The maximum achievable line voltage amplitude is  $V_{ab1} = v_{ab} \cdot \sqrt{3} / 2$

The only way to control the load voltage is by changing the input DC voltage.

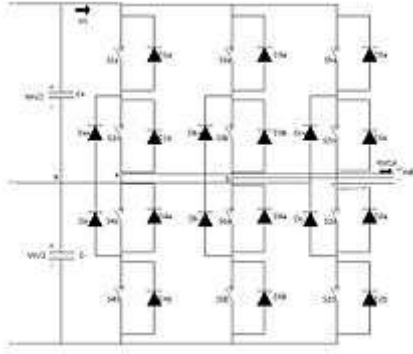


Figure 4. Three-Phase Voltage Source Inverter Circuit Schematic

#### d) Control of Voltage source Converter

In order to control the speed of electric vehicle that is BLDC motor, the speed is controlled through voltage source converter. By controlling dc link voltage, the VSC is controlled.

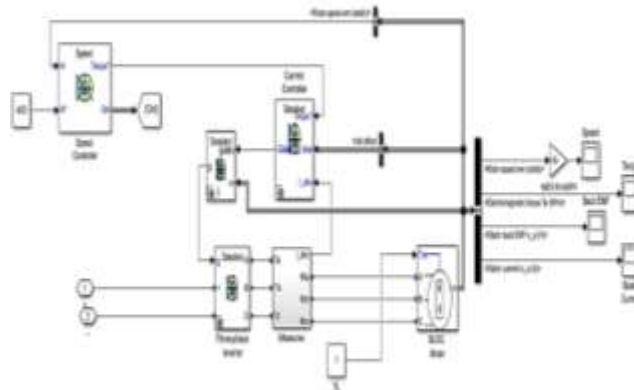


Figure 5. BLDC Motor & Inverter Controlling Unit

e) *Brushless DC electric motor*



Figure 5. *Brushless DC Electric Motor*

The motor from a 3.5" floppy disk drive. The coils, arranged radially, are made from copper wire coated with blue insulation. The rotor (upper right) has been removed and turned upside-down. The grey ring inside its cup is a permanent magnet.

Brushless DC electric motor (BLDC motors, BL motors) also known as electronically commutated motors (ECMs, EC motors) are synchronous motors that are powered by a DC electric source via an integrated inverter/switching power supply, which produces an AC electric signal to drive the motor. In this context, AC, alternating current, does not imply a sinusoidal waveform, but rather a bi-directional current with no restriction on waveform. Additional sensors and electronics control the inverter output amplitude and waveform (and therefore percent of DC bus usage/efficiency) and frequency (i.e. rotor speed).

The rotor part of a brushless motor is often a permanent magnet synchronous motor, but can also be a switched reluctance motor, or induction motor.

Brushless motors may be described as stepper motors; however, the term "stepper motor" tends to be used for motors that are designed specifically to be operated in a mode where they are frequently stopped with the rotor in a defined angular position. This page describes more general brushless motor principles, though there is overlap.

Two key performance parameters of brushless DC motors are the motor constants  $K_v$  and  $K_m$ .

f) *Brushless vs. brushed motors*

Brushed DC motors have been around since the mid-19th century, but brushless motors are a fairly recent arrival; a first step in the sixties thanks to advances in solid state technology,<sup>[1]</sup> with further improvements in the eighties thanks to better permanent magnet materials.

Brushed DC motors develop a maximum torque when stationary, linearly decreasing as velocity increases.<sup>[2]</sup> Some limitations of brushed motors can be overcome by brushless motors; they include higher efficiency and a lower susceptibility to mechanical wear. These benefits come at the cost of potentially less rugged, more complex, and more expensive control electronics.

A typical brushless motor has permanent magnets which rotate around a fixed armature, eliminating problems associated with connecting current to the moving armature. An electronic controller replaces the brush/commutator assembly of the brushed DC motor, which continually switches the phase to the windings to keep the motor turning. The controller performs similar timed power distribution by using a solid-state circuit rather than the brush/commutator system.

Brushless motors offer several advantages over brushed DC motors, including high torque to weight ratio, more torque per watt (increased efficiency), increased reliability, reduced noise, longer lifetime (no brush and commutator erosion), elimination of ionizing sparks from the commutator, and overall reduction of electromagnetic interference (EMI). With no windings on the rotor, they are not subjected to centrifugal forces, and because the windings are supported by the housing, they can be cooled by conduction, requiring no airflow inside the motor for cooling. This in turn means that the motor's internals can be entirely enclosed and protected from dirt or other foreign matter. Brushless motor commutation can be implemented

in software using a microcontroller or microprocessor computer, or may alternatively be implemented in analogue hardware, or in digital firmware using an FPGA. Commutation with electronics instead of brushes allows for greater flexibility and capabilities not available with brushed DC motors, including speed limiting, "micro stepped" operation for slow and/or fine motion control, and a holding torque when stationary. Controller software can be customized to the specific motor being used in the application, resulting in greater commutation efficiency.

The maximum power that can be applied to a brushless motor is limited almost exclusively by heat; too much heat weakens the magnets and may damage the winding's insulation.

When converting electricity into mechanical power, brushless motors are more efficient than brushed motors. This improvement is largely due to the brushless motor's velocity being determined by the frequency at which the electricity is switched, not the voltage. Additional gains are due to the absence of brushes, which reduces mechanical energy loss due to friction. The enhanced efficiency is greatest in the no-load and low-load region of the motor's performance curve. Under high mechanical loads, brushless motors and high-quality brushed motors are comparable in efficiency.

Environments and requirements in which manufacturers use brushless-type DC motors include maintenance-free operation, high speeds, and operation where sparking is hazardous (i.e. explosive environments) or could affect electronically sensitive equipment.

#### g) Variations in construction

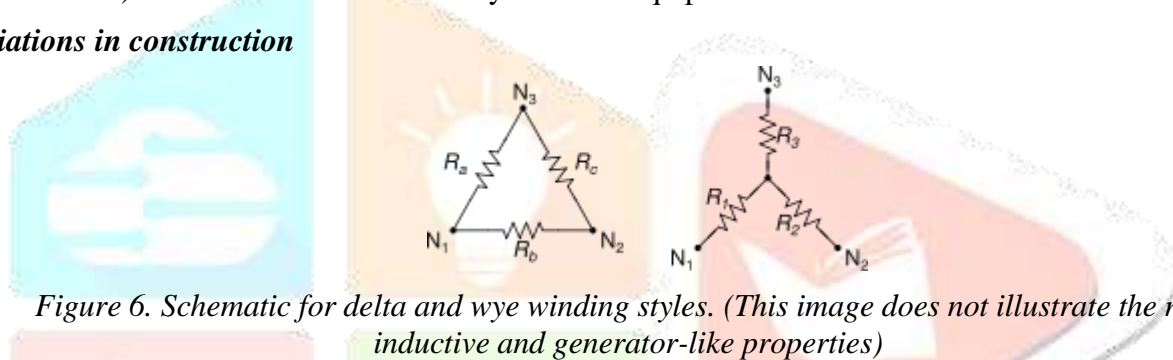


Figure 6. Schematic for delta and wye winding styles. (This image does not illustrate the motor's inductive and generator-like properties)

Brushless motors can be constructed in several different physical configurations: In the 'conventional' (also known as in runner) configuration, the permanent magnets are part of the rotor. Three stator windings surround the rotor. In the out runner (or external-rotor) configuration, the radial-relationship between the coils and magnets is reversed; the stator coils form the centre (core) of the motor, while the permanent magnets spin within an overhanging rotor which surrounds the core. The flat or axial flux type, used where there are space or shape limitations, uses stator and rotor plates, mounted face to face. Out runners typically have more poles, set up in triplets to maintain the three groups of windings, and have a higher torque at low RPMs. In all brushless motors, the coils are stationary.

There are two common electrical winding configurations; the delta configuration connects three windings to each other (series circuits) in a triangle-like circuit, and power is applied at each of the connections. The Wye (Y-shaped) configuration, sometimes called a star winding, connects all of the windings to a central point (parallel circuits) and power is applied to the remaining end of each winding.

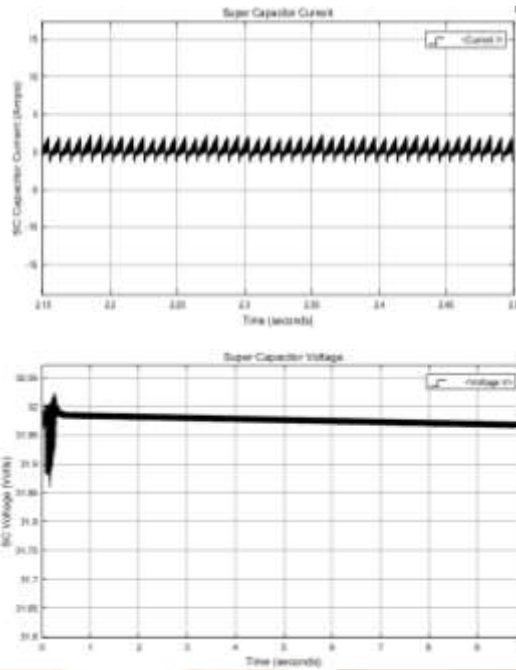
A motor with windings in delta configuration gives low torque at low speed but can give higher top speed. Wye configuration gives high torque at low speed, but not as high-top speed.

Although efficiency is greatly affected by the motor's construction, the Wye winding is normally more efficient. In delta-connected windings, half voltage is applied across the windings adjacent to the driven lead (compared to the winding directly between the driven leads), increasing resistive losses. In addition, windings can allow high-frequency parasitic electrical currents to circulate entirely within the motor. A Wye-connected winding does not contain a closed loop in which parasitic currents can flow, preventing such losses.

From a controller standpoint, the two styles of windings are treated exactly the same.

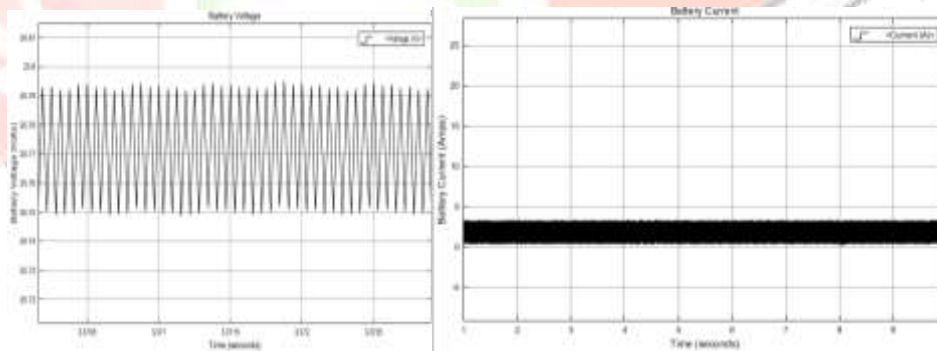
**IV.EXPERIMENTAL RESULTS**

**a) Voltage & Current Waveforms of Super Capacitor:**

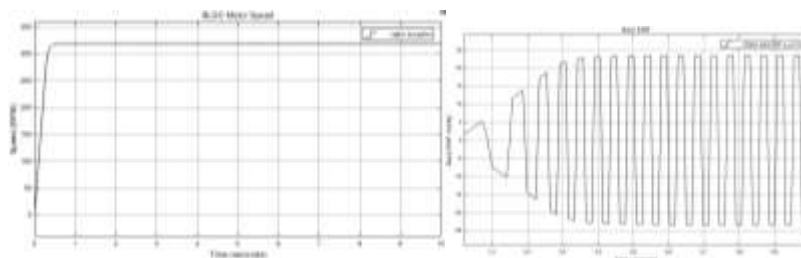


*Figure 7. Characteristics of Super Capacitor Voltage & Current*

**b) Voltage & Current Characteristics of a Battery :**



*Figure 8.Characteristics of Battery Voltage & Current*



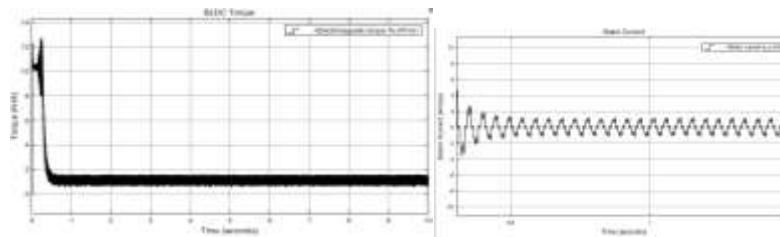


Figure 10. Speed, Torque, Back EMF, and Stator Current of BLDC Motor

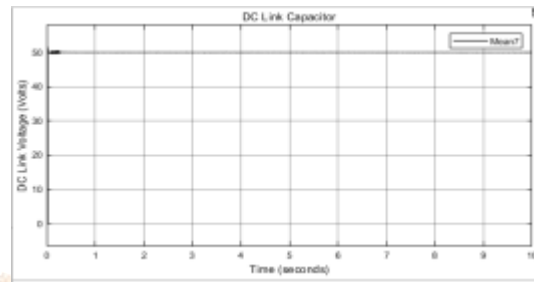


Figure 11. DC Link Capacitor Voltage

From the above figures, depicts the current and voltage waveforms with their respective time limits. The voltage at super capacitor is linearly decreasing from 32v to 31.96v, whereas the current waveform is having some distortions. Figure-7, depicts the battery's current and voltage waveforms. The current waveform is varying from 1 to 3 Amps and the voltage waveform is having linearly at 25.79V. Figure-8, depicts the waveforms of BLDC Motor speed, torque, back emf and stator current which are having the values of 317rpm, 1.6 N-m, the back emf ranges from -23.4 to 23.4 V and the stator currents ranges from -2 to 2A. Figure-9 depicts the DC link voltage at a value of 50v, which is known to be constant value.

## V. CONCLUSION

This research work has successfully implemented a battery and super capacitor hybrid power source for an electric assisted bicycle using state of the art hub motor technology. A power converter was designed and implemented based on the energy requirements of the system. Based on the implemented system experimental results show an improvement in the up-hill acceleration of the vehicle as a direct result of the power converter being responsive enough to harvest the extra current from the high power complementary super capacitor module avoiding deep discharges from the battery. This enhanced battery life. The maximum speed remained unchanged. The main battery pack was shielded from high discharge currents which would eventually enhance its life cycle.

## VI. REFERENCES

- [1] Alan. A Parker , Electric Power-Assisted Bicycles Reduce Oil Dependence and Enhance the Mobility of the Elderly electric power assisted vehicle. Presented at 29th Australian Transport Research Forum.
- [2] Don Tuite , "Get the Lowdown on Ultracapacitors", Technology report electronic design online , November 2007. URL: <http://electronicdesign.com/Articles/ArticleID/17465/17465.html>.
- [3] Adrian Schneuwly, Bobby Maher, Juergen Auer. "Ultracapacitors, the New Thinking in the Automotive World". Maxwell Technologies Inc.
- [4] Pay, S.; Baghzouz, Y.; , "Effectiveness of battery-supercapacitor combination in electric vehicles," Power Tech Conference Proceedings, 2003 IEEE Bologna , vol.3, no., pp. 6 pp. Vol.3, 23-26 June 2003

- [5] Dixon, J.W.; Ortuzar, M.E.; "Ultracapacitors + DCDC converters in regenerative braking system," Aerospace and Electronic Systems Magazine, IEEE , vol.17, no.8, pp. 16- 21, Aug 2002.
- [6] S. M. Lukic, J. Cao, R. C. Bansal, F. Rodriguez, and A. Emadi, "Energy Storage Systems for Automotive Applications," IEEE transactions on industrial electronics, vol. 55, no. 6, pp. 2258–2267, 2008.
- [7] J. Bauman, M. Kazerani, "A Comparative Study of Fuel-Cell – Battery , Fuel-Cell – Battery – Ultracapacitor Vehicles," IEEE transactions on vehicular technology, vol. 57, no. 2, pp. 760–769, 2008
- [8] B. Singh, A. Verma, A. Chandra and K. Al-Haddad, "Implementation of Solar PV-Battery and Diesel Generator Based Electric Vehicle Charging Station," in IEEE Int. Conf. Power Electronics, Drives and Energy Systems (PEDES), Chennai, India, 2018, pp. 1-6.
- [9] N. Saxena, B. Singh and A. L. Vyas, "Integration of solar photovoltaic with battery to single-phase grid," IET Generation, Transmission & Distribution, vol. 11, no. 8, pp. 2003-2012, 1 6 2017.
- [10] H. Razmi and H. Doagou-Mojarrad, "Comparative assessment of two different modes multi-objective optimal power management of microgrid: grid-connected and stand-alone," IET Renewable Power Generation, vol. 13, no. 6, pp. 802-815, 2019.
- [11] O. Erdinc, N. G. Paterakis, T. D. P. Mendes, A. G. Bakirtzis and J. P. S. Catalão, "Smart Household Operation Considering Bi-Directional EV and ESS Utilization by Real-Time Pricing-Based DR," IEEE Trans. Smart Grid, vol. 6, no. 3, pp. 1281-1291, May 2015.

