



Gas Leakage Detection System

¹Adarsh Kumar Singh, ²Harshada Bhapkar, ³Vaishnavi Budhwant, ⁴Sujata M. Patil

¹²³UG Student, ⁴Professor

Department of Electronics and Telecommunications, Imperial College of Engineering and Research, Pune, India

Abstract: Gas leakage is a critical safety concern in many industrial and domestic environments. This project involves the development of a gas leakage detection system utilizing Node MCU ESP8266 microcontroller and MQ5 gas sensor. The system is designed to detect the presence of harmful gases such as LPG, propane, and methane. Upon detection, the system triggers both visual and audible alarms through LED and a buzzer, at the respective levels of leakage, to alert occupants. Additionally, an exhaust fan is activated above the 80% of leakage to mitigate the gas concentration and enhance safety. The proposed system offers real-time monitoring capabilities through the Node MCU ESP8266 on ThinkSpeak open-source software, providing an effective solution for gas leakage detection and prevention.

Keywords – Esp8266, MQ-5 gas sensor, Buzzer, Led, Relay Module, Exhaust Fan, ThinkSpeak open-source .

I. INTRODUCTION

“Gas Leakage Detection System” is a project that can be used to reduce the threat to both life and property in various environments, including homes, industries, and commercial spaces[1].The consequences of undetected gas leaks can range from minor discomfort to catastrophic accidents. Therefore, the development of reliable gas leakage detection systems is imperative to ensure safety and prevent potential disasters.[2]

In response to this need, this project focuses on designing and implementing a gas leakage detection system using Node MCU ESP8266 microcontroller and MQ5 gas sensor. The system aims to detect the presence of hazardous gases such as LPG, propane, and methane, which are commonly used in households and industrial settings[3].

In this system, all sensors are triggered at specific levels of gas leakage. The moment gas sensor (MQ-5) starts detecting the leakage it will give signals to the Esp8266 of leakage. Then Esp8266 monitors the leakage, as the level increases to 20%-40%, then led stars flashing and gives an indication of the leakage. After that, as the leakage increases to 40%-60%, then the buzzer also starts buzzing with led and if the leakage increases above 80%, then Esp8266 will trigger the relay module, and it will run the exhaust fan to clear the leakage gas from the room or space.

By leveraging the capabilities of the Node MCU ESP8266, the system offers a real-time monitoring feature, enhancing its usability and effectiveness. And this real-time monitoring is accessible on open-source software(ThinkSpeak) from anywhere in the world. In the event of gas detection, the system triggers visual and audible alarms through LEDs and a buzzer, respectively, to alert occupants. Additionally, an exhaust fan is activated to facilitate the dispersion of the gas and minimize its concentration, further mitigating the risk of harm.

This project not only addresses the pressing need for gas leakage detection but also demonstrates the integration of emerging technologies to develop innovative solutions for safety and security in various environments.

II. PROBLEM STATEMENT

To provide a system that can ensure the safety of occupants, reduce the risk of accidents, from industrial to households facilities. And promote peace of mind in a wide range of environments.

III. MOTIVATION

The motivation behind this project stems from the pressing need to address the pervasive risk posed by gas leaks in both residential and industrial settings. Gas leakage incidents can lead to devastating consequences, including fires, explosions, and loss of life. Despite the availability of conventional gas detection systems, there is a demand for more advanced and accessible solutions that offer real-time monitoring accessibility.

Industrial environments are particularly susceptible to gas leaks due to the presence of various chemicals and processes. According to the Occupational Safety and Health Administration (OSHA), in the United States alone, there are approximately 1000 incidents of industrial gas leaks reported annually, resulting in numerous injuries and fatalities. These incidents not only high risks to workers' safety but also have significant economic consequences, including property damage and production downtime[4].Therefore, the development of robust gas leakage detection systems is crucial for industrial safety and productivity.

Also, there is an example of the Bhopal gas tragedy. On the night of Dec 2-3, 1984, methyl isocyanate (MIC) leaked from a pesticide factory. Due to the gas leakage resulting in the death of thousands of people and causing injuries to hundreds of more. So, the Bhopal tragedy is the best example of the need for a gas leakage detection system.

In this project we have address this alarming trend and provide households and industries with a reliable solution for gas leakage detection and prevention. By implementing a system that integrates technologies such as the Node MCU ESP8266 microcontroller and MQ5 gas sensor, we aim to offer a cost-effective and efficient means of safeguarding lives and property[5].

Through timely alerts, visual and audible alarms, and real-time monitoring capabilities, our system empowers users to respond swiftly to gas leaks, minimizing the risk of harm. By promoting proactive safety measures, we strive to reduce the incidence of gas-related accidents and contribute to a safer environment for all[6].

IV. BLOCK DIAGRAM

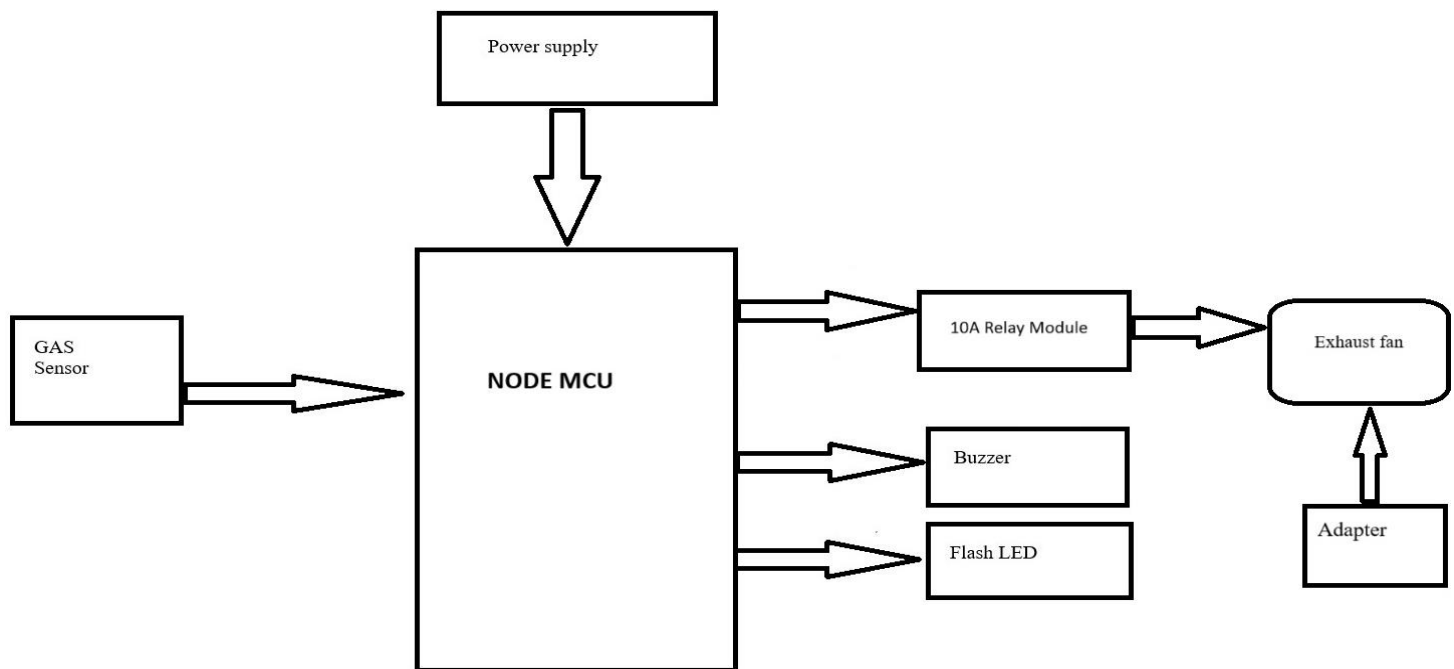

FIG.1 detection mechanism

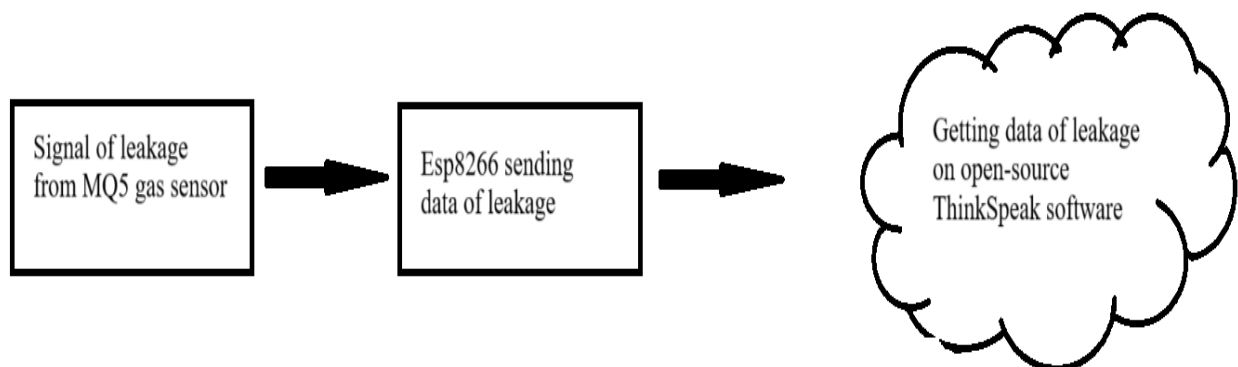
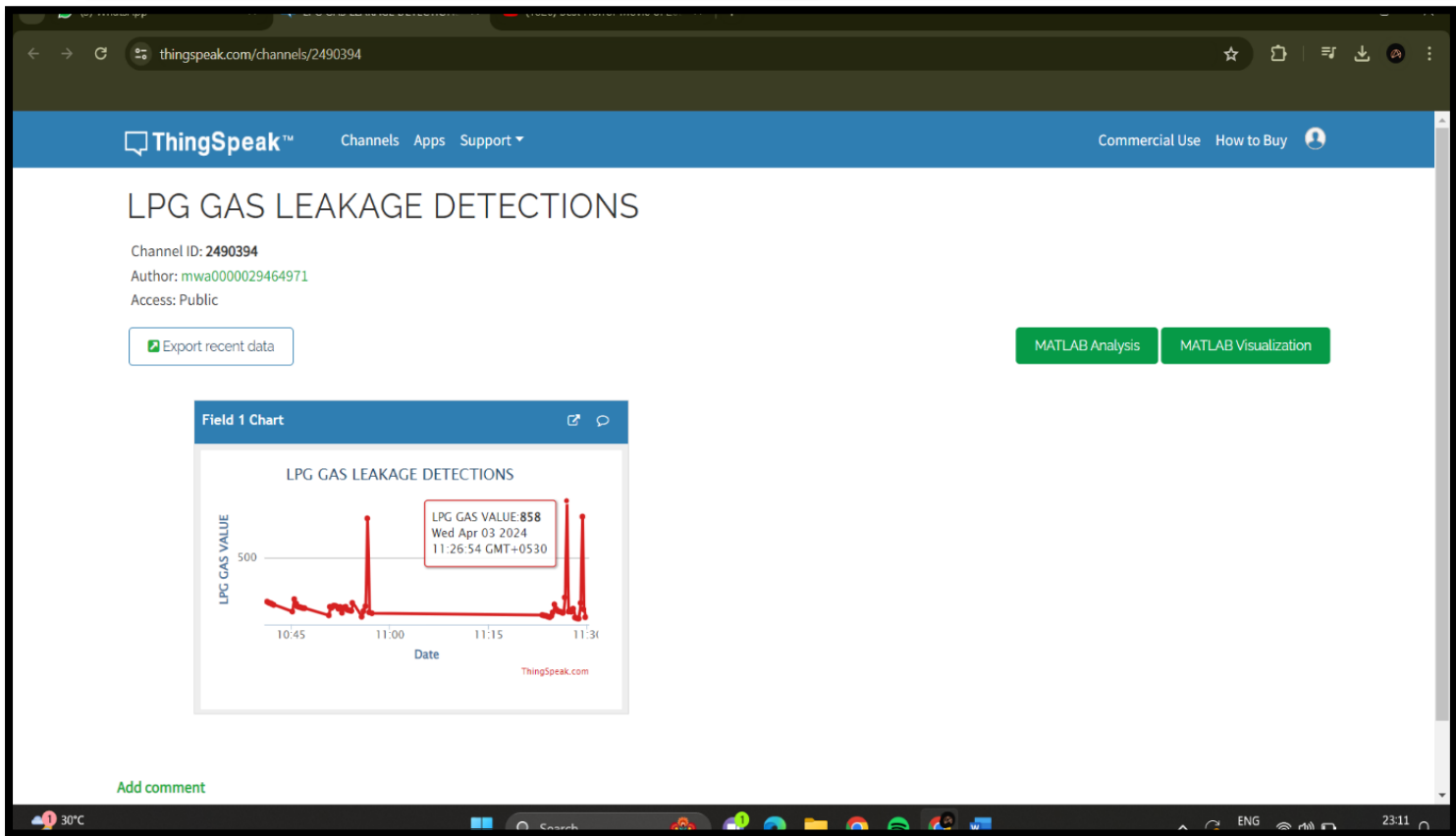

FIG. 2: Showing flow of data from hardware to software

V. ALGORITHM

- STEP 1. Initialization
- STEP 2. Calibration
- STEP 3. Continuous Monitoring
- STEP 4. Threshold Detection
- STEP 5. Gas Detection
- STEP 6. Led and alarm activation
- STEP 7. Exhaust fan trigger
- STEP 8. Safety Measures
- STEP 9. Logging and Reporting
- STEP 10. Continuous Monitoring and recovery

VI. RESULTS



VII CONCLUSION

The primary goal of our project, “Gas Leakage Detection System”, is to represent a significant leap forward in addressing the pressing safety concerns associated with gas leaks. The project works in two parts: the first phase consists of detecting and making visual and audible alerts to people who are physically available there, and the second phase is the real-time monitoring of leaks on open-source software from anywhere in the world.

Moving forward in our project, further research and development efforts can focus on enhancing the system’s capabilities, scalability, and integration with other smart technologies for comprehensive safety solutions. Through continued innovation and collaboration, we can strive towards creating safer environments for individuals, families, and communities worldwide

REFERENCES

- [1] Cause Analysis of the Large-Scale LPG Explosion Accident Based on Key Investigation Technology: A Case Study Xinming Qian, Ruoheng Zhang, Qi Zhang, Mengqi Yuan, and Yao Zhao *ACS Omega* **2021** 6 (31), 20644-20656 DOI: 10.1021/acsomega.1c02837
- [2] Risk Assessment of Liquefied Petroleum Gas Explosion in a Limited Space He Liang, Tao Wang, Zhenmin Luo, Xuqing Wang, Xiaofeng Kang, and Jun Deng *ACS Omega* **2021** 6 (38), 24683-24692 DOI:10.1021/acsomega.1c03430
- [3] “Design and Implementation of Kitchen Monitoring System by Using Wireless Sensor Network”, *International Journal of Applied Sciences, Engineering and Management* 02, March 2016, pp. 14 – 18 Kothamasu Ramanjaneyulu 1, B. Sekhar *International Journal of Applied Sciences, Engineering*
- [4] Putri AC, Insani IB, Hasibuan L, Faried A, Mose JC. Characteristics Of Liquefied Petroleum Gas (Lpg) Related Burn Injuries In Hasan Sadikin Bandung General Hospital. *Ann Burns Fire Disasters*. 2021 Dec 31;34(4):323-327. PMID: 35035326; PMCID: PMC8717903.
- [5] P. Manohar Assistant Professor of EEE Department, SRIT-ATP, G. Rohitha student of EEE Department SRIT-ATP.” LPG Gas Leakage Detection using Arduino” ISSN (Online): 2320- 9364, ISSN (Print): 2320-9356 www.ijres.org Volume 11 Issue 3 || March 2023.
- [6] Menon, P. C., Bipin, P. R., & Rao, P. V. (2021). IoT-Enabled Toxic Gas Detection and Alarming System Using Wireless Sensor Network with TAGDS Smart Algorithm. In *Cognitive Informatics and Soft Computing: Proceeding of CISC 2020* (pp. 31-41). Springer Singapore.