



AUTOMATIC TYRE PRESSURE INFLATION SYSTEM

Prof. Sunil Parge¹, Prof. Husain Shaikh², Abhishek Mishra³, Sourabh Kute⁴

¹Asst. Professor Mechanical Engineering Vidya Prasarini Sabha's College of Engineering and Technology, Lonavala

²Asst. Professor Mechanical Engineering Vidya Prasarini Sabha's College of Engineering and Technology, Lonavala

³Student Mechanical Engineering Vidya Prasarini Sabha's College of Engineering and Technology, Lonavala

⁴Student Mechanical Engineering Vidya Prasarini Sabha's College of Engineering and Technology, Lonavala

Abstract –

Project is concerned about and to develop an “automatic tyre pressure inflation system”. As we are aware that by drop of few pressure units in vehicle its results in the reduction in mileage, tyre life, safety and performance. This system can be placed in every in automobile under any operating condition, this will not only maintain the correct tyre pressure but also increase tyre life, mileage and safety so we have fabricated this system to inflate and deflate the tyre automatically by using control units. This system is named automatic because it checks the tyre pressure continuously using built control device and accordingly gives alert signals to the driver about the tyre condition.

Key Words: Vehicle Performance, Vehicle Efficiency, Vehicle Safety, Pressure switch, Solenoid Valve.

I.INTRODUCTION

According to a study, approximately 80% of the vehicles on the road are driven with one and more tyre under inflated. Tyre loses air during normal driving (especially after hitting pot holes or curbs) and seasonal changes in temperature



Fig 1.1: Tyres Wear

The vehicle can also lose one or two psi each month in winter and even more in the summer and you can't feel if they are properly inflated just by looking at them [2].

This is a system which is installed on the vehicle that enables the operator to adjust the inflation pressure of individual tyre of the vehicle.

This system has three general goals:

TO DETECT: -If the air pressure in tyre has dropped (Continuously check the air pressure in each tyre).

TO NOTIFY: -If there is any dropped in the air pressure in any tyre.

TO INFLATE\DEFLATER -In case of over pressure or under pressure the tyre pressure is maintained inflate the tyre to the required level if there is a drop in the tyre pressure and there has to be an air supply as well as check wall that opens only when needed.

1.1 PROBLEM DEFINITION

As we are aware that maintenance of correct tyre pressure is extremely important for the enhancement of tyre life. Due to drop in the pressure the tyre goes underinflated and reduces fuel economy, quickest tyre wear, not proper rolling, discomfort ride etc.

So to solve out all these problems we make an automatic tyre inflation system, which will properly inflate the tyre all the times.

2. LITERATURE REVIEW

Over a period of 12 weeks in 2013 a trial was conducted involving two cement tankers in NSW, Australia. For the first 6 weeks this system was turned on in both tankers and for another 6 weeks this system was turned off and graphs are prepared which shows that trucks with this system was in good condition like average vehicle idle time, average vehicle time spent using power take off, Avg. Emission and fuel combustion.

We also carried out a survey of different people and asked them when they inspect their tyre pressure, the report is as follows:-

5.40%	-	6 Monthly
8.10 %	-	Bi-monthly
24.32%	-	Monthly
13.51 %	-	5-10 days
43.24 %	-	Weekly
5.40%	-	3-5 Days

SURVEY REPORT

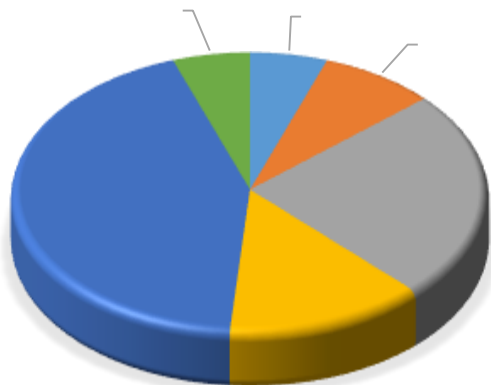

Pie Chart 2.1: Survey Report

The problems they were facing were tyre wear, time and efforts to check as well as fill the correct air pressure. Also, some unprofessional guys do not fill the correct pressure in the tyre which leads to over inflation or under inflation on the tyre. To overcome all these our system is the best suitable system also, in summer days, when

we drive, the temperature of the tyre increases rapidly, consequently, the heated air inside the tyres expands and its pressure rises quickly, which can lead to a tyre blowout with disastrous consequences. So, therefore, to maintain the correct tyre pressure in any weather condition, we must enable this system.

3. COMPONENT WITH SPECIFICATION

These are the components and specification used for the manufacture of the project

- a) Flexible air hose
- b) Wheel
- c) Quick release coupling
- d) Pressure switch
- e) Solenoid valve
- f) Power supply

A) Flexible air hose

It is kind of hollow tube which is used to transport air from the compressor to the tyre and it is flexible due to which it can easily transport.

B) Wheel

It is a circular component that is intended to rotate on an axle bearing.

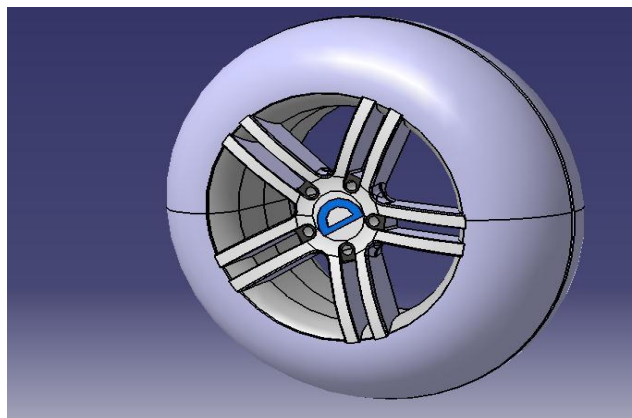

Fig 3.1: Wheel (CATIA)

C) Quick release coupling

A quick connect fitting, also called a quick disconnect or quick release coupling, is a coupling used to provide a fast, make-or-break connection of fluid transfer lines. Operated by hand, quick connect fittings replace threaded or flanged connections, which require wrenches. When equipped with self-sealing valves, quick connect fittings will, upon disconnection, automatically contain any fluid in the line.

D) Pressure switch

It is a device which is used to sense the pressure and transmit the signal (on/off) to the solenoid valve depending upon the current pressure. In this switch a piston is present with the calibrated spring. One end of the piston of the pressure is exerted which is the current pressure and the other end is connected to the switch. Whenever there is a change in the pressure the signal is transmitted. When the pressure of the tyre is dropped the switch transmit the signal to the solenoid valve and valve opens and start Inflated the tyre upto calibrated level when the pressure sense that it achieve the calibrated level switch give the signal and the solenoid valve will stop inflating the tyre.

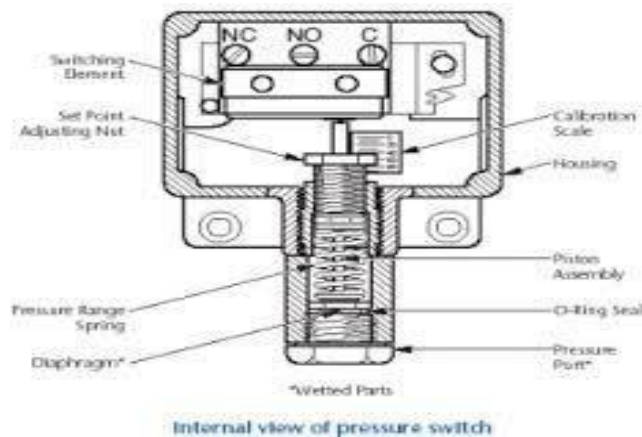
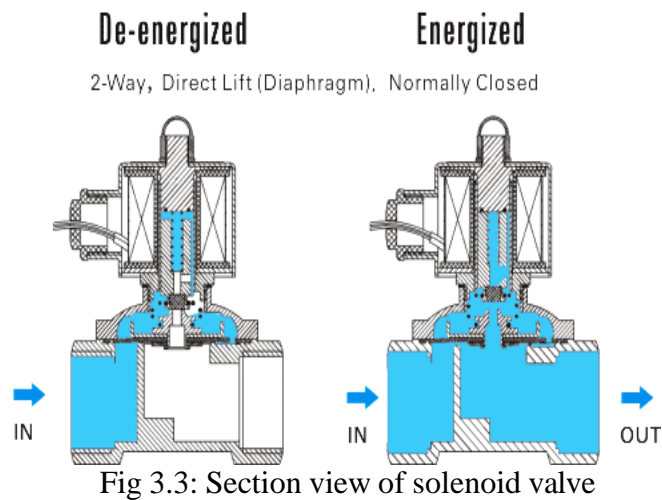

Fig 3.2: Internal view of pressure switch

E) Solenoid valve

It is an electromechanical controlled device which is used to allow or restricted the flow of air to pass through them from the compressor. It is attached between the compressor and the Flexible air hose. The coil\solenoid casing which is hollow and has a metallic finish in outer, in the hollow part the coil winding is present, which is energized and de- energized by the lead wire. The plunger is present at the centre of the casing with the calibrated spring, which is above the plunger.



Solenoid valve got the signal from the pressure switch through the lead wires and it electrically energized the electric coil which is positioned around the plunger and magnetic field is created which pulls the plunger up towards the centre of the coil. This opens the valve and air start flowing and it again got the signal from the pressure switch. It de-energized the electric coil and magnetic field ruined and plunger goes down and closes the valve, or stop flowing.

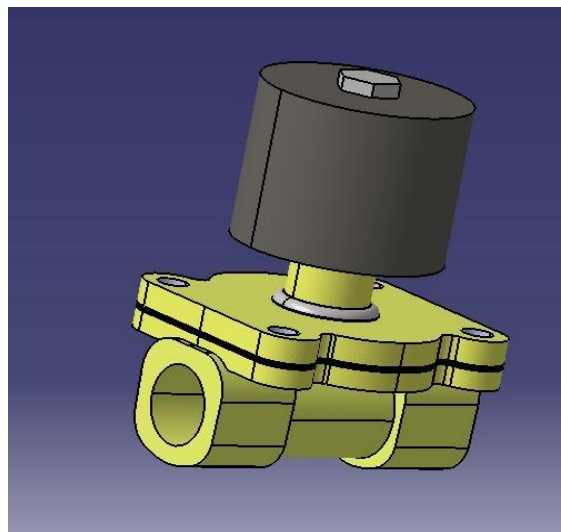

Fig 3.4: Solenoid valve (CATIA)

F) Power supply

In power supply, power means energy (electrical) and supply means transportation. It is a device which supplies the electric power to an electrical load. Its main function is to convert the electrical current from source to required current, voltage and frequency to the load.

3.1 CONSTRUCTION AND WORKING PRINCIPLE

In this one end of the Solenoid valve is attached to the compressor and another to the air hose. This hose is connected to the wheel and the switch, solenoid valve and switch also connected with each other to transmit the signals. The wheel and the components are assembled to the frame.

1. Flexible air hose
2. Wheel
3. Quick release coupling
4. Pressure switch
5. Solenoid valve
6. Power supply
7. Frame stand

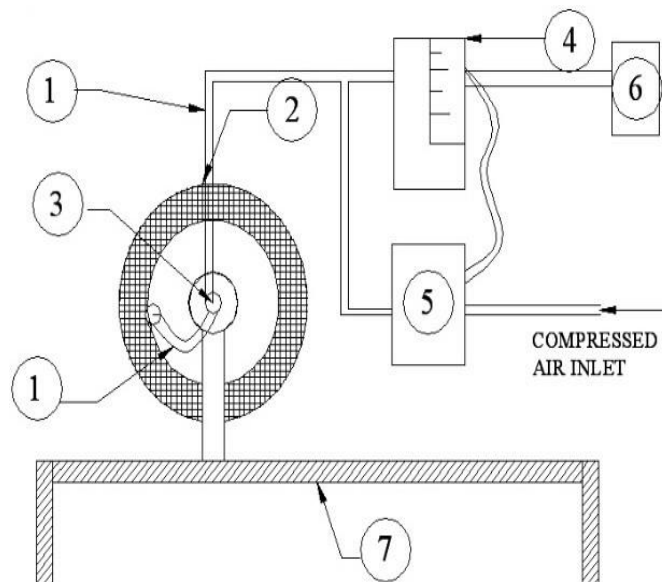

Fig 3.1.1: Construction of Project

Whenever there is a pressure drop in the tyre this pressure is a sense of the pressure sensor which is pre-calibrated, this switch gives the signal to the valve and the solenoid will energize and valve open. The compressed air will start flowing and inflating the tyre and when the calibrated pressure is obtained the sensor will give the signal and the solenoid will de-energized and valve close. With this we obtained the calibrated pressure and vehicle will run smoothly.

3.2 Advantages

There are many important positive points of this system as explained below;

1. The main advantage is that you don't require to check tyre pressure daily, it saves the time of air filling.
2. This will reduce the tyre wear because of uniform pressure in the tyres.
3. The cost of the system is optimized, but increases safety, comfort and efficiency. [5]
4. The weight of the system is very less so one can use in cars, buses etc. [5]
5. With this you don't have to stop in that area, which is not safe for you, when a tyre gets punctured.

CONCLUSIONS

We can conclude that this system ensures us that each and every tyre is properly inflated to the proper tyre pressure throughout the journey and it also improves tyre life, reduces tyre wear, increases fuel efficiency and also increases the overall safety of the vehicle, it also monitors the tyre pressure constantly, provide us the proper inflation and deflation of the tyre, and helps in providing a comfortable ride with better mileage

REFERENCES

- [1] A.V. Wadmare, P.S. Pandure "automatic tyre pressure controlling and self-inflation system: a review" IOSR-JMCE, e-ISSN: 2278-1684, p-ISSN: 2320-334x.
- [2] Indrajeet Burase, Suyash Kamble, Amol Patil, Avinash kharat "A survey on design and fabrication of automatic tyre inflation and deflation system. IJARIE-ISSN (O) -2395-4396, Vol-2 issue-3, 2016
- [3] Yuvraj Sahare, Rohit Gawande, Mayur Chore, Shubham Umathe, Dipak Tighare, Shubham Deshmukh, Akshay bharadbhunje "Introduction to design and fabrication of automatic tyre inflation and the hydraulic jack system" IJIFR, ISSN: 2347- 1697. Volume 4, Issue 7, March 2017.
- [4] Shreyansh Kumar Purwar "Automatic tire inflation system", IRJET e-ISSN: 2395-0056. P-ISSN: 2395-0072, Volume 04, Issue 04, Apr-2017.
- [5] M. Prakash, R. Anbalagan, M. Dinesh, G. Kameshwaram, B. G. Kesavan "Automatic tyre pressure inflation system for automobile "IJARBEST.

- [6] Case Study “Automatic tyre inflation management” Green truck partnership.
- [7] Tawanda Mushiri, Allan T. Muzhanje, Charles Mbohwa”Design of an automatic tyre pressure inflation system for small vehicles” International conference on industrial engineering and operations managements Detroit, Michigan, USA, September 23-25,2016