



# DESIGN AND MODIFICATION OF CAM OPERATED SPRING VALVE SYSTEM IN IC ENGINE

**Prof. Tanuja Hulavale<sup>1</sup>, Dr. Harish Harsurkar<sup>2</sup>, Omkar Thorve<sup>3</sup>, Palan Keval<sup>4</sup>**

<sup>1</sup>Asst. Professor Mechanical Engineering Vidya Prasarini Sabha's College of Engineering and Technology, Lonavala

<sup>2</sup>HOD Mechanical Engineering Vidya Prasarini Sabha's College of Engineering and Technology, Lonavala

<sup>3</sup>Student Mechanical Engineering Vidya Prasarini Sabha's College of Engineering and Technology, Lonavala

<sup>4</sup>Student Mechanical Engineering Vidya Prasarini Sabha's College of Engineering and Technology, Lonavala

## ABSTRACT

This paper stands for spring less valve system for IC Engine valve. Conventional valve system uses one valve for opening of cam and closing of cam totally depends upon spring, but spring less valve system uses two cams for its operation. In this work we are going to design spring less valve system. Model analysis of opening and closing cam of spring less valve system is done. For different material we have done harmonic analysis to know about failure of closing and opening cam. Harmonic analysis represents when resonance will occur. This new system improves the performance of IC Engine. This new system uses less power for its working.

**Keywords:** Spring less valve, Closing cam, Opening cam, Modal analysis, Harmonic analysis

## 1. INTRODUCTION

In IC Engine two types of valves are used for its operation. In conventional valve system opening of valve is done by cam and follower mechanism and closing of valve is done by restoring force of spring. When raised portion of cam comes in contact with follower of conventional valve system valve

opens. At the time of closing, spring connected to valve applies restoring force on valve to seal the cylinder. In case of spring less valve system we have used two cams and two followers for operation. We replaced the spring by using cam and follower mechanism. To follow the cam profile, follower should be tightly on cam profile. But as rpm of engine increases valve starts to open and close speedy, this cause valve float or cam jump, to avoid this we have to use spring having more stiffness to accomplish the requirement and this leads to loss of engine power to overcome this stiffness of spring. These disadvantages are surmount in spring less valve system which does not use springs for their function and there is nonappearance of cam jump occurrence, which results in enhanced engine operation and high power output from engine. In a conventional four stroke engine, valves are opened by a cam and closed by return spring. Spring less valve system has two cams and two followers, each of positive opening and closing without spring. To follow the path of cam profile follower should be tightly on cam profile.



**Figure 1.1:** valve float

**Valve Mechanism:** Intake and exhaust valves are shown below. Intake valves which is used in IC Engine is slightly bigger than exhaust valve because in case of intake, when engine starts sucking the charge some negative pressure will generate throughout suction stroke of engine. Therefore to avoid restriction to flow the charge, intake valve is kept little bigger in diameter. There is need of cooling at exhaust valve because at exhaust valve diameter of exhaust valve is little smaller so exhaust gases which is at higher temperature will pass through smaller area which creates problem to engine but in case of intake valve there is no need of cooling

because of intake valve air which is coming having relatively less temperature and also diameter is little bigger.

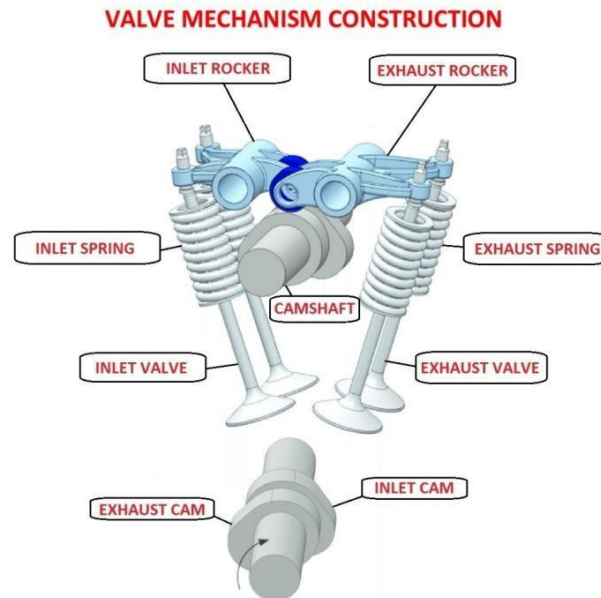

**Figure 1.2.** Valve mechanism

Operate the valve at right times, cam and follower mechanism is used as shown in above figure. As shown in fig cam has lobe shape at one of its side. This cam is present on cam shaft. Cam shaft and crank shaft is connected by chain or sprocket or gear mechanism. Valve is fully closed when follower is on base circle. As follower moves towards tip of the lobe valve opens and after reaching at tip of the valve again starts closing. This cycle repeats and valve is opened at required time and at required lift.

#### **Problem Statement:**

When we increase rpm of conventional valve system, cam jump may happen at higher rpm. Due to cam jump valve starts to float and damage happen to engine. Opening of valve is done by cam and closing of valve is done by spring. At higher rpm this spring may deflect and float of valve may happen. If this phenomenon happens, piston and valves will collide on each other and engine will be damaged. In multi cylinder engine if any one of the valve will fail, whole engine will have to change. Valve float of IC Engine can be reduced to some extent by increasing stiffness of spring but manufacturing of this spring is very risky job. Strict inspection is required to avoid any defect in spring and also it increases cost of the system. Lot of heat is generated in IC Engine which will transfer to the parts engine. Valves directly come in contact with combustion. For driving the cam shaft power is taken from crank shaft, as system uses stiff spring for its operation so there will be need of force to open the valve. If we want to design an engine for high rpm we need more force for its operation due to this power loss in engine itself. This causes decrease in engine output. According to application and stiffness, one or two or three springs are used. The engine which works on high speed needs higher stiffness so in that case concentric springs are used. At higher speed springs can be failed due to any defects present in springs. So we need extra care for it. Manufacturing processes are available to avoid defects and they need also strict inspection. So this is expensive.

**Objective:**

To enhance the efficiency of IC Engine by modification of the valve system of conventional IC Engine. Important objectives are as

- Replace spring by cam, for closing the valve.
- To handle the valve float in IC Engine.

**2. LITERATURE REVIEW**

[1] By Kosuke Nagaya, Hiroyuki Kobayashi, Kazuya- Here author presented opening and closing of valve by using electric motor. Planetary gears systems are used for valve timing. There are two gears in the pulley. Inner gear is used for connection of pulley. Disc centre, centre of planetary gear and cam shaft are connected. Phase can be easily controlled between exhaust valve and inlet valve. Control method has been presented for valve phase and valve lift. They had also done experiment.

[2] By Yalla M Surya Chandra Rao, V.V. Ramakrishna , S. Mohan Krishna- Here author have designed poppet valve by CATIA tool for vehical and also done analysis for different material. Structural and thermal analysis has to be done for poppet valve. In structure analysis authors intense on deformations, thermal stress and strains. From the outcome authors observed that least deformation and strains are in C/SiC poppet valve, but slightest strains are recorded in carbon-carbon composite.

[3] By Zibania, R. Marumob, J. Chumac and I. Ngebanid. For the modern car, the sparking and fueling is totally controlled by the engine control unit. Through the valve actions are mainly proscribed mechanically by the camshaft which is in spin driven by a crank shaft, via timing belt or chain. The software disciplined stepping valve, SCSV has exhibited its feasibility by using simulations and modelling. It also has a speedy valve event carrying out for all engine speeds, foremost to efficient, environmentally welcoming system. The SCSV notion can easily be migrated to multi piston engines as in cars. A starter less engine improves drivability and comfort. With the nonattendance of valve train, the engine loading is considerably reduced, resulting in enhanced efficiency.

[4] By—Manjunath Gowda M.R1, Harish Kumar R2, N.S.Venktesh Guptha3- With a forced, or pressurized, intake charge like that provided by a turbocharger, an engine can burn more fuel. Mostly Fuel utilization is based on Economy, Running costs, and Driving. Valves activate the breathing of engine. The timing of inhalation, that is, the timing of air intake and exhaust, is proscribed by the shape and phase angle of cams. To optimize the inhalation, engine requires different valve timing at dissimilar speed. When the rev increases, the period of intake and exhaust stroke decreases so that clean air becomes not fast sufficient to come into the combustion chamber. The exhaust becomes not speedy enough to leave the combustion chamber. Therefore, the best solution for opening the inlet valve is early stage and closing at the end.

[5] By Authors, Awanish Kumar Singh1, P Karthick- Here author said poppet valve is one of the most important components of engine which can exchange the fluid in the engine. Author designed poppet valve and also done analysis for different material. 3D model had done on CATIA and analysis had done on ANSYS tool. Here author had done structural and had also done thermal analysis. For analysis

25Mpa pressure is used. All the analysis is done for inlet valve and for exhaust valve. Author found Carbon/Sic is the best material for inlet and for exhaust SUH 1 STEEL is best.

### 3.METHODOLOGY

Step 1:- We decided to make new system which can operate the valve without using spring and overcome the problem of conventional valve system

Step 2:- After that we created CAD modal of all components using CATIA V5 R21tool.

Step 3:-After making CAD model of all components we assembled them and imported CAD model of closing and opening cam of system to ANSYS software.

Step 4:- Model Analysis is done using ANSYS WORKBENCH tool.

Step 5:- Results and conclusion is drawn from frequency response curve.

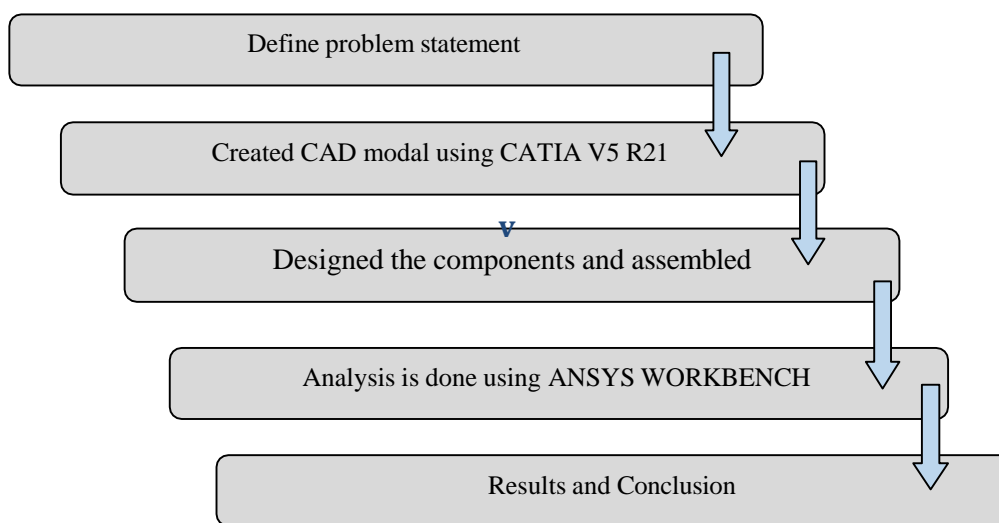

#### 3.1 SystemDesign

Design of spring less valve system is built on CATIA software. CATIA is a solid modeling tool that unites the 3D parametric features with 2D tools and also addresses each design-to-manufacturing method. Here we can also draw isometric view and drafting. It is also likely to generate model dimensions and generate reference dimensions in the drawing views. A little of the vital workbenches and their brief functionality description is given below:

**Part Design:** The most important workbench wanted for solid modeling. Here we can make sketch of all components which are going to be used in assembly.

**Generative Shape Design:** It allows us to make required shape by using appropriate tool. It provides us huge number of tool for different operations.

**Assembly:** The fundamentals of product structure, constraints, and moving assemblies and parts can be educated quickly. This is the workbench that allows involving all the parts to form a machine or a component.

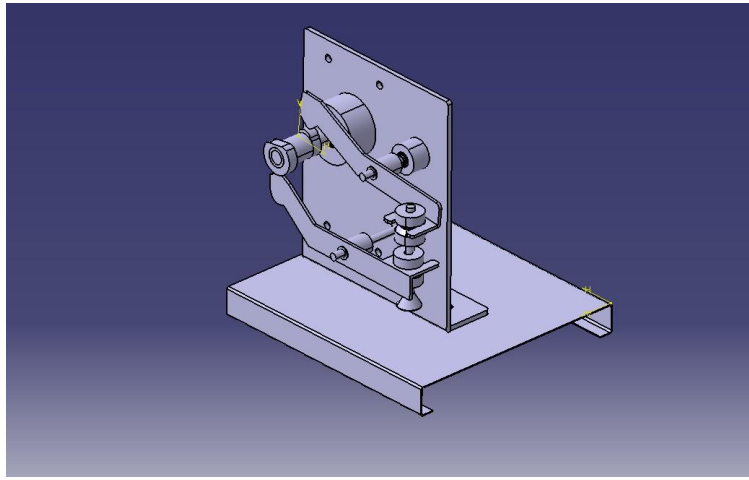

**Figure 3.1.1** System design

All components name of our design is

- 1) Base plate, 2) End plate, 3) Bearing holder 1, 4) Bearing holder 2, 5) Shaft 1, 6) Shaft 2, 6) Shaft 7) Openingcam, 8) Closing cam, 9) Opening rocker arm, 10) Closing rocker arm, 11) Bush 12) Bush 13) Valve holder,14) Valve

### **Working:**

Camshaft takes power from electric motor. In IC Engine this power is transmitted by motor through chain, belt or rope from crank shaft of engine to connecting cam shaft. In IC Engine cam is fixed to cam shaft so cam shaft and cam rotate with same speed. In the case of new system both cam i.e. opening cam and closing cam is fixed to cam shaft so both will rotate with same speed. Opening cam and closing cam are used to operate opening and closing rocker arm respectively to handle movement of valve. Opening rocker arm pushes opening cam so it will press on the valve and open it. At the same time closing cam does not restrict the movement of opening rocker and also it supports the valve and avoids free falling of valve. When valve lift from its seat then it starts to return to its seat i.e. it starts to close. This is done by closing rocker. This starts to lift the valve by follow the curved path of closing cam. At same time opening cam does not restrict the movement of closing cam. The new system eliminates the cam jump movement which reduces the risk of engine damage at high speed. In conventional valve spring mechanism, some power of engine is lost to overcome the spring force of valve, this loss is minimized in case of new system mechanism which results more shaft output.

- **Analysis**

In this project ANSYS WORKBENCH tool is used for analysis purpose. Workbench contains analysis of different type namely static, modal, harmonic, explicit dynamics, CFD, CFX etc. More and more engineers are using FEM to resolve daily problems of stress states, deformations, heat transfer, fluid flow, electromagnetism, along with others.. Here we are using model analysis for opening and closing cam. Following are steps in detail.

Geometry Descretization( meshing) Boundary condition Solve (solution) Interpretation of results

**Geometry and material details:** We can make geometry on ANSYS WORKBENCH but we made opening cam and closing cam on CATIA V5 R21 software and after that we import to ANSYS WORKBENCH. Here we are using structural steel material for opening cam and closing cam. The material detail and geometry for both opening cam and closing cam is given below as

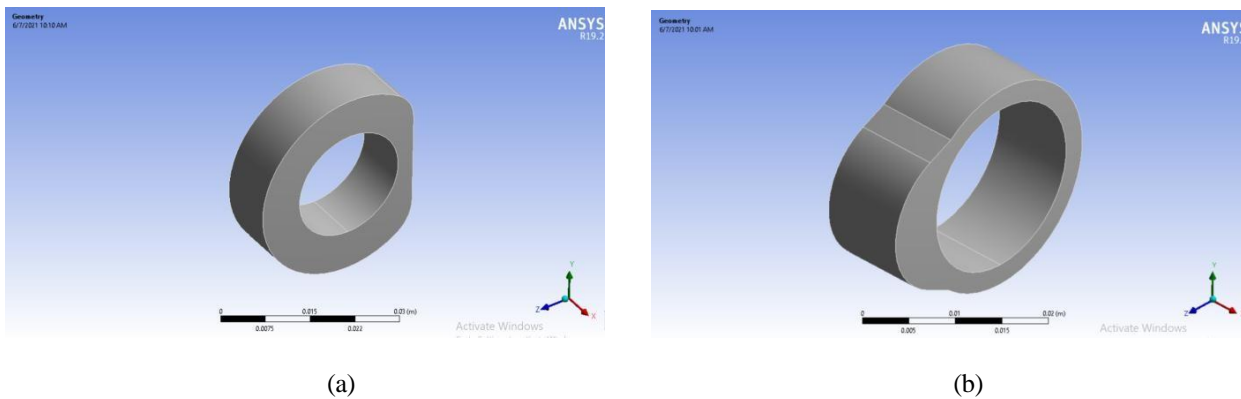

**Figure 3.2.1.** (a) Geometry of closing cam, (b) Geometry of opening cam

**Table 3.1.** Represents properties of the Stainless steel

Sr. No.	Property	Value	Units
1	Density	7750	Kg m <sup>-3</sup>
2	Tensile Yield Strength	2.07E+08	Pa
3	Compressive Yield Strength	2.07E+08	Pa
4	Tensile Ultimate strength	5.86E+08	Pa
5	Compressive Ultimate Strength	0	Pa
6	Isotropic Thermal Conductivity	15.1	Wm <sup>-1</sup> C <sup>-1</sup>
7	Isotropic Resistivity	7.7E-07	Ohm m

**Table 4.2.** Represents properties of the Structural steel

Sr. No.	Property	Value	Units
1	Density	7850	Kg m <sup>-3</sup>
2	Tensile Yield Strength	2.5+08	Pa
3	Compressive Yield Strength	2.5+08	Pa
4	Tensile Ultimate strength	4.6+08	Pa
5	Compressive Ultimate Strength	0	Pa
6	Isotropic Thermal Conductivity	60.5	Wm <sup>-1</sup> C <sup>-1</sup>
7	Isotropic Resistivity	1.7E-07	Ohm m

**Meshing:**

After importing CATIA design to ANSYS WORKBENCH and selecting material we have done fine meshing. Meshing is one of the important part of computer aided engineering (CAE) simulation process. The mesh influences the correctness, convergence and speed of the solution. Therefore, the improved and extra automated the meshing tools, the better the solution. Below figure is showing meshing of opening cam and closing cam

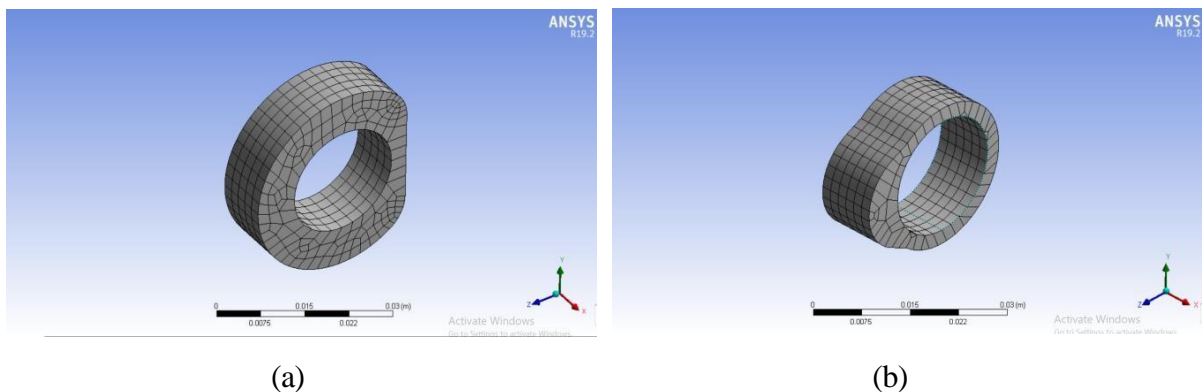
**Figure 4.2.2.** (a) Represent meshing of closing cam, (b) Represent meshing of opening cam**Boundary condition:**

Defining boundary conditions involves identifying the boundary locations and supplying information at the boundaries. The data requisite at a boundary depends upon the boundary condition type and the substantial models employed. Here we have used fixed support at inner portion of opening cam and closing cam because inner portion of opening cam and closing cam is rigidly connected to shaft.



Solution :

Analysis result is achieved after meshing and applying boundary conditions.

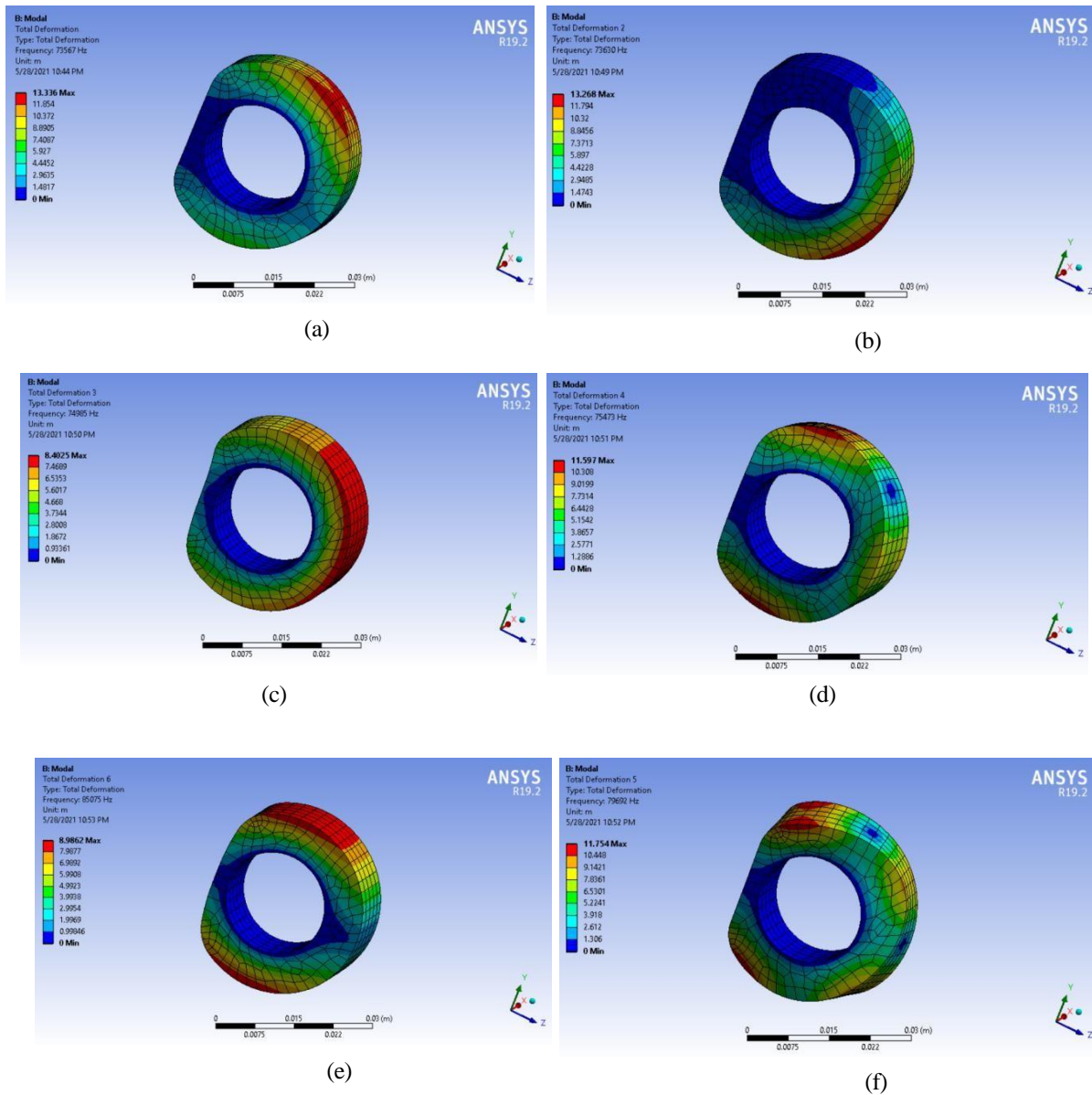
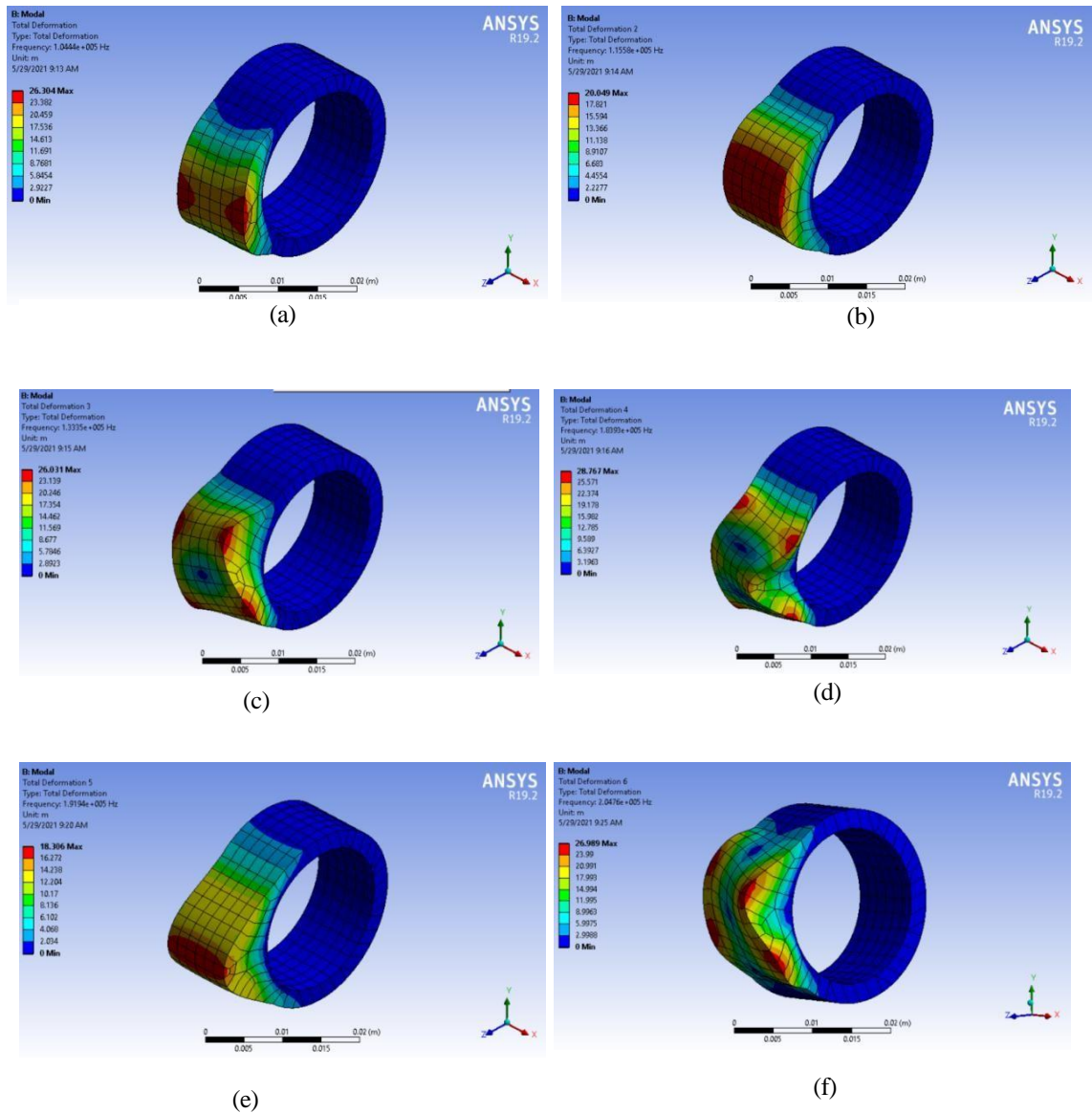

Figure 4.2.3. (a) Represents mode shape 1 at 73567Hz (b) mode shape 2 at 73630Hz (c) mode shape 3 at 74985Hz (d) mode shape 4 at 75473Hz (e) mode shape 5 at 85075Hz (f) mode shape 6 at 79692Hz



**Figure 4.2.4.** (a) Represents mode shape 1 at  $1.0444e^{+005}$ Hz (b) mode shape 2 at  $1.1558e^{+005}$ Hz (c) mode shape 3 at  $1.3335e^{+005}$ Hz (d) mode shape 4 at  $1.8393e^{+005}$ Hz (e) mode shape 5 at  $1.9194e^{+005}$ Hz (f) mode shape 6 at  $1.0476e^{+005}$ Hz

Above analysis represents mode shape at different frequencies for various loads. (Example;- bending, torsion, bending with torsion etc.)

### 4.RESULTS AND DISCUSSION

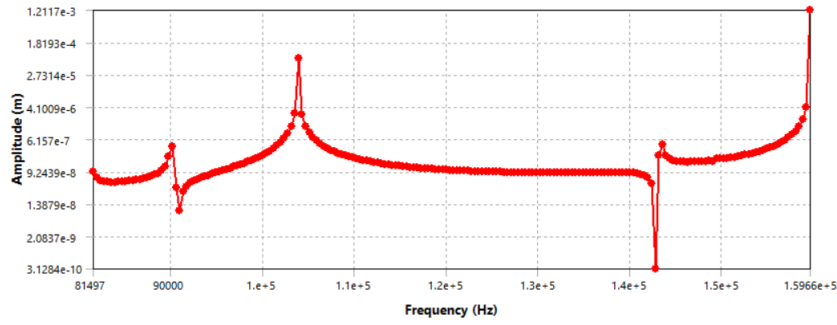

**Figure 4.1.** Frequency response curve of opening cam for Stainless Steel

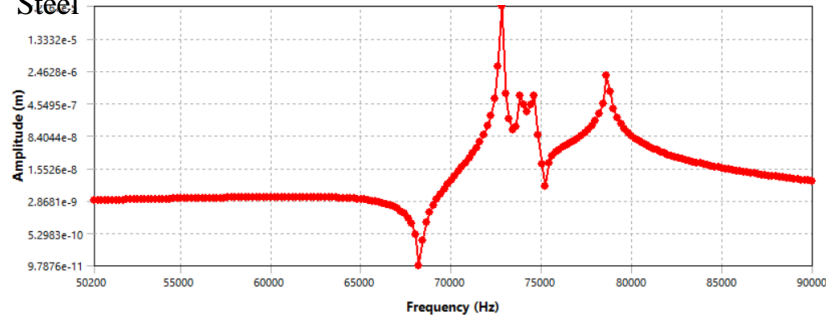

**Figure 4.2.** Frequency response curve of closing cam for stainless steel

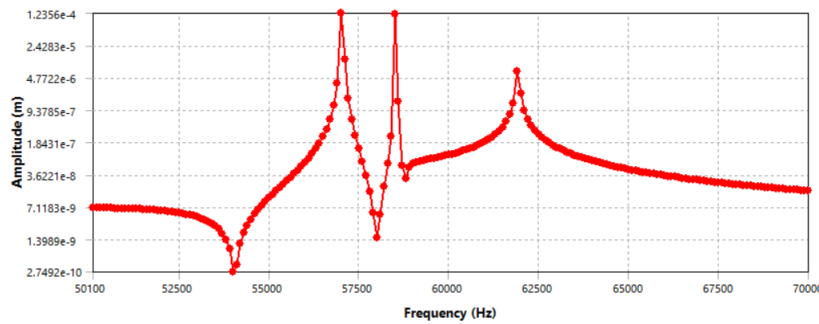

**Figure 4.3** Frequency response curve of closing cam for Gray Cast Iron

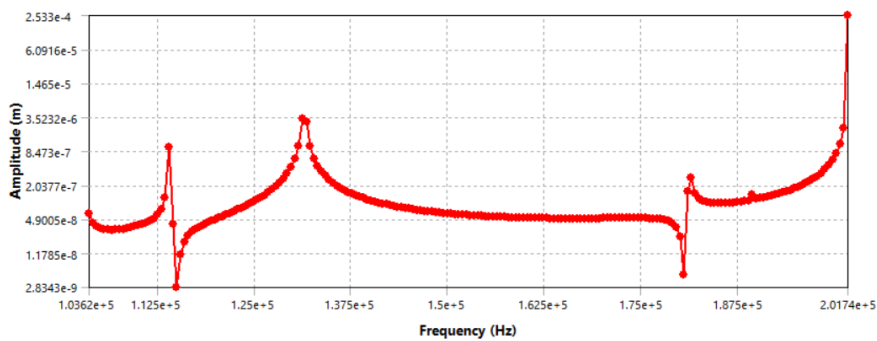

**Figure 4.4.** Frequency response curve of opening cam for Structural Steel

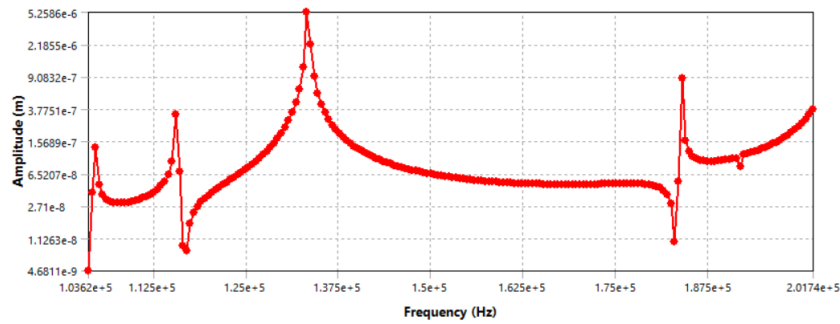

**Figure 4.5** Frequency response curve of opening cam for Gray Cast Iron

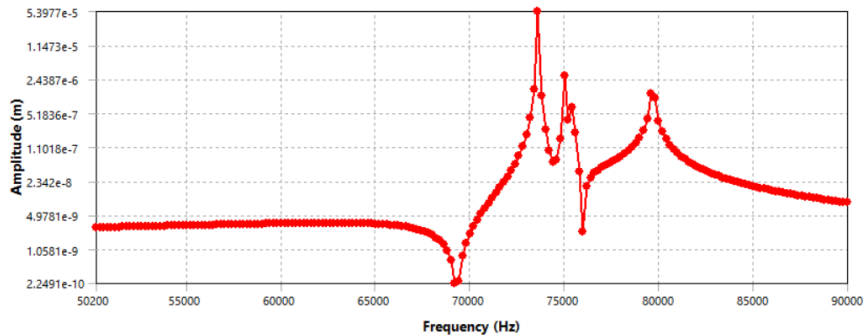

**Figure 4.6..** Frequency response curve of closing cam for structural steel

**Table 4.3.** Represents resonance frequency of closing cam and opening cam

Material Name	Resonance frequency of closing cam	Resonance frequency of opening cam
Gray cast iron	55625	$1.3491e^{+5}$
Stainless steel	72520	$1.5966e^{+5}$
Structural steel	73618	$2.0174e^{+5}$

Above graph is amplitude VS frequency. This graph represents frequency response curve for different materials. From this graph we can know when component or system will fail due to vibration. Figure 5.1 is showing closing cam will fail at 55625Hz and Figure 5.2 is showing opening cam will fail at  $1.3491e^{+5}$ Hz. So from graph we can say that for Grey Cast Iron, Closing and opening cam should design below 55625Hz because it's minimum in both frequencies. Similarly for stainless steel and structural steel we can say that closing and opening cam should design at 72520Hz and 73618Hz respectively. Overall from graph or table we can say that closing cam and opening cam should design at 73618Hz because it's minimum in both frequencies of structural steel and maximum in all designable frequencies.

## 5. CONCLUSION

Spring less valve system is designed by using CATIA V5 R-21 software. Harmonic analysis has been used to know the failure of closing cam and opening cam. We have done analysis of cam and follower by using Grey Cast Iron, Structural Steel, and Stainless Steel material on ANSYS WORKBENCH tool. Frequency response curve is showing structural steel is the best the material among these three materials. Cam and follower will fail at very high frequency so it is suitable for high speed vehicle. We are using these cam and follower in new system. These new system are able to control the movement of the system without any difficulties. This mechanism also helps to improve engine output.

## REFERENCE

- [1] Yalla M Surya Chandra Rao, V.V. Ramakrishna, S. Mohan Krishna, Structural and thermal analysis of poppet valve made of different materials, 2015
- [2] Awanish Kumar Singh<sup>1</sup>, P Karthick<sup>2</sup>, Design and analysis of poppet using composite materials, vol 4 , ISSN 2348-9480, 2017
- [3] <sup>1</sup>Vidyadhar. C. Kale, <sup>2</sup>Sagar.S.Deshpande “Design and Analysis of Poppet Valve for Enhanced Mechanical Properties with varied Geometric Parameters and Materials”; International Journal of Engineering Science and Technology, Kale, November,2014
- [4] Manjunath Gowda M.R<sup>1</sup> , Harish Kumar R<sup>2</sup> , N.S.Venktesh Guptha<sup>3</sup>, “Kinematic design and simulation of a flexibal valve lift mechanism for an IC Engine, VTU-RRC, Bengaam, Karnataka, 2015
- [5] Zibania, R. Marumob, J. Chumac, I. Ngebanid, Software controlled stepping valve system for modern car engine, GCSM 3-5 October 2016, Stellenbosch, South Aferica.
- [6] Kosuke Nagaya, Hiroyuki Kobayashi, Kazuya Koike, Valve timing and valve lift control mechanism for engines, Gunma University, Kiryu, Gunma 376-8517, Japan,2006
- [7] Rahul Watane, Sourabh Sancheti, Swapnil Sundecha, Nikhil Jagtap, Study of design and manufacturing of cam operated spring less valve system for IC engine, vol 6, p-ISSN: 2395-0072, 2019
- [8] S. M. Muzakkir\*, M. G. Patil, Harish Hirani, Design of Innovative Engine Valve: Background and Need , ISSN : 2277-1581, 2015
- [9] S. Jagannath Reddy, G.Praveen Kumar, Bollu Shravya, Camless Engine Using Electromagnetic Valve Actuator, IJPERA, 2018
- [10] Akshay Chaudhari<sup>1</sup>, Rahul Choudhari<sup>2</sup>, Mahesh Gite<sup>3</sup>, Design and Developement of a System to Operate ICEngine Valves Electromechanically, ISSN: 2350-0255; Volume 1, October, 2014

- [11] J. Tsai, C. R. Koch, and M. Saif, —Cycle Adaptive Feed Forward Approach Control of an Electromagnetic Valve Actuator, in Proc. 47th IEEE Conf. Decision Control, Cancun, Mexico, 2008, pp. 5698–5703.
- [12] L. Mianzo and H. Peng, —Output Feedback H preview Control of an Electromechanical Valve Actuator, IEEE Trans. Control Syst. Technol., vol. 15, no. 3, pp. 428–437, Apr. 2007.