



# INTELLIGENT DISCIPLINE MONITORING ROBOT

Mr.A.Kathiresan , S.Jei Keshav , A.John Robin, V.Gowtham

HoD, Student, Student , Student

INFORMATION TECHNOLOGY

PSG POLYTECHNIC COLLEGE, COIMBATORE, INDIA

*Abstract:* Intelligent disciplined learning environment is paramount to students' academic success and personal development. The emergence of the Internet of Things (IoT) technology offers unprecedented opportunities to enhance discipline monitoring within schools. Our introduces the concept of an "Intelligent Discipline Monitoring Robot" that leverages IoT capabilities to revolutionize discipline management in educational settings. The primary objective of our is to develop a robotic system that utilizes advanced technologies, including robotics, computer vision, and artificial intelligence, to enhance discipline monitoring within schools. The Intelligent Discipline Monitoring Robot aims to complement the efforts of educators and staff by providing an efficient and objective means of observing and addressing discipline-related incidents. The "Intelligent Discipline Monitoring Robot" represents a step toward harnessing technology to support positive learning environments. By deploying robotic assistance in discipline monitoring, we aim to create a safer and more conducive space for students' personal growth and academic success.

## I. INTRODUCTION

Traditional methods of discipline monitoring, often reliant on manual observation, can be limited in terms of coverage, accuracy, and timely intervention. With the rapid advancement of technology, the integration of the Internet of Things (IoT) into educational settings offers innovative solutions to address these challenges. This introduces the concept of an "Intelligent Discipline Monitoring Robot using IoT," aimed at revolutionizing discipline management in schools through the strategic amalgamation of robotics and IoT technologies. The primary objective of this is to develop a sophisticated robot that leverages the power of IoT sensors, data analytics, and automation to enhance discipline monitoring within schools. The Intelligent Discipline Monitoring Robot (IDMR) will serve as an autonomous and intelligent tool to complement the efforts of educators and administrators in fostering a safe and focused learning environment. The motivation behind this is rooted in the increasing demand for innovative solutions that can streamline discipline management while respecting students' privacy and dignity. Traditional methods of discipline monitoring often struggle to provide real-time insights, leading to delayed interventions and suboptimal outcomes. By integrating IoT sensors, the aims to collect and analyze relevant data instantaneously, enabling timely interventions and promoting a more proactive approach to discipline management. Intelligent control is an active field of research that brings artificial intelligence and automatic control together to solve class room control problems.

## 1.1 OVERVIEW AND ISSUES SOLVED

The Intelligent Discipline Monitoring Robot (IDMR) is a sophisticated robotic system designed to autonomously monitor discipline within schools.

It leverages IoT sensors, data analytics, and automation to collect and analyze relevant data in real-time.

The IDMR operates independently, complementing the efforts of educators and administrators in creating a safe and conducive learning environment.

**a. Limited Coverage and Accuracy:** Traditional methods of discipline monitoring relying on manual observation may have limitations in terms of coverage and accuracy. The IDMR addresses this by utilizing a network of IoT sensors strategically placed throughout the school premises to monitor various activities and incidents.

**b. Delayed Interventions:** Without real-time insights, interventions in disciplinary incidents may be delayed, leading to suboptimal outcomes. The IDMR aims to provide instant data analysis, enabling educators and administrators to intervene promptly and effectively.

**c. Privacy and Dignity Concerns:** Maintaining students' privacy and dignity while monitoring discipline is crucial. The IDMR ensures data collection and analysis are conducted in a manner that respects students' privacy rights, mitigating concerns associated with traditional surveillance methods.

**d. Proactive Approach:** Reactive approaches to discipline management may not always be effective. By leveraging IoT sensors and AI, the IDMR enables a proactive approach to discipline management, anticipating potential issues and taking preventive measures.

**e. Efficiency and Objectivity:** Manual discipline monitoring processes can be time-consuming and subjective. The IDMR automates data collection and analysis, enhancing efficiency, and providing objective insights into disciplinary incidents.

**f. Safety:** Creating a safe learning environment is paramount. The IDMR contributes to safety by promptly detecting and addressing disciplinary issues, thereby preventing escalations and fostering a secure atmosphere for students' personal growth and academic success.

## 1.2 PROBLEM DEFINITION

**Problem:** Traditional methods of discipline monitoring in educational settings are often limited in coverage, accuracy, timeliness, and objectivity. Manual observation by educators and staff may not provide real-time insights into disciplinary incidents, leading to delayed interventions and potentially compromising the safety and conducive learning environment within schools. Additionally, subjective judgments and privacy concerns associated with surveillance methods may further impede effective discipline management.

**Objective:** Develop a sophisticated robotic system leveraging IoT capabilities to revolutionize discipline monitoring within schools. The system should autonomously collect, analyze, and respond to discipline-related incidents in real-time, complementing the efforts of educators and administrators. Key objectives include:

**Enhancing coverage and accuracy:** Ensure comprehensive monitoring of school premises and activities through the strategic deployment of IoT sensors and robotic capabilities.

**Enabling timely interventions:** Provide instant data analysis to facilitate prompt responses to disciplinary incidents, minimizing disruptions to the learning environment and ensuring the safety of students and staff.

**Respecting privacy and dignity:** Implement data collection and analysis protocols that prioritize students' privacy rights and dignity, mitigating concerns associated with traditional surveillance methods.

**Promoting a proactive approach:** Anticipate potential disciplinary issues through advanced data analytics and AI, enabling proactive measures to prevent escalations and foster a positive learning environment.

**Improving efficiency and objectivity:** Automate discipline monitoring processes to enhance efficiency and objectivity, reducing the burden on educators and staff while providing objective insights into disciplinary incidents.

**Scope:** The development of the Intelligent Discipline Monitoring Robot using IoT encompasses the design, implementation, and testing of a robotic system equipped with IoT sensors, AI algorithms, and automation capabilities. The system should be adaptable to various educational settings and capable of integrating with existing infrastructure and protocols.

### 1.3 PROPOSED SYSTEM

#### How it Works:

**Sensors:** The robot has special sensors to detect things like noise, movement, and environmental conditions (like temperature).

**Alerts:** When it senses something unusual, like loud noise or too much movement, it sends an alert to teachers or staff.

**Moves Around:** The robot can move around the school on its own, checking different areas like classrooms, hallways, and playgrounds.

**Shows Data:** It has a screen that shows information about what it's sensing, so teachers and staff can see what's going on.

#### Benefits:

**Quick Response:** It helps teachers respond quickly to any problems, like loud disturbances or unsafe behavior.

**Keeps Things Fair:** Because it's based on sensors, it's objective and doesn't play favorites.

**Safe Environment:** By catching problems early, it helps create a safer and more comfortable environment for students to learn.

#### Simple Components:

**Sensors:** These are like the robot's eyes and ears, helping it "see" and "hear" what's happening around it.

**Alert System:** This sends messages to teachers and staff when something needs attention.

**Movement Mechanism:** Allows the robot to move around the school independently.

**Display Screen:** Shows information about what the robot is sensing.

#### How it Fits in Schools:

**Deployment:** The robot can be placed in different areas of the school where monitoring is needed most.

**Easy to Use:** Teachers and staff can easily understand and use the information provided by the robot.

**Privacy-Friendly:** It respects students' privacy by only collecting data related to behavior, not personal information.

**Advantages:**

**Peace of Mind:** Teachers can focus more on teaching, knowing the robot is helping keep things under control.

**Fairness:** It treats everyone the same, without any biases.

**Improved Safety:** By detecting problems early, it helps prevent accidents and conflicts.

This simpler explanation breaks down the proposed system into its key components and benefits, making it easier to understand how the "Intelligent Discipline Monitoring Robot using IoT" works and why it's beneficial for schools.

## II. LITERATURE SURVEY

The burgeoning field of Intelligent Discipline Monitoring Robots (IDMR) presents a promising solution to address the complexities associated with maintaining discipline in educational settings. This technological innovation has attracted significant interest and research, particularly due to its potential to transform how discipline is monitored and maintained within schools. The literature surrounding IDMRs is extensive and covers a range of topics from their technological intricacies and functionalities to their potential impact on educational environments. This comprehensive literature survey aims to deeply explore these crucial areas to develop a nuanced understanding of this evolving field.

Intelligent Discipline Monitoring Robots have garnered attention as a viable approach to the challenges associated with monitoring student behavior and maintaining discipline in educational settings. These robots are designed to assist educators by providing an automated and unbiased system for observing and addressing discipline-related incidents. Within the literature, discussions primarily focus on the technological features, capabilities, and the possible consequences for the educational landscape.

To conclude, the literature on Intelligent Discipline Monitoring Robots represents a dynamic and diverse field covering various aspects such as technology, capabilities, and their potential impact on educational settings. As technological advancements continue to evolve, these robots are envisioned to reshape the management of discipline in schools, making it more efficient, effective, and impartial. However, their integration also brings challenges that must be addressed for their widespread adoption. Future research will likely continue to explore and push the boundaries of this intriguing field, ultimately shaping the future of discipline management in educational settings.

### Challenges in Educational Discipline Management:

The maintenance of discipline in educational settings is often the most challenging and crucial aspect of creating an optimal learning environment. Research in this domain highlights the difficulties faced by traditional methods, including the reliance on manual observation, which can be biased and inconsistent. Issues such as inadequate coverage, delayed interventions, and the inability to monitor all areas effectively are common. Intelligent Discipline Monitoring Robots are viewed as a potential solution that could help overcome some of these challenges efficiently.

### Indian Educational Context:

In the context of Indian education, maintaining discipline involves unique challenges due to diverse and densely populated classrooms, as well as cultural variations across regions. The term "Little Indian" here could refer to localized or scaled-down operations of these robots tailored to specific needs of Indian schools. Literature in this area explores how IDMRs can be adapted to meet the

particular requirements of the Indian educational market, considering factors such as varied educational norms, classroom sizes, and resource availability.

### 3.1 Methodology

Research focused on Intelligent Discipline Monitoring Robots (IDMR) and their deployment in educational settings adopts diverse methodologies to thoroughly investigate this innovative technology. Primarily, empirical studies are conducted to assess the practicality and effectiveness of these robots in various educational environments. These studies typically include pilot programs and experiments where IDMRs are implemented in classrooms and school corridors to evaluate their performance, reliability, and adaptability to different learning atmospheres. Additionally, surveys and interviews with relevant stakeholders, such as teachers, school administrators, parents, and students, are employed to gather their views, concerns, and expectations regarding the implementation of discipline monitoring robots.

Furthermore, a quantitative approach is often used to collect and analyze data on aspects like effectiveness in incident reporting, behavior modification impacts, and resource allocation efficiency. Researchers also apply data mining and machine learning techniques to parse through large datasets, deriving insights about optimizing robot patrols, improving intervention accuracy, and reducing operational costs. Simultaneously, qualitative methods such as case studies and ethnographic research help understand the social and cultural impacts of IDMRs, shedding light on issues related to acceptance, trust, and ethical considerations within school environments.

A multidisciplinary approach is also common, involving experts from the fields of robotics, computer science, education, psychology, and policy analysis. This collaborative methodology is crucial in providing a comprehensive evaluation of the technology's potential, challenges, and opportunities in educational settings, ensuring a balanced view that can guide future developments and policy decisions.

**Technical Advancement:** Research often focuses on the engineering and design of IDMRs, including aspects such as navigation, pattern recognition, and sensor integration.

**Operational Efficacy:** Studies frequently assess the effectiveness and efficiency of IDMRs compared to traditional disciplinary approaches, examining factors such as response time, coverage, and the ability to maintain continuous monitoring.

**User Experience and Acceptance:** The acceptance of IDMRs among school stakeholders is a critical factor in their successful implementation. Research explores attitudes, preferences, and barriers to adoption among students, educators, and parents.

**Regulatory and Ethical Considerations:** The deployment of IDMRs involves examining ethical and regulatory issues. Researchers analyze how existing educational policies and ethical norms apply to these technologies and suggest necessary adjustments.

**Impact on Educational Environment:** Literature often discusses the potential impact of IDMRs on the educational setting, including their role in enhancing the learning environment, reducing disruptions, and supporting teachers.

**Privacy and Security Implications:** A significant focus within the research is the privacy and security concerns associated with the deployment of IDMRs, emphasizing the importance of safeguarding student data and ensuring compliant usage.



## 3.2 Technologies and Tools

In the domain of maintaining discipline in educational environments, the emergence of Intelligent Discipline Monitoring Robots represents a significant advancement. These innovative systems, often referred to as "Little Disciplinarians," are equipped with cutting-edge technologies and functionalities that are revolutionizing the discipline monitoring landscape within schools. This section explores the various technologies and tools driving these Intelligent Discipline Monitoring Robots, elucidating their pivotal role in shaping the future of discipline management in educational settings.

### 3.2.1 Computer Vision and Sensing Technologies

At the core of Intelligent Discipline Monitoring Robots lies computer vision technology. These robots are equipped with cameras, LiDAR sensors, ultrasonic sensors, and various advanced sensors to perceive and navigate their surroundings accurately. Computer vision allows these robots to identify obstacles, students, and other elements in their environment, ensuring effective monitoring within school premises.

The incorporation of machine learning algorithms further enhances the capabilities of these robots. By continuously analyzing data and encountering different scenarios, they improve their ability to interpret and respond to disciplinary incidents. This iterative learning process strengthens their reliability and adaptability, making them more effective in maintaining discipline in educational settings.

## SYSTEM ANALYSIS

At the core of this chapter lies the recognition that the success of the entire initiative heavily relies on a thorough understanding of the multifaceted requirements essential to the Intelligent Discipline Monitoring Robot system. This understanding spans both functional and nonfunctional requirements, each playing a crucial role in the cohesive functionality and efficacy of the system.

A primary focus of this detailed analysis is on software requirements. These requirements encompass a wide range, from algorithms governing decision-making processes to programs orchestrating the operation of the monitoring robots. Foundational algorithms governing functions like behavior recognition, movement control, and incident reporting are essential for the seamless operation of the robots. The adaptability and reliability of these algorithms significantly impact the effectiveness of the entire discipline monitoring process.

Furthermore, the analysis extends to data storage and processing capabilities, critical for facilitating communication between the monitoring robots, central control system, and school personnel. Real-time data collection, processing, and dissemination form the backbone of an efficient monitoring system. A robust software architecture is essential for coordinating these interactions effectively, ensuring smooth information flow and collaboration between different components.

The success of this innovative approach depends not only on technical considerations but also on environmental factors, regulatory compliance, and risk management strategies. The systematic analysis undertaken in this chapter serves as a foundation for the successful development and deployment of Intelligent Discipline Monitoring Robots.

The scope of the analysis goes beyond technical aspects, encompassing a holistic understanding of environmental nuances, legal requirements, and potential risks associated with deploying discipline monitoring robots in educational settings. Comprehensive insights are essential for developing a system that meets functional requirements while aligning with ethical, legal, and social considerations.

In essence, Chapter 4 lays the groundwork for the implementation of Intelligent Discipline Monitoring Robots within educational environments. It represents a convergence of technical expertise, strategic planning, and a comprehensive vision aimed at revolutionizing discipline monitoring practices.

The depth and breadth of this analysis not only pave the way for the successful deployment of discipline monitoring robots but also set a precedent for future advancements in educational technology. It establishes a framework for innovation and transformative solutions in discipline management, promising to redefine the educational landscape. Through meticulous scrutiny and understanding of various factors, this chapter sets the stage for the seamless integration of Intelligent Discipline Monitoring Robots, poised to enhance efficiency, reliability, and safety in educational settings.

## SYSTEM DESIGN

The overarching system design comprises a diverse array of components, each contributing significantly to the overall functionality and efficacy of these robots. It encompasses an intricate mesh of mechanical and electrical elements, intricately intertwined with the integration of advanced sensors, navigation systems, and sophisticated artificial intelligence algorithms. Furthermore, the design process meticulously takes into account the physical attributes and capabilities of the robots, considering factors such as size, load-carrying capacity, and mobility to optimize performance. Additionally, it pays meticulous attention to critical considerations such as safety features, energy efficiency, and the user interface, crucial components for controlling and monitoring these robots effectively. This chapter unravels a comprehensive understanding of the systematic approach and exhaustive planning required in designing and fabricating autonomous delivery robots tailored explicitly to meet the distinctive demands of the Little Indian Last Mile project, offering readers a detailed insight into this innovative technology's intricate development.

Creating a comprehensive overview incorporating detailed insights about each component of the autonomous delivery robot demands a substantial expansion of the information provided. Here's an expanded breakdown:

### 1.1. L298N:

The L298N is a dual H-bridge motor driver module that is commonly used in robotics and automation projects. It allows for the control of the speed and direction of DC motors. This module is particularly useful for applications where precise motor control is required, such as in robot movements, conveyor systems, or any project involving motor-driven mechanisms.

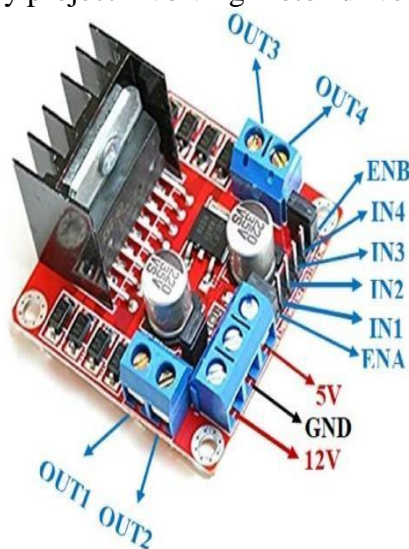

FIG.5.1 L298N

## 1.2. Node MCU:

Node MCU is an open-source firmware and development kit that is based on the ESP8266Wi-Fi module. It provides an easy and cost-effective way to connect microcontrollers to Wi-Fi networks, making it an essential component for IoT applications. Node MCU runs on the Lua script interpreter and offers a wide range of GPIO pins for digital and analog input/output. It is known for its compatibility with the Arduino IDE and ease of use in developing IoT projects.

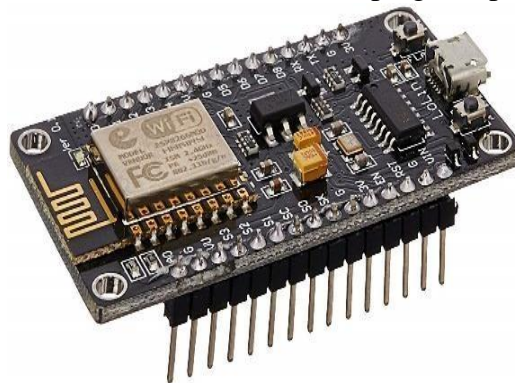

FIG.5.2 Node MCU

## 1.3. HC-05 Bluetooth:

The HC-05 Bluetooth module serves as a wireless communication hub, facilitating the establishment of Bluetooth connections for remote control and data exchange. Its integration empowers the robot with seamless connectivity to external devices and systems. This connectivity not only enhances the robot's operational versatility but also enables it to integrate into larger networks or systems, thereby enhancing its functionality. The ability to communicate wirelessly is pivotal for remote monitoring, control, and updates, making it a crucial component in ensuring the robot's adaptability and efficiency.

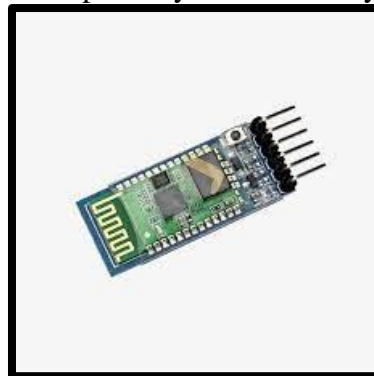

FIG.5.3  
HC-05 Bluetooth

## 1.4. Alarm:

An alarm is a signaling device or system that is used to alert individuals or notify them of a specific event or condition. In IoT applications, alarms can take various forms, including sound alarms (audible alerts), visual alarms (such as flashing lights or displays), or even notifications sent to mobile devices or computers. Alarms are crucial for indicating the occurrence of events, such as security breaches, environmental changes, or system malfunctions, ensuring that appropriate actions are taken in response.



FIG.1.4 Alarm



## 1.5 IR Sensor and IR Proximity:

Leveraging infrared radiation, the IR Sensor and IR Proximity sensors play a pivotal role in detecting obstacles and gauging proximity within the robot's environment. Their contribution to the robot's perception capabilities enables it to navigate autonomously by identifying and circumventing potential obstructions or hazards. These sensors act as the robot's 'eyes,' providing crucial information about its immediate surroundings. Their integration ensures the robot's ability to make informed decisions in real-time, enabling it to navigate safely through challenging environments or crowded spaces.

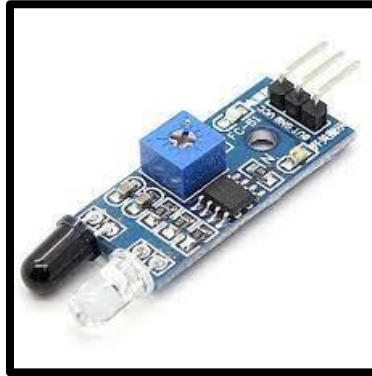

FIG 1.5 IR Sensor and IR Proximity

## 1.6 4 Wheel :

Configured with six wheels, each measuring 10 inches in diameter and 2 inches in width, these wheels offer stability, traction, and efficient maneuverability to the robot. Their design is specifically tailored to support the robot's weight and facilitate traversal across diverse terrains. These wheels provide the necessary grip and stability, ensuring reliable and adaptable mobility during delivery tasks. Their design is optimized to navigate various surfaces, making them indispensable for ensuring the robot's stability..and effectiveness, especially during the last-mile delivery process where navigating through different environments is crucial.



FIG.1.6 4 Wheel

## 1.7 Battery:

A battery is an electrochemical device that stores and provides electrical energy for powering electronic devices and IoT components. In IoT applications, batteries are often used to supply power to wireless sensors, transmitters, and other low-power devices that are not connected to a traditional power source. Battery-operated IoT devices offer the advantage of flexibility and portability but require periodic maintenance or replacement to ensure continued functionality. Battery life is a critical consideration in designing IoT systems to avoid frequent replacements or recharging.



FIG.1.7 Battery

### 1.8 Aluminum Sheet - Laser Cutting Technology - Bending Process - Drilling Work:

The utilization of aluminum sheets, shaped through precise laser cutting, bending processes, and meticulous drilling, facilitates the fabrication of durable and lightweight structural elements. These components form the framework or body of the robot, offering resilience and flexibility while accommodating multiple functionalities and integrated components. The aluminum sheet components provide the structural framework for the robot, offering durability and flexibility. Their lightweight yet sturdy nature ensures that the robot remains agile while withstanding various environmental conditions or operational stresses.



FIG.1.8 Aluminum Sheet - Laser Cutting Technology - Bending Process

### 1.9 Sound Sensor:

A sound sensor, often in the form of a small microphone or sound detector module, can capture sound waves and convert them into electrical signals. These sensors are sensitive to changes in sound intensity and are used in IoT projects for tasks like noise level monitoring, voice recognition, or sound-activated systems. They help process audio data and trigger actions based on sound input.

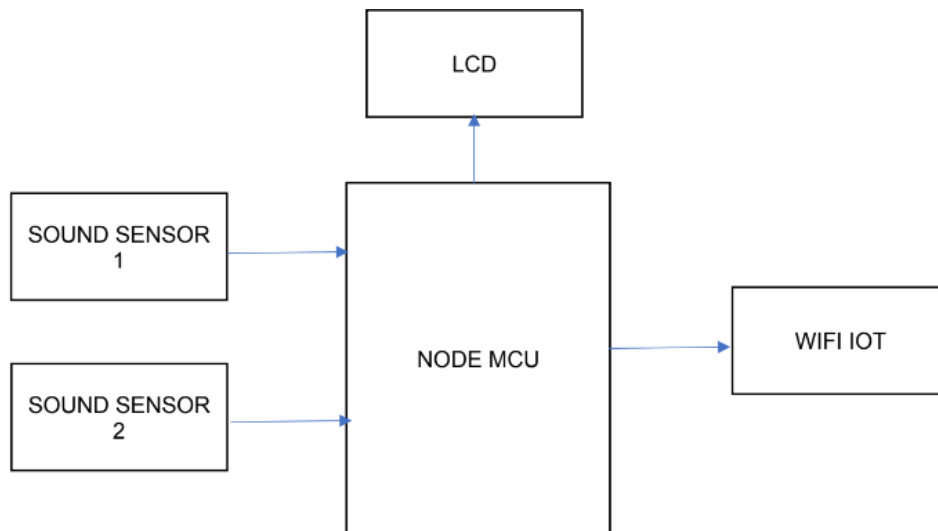
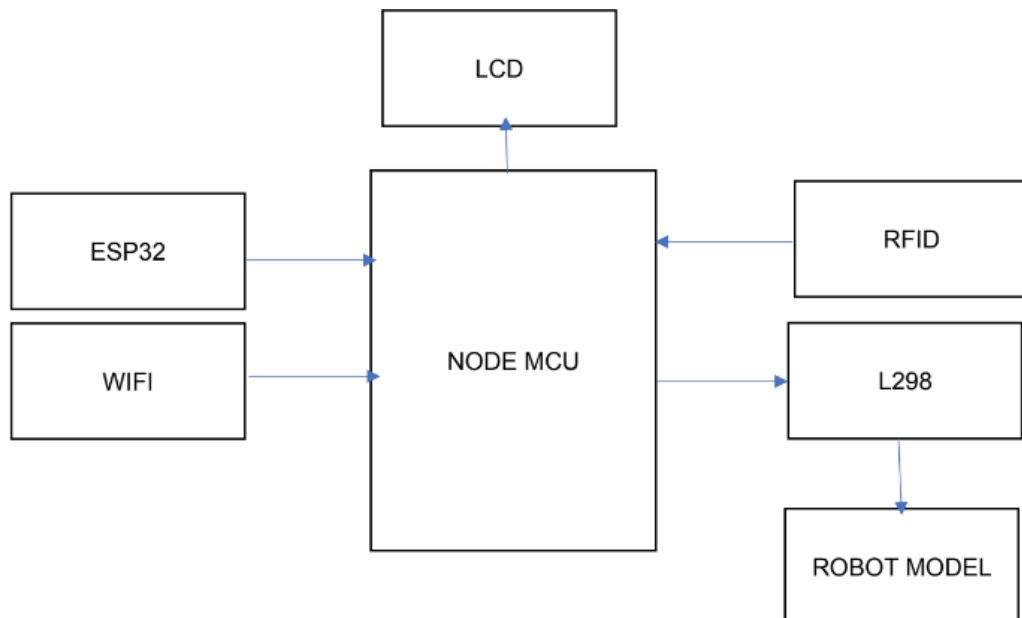

FIG 1.9 Sound Sensor

**BLOCK DIAGRAM****TRANSMITTER :****RECEIVER :****WORKING OPERATIONS**

The foundation of the Intelligent Discipline Monitoring Robot lies in its utilization of IoT sensors strategically integrated onto the robot's structure. These sensors, including motion detectors, audio sensors, and environmental sensors, are strategically positioned to capture real-time data from the robot's surroundings, specifically within designated areas of the school.

Motion detectors track movements and presence within the monitored areas, while audio sensors capture sound levels to detect anomalies such as loud disturbances or altercations. Environmental sensors monitor factors like temperature and humidity, ensuring the learning environment remains comfortable and conducive to student engagement.

These sensors work in tandem to collect data, which is then processed and analyzed within the robot's onboard systems. Leveraging IoT communication protocols, the robot communicates its findings and responses to a central control system or designated personnel. Alerts and notifications are promptly transmitted, enabling educators and administrators to access real-time data and insights remotely. This remote access empowers

them to respond swiftly to discipline-related incidents as they occur, facilitating proactive intervention and resolution.

The working principle of the "Intelligent Discipline Monitoring Robot using IoT" emphasizes the integration of IoT sensors, data analysis, and automation to create an intelligent and responsive monitoring system within educational settings. By harnessing the capabilities of IoT technology, the robot enhances discipline monitoring by providing educators and administrators with valuable insights into student behavior and environmental conditions. This innovative solution not only assists in maintaining discipline but also contributes to fostering a safer and more conducive learning environment for students, ultimately supporting their academic success and personal development.

## MODULES

The potential of Intelligent Discipline Monitoring Robots in managing school environments has sparked significant interest, showcasing their capability to transform the approach to maintaining discipline within educational settings, particularly in dynamic environments like schools. These robots can address the unique challenges presented in bustling educational environments, but their successful implementation requires the careful integration of various modules and components. This article will explore the essential modules needed for deploying Intelligent Discipline Monitoring Robots effectively in the active ecosystem of a school.

### 1.1.1 Sensing and Monitoring:

At the heart of Intelligent Discipline Monitoring Robots lies their sensing and monitoring system, which includes components such as motion detectors, audio sensors, and environmental sensors. These tools enable the robot to understand its surroundings, providing critical data for monitoring student behavior, detecting potential disciplinary issues, and identifying environmental factors that may affect learning. In the lively and varied spaces of a school, this module is crucial for maintaining a conducive educational environment.

### 1.1.2 Data Processing and Analysis:

The effectiveness of data processing and analysis is key in interpreting the vast amounts of data collected by the robot's sensors. Utilizing algorithms and machine learning, the robot can process this data to identify patterns or anomalies in student behavior and environmental conditions. This module is essential for providing actionable insights that can help educators address potential issues promptly.

### 1.1.3 Interaction and Communication:

Managing interactions between the robot and both students and staff is critical. This module includes capabilities such as speech recognition, natural language processing, and interactive displays that facilitate clear and effective communication. In a culturally diverse setting like a school, ensuring that interactions are positive and respectful is vital for the robot's acceptance and effectiveness..

### 1.1.4 Security and Privacy Measures:

Given the sensitive nature of monitoring in educational settings, robust security and privacy measures are paramount. This includes data encryption, secure data storage, and strict access controls to protect the privacy of students and staff while preventing unauthorized access to sensitive information.

### 1.1.5 Alert and Response Systems:

To act on the data collected and analyzed, the robot is equipped with an alert and response system that notifies school administrators and teachers of detected issues. This system ensures that appropriate actions can be taken swiftly to maintain discipline and support the educational process.

## 1.2 DATA FLOW DIAGRAM:

Integrating Intelligent Discipline Monitoring Robots into school environments offers a substantial opportunity to enhance discipline and create a supportive educational atmosphere. Incorporating key modules—sensing and monitoring, data processing and analysis, interaction and communication, security and privacy measures, and alert and response systems—ensures effective monitoring, respectful engagements, and secure operations.

**LEVEL 0:**

Creating a Data Flow Diagram (DFD) at Level 0 provides an overview that outlines the external entities, processes, data stores, and data flows relevant to the robot's operation within a school environment.

**LEVEL 1:**

At Level 1, the DFD expands into detailed processes, showing interactions between external entities, processes, data stores, and data flows. It examines essential processes such as sensor data input, behavior analysis, interaction management, and privacy controls.

**LEVEL 2:**

The Level 2 DFD provides an in-depth breakdown into sub-processes, offering detailed insights into monitoring mechanics, data analysis techniques, communication protocols, and security measures.

The successful implementation and rigorous testing of Intelligent Discipline Monitoring Robots within educational settings represent a critical phase in enhancing school safety and discipline. This chapter delves into the practical aspects of turning conceptual designs into operational, effective systems. The journey from idea to actual deployment includes a series of carefully planned steps that require detailed planning, precise execution, and comprehensive testing.

Central to this phase is the integration of hardware and software components. This includes assembling the robot chassis, installing a range of sensors (motion detectors, audio sensors, environmental sensors), integrating processing units, and developing control software. Thorough testing protocols are crucial to ensure the robot can navigate school environments effectively and interact appropriately with students and staff.

The implementation phase involves deploying these advanced robots in the complex, real-world environment of a school. Emphasizing strict safety measures is essential to minimize risks. Extensive testing in various conditions and scenarios is vital to refine the robot's performance and responsiveness. This includes assessing their capability to handle unexpected situations, adapt to different school activities, and maintain consistent performance. User experience is also a key focus, as the acceptance and effectiveness of the robot significantly impact its success in improving school discipline.

The successful deployment and testing of Intelligent Discipline Monitoring Robots mark a significant milestone in the trajectory of enhancing discipline and safety in educational settings. It represents the crucial shift from theoretical design to practical application, requiring meticulous attention to detail, adherence to safety protocols, and comprehensive evaluations to ensure the system's effectiveness and seamless operation in real-world conditions.

**Outlined segments within this chapter include:**

**1.1 Prototyping:** Before full-scale implementation, this section details the prototyping process involving successive design iterations, careful component selection, and refinement to optimize functionality and efficiency.

**1.2 Integration of Sensors:** Critical to the robot's functionality, this section explains how various sensors are integrated into the robot's design, enabling it to monitor student behavior and environmental conditions effectively.

**1.3 Software Development:** Beyond hardware, this phase includes developing the robot's software architecture, which involves algorithms for data analysis, communication protocols for alerting staff, and user interfaces for monitoring and control.

**1.4 Field Testing:** After assembling the robots and developing the software, extensive field testing is conducted within the school environment. This section explores the testing process across various real-world scenarios, emphasizing safety and comprehensive data collection.



**1.5 Performance Evaluation:** This section outlines the metrics and results from testing the robots' performance, including evaluations of detection accuracy, responsiveness, and safety to ensure they meet the required standards.

**1.6 Incorporation of User Feedback:** The system's iterative refinement is based on gathering and integrating feedback from students, teachers, and administrators. This section discusses methods for collecting this feedback and using it to enhance system functionality and user experience.

### **Key Algorithms Used by Intelligent Discipline Monitoring Robots:**

- 1. Behavior Analysis Algorithms:** To understand and predict student behavior patterns, these algorithms process data collected from sensors, identifying potential disciplinary issues.
  - 2. Anomaly Detection Algorithms:** These algorithms help in identifying deviations from normal behavior, crucial for preemptive actions to maintain discipline.
  - 3. Data Encryption and Security Protocols:** Ensuring the privacy and security of the data collected is essential, using advanced encryption methods and secure communication protocols to protect sensitive information.
  - 4. Behavior Analysis Algorithms:** These algorithms analyze data from sensors to recognize patterns in student behavior, allowing the robot to identify potential disciplinary issues and take appropriate actions.
  - 5. Anomaly Detection Algorithms:** Similar to behavior analysis, anomaly detection algorithms help the robot identify deviations from normal behavior, enabling timely interventions to maintain discipline.
  - 6. Machine Learning and Computer Vision:** Algorithms in machine learning and computer vision enable the robot to interpret its surroundings, recognizing actions and interactions among students and staff. This facilitates informed decisions for effective monitoring and intervention.
  - 7. Reinforcement Learning:** Through reinforcement learning, the robot can optimize its monitoring strategies based on feedback received over time. By rewarding successful interventions and penalizing ineffective ones, reinforcement learning helps improve the robot's disciplinary capabilities.
  - 8. Communication and Coordination Algorithms:** These algorithms enable the robot to communicate with designated personnel or central monitoring systems, facilitating efficient coordination in responding to discipline-related incidents.
- Energy Management Algorithms:** Given the need for continuous operation, energy management algorithms optimize the robot's battery usage. By considering factors like patrol routes and charging station locations, these algorithms ensure the robot can operate effectively throughout the school day.

### **CONCLUSION**

The "Intelligent Discipline Monitoring Robots: School Guardian" initiative represents a significant advancement in the realm of educational technology and discipline management. This transformative endeavor has reached several key milestones, offering valuable insights into the integration of robotics and IoT technology to enhance discipline monitoring within school environments. Notably, it demonstrates the feasibility and effectiveness of deploying intelligent robots to observe and address discipline-related incidents in real-time, fostering a safer and more conducive learning environment for students.

A cornerstone of this initiative lies in the utilization of robust sensor technology, artificial intelligence, and machine learning algorithms. These technological components empower the robots to adapt and respond effectively to various disciplinary situations, ensuring timely interventions and proactive management of student behavior. Despite encountering challenges along the way, including technical complexities and regulatory considerations, these obstacles have served as valuable learning experiences, driving continuous improvement in the system's design and functionality.

Looking forward, the "Intelligent Discipline Monitoring Robots: School Guardian" project holds promise for further expansion and scalability within educational institutions worldwide. As technology continues to evolve, the potential applications of intelligent monitoring robots extend beyond discipline management to encompass various aspects of school administration and student support services. With ongoing dedication and collaboration, the vision of integrating these robots seamlessly into school environments appears achievable, reshaping the landscape of discipline management and enhancing student well-being.

The impact of this project transcends its technical aspects, significantly influencing the social and educational fabric of school communities. By promoting a safer and more disciplined learning environment, the "School Guardian" robots contribute to fostering positive academic outcomes and personal development among students. Additionally, their implementation underscores a commitment to sustainability, as the efficient monitoring of student behavior reduces instances of disciplinary incidents and promotes a harmonious school environment.

In summary, the "Intelligent Discipline Monitoring Robots: School Guardian" initiative embodies innovation, continuous learning, and forward-thinking solutions in the field of education. It represents a significant step towards leveraging technology to support educators and administrators in their efforts to create a conducive learning environment conducive to student success and well-being.

## **FUTURE ENHANCEMENT**

In the context of the "Intelligent Discipline Monitoring Robot: School Guardian" project, envisioning future enhancements becomes crucial for advancing its effectiveness and capabilities. One significant area for improvement lies in augmenting the robot's sensing and perception capabilities. This enhancement entails integrating state-of-the-art sensors, such as advanced cameras and audio sensors, to enable the robot to accurately detect and interpret various aspects of the school environment. By enhancing its ability to perceive movements, sound levels, and environmental factors, the robot can better monitor student behavior and identify potential disciplinary incidents in real-time.

Additionally, future enhancements should focus on refining the robot's data processing and analysis capabilities. By leveraging advanced algorithms and machine learning techniques, the robot can analyze incoming data more efficiently and derive actionable insights to support educators and administrators in making informed decisions regarding discipline management. This includes identifying patterns in student behavior, predicting potential conflicts or disruptions, and recommending appropriate interventions or preventive measures.

Moreover, enhancing the robot's communication and interaction capabilities is essential for facilitating seamless collaboration between the robot, school staff, and students. Implementing natural language processing algorithms enables the robot to communicate effectively with individuals and respond to inquiries or directives in a clear and concise manner. This fosters positive interactions and enhances the overall user experience, promoting acceptance and trust in the robot's role within the school environment.

Furthermore, future enhancements should prioritize the development of adaptive and customizable features that cater to the unique needs and preferences of each school setting. This includes the ability to configure the robot's monitoring parameters, adjust its behavior based on specific disciplinary policies or guidelines, and tailor its communication style to align with the school's culture and values. By providing flexibility and customization options, the robot can better integrate into diverse educational settings and effectively support discipline management efforts.

Looking ahead, the integration of advanced technologies such as artificial intelligence and automation holds the potential to further enhance the capabilities of the "School Guardian" robot. By continuously innovating and incorporating feedback from educators, administrators, and students, the "School Guardian" can evolve into a highly sophisticated and indispensable tool for promoting a safe, supportive, and conducive learning environment in schools.

**PROJECT OUTPUTS:**

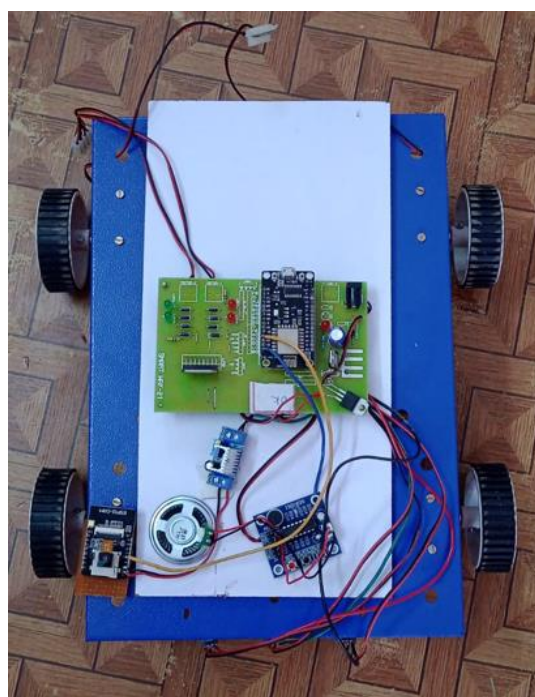
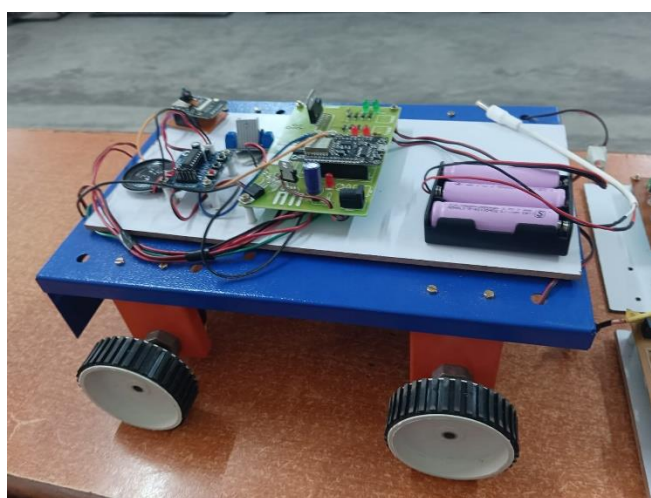
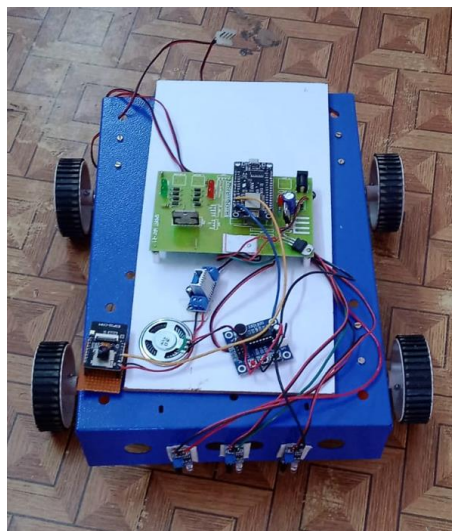

**REFERENCES**

1. Sensors, Actuators, and Algorithms. MIT Press.
2. Siciliano, B., Sciavicco, L., et al. (2009). Robotics: Modelling, Planning and Control Springer.
3. Murphy, K. P. (2012). Machine Learning: A Probabilistic Perspective. MIT Press.
4. Goodfellow, I., Bengio, Y., & Courville, A. (2016). Deep Learning. MIT Press.
5. Szeliski, R. (2010). Computer Vision: Algorithms and Applications. Springer.
6. Various Authors. (1978). Discipline in Schools: A Symposium. Taylor & Francis.
7. Blase, J., et al. (2011). Handbook of School Discipline. Routledge.
8. Alevan, V., et al. (Eds.). (2018). Artificial Intelligence in Education: 19th International Conference, AIED 2018, London, UK, June 27-30, 2018, Proceedings. Springer