



NONINVASIVE GLUCOSE MONITORING

¹Ms.G. Anitha Chowdary, ²R. Sharon Sarah, ³S. Vasudha, ⁴B. Praneeth Kumar, ⁵P. Srikanth

¹Assistant Professor, ^{2,3,4,5} Student

¹Dept of Electronics & Communication Engineering,

¹TKR College of Engineering and Technology, Hyderabad, India

Abstract: Diabetes is a common chronic disease in mostly all countries worldwide. The most commonly used method to measure glucose level in blood is an invasive method which is painful, expensive and danger in spreading infectious diseases. Over a long term, the invasive method results in damage of finger tissues. As an alternative, the Non-invasive method can be used which facilitates frequent testing, relieves pain and discomfort caused by frequent finger pricks. A Non-invasive method of glucose level measurement is proposed. The variation in the intensity of NIR light received from the photo detector after passing through the finger is used to determine the glucose level of blood. The measured glucose level is displayed in LCD display and also transmitted to the android application which is created in the mobile phone to display and store data via Bluetooth.

Index Terms - Component, formatting, style, styling, insert.

INTRODUCTION:

Measurement of glucose concentration in human blood is an essential requirement for the medical treatment of any person by a physician. The existing measurement techniques may be of three types namely, invasive, minimally invasive and non-invasive. In the conventional biochemical invasive technique, a certain volume of blood is drawn from the human body to determine the glucose content in the blood sample through biochemical analysis of the sample. This technique is very painful for a person. At present, a less painful minimally invasive portable glucometer technique is being used to measure blood glucose where only a drop of blood is used by pricking any finger with a pricking device.

The minimum invasive methods like micro dialysis probe method, fluorescent sensor method, glucowatch method etc. are also painful methods. So painless non-invasive techniques with good reliability and accuracy is the recent trends in blood glucose monitoring. These techniques may be of various types such as near-infrared (NIR) light spectroscopy type, mid-infrared (MIR) light spectroscopy type, far-infrared (FIR) spectroscopy type, Raman spectroscopy type, polarized light rotation type, impedance spectroscopy type etc. In this analysis, the glucose present in blood in organs like fingertip, finger web, cuticle, forearm, earlobe etc.

changes the spectrum of light passing through the organ and from the spectroscopic analysis of this light, the glucose content of the blood is estimated.

BLOCK DIAGRAM:

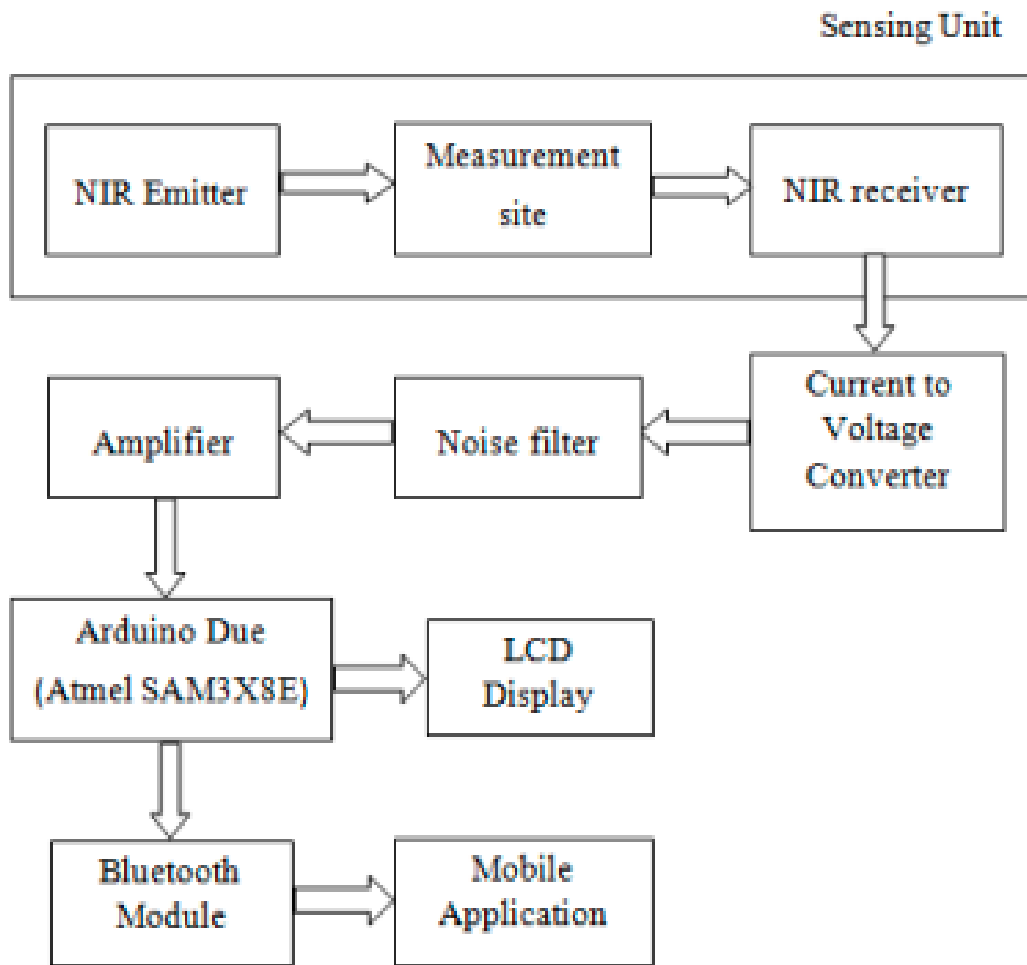

SCHEMATIC DIAGRAM:

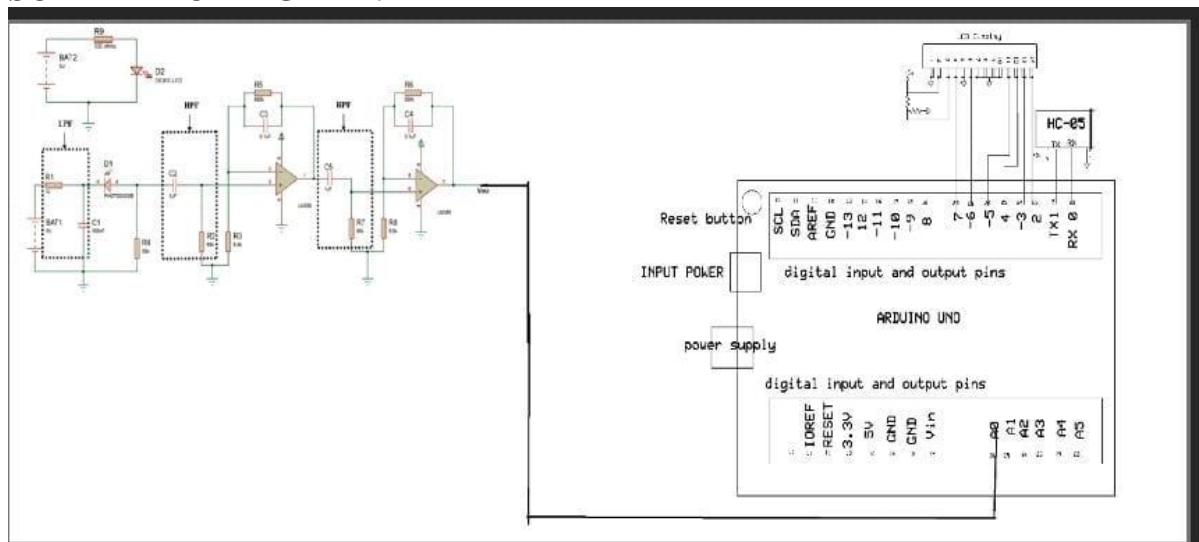

WORKING:

The above schematic diagram of non-invasive glucose measurement explains the interfacing section of each component with micro controller.

The circuit diagram of the designed system consists of filtering stage and amplification stage as shown in figure . The electrical current obtained from the photo detector is converted into the voltage by placing the load resistance $R_4 = 50k\Omega$ at the anode side of photodiode. The cut-off frequency of high pass filter and low pass filter are designed as 2.34 Hz and 1.59 kHz respectively.

The amplified output voltage is connected to analog pin A0 of Arduino due microcontroller for converting the analog signal into digital values. This digital value corresponds to the glucose level. From this digital value, the actual glucose level is determined using polynomial regression equation. This equation is formed from the glucose levels obtained from the laboratory using invasive measurement.

A mobile app is created for displaying and storing the predicted glucose value. Bluetooth module (HC-05) is connected at 0,1 pins of Arduino uno microcontroller in order to communicate with the mobile app via Bluetooth. Once the mobile app is connected to the microcontroller via Bluetooth, the glucose value will be displayed in the mobile app screen. As well as this system monitoring this data on LCD connected at 2 to 7 pins of Arduino respectively.

RESULT: The main of the project “noninvasive glucose measurement” was designed a noninvasive based blood glucose measurement system using Arduino and NIR. This system able to monitor the blood glucose levels into the app through Bluetooth.

**CONCLUSION:**

Integrating features of all the hardware components used have been developed in it. Presence of every module has been reasoned out and placed carefully, thus contributing to the best working of the unit. Secondly, using highly advanced IC's with the help of growing technology, the project has been successfully implemented. Thus, the project has been successfully designed and tested.

Invasive method of glucose measurement is painful, costly and discomfort. It also has a risk of infection and not used for continuous monitoring. In order to overcome the above disadvantages, a noninvasive method for blood glucose measurement using near-infrared LED is proposed in this project. The glucose level in the blood which is obtained from the photodetector is displayed in both the LCD display and the developed mobile app. This portable noninvasive blood glucose monitor provides a very effective means

for assisting the health care management of diabetic patients. This can be used for monitoring blood glucose level of the patients in the home as well as health care centers.

ADVANTAGES:

- low power consumption.
- Efficient design.
- Easy to operate.
- Low cost.

APPLICATIONS:

- Patients at homes ,old age homes ,hospitals.

REFERENCES:

- 1] Prof.Mrs.A.A. Shinde, “Non-Invasive Blood Glucose Measurement using NIR technique based on occlusion spectroscopy”, International Journal of Engineering Science and Technology (IJEST) ISSN: 0975-5462 Vol. 3 No. 12, pp. 8325-8333, December 2011.
- [2] Chi-Fuk So, Kup-Sze Choi, Thomas KS Wong, Joanne WY Chung, “Recent advances in noninvasive glucose monitoring”, Medical Devices: Evidence and Research. Vol.5, pp. 45-52, June 2012.
- [3] JyotiYadav, Asha Rani, Vijender Singh “Near-Infrared LED based Non-invasive Blood Glucose Sensor”, International conference on Signal Processing and Integrated Network (SPIN), IEEE, pp. 591-594, Feb 2014.
- [4] Christopher Dale Chua, Ian Mikhael Gonzales, Enrique Manzano, Maria Carla Manzano, “Design and Fabrication of a Non-Invasive Blood Glucometer Using Paired Photo-Emitter and Detector Near-Infrared LEDs”, DLSU Research Congress, De La Salle University, Manila, Philippines, March 2014.
- [5] JyotiYadav, Asha Rani, Viajnder Singh, BhaskarMoahnMurari, “Comparative Study of Different Measurement Sites using NIR Based Non-invasive Glucose Measurement system”, Procedia Computer Science, Elsevier, Vol. 70, pp. 469 – 475, 2015.
- [6] Parag Narkhede, Suraj Dhalwar, B. Karthikeyan. “NIR Based Non-Invasive Blood Glucose Measurement”, Indian Journal of Science and Technology, Vol. 9 No. 41, pp. 1-7, November 2016.
- [7] Maier JS, Walker SA, Fantini S, Franceschini MA, Gratton E., “Possible correlation between blood glucose concentra-tion and the reduced scattering coefficient of tissues in the near infrared”, Optics letters. Vol. 19 No. 41, pp. 2062-64, December 1994.