



Assessing The Performance Of Machine Learning Models In Recognizing Fraud In Financial Card Utilization

¹Mrs. L. Shalini, ²B. VV. Satyanarayana, ³Ch. Sriram, ⁴Ch. Rohith Kumar, ⁵ D. Charan Kumar Reddy,

¹Assistant professor Department of Computer Science and Engineering, Bharath Institute of Higher Education And Research, Chennai, India-600073 Student, Department of Computer Science and Engineering, Bharath Institute of Higher Education and Research Chennai, India-600073

Abstract

The boom of technologies including commercial enterprise technology and monetary technology (FinTech) has caused a large range. Online card transactions every day. Thus, the assault on credit score card fraud has affected card agencies. Merchants and Banks. Therefore, it is crucial to expand mechanisms that aid the security and integrity of credit transactions. In it Research Implementation of a Machine Learning (ML)based totally Platform to Detect Credit Card Fraud Using Diverse Real-World Datasets. European credit card holders are well-known. To address the problem of class inequality, they resampled the dataset with the usage of an artificial approach. Minority Extrapolation Technique (SMOTE). This platform has been evaluated the use of the subsequent device learning methods: Support Vector Machine. (SVM), Logistic Regression (LR), Random Forest (RF), Extreme Gradient Boosting (XGBoost), Decision Tree (DT), Spanning Tree (ET). These ML algorithms are blended with Adaptive Boosting (AdaBoost) to perform the stepped-forward category. Examples Precision, in mind, precision, Matthew's correlation coefficient (MCC), and location underneath the curve were evaluated. (AUK). The proposed framework generated

artificial confidence cardinality of a noticeably skewed fraud dataset to in addition validate the data. The consequences acquired on this study. Test results show that the use of AdaBoost has a tremendous impact Performance of the proposed approach. Additionally, the results acquired the usage of the advanced fashions are better than the prevailing techniques.

Keywords: Machine Learning, Strategies, Recognition,

INTRODUCTION

In current years, the increase of monetary fraud has been because of the development of technologies and paradigms inclusive of e-commerce. Financial Industry Technology (FinTech). The development of these technology has brought about an growth inside the quantity of credit transactions. The end result is a fast wave. Number of cases of economic fraud the usage of credit bureaus. Credit card fraud occurs whilst a crook makes use of a credit card in a valid or unauthorized way. This is completed via credit card. Authenticated facts is stolen through diverse fraudulent methods along with e-commerce transaction interception or account tracking. Present card It is critical to implement credit card fraud detection systems that make sure the integrity and protection of all systems worried in

fraud. Doing credit score card transactions. In this paper, we develop gadget gaining knowledge of (ML) algorithms for credit score card fraud detection which might be evaluated on a real-international dataset. Additional device getting to know strategies to bear in mind in this examine are: Support Vector

Machine (SVM), Random Forest (RF), and Complementary Tree. (ET), Extreme Gradient Boosting (XGBoost), Logistic Regression (LR) and Decision Tree (DT). These ML methods had been evaluated personally in line with their overall performance and excellent. In addition, adaptive development (AdaBoost) is related to each technique to improve its reliability.

OBJECTIVE

The motive of this record is to outline necessities for credit score card fraud detection. Specifically, this file will offer a preferred description of our venture, along with consumer necessities, product expectancies; and examination of necessities, commonplace barriers. It may even offer the particular requirements and features required for this venture such as interfaces; necessities and overall performance necessities.

RELATED WORK

1. Separation of actuaries into soft-contact employees ought to be recognized

Credit scoring is a term used to explain systematic statistical strategies for classifying loan candidates into "appropriate" and "bad" risk instructions. Such strategies have become more and more important due to the dramatic increase in patron lending in current years. Extensive statistical techniques were used, even though the literature is publicly available because of business confidentiality reasons. First, the issues that get up inside the context of credit scoring are reviewed and the statistical methods used are reviewed.

2. A evaluation of neural networks and linear scoring fashions inside the context of credit unions.

The cause of this paper is to research the competencies of neural networks such as multifaceted perceptrons and modular neural networks and conventional techniques consisting of discriminant evaluation and logistic regression

in growing scoring fashions in the context of a credit union. In addition, funding and small sample sizes frequently prevent using non-public loans at small credit unions, and we take a look at not unusual examples and compare person examples. Our outcomes show that neural networks are very promising for diversion if the overall performance measure of percentage of terrible loans is well exact. However, if the overall performance measure is the percentage of efficaciously categorized right and terrible loans, logistic regression models are similar to the neural community technique. The typical performance of the fashions is not as properly as the man or woman models, especially when bad loans are properly digested. Although we determined extensive differences within the outcomes of the 3 credit unions, our modular network changed into unable to account for those variations, indicating that extra centre structure is needed to broaden useful models.

3. Credit Scoring Methods. Journal of the Czech Economic and Economic Association

An article at the maximum developed and frequently used credit scoring techniques used by industrial banks whilst evaluating loan applications. The author's cognizance on retail credit research - confined carried out research in this class, although in current years there has been a sharp growth in lending to retail clients. Logit evaluation is taken into consideration to be the maximum commonplace credit scoring approach used by banks. However, different non-parametric methods are widely used for sample popularity. The methods mentioned have capability software in nations undergoing a transition period.

4. Research on Credit and Behavioural Scoring: Predicting: Financial danger of lending to clients

Credit scoring and credit scoring are methods that help companies decide whether or not to grant credit score to their clients. This article explores statistical and operational studies-based techniques to help these conclusions. He discusses the need to include monetary conditions into scoring structures and how those systems can circulate lending establishments from assessing the probability of failure to assessing patron profitability—two key trends within the field. This suggests how a success the area become in

predicting monetary hazard. 2000 B.V. All rights reserved.

5. Neural networks as compared to standard credit score scoring structures within the Egyptian banking industry

In parallel with the modern-day economic crisis, the wide variety of non-performing loans has improved in current years, increasing the significance of credit score rankings. This look at proposes a 3-hybrid degree adaptive neural-fuzzy inductive credit scoring version based totally on statistical strategies and neural fuzzy structures. The overall performance of the proposed model became in comparison with traditional and widely used fashions. Credit scoring fashions had been tested the use of a ten-fold go-validation procedure with credit card statistics from international banks operating in Turkey. Results show that the proposed version always outperforms linear discriminant analysis, logistic regression, and synthetic neural community (ANN) procedures primarily based on average correct classification and misclassification estimates. As in ANN, the model has a gaining knowledge of objective; unlike an, the model will not be in a black box. In the proposed version, the translation of independent variables can offer treasured information to banks and customers, especially to explain why loan packages are rejected.

6. Credit Scoring Model for Retail Banking in Vietnam.

As the banking market in developing international locations develops, banks face opposition now not handiest from other home banks however additionally from skilled foreign banks. With massive boom in lending and increased regulatory awareness on danger management, it's miles imperative to develop a properly-functioning credit score scoring machine. In this framework, we propose a scoring version for Basque retail credit score. First, we're going to display you a way to get the credit score a borrower wishes that is part of the credit score scoring version. Second, we provide an explanation for how such a model can be calibrated to achieve the financial institution's strategic targets. Finally, we use credit score models within the context of credit transactions and loans.

EXISTING SYSTEM

If credit score fraud is detected, the gadget detects the fraud after the fraud has come about. When a patron will become privy to a discrepancy in a transaction, registers a complaint and uses a fraud detection gadget, the present device collects big amounts of statistics. Primarily, because of the fraud detection mechanism advanced by means of Master and Visa cards, agencies try and discover that fraud has truly occurred after they were used. Classification of machine studying paradigms with simple facts fraud detection. Intrusion detection to discover the vicinity of the fraud, in an current machine, there's no evidence of fraud and recuperation.

Customer satisfaction. A comfy digital machine is used to investigate the conduct of legitimate customers. Data mining strategies for type and preliminary consumer records. A genetic set of rules.

DISADVANTAGES

Each fee technique has its very own restrictions on the most amount

Account, quantity of transactions per day and range of withdrawals.

- If your Internet connection fails, you will not be able to access the Internet account.
- If you follow safety rules, the hazard is less. Worst case situation

It effects while an employer's method device breaks down

Collection of personal records approximately playing cards and their owners.

- Information about all transactions along with quantity, time and

The recipient is saved in the payment gadget's database. And on this manner

The intelligence business enterprise has accessed this facts. Sometimes it's far

This is a fraudulent exercise.

PROPOSED SYSTEM

The important reason of this assignment is to broaden models to be expecting credit card. A fraudulent contract. Let's attempt to prepare the

scholarship. For the sake of necessity. We use a random woodland algorithm framework for class and regression of datasets. First of all Credit card data collection and evaluation may be performed on the collected data. After studying the facts set, we need to smooth the facts set. Usually in some data set. There can be a lot of duplicates and null values, so get rid of all of them Duplicate and null values are required. Cleansing manner. Next, let's cut up the records set Bilateral learning dataset and test for comparison and evaluation. Data Set After dividing the information into elements, a random set of rules must be used. This algorithm will supply us higher accuracy in credit score card fraud are finished via applying the Random Forest algorithm to classify the records set in line with the no

Four classes are obtained within the form of a confusion matrix. It is established Classification analysis of overall performance records might be accomplished above. In this analysis. It is viable that valid credit score card fraudulent transactions will ultimately occur. Presented in a photo representation shape.

ADVANTAGES OF PROPOSED SYSTEM

Get alerts if suspicious interest is detected in your card. A company will notify you of any unusual expenses for your card. Credit scores rely upon many elements and whilst someone uses credit score. Card cognizance and well-timed payments without closing dates or overdue bills Released, credit score rises. By paying on time and keeping your card balance low. A character saves cash simplest on the card's interest fees Provider Friendship, not requiring non-public presence, is related to development Hello, time to shop.

SYSTEM ARCHITECTURE:

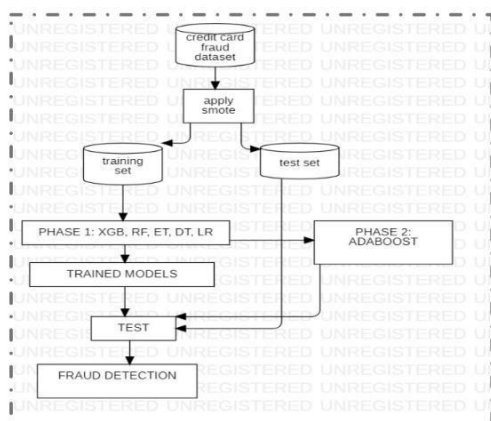

DATA FLOW

An information flow diagram (DFD) is a twodimensional diagram that describes how Data is processed and sent to the laptop. Recognizes a photograph picture How every information supply intersects with different statistics assets to reap mutual advantage;

To create the problem information waft desk, we need identify external inputs and outputs. Determine how inputs and outputs relate to each different. Explain graphically how those hyperlinks are linked and what they do.

Function of DFD

- Ensures that each programmers understand the documentation.
- Neither are the torturers. Because the DFD only says that the technique isn't strolling.
- How they are executed.
- A physical DFD requests in which the facts flows and who methods it.
- It allows the researcher to prepare and examine areas of hobby
- By analysing the data going into the process and seeing the way it changes. When they arrive out.

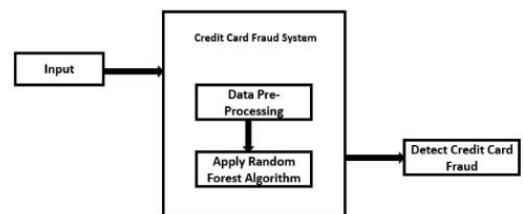

USE CASE DIAGRAM

Using options. Review. They are useful

To give displays to management and/or managers, but for motion. You will locate that the development offers extensively greater use cases. They describe technology requirements as "engaged". A use case is defined, A collection of movements that offer a few measurable value to movements and main to a horizontal ellipse.

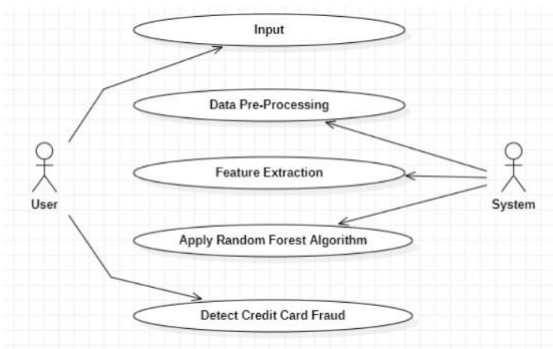

SEQUENCE DIAGRAM

The following determine illustrates the logic float on your pc. It's a visible way for each of you to record and test your common sense. Commonly used for evaluation and making plans. The following is a table. The most famous UML method for dynamic modelling focuses on identity behaviour in your device.

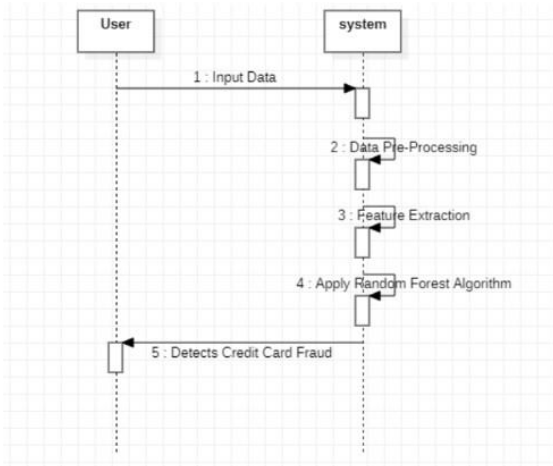

ACTIVITY DIAGRAM

Activity charts are graphical representations of stepby means of-step hobby workflows and hobby-based totally analysing, repetition, and integration. Movement. A diagram may be used to explain business and operational reput Work strategies are part of the system. The movement diagram of the node is at the beginning, End-to-stop decisions and movements among them.

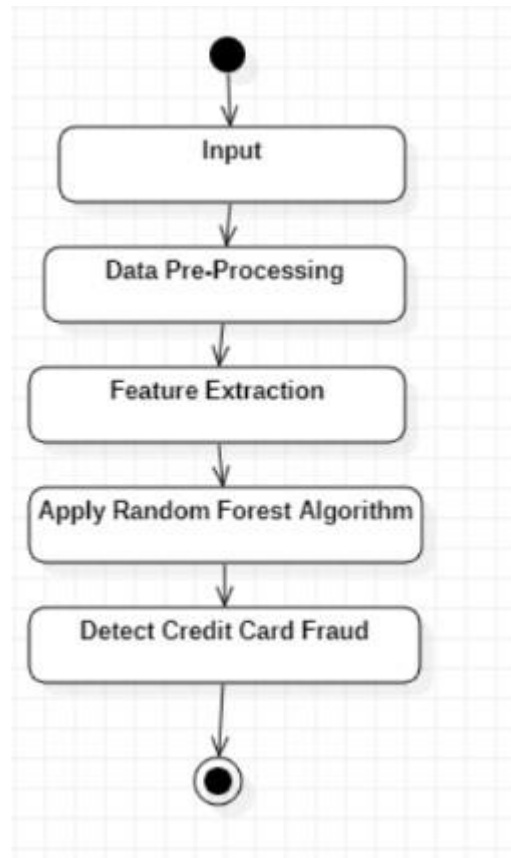

SYSTEM REQUIREMENTS

Hardware Requirements

- System: Pentium IV 2.4GHZ
- Hard Disk: 40 GB
- Ram: 512 Mb

Software Requirements

- Operating system: Window 7(32 bit)
- Coding Language: Python
- Tool: Flask/Jupyter Notebook

MODULES

1. Data collection module

This is the primary actual step closer to the actual improvement of device learning. Sampling, information series is a vital step that can be as high as feasible. The model will remain, and the greater and higher information we get, the higher our model will be it will work. There are many methods of accumulating records like network, manual steering etc. Interference and so forth. D.

2. Pre-processing module

- We will change the records. Remove the lacking information by using deleting it. A few paragraphs. First let's create a listing of the column names we need to keep or keep.
- Then we reset or delete all columns besides those we want behavior
- Finally, we insert or do away with rows that haven't any values inside the records ornament

3. Feature extraction

While constructing a system studying model, we need two units of records, one Practice for testing and others. But now we simplest have one. This may be separated later. Two in 80:20 ratio. We additionally cut up it right into a DataFrame feature Columns and columns.

- A educate ride in Sklearn. Then use it to separate. The facts set is likewise, `test_size = zero.2`, which splits with eighty% as the teach statistics set 20% of the take a look at records set.
- The seed parameter is random state, a random wide variety generator that enables Split the records set.
- The function returns 4 portions of data. Named `train_x`, `train_y`, `test_x`, `test_y`. If you can see the sample of those records, you may see the distribution of the data sets.
- We used random forest classifier which suits a couple of selection trees. Information Finally, I installation the version through passing `Train_x`, `Train_y` in matching mode.
- After the model is fashioned, it's miles important to check the version. This is what we need pass `test_x` to expect the mode.

4. Fraud Detection using Random Forest Algorithm

In this module, the laptop has to decide whether any fraud has befall. Whether it actually happens or no longer. It must additionally show the user about the event.

5. Accuracy on test set

- We got a accuracy of 0.93% on test set.6. Fraud detection

6. Saving the Trained Model

Once you're confident enough to take your trained and tested model into the production-ready environment, the first step is to save it into a .h5 or .pkl file using a library like pickle. Make Sure you have pickle installed in your environment. Next, let's import the module and dump the model into .pkl file.

Algorithm used

Random Forest Algorithm

- Random jump is a totally powerful and broadly used classifier Algorithms in Machine Learning. It consists of the range of unique choice timber And take recommendation. It has simplicity and range from which it can be Performs sort and regression operations.

Footsteps

1. Select n random information from the statistics set.
2. Construct a choice tree from these N inputs.
3. Choose the variety of bushes you want to your set of rules and repeat step 1 and II.
4. during the regression hassle, every tree for a brand new file. The wooded area predicts the value for y (output).

RESULT AND DISCUSSION

In this article we mentioned how random forests are used. Fraud detection in on line credit score card transactions. Proposed Fraud. The detection gadget additionally scales to handle big amounts of transaction facts Cure Forest isn't always a random credit card fraud detection system. As an current machine there's a complex procedure to test fraud. Proposed Fraud detection device gives actual and faster consequences than the present system. A The random woodland detection technique is very simple Structure is detected by well-processing random forests. It attempts to simplify and put off complexity.

FUTURE SCOPE

We are about to use for random wooded area on credit card. Fraud detection. A credit score card transaction involves several steps. The system is based on a fundamental stochastic method.

Random forests. We have a look at the problem of your desire Observations have been symbols, however an element of kind ought to be considered as uneventful stages of forests. We have proposed method of searching profile of exempted cardholders; as well as the utility of this information to decide value. Initial estimation of version indices and version parameters. This is How can a random wooded area come across. Whether the transaction is fraudulent or now not. Reason too Scalable to process large volumes of transactions.

CONCLUSION

In this newsletter we mentioned how a forest may be random. This is useful for detecting fraudulent online credit card transactions. The proposed fraud detection gadget is likewise tractable MGE's largest transaction volumes. Random wooded area. A credit card fraud detection machine is not complex. Validating the process for fraud as an current machine. Proposed A fraud detection machine provides a real and quicker answer than one Applications,35, 1275-1292, 2008.

REFERENCE

- [1] D. J. Hand and W. E. Henley, Statistical classification methods in consumer credit scoring: A review. *Journal of the Royal Statistical Society: Series A (Statistics in Society)*, 160(3), 523–541, 1997.
- [2] V. S. Desai, J. N. Crook and G. A. Overstreet, A comparison of neural networks and linear scoring models in the credit union environment. *European Journal of Operational Research*, 95(1), 24–37, 1996.
- [3] M.Vojtek and E. Kocenda , Credit Scoring Methods. *Czech Journal of Economicsand Finance*, 56(3-7), 152-167, 2006.
- [4] L. C. Thomas, A survey of credit and behavioral scoring: forecasting: financial risk of lending to customers. *International Journal of Forecasting*, 16, 149-172, 2000.

and tries to get rid of Complicated conventional techniques in credit scoring in Egyptian banking.

nets versus Expert System [5]H. Abdou, J. Pointon,

and A. El-Masry, Neural

- [6] T.H.T. Dinh, and S. Kleimeier, A credit scoring model for Vietnams retail banking market. *International Review of Financial Analysis*, 16, 471- 495, 2007.
- [7] X. Zhang, Y. Han, W. Xu, and Q. Wang, “HOBA: A novel feature engineering methodology for credit card fraud detection with a deep learning architecture,” *Inf. Sci.*, May 2019.
- [8] N. Carneiro, G. Figueira, and M. Costa, “A data mining based system for credit-card fraud detection in e-tail,” *Decis. Support Syst.*, vol. 95, pp. 91–101, Mar. 2017.
- [9] B. Lebichot, Y.-A. Le Borgne, L. He-Guelton, F. Oblé, and G. Bontempi, “Deep-learning domain adaptation techniques for credit cards fraud detection,” in *Proc. INNS Big Data Deep Learn. Conference*, Genoa, Italy, 2019, pp. 78–88.
- [10] H. John and S. Naaz, “Credit card fraud detection using local outlier factor and isolation forest,” *Int. J. Comput. Sci. Eng.*, vol.7, no. 4, pp. 1060–1064, Sep. 2019.
- [11] J. Jurgovsky, M. Granitzer, K. Ziegler, S. Calabretto, P.-E. Portier, L. He-Guelton, and O.

Caelen, “Sequence classification for credit card fraud detection,” *Expert Syst. Appl.*, vol. 100, pp.234–245, Jun. 2018.

[12] U. Fiore, A. D. Santis, F. Perla, P. Zanetti, and F. Palmieri, “Using generative adversarial networks for improving classification effectiveness in credit card fraud detection,” *Inf. Sci.*, vol. 479, pp. 448– 455, Apr. 2019.

[13] Credit Card Fraud Dataset. Accessed: Sep. 4, 2019. [Online]. Available: <https://www.kaggle.com/mlg-ulb/creditcardfraud/data>.

[14] I. Mekterović, L. Brkić, and M. Baranovi, “A systematic review of data mining approaches to credit card fraud 106 detection,” *WSEAS Trans. Bus. Econ.*, vol. 15, p. 437, Jan. 2018. [15] M. A. Al-Shabi, “Credit card fraud detection using auto encoder model in unbalanced datasets,” *J. Adv. Math. Comput. Sci.*, vol. 33, no. 5, pp. 1–16, 2019.

[16] S. V. S. S. Lakshmi and S. D. Kavilla, “Machine learning for credit card fraud detection system,” *Int. J. Appl. Eng. Res.*, vol. 13, no. 24, pp. 16819–16824, 2018.