



SIMULATION AND ANALYSIS OF DC-DC BOOST CONVERTER USING PSPICE SOFTWARE PROGRAM

¹N.Dinesh kumar, ²S.Dhivya, ³B.Ganga & ⁴R.Palani

¹⁻⁴Department of Physics, Annamalai University, Chidambaram, Tamil Nadu, India- 608002.

Abstract: The DC-DC converter has been focused as a very important part in different topologies in various applications. In recent years, DC-DC converters have become a popular device in electric vehicles, trolley cars, marine hoists, photovoltaic (PV) systems, uninterruptible power supplies (UPS) and fuel cell systems. The purpose of this paper is to demonstrate the design of a functional prototype of a DC-DC boost converter that can be used for 9-24 V and 9-48 V. DC-DC boost converter is basically a step-up converter that gives higher output voltage (V_o) compared to input voltage (V_{in}). It steps up the input voltage in order to achieve a higher output voltage. The boost converter, also known as a switch mode regulator, is popular due to its high efficiency and low cost. The voltage source and duty cycle play a crucial role in determining the output voltage. The boost converter circuit is crafted with MOSFET, resistor, capacitor, inductor, and diode. The boost converter's working principle is based on the inductor's ability to resist changes in current as its components. The Pspice software program is used to simulate and analyze the boost converter. The converter circuit model, with a specification of output power of 50W, input voltage of 9V, and operating frequency of 46kHz, was simulated to validate the designed parameters. The simulation results of the boost converter are assessed against the theoretical results.

Keyterms- Boost converter, prototype, switch voltage, power supply, ripple voltage and ripple current.

I.INTRODUCTION

Power DC-DC converter (step up /step down) are gaining ever-increasing importance due to its enormous advantages. The interest on a compatible power DC-DC converter is increasing recently for obtaining desired power conversion in different fields like renewable energy, high and medium power application etc¹. It almost plays a role similar to that of the transformer of an ac system². The widespread use of battery operated portable devices such as cell phones and laptops has created the needs for DC –DC conversion power supplies such as switched mode power supplies³. In the present power scenario, the utility is very less whereas the power consumption is increasing. This leads to a greater demand of supply and the renewable energy sources are of main importance. The energy must be stored and used and the batteries play a vital role. Direct current source are the batteries and the voltage from the batteries are controlled by the DC-DC converter. The DC-DC converters using power electronic switches and passive storage elements are designed depending upon the application. High intensity discharge lamps are used in automobiles and require a power rating of 40W and DC voltage of 96V. The requirement of supply can be provided by a battery, but it occupies a very big space in the automobiles. Hence, a DC-DC boost converter is used which

boosts the voltage of the supply to the required voltage. This is possible by designing the converter. For large boost of DC voltage, high step up boost converters are used and each and every converters have their own merits and demerits⁴. A lot of researchers are done in this aspect to derive a converter with reduced losses, reduced cost, high efficiency, increased time response and reduced redundant power processing⁵. Basically boost converters having high demand where high dc voltage is required⁶. The SPICE, the acronym for a Simulation Program with Integrated Circuit Emphasis, was developed at the University of California Berkeley, USA. Pspice is a commercial version, developed by Microsim Corporation⁷. PSpice simulation of the step-up dc-dc converter has been done to verify the designs⁸.

The main objective of this paper is to design a dc boost converter with much reduced losses, high efficiency and simple structure with reduced cost for the operation. The steady state analysis for the proposed converter in continuous conduction mode is also to be presented. This paper contains the topology of the basic boost converter is given in section II. The modes of operation are presented in section III. Design methodology of boost converter is presented in section IV. Section V describes the converter with simulation results using pspice. Performance analysis of the proposed converter is given in section VI. Section VII summaries the conclusions drawn from the proposed converter topology.

II. TOPOLOGY

The topology of basic dc-dc boost converter is shown in the Fig.1 which consists of single inductor L, diode D, switch S and capacitor C. In the proposed converter, the duty cycle for the switch is given as 66.3% and 83.7% respectively and the switch is used as MOSFET.

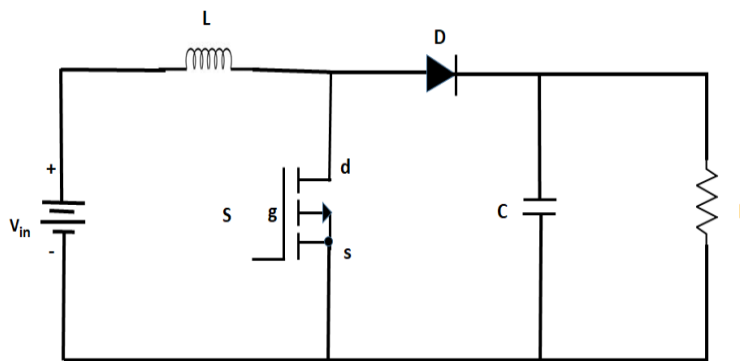

Fig.1. Basic dc-dc boost converter

III. MODES OF OPERATION

Boost converter operation based on two modes. They are

1. Mode I: switch S is ON and diode D is reverse biased.
2. Mode II: switch S is OFF and diode D is forward biased.

Mode I: Switch S is ON and diode D is reverse biased

In this mode of operation, switch S is in closed condition i.e., ON state, and diode D is in open condition i.e., reverse biased. Thus switch S allows the flow of current through it. All the current will flow through the closed path including the inductor L, switch S, and back to the dc input source. The circuit diagram for this mode is shown in the Fig 2.

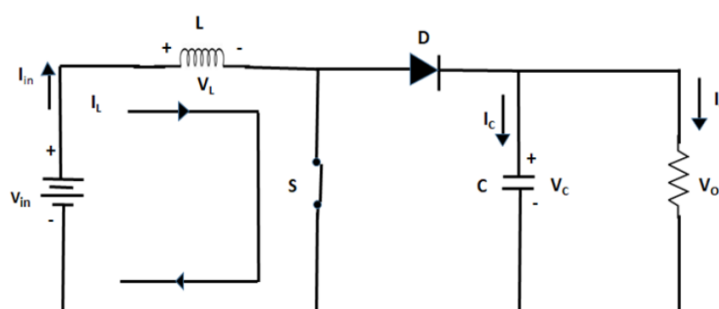

Fig.2. Boost converter circuit when switch S is closed

Here, the polarity of the inductor will be according to the direction of the flow of current. In this mode of operation, the diode D is in reverse biased condition so that the diode does not allow the flow of current through the load causing the output stage to be isolated from the input. The voltage across the inductor is same as the input voltage $V_L=V_{in}$ and $I_C = -I_o$.

Mode II: Switch S is OFF and diode D is forward biased

In this mode of operation, switch S is in open condition *i.e.*, OFF state and diode D is in closed condition *i.e.*, forward biased. Thus, the switch diode D allows the flow of current through it, whereas switching S blocks the current flow through it. The circuit diagram for this mode is shown in the Fig 3.

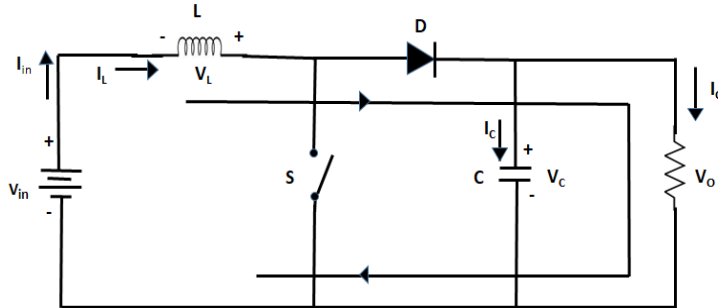

Fig.3. Boost converter circuit when switch S is open

As we know, the inductor in the circuit store energy in the form of the magnetic field, the inductor acting as the source when the switch S is open. Hence diode D is in forward biased. In this mode of operation, the inductor releases the energy stored in the previous mode when switch S was closed. During the releasing of energy stored in the inductor, the polarity of the inductor gets reversed which cause the diode D to come in forward biased condition. So, it allows the current flows towards the load. The released energy is ultimately dissipated in the load resistance which helps to maintain the flow of current in the same direction through the load and also steps up the output voltage $V_L=V_{in}-V_o$ and $I_C = I_L-I_o$.

IV. DESIGN OF THE PROPOSED BOOST CONVERTER

The power rating for the load is 50W and the output voltages are 24V and 48V respectively. Thus the input voltage is taken as 9V⁹.

i) Resistance: (R)

$$R = \frac{V_o^2}{P} \quad \text{-----(1)}$$

where V_o is the output voltage

ii) Duty cycle: (D)

$$D = 1 - \frac{V_{in}}{V_o} \quad \text{-----(2)}$$

where V_{in} is the input voltage. Using the value of D, the values of inductance and capacitance can be calculated.

iii) Inductance: (L)

$$L = \frac{D(1-D)}{2f} \times R \quad \text{-----(3)}$$

where f is the switching frequency.

iv) Capacitance: (C)

$$C = \frac{D}{2fR} \quad \text{-----(4)}$$

v) Output current (I_o)

$$I_o = \frac{P_o}{V_o} \quad \text{-----(5)}$$

where P_o is the output power

vi) Ripple voltage: (ΔV)

$$\Delta V = \frac{DI_o}{f \times C} \quad \text{-----(6)}$$

vii) Ripple current: (ΔI)

$$\Delta I = \frac{DV_S}{fL} \quad \text{-----(7)}$$

viii) Efficiency: (η)

$$\eta = \frac{\text{output power}}{\text{input power}} \quad \text{-----(8)}$$

To obtain the ps Spice simulation results, the parameters of the non-ideal boost converter under consideration are given in Tables 1-2.

Table.1. Design parameters of conventional boost converter for 9-24V

PARAMETERS	SYMBOLS	VALUES	UNITS
Input voltage	V_{in}	9	V
Inductor	L	60	μH
Capacitor	C	50	μF
Resistor	R	11.52	Ω
Duty cycle	D	66.3	%
Pulse width modulation	T_{on}	14.4	μs
Switch frequency	F	46	kHz
Power	P	50	W

Table.2. Design parameters of conventional boost converter for 9-48 V.

PARAMETERS	SYMBOLS	VALUES	UNITS
Input voltage	V_{in}	9	V
Inductor	L	152	μH
Capacitor	C	80	μF
Resistor	R	46.08	Ω
Duty cycle	D	83.68	%
Pulse width modulation	T_{on}	18.19	μs
Switch frequency	f	46	kHz
Power	P	50	W

V.RESULT AND DISCUSSION

Simulation is used to predict the performance of the circuit before hardware implementation. The simulation model of the DC-DC boost converter (non-ideal effects of the components) is shown in Fig. 4 and 5. These circuits are simulated in PSpice with $V_{in}=9\text{v}$, $L=60\mu\text{H}$, $152\mu\text{H}$, $C=50\mu\text{F}$, $80\mu\text{F}$, $R=11.52\ \Omega$, $46.08\ \Omega$ and MOSFET (IRF540) with a switching frequency of 46kHz. Switching frequency selection is usually determined by efficiency requirements. Figs 6-7 show the switching pulse for 9V-24V and 9V-48V boost converters when the duty cycle is 66.3% and 83.6% respectively. A 5 volt gate pulse was applied to the MOSFET switch. The performance of the system is evaluated using the simulated results. The simulation results of the performance of boost converters are given in Table 3. The output voltage of the boost converter depends on the duty cycle and input voltage. Since the input voltage is constant, changing the duty cycle allows us to control the output voltage. The duty cycle can be varied by changing the PWM of the switching pulse. The output voltage is directly proportional to the charging time (T_{ON}) of the pulse.

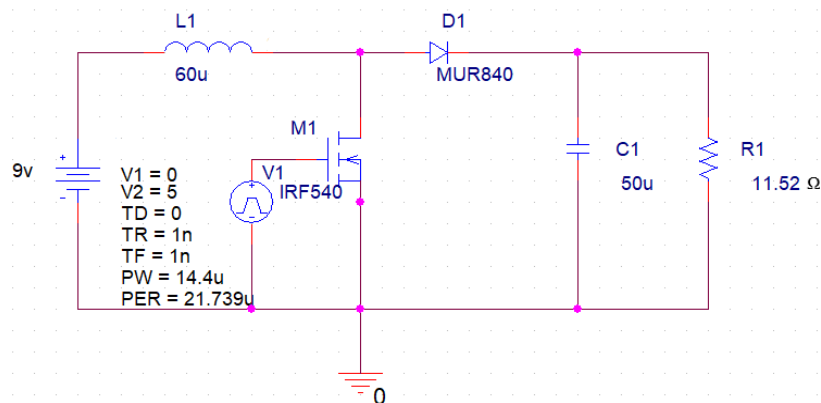

Fig.4. Simulation circuit of proposed boost converter (9-24V) using pspice

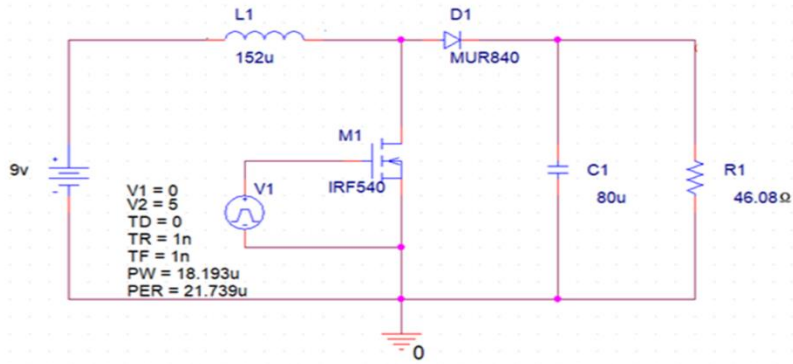

Fig.5. Simulation circuit of proposed boost converter (9-48V) using pspice

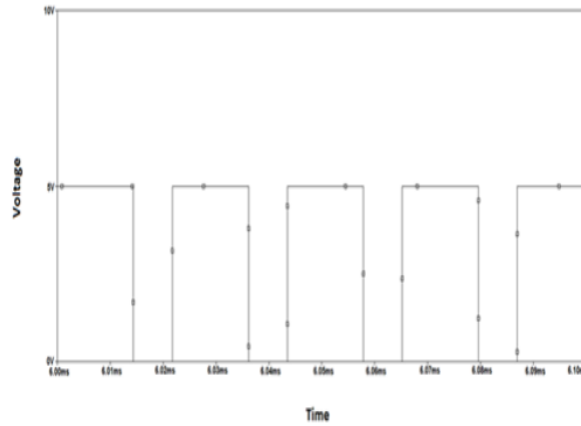

Fig.6. Switching pulses of boost converter using pspice (9-24V)

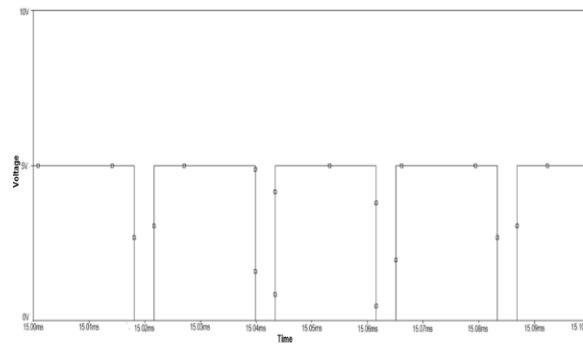

Fig.7. Switching pulses of boost converter using pspice (9-48V)

Figs 8-13 display the simulation outcomes for voltage, current, and power waveforms of boost converters. Fig 8 shows the waveforms of V_{in} , V_L , V_S , V_D , V_C and V_O of the designed boost converter for 9V.

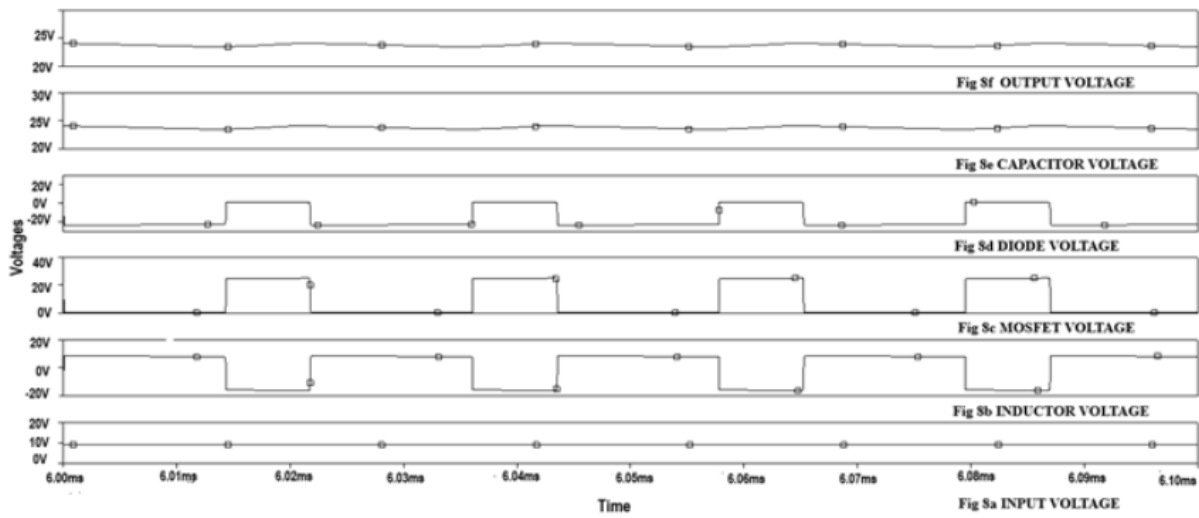

Fig.8. Voltage waveforms of boost converter for 9V-24V

Fig.8a shows the waveforms of the input voltage at 9V for the proposed boost converter. The voltage across the inductor is shown in Fig 8b. In the ON and OFF states of the switch, the voltage polarity is opposite. The switch voltage is +8.4V when the inductor is on and -16.1V when it's off. The above voltage is observed when the input source is connected to a 9V supply. Further, Fig. 8c and 8d represent the voltage across the MOSFET and diode. When the MOSFET and diode are on, the voltage across them reaches 0.6V. Figures 8e and 8f demonstrate the voltage across the capacitor and load of the proposed boost converter. From the waveform, we achieved a constant regulated output voltage of 24V without any ripples during both the ON and OFF states.

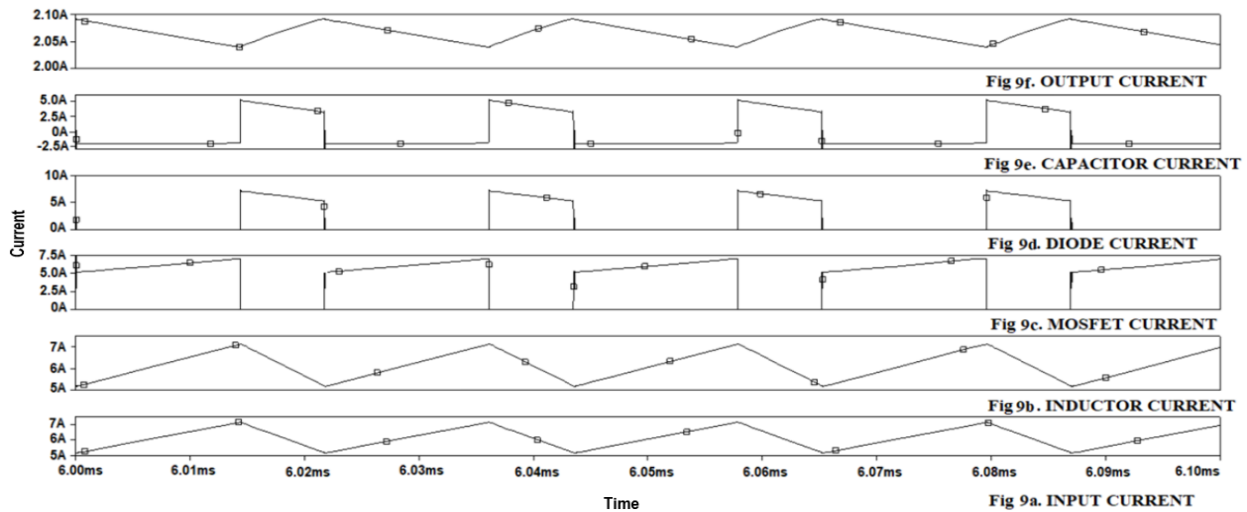

Fig.9. Current waveforms of boost converter for 9v-24v

Fig.9 shows the current waveforms of the input, inductor, MOSFET, diode, capacitor, and load of the boost converter with a voltage range of 9V-24V. Figs. 9a and 9b show the current waveforms of an input supply and an inductor. From these waveforms, we observed that the value of input current and inductor current is identical at 7.15A. Moreover, as shown in Figs 9c and 9d, the MOSFET and diode currents were 7.15A and 7.31A.. Fig 9e represents the capacitor current waveform. During the ON state, the current across the capacitor becomes -2.09A, and during the OFF state, it becomes 5.27A. As seen in Figure 9f, the output current value is 2.09A.

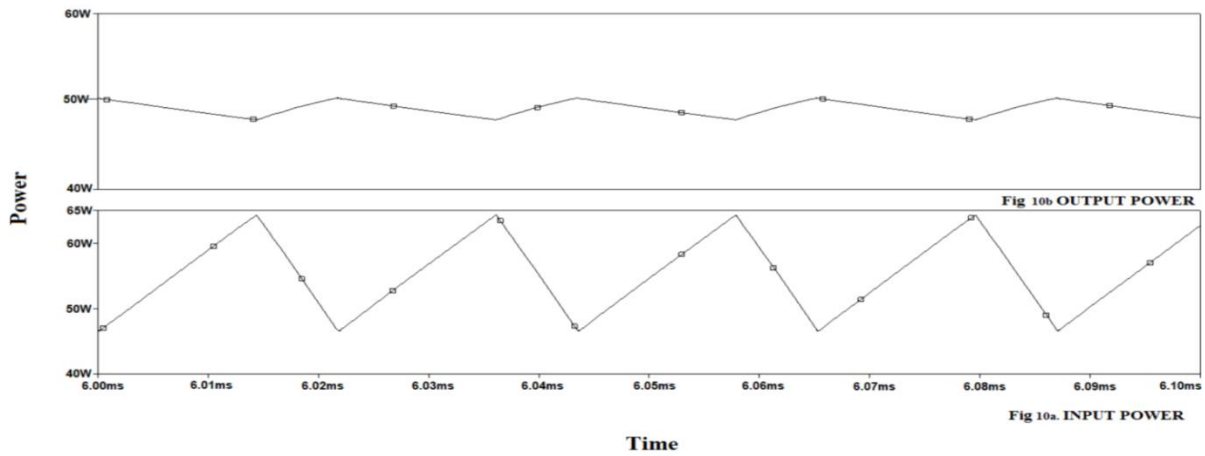

Fig.10.Power waveforms of boost converter for 9v-24v

Fig.10. Provides a visual representation of the power waveforms for the boost converter for 9V-24V. The waveforms of input and output power of the designed boost converter are depicted in Figs. 10a and 10b. The input and output power of 64.3W and 50W were confirmed by analyzing these waveforms.

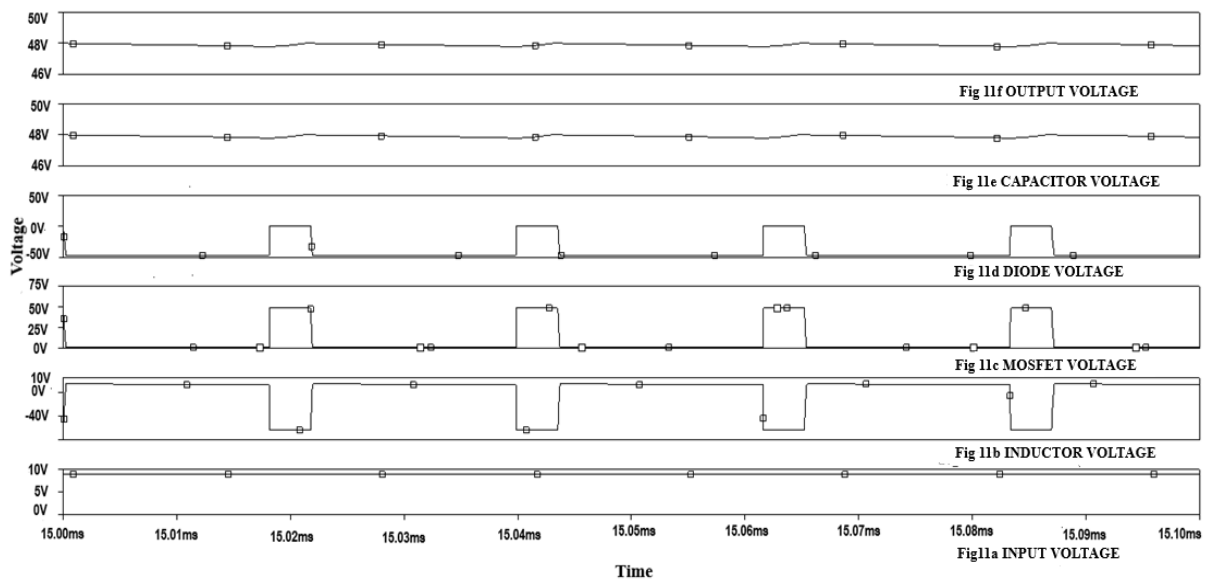

Fig.11. Voltage waveforms of boost converter for 9v-48v

Fig.11a shows the waveforms of the input voltage at 9V for the proposed boost converter. The voltage across the inductor is shown in Fig 11b. In the ON and OFF states of the switch, the voltage polarity is opposite. The switch voltage is +8.3V when the inductor is on and -40.1V when it's off. The above voltage is observed when the input source is connected to a 9V supply. Further, Fig. 11c and 11d represent the voltage across the MOSFET and diode. When the MOSFET and diode are on, the voltage across them reaches 0.6V. Figures 11e and 11f demonstrate the voltage across the capacitor and load of the proposed boost converter. From the waveform, we achieved a constant regulated output voltage of 48V without any ripples during both the ON and OFF states.

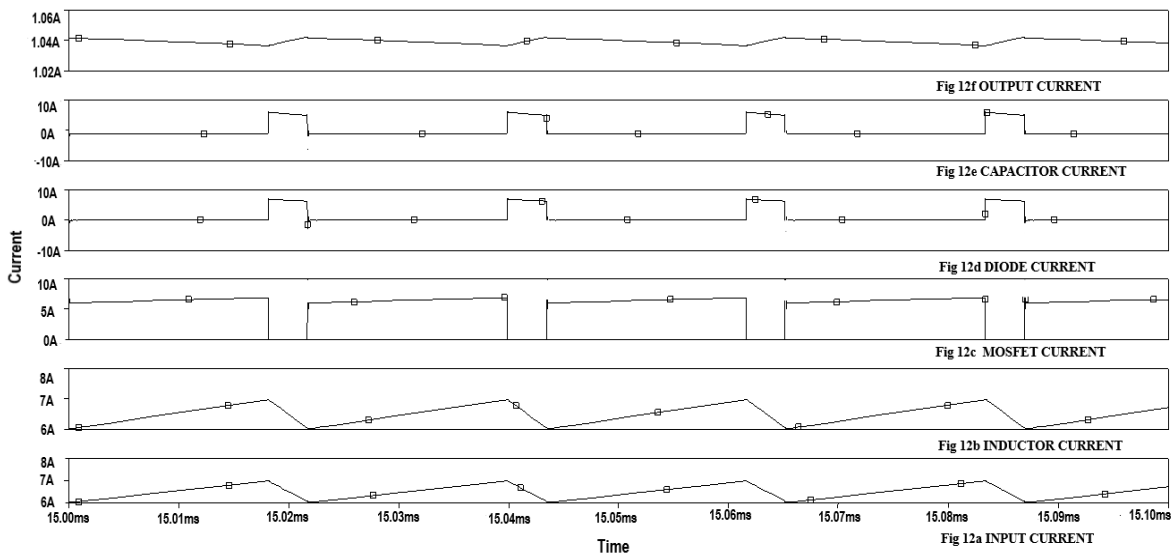

Fig.12. Current waveforms of boost converter for 9v-48v

Fig.12 shows the current waveforms of the input, inductor, MOSFET, diode, capacitor, and load of the boost converter with a voltage range of 9V-48V. Figs. 12a and 12b show the current waveforms of an input supply and an inductor. From these waveforms, we observed that the value of input current and inductor current is identical at 6.99A. Moreover, as shown in Figs 12c and 12d, the MOSFET and diode currents were 6.87A and 7.27A. Fig 12e represents the capacitor current waveform. During the ON state, the current across the capacitor becomes -1.04A, and during the OFF state, it becomes 6.23A. As seen in Figure 12f, the output current value is 1.04A.

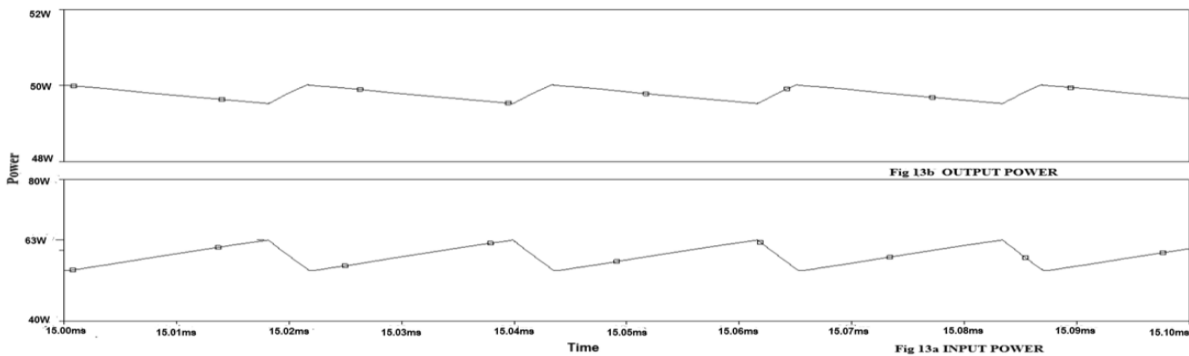

Fig.13. Power waveforms of boost converter for 9v-48v

Fig.13. Provides a visual representation of the power waveforms for the boost converter for 9V-48V. The waveforms of input and output power of the designed boost converter are depicted in Figs. 13a and 13b. The input and output power of 62.9W and 50W were confirmed by analyzing these waveforms.

Table.3. Simulation results of boost converters performance

PARAMETERS	SYMBOLS	SIMULATION RESULTS				UNITS
		FOR 9-24V		FOR 9-48V		
		ON	OFF	ON	OFF	
INPUT VOLTAGE	V_{in}	9		9		V
SWITCH FREQUENCY	F	46		46		kHz
GATE VOLTAGE	V_g	5	0	5	0	V
INDUCTOR VOLTAGE	V_L	8.4	-16.1	8.3	-40.1	V
MOSFET VOLTAGE	V_{ds}	0.6	25.1	0.6	48.5	V
DIODE VOLTAGE	V_d	-23.5	1.15	-47.3	0.53	V
CAPACITOR VOLTAGE	V_c	23.5	24.1	48.0	47.7	V
OUTPUT VOLTAGE	V_o	23.5	24.1	48.0	47.7	V
RIPPLE VOLTAGE	V_r	0.60		0.23		V
INPUT CURRENT	I_{in}	7.15	5.17	6.99	6.03	A
INDUCTOR CURRENT	I_L	7.15	5.17	6.99	6.03	A
MOSFET CURRENT	I_{ds}	7.15	-0.16	6.87	-0.27	A
DIODE CURRENT	I_d	7.31	0	7.27	0	A
CAPACITOR CURRENT	I_c	-2.09	5.27	-1.04	6.23	A
OUTPUT CURRENT	I_o	2.09	2.04	1.04	1.03	A
RIPPLE CURRENT	I_r	2.15		1.07		A
INPUT POWER	P_{in}	64.3	47.9	62.9	54.2	W
OUTPUT POWER	P_o	50.4	46.6	50.0	49.5	W
EFFICIENCY	η	78	97	79	91	%

Table.4. Comparison of simulation results and theoretical results of boost converter.

PARAMETERS	THEORETICAL RESULT		SIMULATION RESULT	
	9-24V	9-48V	9-24V	9-48V
Duty cycle(%)	62.5	81.25	66.3	83.68
Inductor voltage(V)	9	9	8.4	8.3
Capacitor voltage(V)	24	48	24	48
Output voltage(V)	24	48	24	48
Ripple voltage(V)	0.60	0.23	0.61	0.25
Capacitor current(A)	-2.08	-1.04	-2.09	-1.04
Output current(A)	2.08	1.04	2.09	1.04
Ripple current (A)	2.15	1.07	1.95	0.97
Efficiency(%)	80	80	80	80

Table.4. Compares the simulation results with the theoretical results of the designed boost converter. The simulation results are closely related to the theoretical results, as shown in the table above.

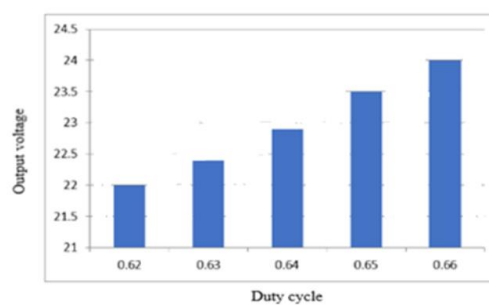

Fig.14. Output voltage versus duty cycle of 9V-24V boost converter

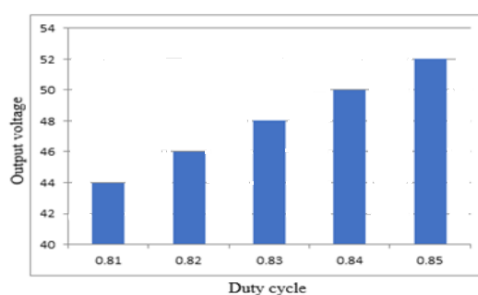

Fig.15. Output voltage versus duty cycle of 9V-48V boost converter

Figs 14 and 15 show the output voltage versus duty cycle for 50W prototype boost converters for 9V-24V and 9V-48V. An increase in duty cycle value leads to an increase in the output voltage of the boost converter. The boost converter's output voltage is influenced by the specific duty cycle.

CONCLUSION

In this paper, we examine the effective design and development of a DC-DC boost converter that utilizes low source voltage. The converter's design was done with an LT Spice XVII simulation tool and PSpice provided by the suppliers. The converter utilizes a simple circuit with a single switch and requires a minimal quantity of components. The simulation results indicate that the switching converter enhances the voltage by boosting from 9V to 24V and 9V to 48V, featuring low voltage and current ripple, and an efficiency of 80%. Theoretical results and simulation results are nearly identical. The simulation results that were obtained using PSpice give a comprehensive overview of the hardware's function and prepare us for the expected outcomes. Thus, the converter design's efficiency is improved and errors are minimized.

ACKNOWLEDGEMENT

The authors express their gratitude to Dr.C.Rakkappan, The Head of the Department, Department of Physics, Annamalai University, Chidambaram for his unwavering support and assistance in ensuring the smooth completion of this project.

REFERENCES

- [1] Hossain.M.Z, Rahim.N.A, Selvaraja.J.A, "Recent progress and development on power dc-dc converter topology,control,design and applications: a review", *Renewable and sustainable energy review*,vol.81,part 1,pp.205-230, January 2018.
- [2] Babaei. E,SeyedMahmoodieh M.E and MashinchiMahery H, "Operation modes and output-voltage-ripple analysis and design consideration of buck-boost dc-dc converters" *in IEEE Transactions on Industrial Electronics*,vol.59,no.1,pp 381-391,January 2012.
- [3] JN Rai, Nikhil Gupta, Prashant Bansal, " Design and analysis of dc-dc converter " ,*International journal of advance research and innovation*, vol-04,issue 3,PP:499-502, 2016.
- [4] Wuhua Li, XiaodongLv, Yan Deng, Jun Liu, Xiangning He, "A review of non-isolated high step up dc/dc converters in renewable energy applications"*IEEE Transaction on Industrial Electronics*,vol.58,no.4,pp.1239-1250,Apr.2011.
- [5] Rodrigo Loera-palomo and Jorge Alberto Morales-Saldna, "Family of quadratic step-up dc-dc converters based on non-cascading structures," *in IET power electron*.vol.8,issue.5,pp.793-801,2015.
- [6] Forouzesh M.,Siwakoti Y.P, Gorji S. A.,Blaabjerg F and Lehman B, " A survey on voltage boosting techniques for step-up dc-dc converters," *IEEE Energy Conversion Congress and Exposition (ECCE)*, Milwaukee, WI, pp.1-8,2016.
- [7] Shafinaz A.Lopa, Hossain S, Hasan M.K, Chakraborty T.K , " Design and simulation dc-dc converter", *International research journal of engineering and technology (IRJET)*,vol-03, issue:01 ,PP:63-70, 2016.
- [8] Sunil kumar Jain, Dr. Manish kumar srivastava , " A study of step- up dc-dc converter for renewable energy systems using pspice", *International journal of creative research thought (IJCRT)*,Vol-6,issue 1,pp:427-431, 2018.
- [9] Divya Navamani J, Jason mano raj, Vijayakumar, Lavanya K , "Anaysis of modified quadratic dc-dc boost converter" , *International conference on initiative system and control (ICISC)*,PP:1-5,2017.
- [10] Siddhant kumar, Adil usman, " Effective design and analysis of a dc-dc boost converter with experimental validation", *International conference on computation of power,energy,information,communication. (ICCPPEIC)*,PP:261-268, 2018.