



# INTERNATIONAL JOURNAL OF CREATIVE RESEARCH THOUGHTS (IJCRT)

An International Open Access, Peer-reviewed, Refereed Journal

## ELEVATING THE PERFORMANCE OF GRID-CONNECTED PHOTOVOLTAIC (PV) SYSTEM USING MULTILEVEL INVERTER

Miss. Nidhi G. Sharma  
MGITER, NAVSARI- 396445 GUJARAT  
[sharmanidhi.1999.nd@gmail.com](mailto:sharmanidhi.1999.nd@gmail.com)

Prof. Gaurang C. Patel  
Assistant Professor  
MGITER, NAVSARI- 396445 GUJARAT

Mr. Hemant J. Patel  
MGITER, NAVSARI- 396445 GUJARAT  
[patel.hemant81@gmail.com](mailto:patel.hemant81@gmail.com)

**Abstract—** Demand for renewable energy sources has increased due to the limited nature of fossil fuel reserves, which lead to carbon emissions into the atmosphere. Presently, solar and wind power stand out as the most widely adopted renewable energy options for integration into the power grid. Solar energy, specifically harnessed through photovoltaic systems, has become increasingly affordable and is characterized by its cleanliness and lack of pollution. Consequently, photovoltaic power generation has garnered significant attention, particularly in developing nations. Within the realm of photovoltaic energy systems, there exist two primary categories: grid-connected systems and stand-alone systems. Among these, grid-connected photovoltaic systems offer an effective means to incorporate solar energy into the existing electrical grid infrastructure. A pivotal component within these grid-connected photovoltaic systems is the inverter, which can exert a substantial influence on the system's overall performance. This influence extends to factors such as total harmonic Distortion (THD) and efficiency. Over the past decade, the concept of multilevel inverters has gained popularity in the field of renewable energy applications. In the context of this dissertation, various topologies of grid-tied Photovoltaic systems are thoroughly examined to demonstrate the potential of such systems. Additionally, the dissertation attempts to conduct simulations of grid-connected photovoltaic systems, incorporating Maximum Power Point Tracking (MPPT) techniques in conjunction with multilevel inverters, using MATLAB/SIMULINK software.

**Keywords-** Maximum Power Point Tracking (MPPT) techniques, Multilevel Inverter, Three phase three level CHB ,grid connected pv system.

### I. INTRODUCTION

#### Importance of Renewable Energy System

The demand for renewable energy systems is growing day by day because of continuous in-crease in energy demand, increase of global economy, rapid industrialization and population growth. In addition, the effects of fossil fuel energy sources like world climate changes (greenhouse gas emissions),

which may leads to serious health issues of humans. The early day challenges like, uncertainty and high initial installation cost are limiting the efficient uti-lization of all renewable energy sources.

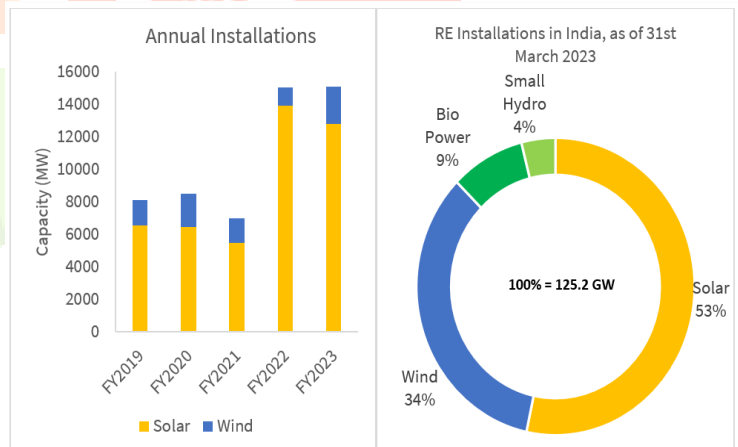

Fig. 1 Renewable power capacity growth rate , 2019-2023

The tremendous growth in harvesting technology, easy installation, reduced costs ,low environmental impact, and recent developments in semi-conductor fabrication technology has considerably reduced the initial cost and brought the renewable energy sources back to focus. The power capacity growth rate of renewable power capacity from 2019 to 2023 is shown in Fig.1 [2].The renewable energy sector added 125.2 GW of generating capacity nationally during 2019-2023.

New renewable energy capacity as a percentage of installed capacity almost doubled compared to last year, according to data released by the International Renewable Energy Association. The total installed PV capacity in the world could reach 1177 GW by 2023, according to the most recent data from Statista.com.

II. GRID- CONNECTED PHOTOVOLTAIC SYSTEM

Grid connected photovoltaic (PV) power conversion systems are getting more and more at-tention in the last decade, mainly due to cost reduction of PV modules and government incentives, which has made this energy source and technology competitive among other energy sources.

In an isolated system, the solar electricity capacity is not enough to supply the load in bad weather conditions. The excess power produced by an isolated solar system is a loss on summer days. When we connect solar energy to the grid, the quality of electricity in the system is negatively affected. Traditional inverters have poor power quality. Low efficiency of PV in grid inverter.

So, using MLI to enhance the overall performance and power quality of the PV system.

cascaded H- bridge inverter etc. for the basic understanding refer[13].

Cascaded H-Bridge Multilevel Inverter

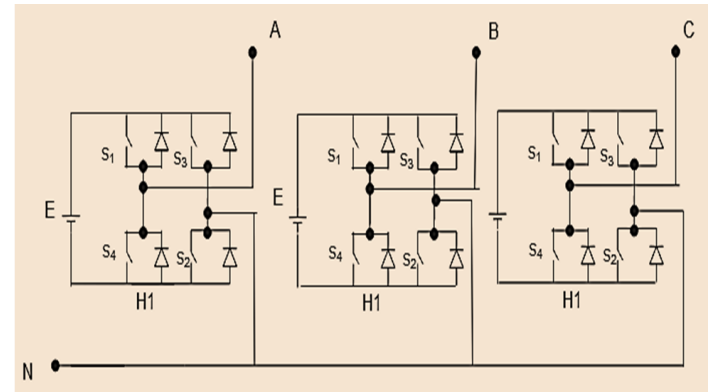

Fig.4 Three Phase Three Level Cascaded H bridge MLI

The CHB has many cells connected in series. The dc link of each cell is isolated. Each cell produce three level of different voltages : 0,+Vdc,-Vdc. Number of Switch Required : 2(L-1).

Now we have comparison between conventional inverter and multilevel inverter shown below Table 1.

Table.1 Comparison between conventional inverter and multilevel inverter

Factor under Consideration	Two Level Inverter	MLI
Switching loss	High	Low
dv/dt and EMI	High	Low
Voltage stress on switches	More	Less
Switching frequency	High	Low
Levels of voltage in output	Two	More then Two
Harmonics	More	Less

Maximum Power Point Tracking Method(MPPT)

The main advantage of this method is the simplicity and accuracy of the algorithm, so it can be calculated accurately even with an inexpensive microcontroller. The main idea of this modified P&O is to add a control algorithm to the modified P&O MPPT.

We have depicted an easily understandable and executable algorithm for Perturb & Observe method above in figure 5.

III. BLOCK DIAGRAM OF PROPOSED SCHEME

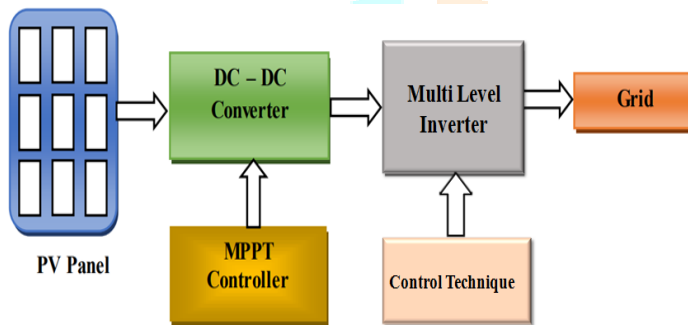

Fig. 2 Block Diagram Of Proposed Scheme

Importance of Power Electronic Converter For Renewable Energy System

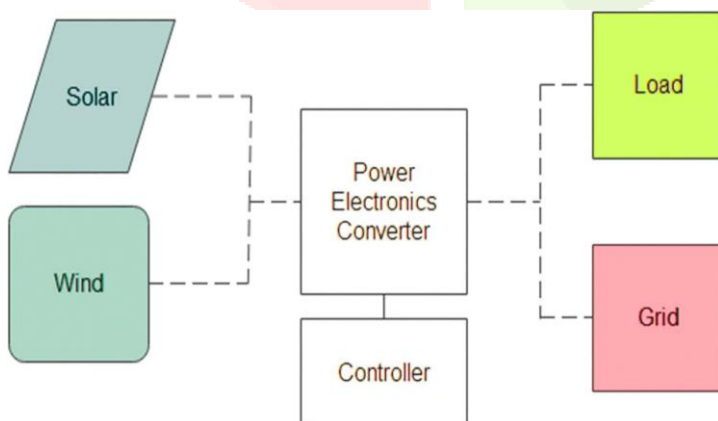

Fig.3 The power electronic converter as an interface between the renewable energy source and the load/grid.

In this paper, a comparative study of multilevel inverters is executed, Some topologies of inverters have been studied: two-level inverters, Neutral-Point clamped inverter types and

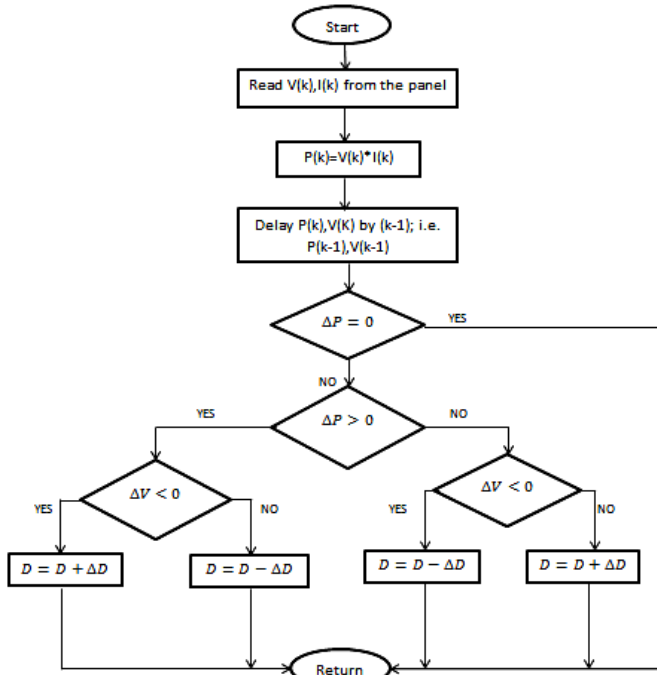

Fig. 5 Algorithm of P&O Method

IV. SIMULATION AND RESULTS

PV Module Simulation

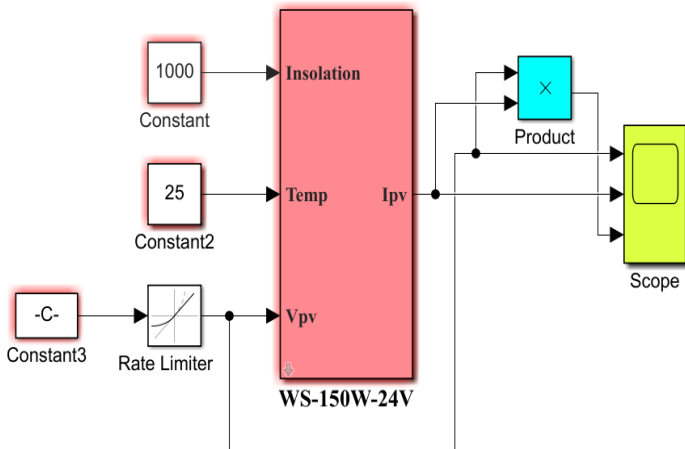

Fig.6. Ten module connected in series

Basic simulation of PV module is shown in the figure 6 above. Ten modules are connected here in series with each other. We simulated the system with single module first, and then we are now simulating the system with ten modules.

Table 2 Parameter and value of PV Cell

PARAMETER	VALUE
Nominal Maximum Power(Pm) in Watt	150 Watt
Open circuit Voltage (V <sub>oc</sub> )	44.30 Volt
Short circuit current (I <sub>sc</sub> )	4.51 Amp
Voltage at Maximum Power (Vmp)	36.10 Volt
Current at Maximum Power (Imp)	4.16 Amp
Number of Module connected in series	10
Number of Parallel Cell	1
Number of series Cell	72

The parameters for our simulation are tabulated above in table 2. With 10 module connected in series, we get output power 1500 watt and current 4.51 Amp.

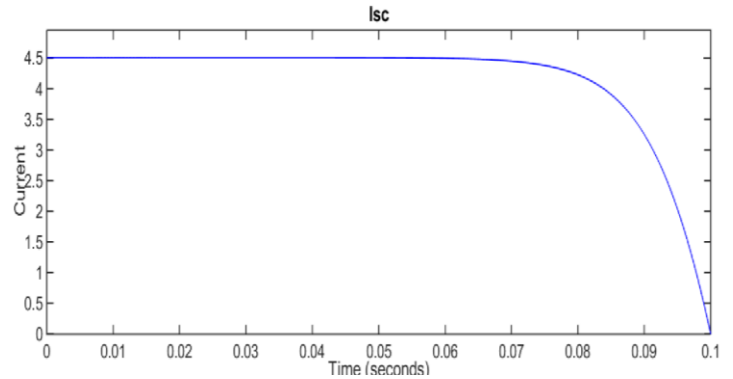

Fig.7 Output waveform of IV curve

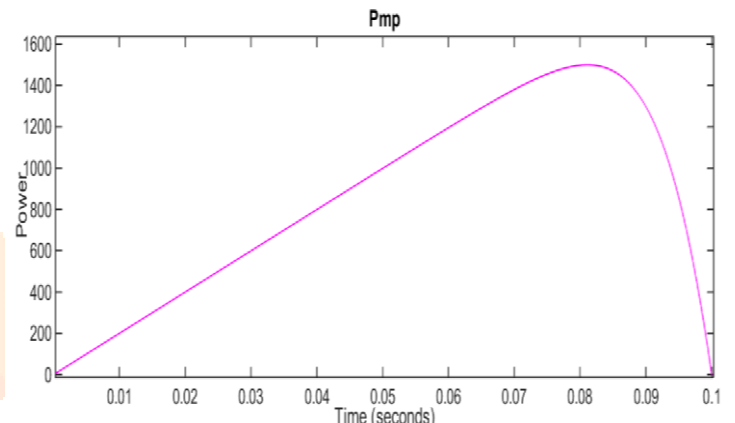

Fig.8 Output waveform of PV curve

As per the graphs shown in the figure 7 above, we can observe that the output power is 1500 watt and current is 4.51 Amp. It is seen that the PV curve reaches up to 1500 W and IV curve reaches up to approximately 4.51 A.

P&O MPPT

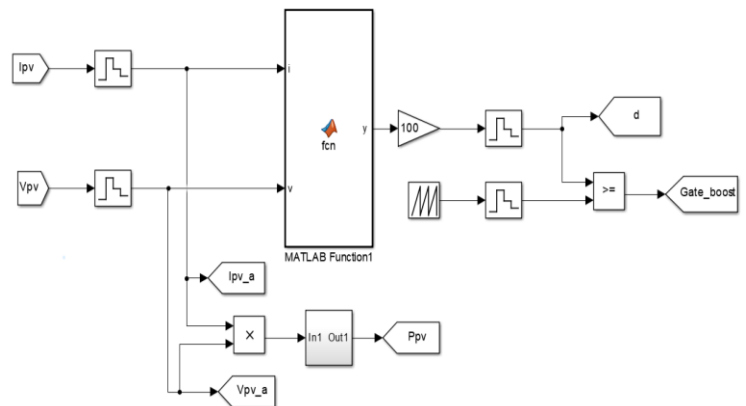

Fig.9 P & O for Boost Converter

Figure.9 presents the Simulink Model of Perturb and Observe Method for Boost Converter.

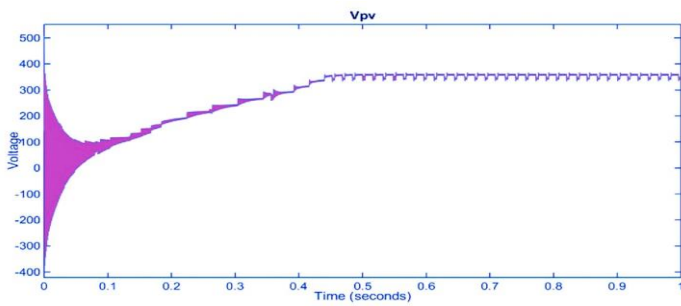

Fig.10 Output waveform of PV voltage

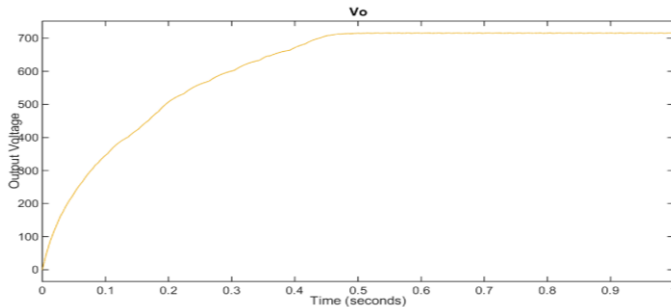

Fig. 11 Output Voltage of Boost Converter

The results from the Simulation of PV module using P&O method with Boost Converter are depicted in the figure 9 here. We can observe that the output of PV module was 361 V without connecting the MPPT system to it.

After the using of MPPT system with the PV module, we could succeed in boosting the output voltage to be around 722 V. This clearly shows that the MPPT system can improve the overall efficiency of the grid-connected PV system.

**Model of mppt using p&o Method**

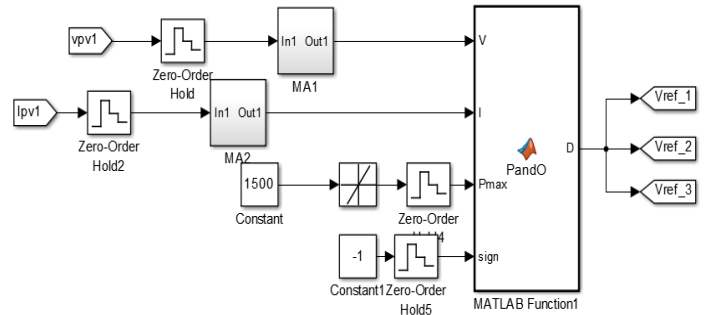

Fig.14 MPPT using P & O algorithm

**Voltage Controller**

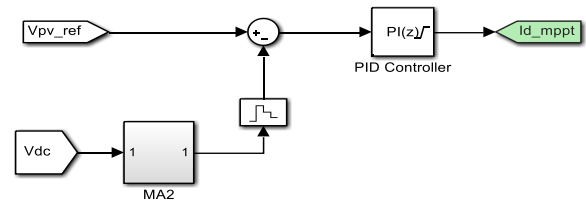

Fig.15 Model of Voltage Controller

**V. SIMULATION OF PV BASED GRID CONNECTED CHB MULTILEVEL INVERTER**

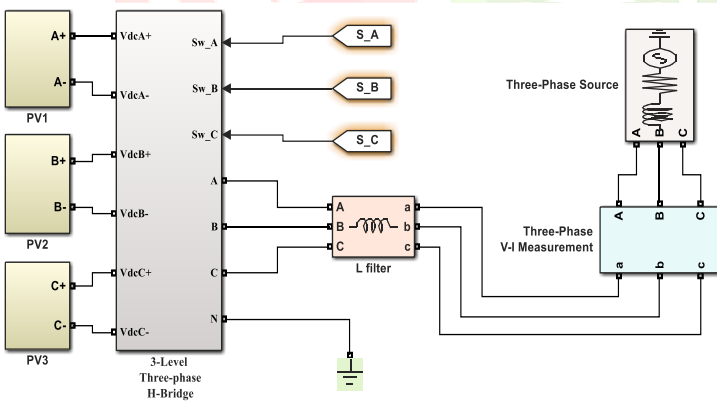

Fig.12 Simulation model of PV based grid connected CHB MLI

Sub-System of PV cell shown in fig.13

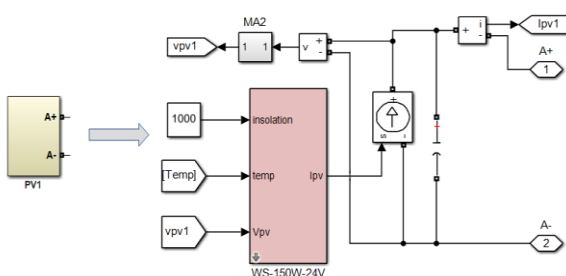
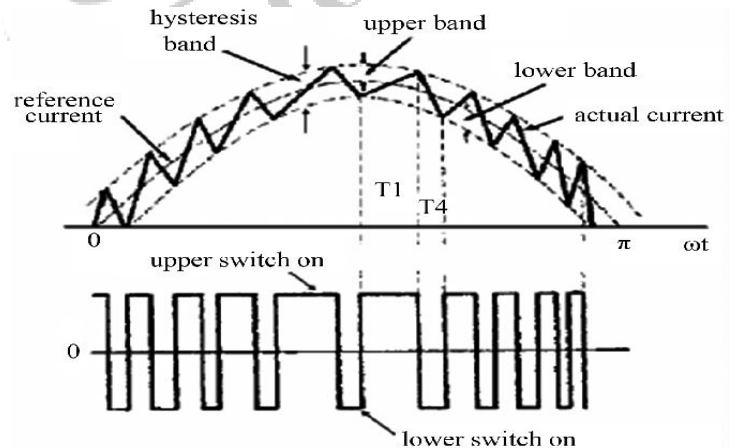

Fig.13 Sub-System of PV cell

**Hysteresis Current Controller**

The HCC is a technique which can be used to control inverter. To produce switching pulses for the inverter.



Hysteresis current controllers(HCCs) are among the many methods that provide resilience against variations in the output load parameter, fast dynamic response, and ease of implementation.

A variety of HCC strategies for grid-connected systems have been presented in [16]. Sliding mode controllers (SMC) and other non-linear controllers can reduce chattering by using HCC techniques [17].

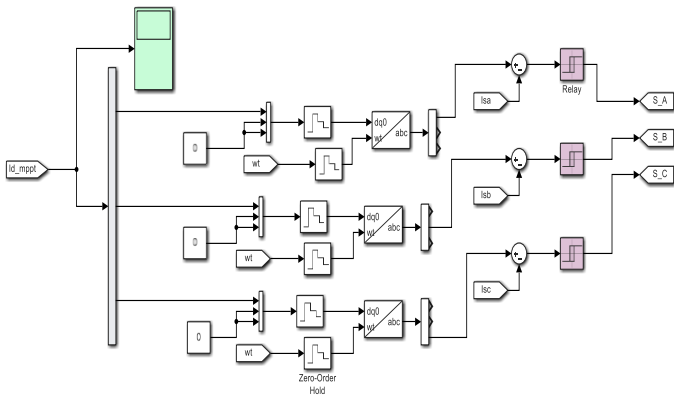

Fig.16 Hysteresis current Controller

**Waveform Of Hysteresis Current Controller**

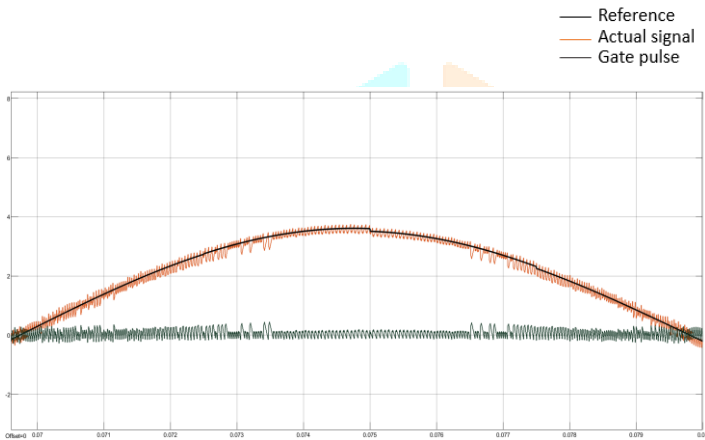

Fig.17 Hysteresis current Controller

**Dc Link Voltage Waveform**

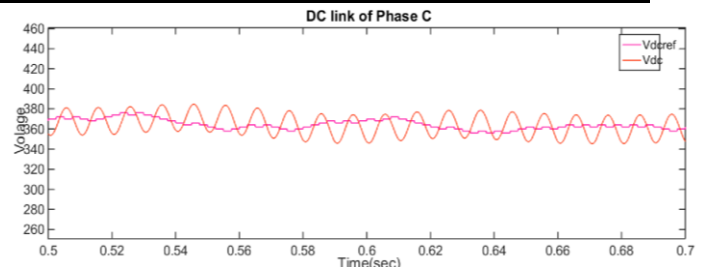
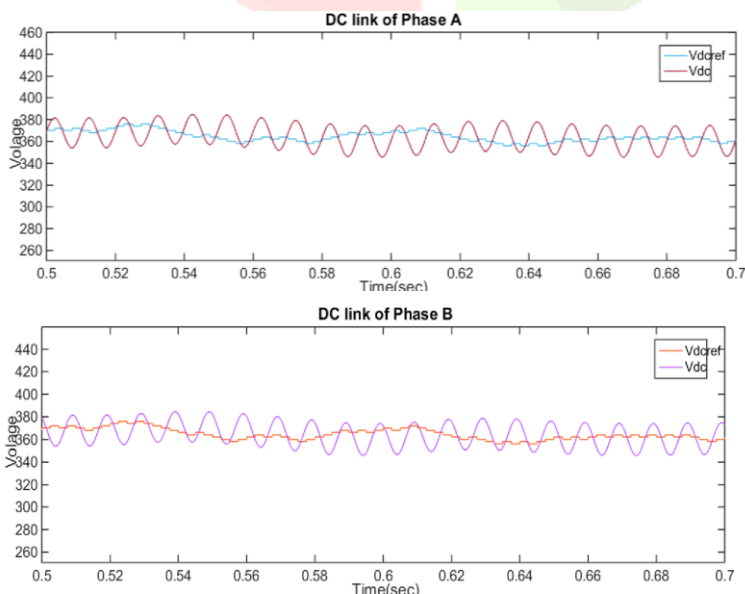

Fig.18 DC link voltage of (a) Phase A (b) Phase B (c) Phase C

Here, each H-bridge's linked PV panel is independent of the panels connected to other H-bridges and can run at its own MPP voltage. As a result, more solar energy may be captured, increasing the PV system's total efficiency.

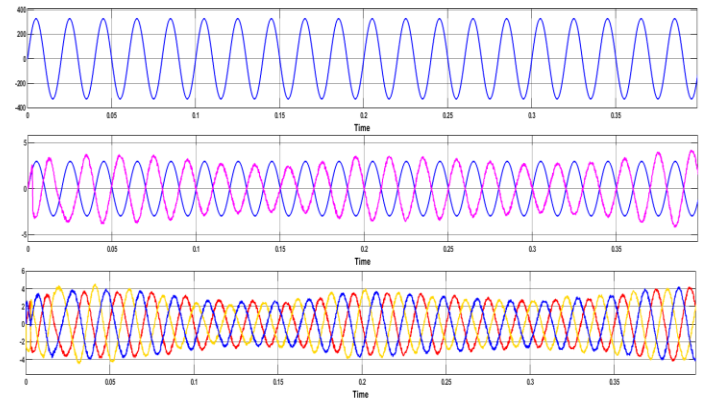

Fig. 19 Three Phase Waveform (a) Voltage (b) Voltage & Grid inject Current (c) Grid Current

The output waveform of three phase three level H-bridge grid connected multi-level inverter shown in fig. 19. There is some out phase of the current waveform that indicates the current injected in grid.

Power injected per phase is 1500 watt, so in three phase system approximate 4480 watt power injected to grid, which is shown in fig.20

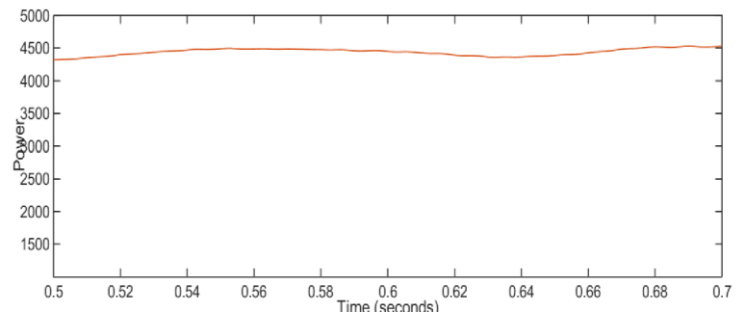

Fig.20 Power injected into grid

## THD Analysis Of Grid Current

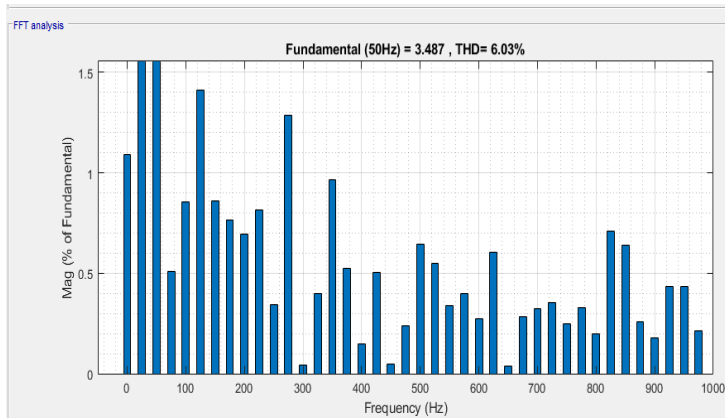

Fig.21 THD Analysis Of Grid Current

The grid current has a power factor of one and the same phase as the grid voltage. As seen in Fig.21 the grid current's THD is 6.03%, which is near about 5% and satisfies power quality requirements.

## VI. CONCLUSION

This research presents a cascaded H-bridge multilevel inverter designed for grid-connected photovoltaic applications. If the voltages of the various DC links are managed separately, the multilevel inverter topology will aid in increasing the utilisation of linked PV modules. In order to boost the overall efficiency of PV systems, an Individual MPPT control method has been implemented for three-phase PV systems.

## REFERENCES

- [1] Mahesh Kumar, "Technical Issues and Performance Analysis for Grid Connected PV System and Present Solar Power Scenario" 2020, International Conference on Electrical and Electronics Engineering (ICEE-2020).
- [2] Xueyang Jiang, Mamadou Lamine Doumbia "Comparative Study of Grid-Connected Multilevel Inverters for High Power Photovoltaic Systems" 2019 the 7th International Conference on Smart Energy Grid Engineering.
- [3] Mustafa Abu-Zaher, Yousry Atia, Farag K. Abo-Elyousr "Experimental Realization for P&O Maximum Power Point Tracking Applied for Single-Stage Three-Phase Grid-Connected Photovoltaic System" 2019 21st International Middle East Power Systems Conference (MEPCON), Tanta University, Egypt.
- [4] Kunal Makarand Pisolkar, Vivek Kore "Solar PV grid connected system using Phase Lock Loop Synchronization and SPWM technique" 2019 2nd International Conference on Intelligent Computing, Instrumentation and Control Technologies (ICICT)
- [5] N. Kannan and D. Vakeesan, "Solar energy for future world:-A review," Renewable and Sustainable Energy Reviews, vol. 62, pp. 1092-1105, 2016. D. K. Sambariya, R. Gupta, and A. K. Sharma, "Fuzzy Applications to Single Machine Power System Stabilizers", journal of theoretical and applied information technology, 2005-09, www.jatit.org

- [6] Benaissa Mohammed Omar, Hadjeri Samir, Zidi Sid Ahmed, Djilani Kobibi Youcef Islam "A Comparative Investigation of maximum Power Point Tracking Techniques for Grid Connected PV System under Various weather Conditions." The 5th International Conference on Electrical Engineering – Boumerdes (ICEE-B) October 29-31, 2017, Boumerdes, Algeria.
- [7] Gayathri Devi B., M. Mahesh "A Brief Survey on Different Multilevel Inverter Topologies for Grid-Tied Solar Photo Voltaic System" 2017 the 5th IEEE International Conference on Smart Energy Grid Engineering.
- [8] Akel Fethi , Bendib douadi, Mohammed Laour, Berkouk El-madjid "Power Control of Three Phase Single Stage Grid Connected Photovoltaic System" 2016 IEEE.
- [9] Dr. Sachin S. Bharatk, Mr. Raju R. Bhoyar, Mr. Sarang A. Khadtare "Analysis of three phase cascaded H-bridge multilevel inverter for symmetrical & asymmetrical configuration." IEEE-2014.
- [10] Tsai-Fu Wu, Chih-Hao Chang, Chia-Ling Kuo "Power Loss Comparison of Single- and Two-Stage Grid-Connected Photovoltaic System." IEEE TRANSACTIONS ON ENERGY CONVERSION, VOL. 26, NO. 2, JUNE 2011.
- [11] Amrithesh Kumar and Vishal Verma, Member, IEEE "Performance Enhancement of Single Phase Grid Connected PV System under Partial Shading using Cascaded Multilevel Converter ", 2018 IEEE Transactions on Industry Applications.
- [12] Abderezak Lashab , Student Member, IEEE, Dezso Sera , Senior Member, IEEE, Frederik Hahn , Student Member, IEEE, Luis Camarca, Student Member, IEEE "Cascaded Multilevel PV Inverter With Improved Harmonic Performance During Power Imbalance Between Power Cells" IEEE TRANSACTIONS ON INDUSTRY APPLICATIONS, VOL. 56, NO. 3, MAY/JUNE 2020.
- [13] RashaKamel El Tantawy, ShawkyHamedArafah, Salah Ghazy Ramadan "Single-Stage PV grid-connected system with three level diode clamped inverter and Hysteresis current controller" International Journal of Scientific & Engineering Research Volume 8, Issue 5, May-2017
- [14] J Sreedevi , Ashwin N, M Naini Raju "A Study on Grid Connected PV system "2016 IEEE
- [15] Serkan Sezen, Ahmet Aktas, Mehmet Ucar, Engin Ozdemir "A Three-Phase Three-Level NPC Inverter Based Grid-Connected Photovoltaic System With Active Power Filtering" 2014 16th International Power Electronics and Motion Control Conference and Exposition.
- [16] S. Jena, B. Mohapatra and C. K. Panigrahi, "Realization of double band hysteresis current controller for single phase grid connected pulse width modulated voltage source inverter," 2015 International Conference on Man and Machine Interfacing (MAMI), Bhubaneswar, 2015, pp. 1-6.
- [17] H. Komurcugil, S. Bayhan and H. Abu-Rub, "Variable- and Fixed-Switching-Frequency-Based HCC Methods for Grid-Connected VSI With Active Damping and Zero Steady-State Error," in IEEE Transactions on Industrial Electronics, vol. 64, no. 9, pp. 7009-7018, Sept. 2017.
- [18] Nikos E. Mastorakis and Manisha dube, " Design of Fuzzy Logic Power System Stabilizers in Multimachine Power System using Genetic", WSEAS Transactions on Systems and Control, ISSN: 1991-8763, ISSN: 1991-8763
- [19] Wenxin Lui, Ganesh K.Venayagamoorthy, Donald C.Wunsch, " Adaptive Neural Network Based Power System Stabilizer Design", 0-7803-7898-9/03/\$17.00 ©2003 IEEE.
- [20] S. A. Taher and A. Shemshadi, " Design of Robust Fuzzy Logic Power System Stabilizer", World Academy of Science, Engineering and Technology 27, 2007
- [21] Indraneel Sen and Anup Singh, " A Novel Fuzzy Logic Based Power System Stabilizer for a Multimachine System", 0-7803-7898-9/03/\$17.00, TENCON ©2003 IEEE.
- [22] Abhisek Ukil, "Intelligents System and Signal Processing in Power Engineering".
- [23] Manpreet Joshi and Ms. Suman Bhullar, " Comparative Analysis of Power System Stabilizer under small scale stability considerations using conventional, Neural Network and Fuzzy Logic Based Controllers", Electrical & Instrumentation Engineering Department, Thapar University, Patiala.

## BIOGRAPHIES



Miss NIDHI G . SHARMA has received the B.E degree in Electrical Engineering from Gujarat Technological University, Chandkheda, Ahmedabad Gujarat in 2020. Currently she studies in M.E(electrical engineering) in Mahatma Gandhi Institute of Technical Education & Research centre, Navsari under Gujarat Technological University, Chandkheda, Ahmedabad Gujarat



Prof. Gaurangkumar C. Patel has received the B.E. degree in Electrical Engineering from H.N.G.UNIVESITY Patan, Mehsana, Gujarat in 2008 and ME (Electrical Engineering) in 2012 and PhD Pursuing from Gujarat Technological University. Currently he is working as Assistant Professor at Mahatma Gandhi Institute of Technical Education and Research Centre. Navsari under Gujarat Technological University Chandkheda ,Ahmedabad Gujarat.



Mr. HEMANT J. PATEL has received the B.E degree in Electrical Engineering from Sardar Patel University, V.V.Nagar, Anand, Gujarat in 2003. Currently he studies in M.E(electrical engineering) in Mahatma Gandhi Institute of Technical Education & Research centre, Navsari under Gujarat Technological University, Chandkheda, Ahmedabad Gujarat.