



# INTERNATIONAL JOURNAL OF CREATIVE RESEARCH THOUGHTS (IJCRT)

An International Open Access, Peer-reviewed, Refereed Journal

## SUSPICIOUS ACTIVITY MONITORING SYSTEM USING MACHINE LEARNING

M.ishvarya

Kalasalingam academy of research and education  
Computer science and engineering  
Assistant professor

D. Ashok reddy

Kalasalingam academy of research and education  
Computer science and engineering

B.Lakshmi shreya

Kalasalingam academy of research and education  
Computer science and engineering

P.v.venkata rama krishna reddy  
Kalasalingam academy of research and education  
Computer science and engineering

K.ragu ramvel pandian  
Kalasalingam academy of research and education  
Computer science and engineering

**Abstract:** In the present advanced world, compelling reconnaissance and oddity identification frameworks are a higher priority than any time in recent memory. This article strolls you through the most common way of carrying out the YOLOv5 calculation for recognizing dubious movement in photographs and recordings. The accuracy and speed of YOLOv5, a state of the art continuous article recognizable proof model, have made it a famous choice for such applications. The main part of the instructional exercise goes over the essential libraries and conditions for this undertaking, which incorporate anything from information handling apparatuses to YOLOv5 execution libraries.

**Index Terms** – Suspicious Activity, YOLOV5, Exploratory Data Analysis (EDA)

### 1. INTRODUCTION

The need for effective surveillance and abnormality discovery frameworks has never been more prominent in the present rapidly extending advanced environment. Guaranteeing the wellbeing and security of both physical and virtual spots has turned into a main concern, and state of the art innovations are at the very front of handling these troubles. This itemized instructional exercise strolls you through the most common way of carrying out the YOLOv5 calculation, a state of the art answer for constant article acknowledgment, with regards to identifying dubious movement in photographs and recordings. YOLOv5 has gotten overall acknowledgment and appreciation for its unprecedented blend of accuracy and speed, making it an incredible choice for an expansive scope of utilizations, strikingly security and surveillance. This instructional exercise is planned to furnish you with the data and assets you really want to completely understand the capability of YOLOv5, from setting up the proper climate to preparing a tweaked model that can recognize and signal dubious action. The outing

begins with establishing the groundwork, as we research the vital libraries and conditions for this task. This is the most vital phase in guaranteeing a smooth work process all through the execution cycle. We'll take a gander at information control devices and YOLOv5-explicit libraries to get a feeling of what's to come. Continuing on, the book focuses on the significant issue of bringing in datasets, focusing on the YOLO [27] comment design. Appropriately planning and arranging the dataset is basic in the preparation cycle, and this post gives supportive tips on the most proficient method to do as such. In the third section, we will take a gander at exploratory data analysis (EDA) as it connects with YOLOv5. Imagining model pictures utilizing bouncing boxes, computing class dispersion, and assessing picture size and goal are basic to ensuring great and legitimate explanations, making the preparation for an effective model. Most of this article is given to applying the YOLOv5 calculation to your dataset. Stacking the YOLOv5 model, preparing it on your meticulously pre-arranged information, or tweaking a pre-prepared model to meet your one of a kind points are instances of this. The guide will likewise go over how to assess model execution utilizing legitimate measurements, which will assist you with evaluating the progress of your abnormality discovery framework. At long last, we examine the pragmatic uses of the prepared YOLOv5 model in both constant and bunch handling settings, exhibiting its abilities in recognizing and hailing dubious activities. This book is a valuable asset for people hoping to apply YOLOv5 with regards to security, observation, or comparable use cases, permitting the development and execution of a far reaching object location framework that further develops wellbeing and security in an undeniably confounded computerized climate.

## 2. LITERATURE REVIEW

They depict [1] a video-based system for vigorous Strange Occasion Acknowledgment at ATM establishments, determined to further develop client security. The framework utilizes principal component analysis and support vector machines for highlight extraction, dimensionality decrease, and grouping, accomplishing an exceptional typical accuracy of 95.73% by utilizing motion history image (MHI) and Hu minutes. With a high accuracy of 95.73%, their proposed system effectively recognizes distorted ATM movement, for

example, cash taking or purchaser injury. The innovation, which consolidates movement and structure investigation, offers a reliable choice for expanding security and answering rapidly to upsetting circumstances at ATM establishments. Potential disadvantages incorporate misleading cautions brought about by harmless activities, which could imperil framework constancy. Outside factors, for example, lighting conditions and camera points may likewise affect the exactness of strange occasion discovery, bringing down in general execution. Tending to misleading problems, changing the framework for changing lighting conditions, and creating grouping calculations to deal with various conditions are troublesome assignments. Giving constant reaction and adjusting to changed ATM settings are basic difficulties to defeat for fruitful organization. The precision of the recommended technique might change in troublesome lighting conditions or at odd camera points. It might neglect to represent surprising criminal procedures or quick creating assault techniques, underlining the need of continuous refining to keep awake with developing security concerns.

[2] Utilizing RGB+D sensors and multi-stream CNNs, we portray an ongoing observation framework for bank ATMs. With an precision of 0.932 and a accuracy of 94.2%, movement layouts created from RGB and profundity information permit online ID of dubious events, showing its convenience. Our RGB+D sensor-based deep learning framework identifies dubious exercises in bank ATMs progressively. The proposed technique is effective in further developing security and observation measures, with an precision of 0.932 and an accuracy of 94.2%. While the framework is useful, it might experience troubles in genuine execution, like conceivable bogus up-sides, the prerequisite for persistent sensor adjustment, and higher registering needs for handling RGB+D information streams continuously. Addressing false positives, guaranteeing reliable sensor adjustment, and controlling the figuring trouble engaged with handling constant RGB+D information are all execution issues that hinder smooth sending in practical observation applications. The proposed strategy depends on a regulated profound learning procedure, which might require a lot of marked information for preparing. Besides, it might experience imperatives in convoluted

circumstances and different natural conditions, requesting further refining and adaption for more extensive use.

[4] Utilizing the WISDM dataset, our framework utilizes CNN and LSTM for Human Activity Recognition (HAR). This procedure further develops expectation exactness by consolidating the advantages of the two plans, making it helpful for applications in eldercare, childcare, medical care, wellness, gaming, military, and security areas. Our proposed framework gives solid HAR by blending CNN and LSTM, demonstrating its versatility across a few spaces. When applied to the WISDM dataset, the technique produces exact expectations, exhibiting its true capacity for certifiable applications in medical services, wellness, security, and different fields. Potential impediments incorporate computational intricacy because of CNN and LSTM combination, which requires a lot of figuring power. Besides, reliance on sensor information might limit variation to fluctuated certifiable settings, requiring thorough model change for most extreme execution. Improving model boundaries for different exercises, controlling figuring needs, and managing conceivable commotion in sensor information are difficulties. Guaranteeing vigorous execution across numerous clients and settings is an issue that requires cautious consideration in framework plan. Regardless of its viability, the recommended framework might have limits in managing undetected activities or novel client ways of behaving that are not all around addressed in the preparation information. For broad execution, aversion to contrasts in sensor information quality and potential predispositions in the WISDM dataset ought to be thought of.

[5] In video observation, we offer a CNN-based model for ongoing Human Suspicious Activity Detection. It computerizes irregularity location in CCTV video utilizing AI calculations, conveying quick admonitions for brief reaction. The methodology has been confirmed on a dataset, with improved brings about separating among ordinary and obsessive action. The recommended CNN-based strategy for Human Suspicious Activity Detection in Video Surveillance mechanizes oddity identification. It gives a commonsense way to deal with helping wellbeing by means of constant checking and quick caution creation, with empowering results on an

expansive dataset. Potential drawbacks incorporate bogus up-sides, which happen when the framework misidentifies ordinary movement as dubious, and false negatives, which happen when the framework misses genuine anomalies. The reliance on previous data might limit adaptability to surprising conditions, and consistent model preparation might be expected to stay aware of creating danger environments. The model should be adjusted to lessen bogus admonitions, handle contrasts in brightening and camera sees, and guarantee continuous handling speed. Reconciliation into current checking framework and settling protection issues are two further impediments to more extensive use. While fruitful, the recommended approach might have limits in distinguishing unobtrusive irregularities or acclimating to changing danger strategies. The reliance on past information patterns might restrict its ability to distinguish creative or already obscure dubious activities, underlining the need of continuous model updates and enhancements.

[6] We give an interesting method to distinguishing bizarre human activities that resolves the issue of restricted datasets. Our strategy utilizes a ConvLSTM brain network that was prepared and tried on a newly created dataset with different irregular activities. Our method outperforms elective plans, accomplishing an extraordinary 96.19% accuracy and 96.50% precision. Our ConvLSTM-based framework succeeds in distinguishing strange human way of behaving, as shown by its exhibition on an enormous dataset. Its exceptional accuracy and precision of 96.19% and 96.50% make it helpful for further developing security and reconnaissance applications in genuine settings. Overfitting to the specific bizarre activities remembered for the delivered dataset is one of the expected drawbacks. The reliance on ConvLSTM might bring about expanding processing requests, and the requirement for enormous scope named datasets stays a hindrance to far reaching use. The hardships incorporate guaranteeing that the model is generalizable to many distorted activities, overseeing figuring assets for constant handling, and settling any inclinations presented during dataset advancement. Unexpected issues emerge while calibrating the model for adaptability and strength. While the proposed framework accomplishes extraordinary exactness, it might have limits in answering unexpected odd activities not addressed in the

dataset. The exhibition of the design might differ in confounded genuine conditions, underlining the need for progressing advancement and development of the dataset.

### 3. METHODOLOGY

Deep learning is presently being utilized broadly in man-made brainpower object recognizable proof, which is the most common way of identifying and finding things in advanced pictures or films. Deep learning neural networks [20] for object acknowledgment are prepared on gigantic datasets of explained photos, where the calculations figure out how to distinguish things by extricating data from the pictures like edges, corners, surfaces, and varieties. These attributes are then used to foresee the presence and area of things in recently seen pictures.

#### Drawbacks:

- Deep learning for object ID requires colossal named datasets, making it unsatisfactory for regions with negligible information.
- Deep network preparing requires critical processing assets, which may be exorbitant and inaccessible to specific clients.
- Deep learning models are many times dark, going with it hard to get a handle on their choice making processes.
- Adjusting pre-prepared models to new object ID undertakings might be hard and tedious, requiring space explicit information.

The proposed framework utilizes the YOLOv5 calculation for successful picture and video reconnaissance and abnormality recognizable proof. Setting up the fitting framework, bringing in datasets in Consequences be damned arrangement, doing exploratory information examination, and preparing the model are all important for the cycle. Utilizing a state of the art model, this methodology gives dependable recognizable proof of dubious ways of behaving. The framework's applications cover security, observation, and different fields, giving a full answer for planning and carrying out a hearty item discovery framework that is both exact and quick.

#### Benefits:

- Due to its speed and accuracy, YOLOv5 is ideally suited for constant observing, taking into account the prompt recognizable proof of irregularities and potential dangers.
- Straightforward climate arrangement and dataset import lessen organization time and asset needs.
- Viable peculiarity discovery further develops security by lessening phony problems and further developing asset distribution.
- Flexible applications go past security, giving a vigorous answer for some areas looking for exactness in object recognition errands.

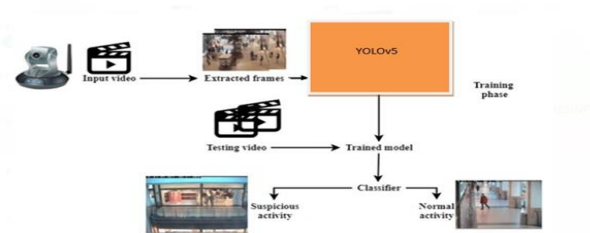

Fig 1 System Architecture

#### MODULES:

We planned the modules showed beneath to do the previously mentioned project.

- Information investigation: we will include information into the framework utilizing this module;
- Handling: we will peruse information for handling utilizing this module.
- Information parting into train and test: Utilizing this module, information will be parted into train and test.
- Model generation: Model building - YOLOv5
- Client enlistment and login: Utilizing this module will bring about enrollment and login.
- Client input: Utilizing this module will give prescient information.
- Forecast: the last expected esteem is introduced.

**Note:** As an addition, we used an ensemble approach to combine the predictions of numerous independent models, resulting in a more robust and accurate final forecast.

However, we may improve the performance even more by investigating different ensemble strategies, such as YOLOv5, which has the highest accuracy.

#### 4. IMPLEMENTATION

The accompanying algorithms were used in this exploration.

##### YOLOv5:

YOLOv5 (You Only Look Once version 5) is a computer vision object identification system that everything in real time. It is familiar for allure speed and veracity in detecting and judgment abundant articles in pictures or television frames. The YOLOv5 deep learning model is engaged for exercises to a degree independent forceful, following, and figure study.

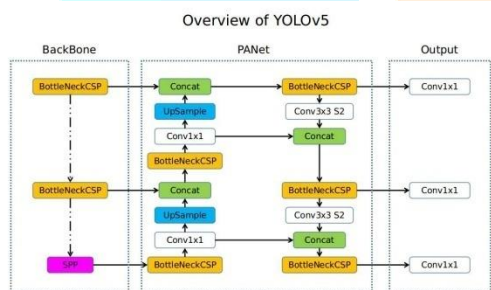

Fig 2 Overview Of YOLOV5

**YOLOv5 Architecture:** The following is a summary of the YOLOv5 architecture:

##### 1. Backbone Network:

To extract hierarchical information from an input picture, YOLOv5 commonly use a backbone network. CSPDarknet53 and CSPResNext50 are two popular options.

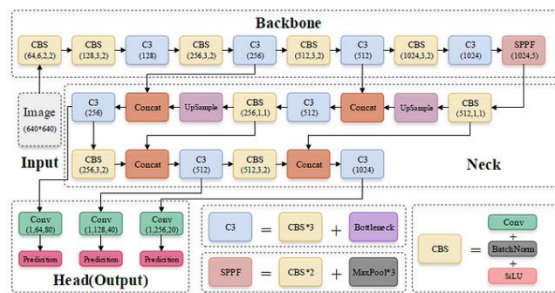

Fig 3 YOLOV5 Backbone

##### 2. Neck:

The YOLOv5 neck links the backbone to the detecting head and is in charge of feature fusion. PANet (Path Aggregation Network) is a popular network for this purpose.

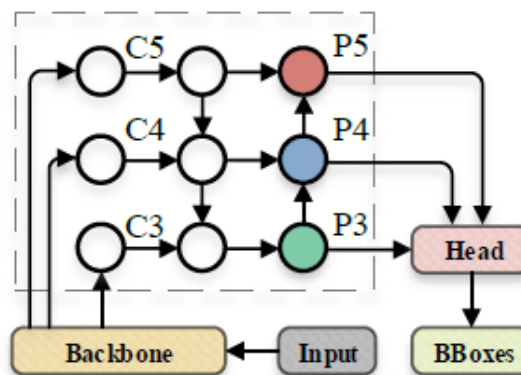

Fig 4 YOLOV5 Neck

##### 3. Detection Head:

YOLOv5 utilizes a detection head that predicts bounding boxes, class probabilities, and confidence ratings at different scales for each anchor box. This head is often made up of many convolutional layers.

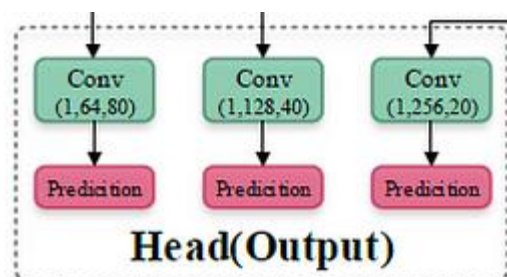

Fig 5 YOLOV5 Head

### 4. Output:

The end result is a collection of bounding boxes, each with its own class and confidence score. Non-maximum suppression is used to eliminate duplicate detections and retain just the most confident ones.

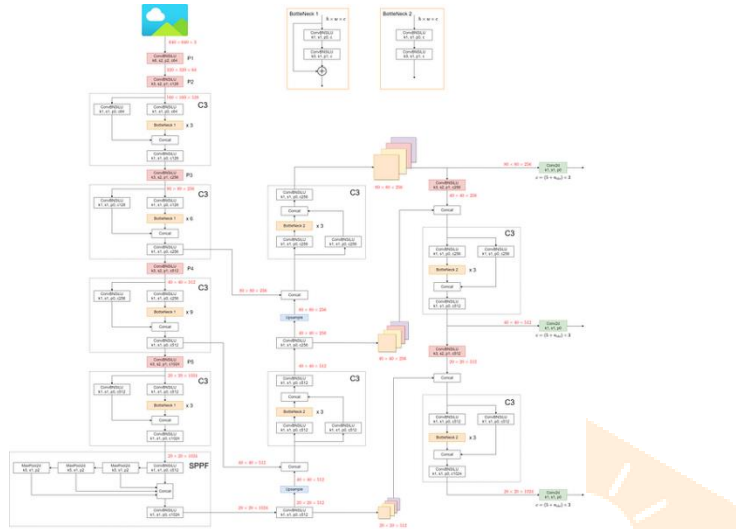

Fig 6 YOLOV5 Detailed Architecture

## 5. EXPERIMENTAL RESULTS

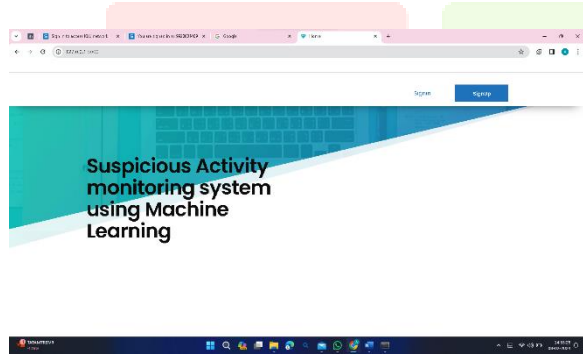

Fig 7 Home Page

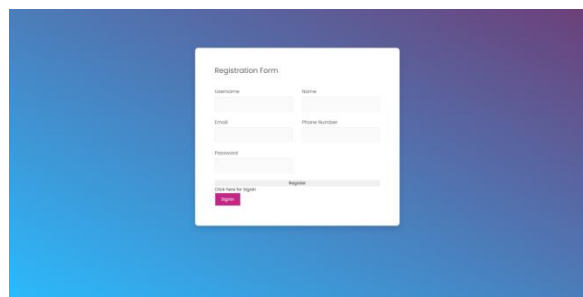

Fig 8 Registration Page

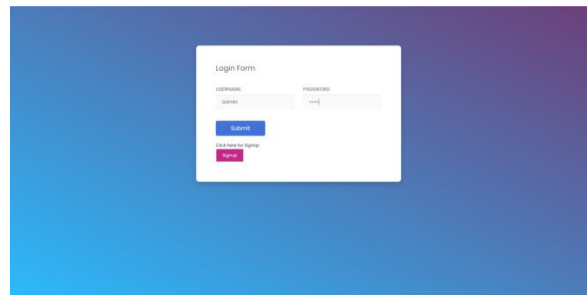

Fig 9 Login Page

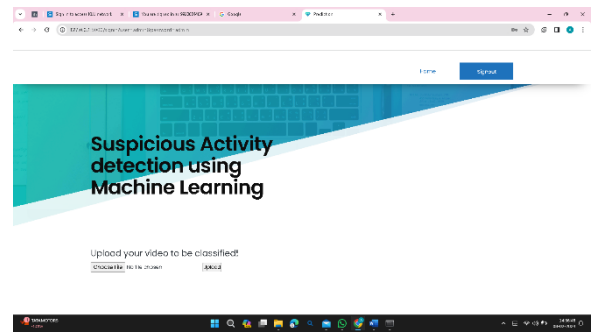

Fig 10 Main Page

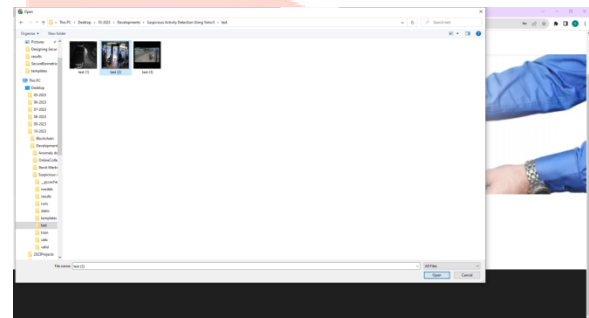
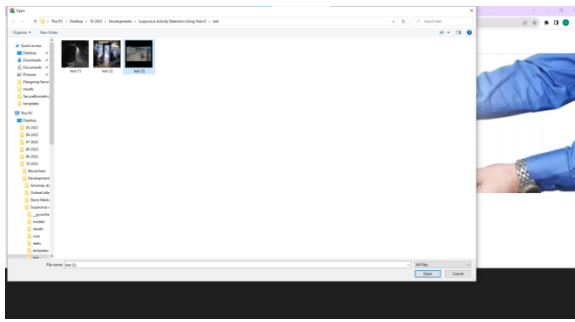

Fig 11 Upload Input Image



Fig 12 Prediction Result For Given Input



**Fig 13 Upload Another Input Image**



**Fig 14 Prediction Result For Given Input Image**

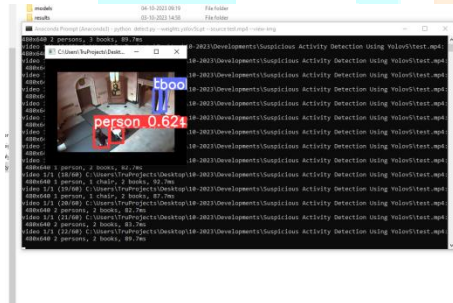

**Fig 15 Prediction Result For Video Testing Page**

## 6. CONCLUSION

At long last, in our undeniably computerized world, the use of the YOLOv5 calculation for the ID of suspicious activities in photographs and recordings is a basic and critical drive. This instructional exercise has introduced a bit by bit methodology to developing a proficient reconnaissance and inconsistency recognition framework. YOLOv5, which is perceived for its astonishing accuracy and snappiness, is a brilliant choice for this reason. The principal part of this book focused on the meaning of designing the fitting climate with essential libraries and conditions to guarantee a smooth work process. Bringing in and setting up the dataset in the Just go for it design, as made sense of in the subsequent part, is a significant stage in effectively preparing the model. This stage is at times ignored, despite the fact that it is basic to the venture's prosperity. The

third portion underscored the need of exploratory data analysis (EDA) for YOLOv5, which guarantees the precision and nature of explanations, as well as picture consistency with the rules of YOLOv5. These techniques, taken together, make the structure for fostering areas of strength for a framework. The aide's heart is given to the utilization of the YOLOv5 calculation. It makes sense of how for load the model, train it on your provided dataset, or tweak a pre-prepared model to meet your remarkable requirements. Furthermore, we inspected evaluation measures to help you properly survey the model's presentation. At long last, this book inspected the prepared model's commonsense purposes, whether continuously or cluster surmising, making it an incredible device for security, observation, and an assortment of other use cases. Carrying out YOLOv5 might be a unique advantage in the present computerized world, when the interest for compelling observing and oddity location is higher than at any other time. This article is an intensive asset for anyone wishing to utilize the capability of YOLOv5 to distinguish dubious action. You might create and carry out a strong item recognition framework that further develops security, wellbeing, and functional productivity by following these means.

## REFERENCES

- [1] Vikas Tripathi; Hindawi Publishing Corporation, "Robust Abnormal Event Recognition via Motion and Shape," Journal of Electrical and Computer Engineering, pp. 1-11, 2015.
- [2] Pushpajit A. Khaire and Praveen Kumar, "RGB+D and deep learning based real time detection of suspicious," Springer; Journal of Real-Time Image Processing, pp. 1-13, 2021.
- [3] P. A. Khaire, "RGB+D and deep learning based real time detection of suspicious," Journal of Real-Time Image Processing, pp. 1-13, 21.
- [4] C. Shiranthika, "Human Activity Recognition Using CNN & LSTM," IEEE, 2021.

- [5] T. S. Bora, "HUMAN SUSPICIOUS ACTIVITY DETECTION SYSTEM USING CNN MODEL FOR VIDEO SURVEILLANCE," IJARIE, 2021.
- [6] R. Vrskova, "A New Approach for Abnormal Human Activities Recognition," Sensor, 2022.
- [7] S. Sabbu, "LSTM-Based Neural Network to Recognize Human Activities," Hindawi, pp. 1-8, 2022.
- [8] Rajeshwari S, Vismitha G, Sumalatha G and Safura Aliya, "Unusual Event Detection for Enhancing ATM Security," International Journal of Innovative Research in Electrical, Electronics, Instrumentation and Control Engineering, pp. 1-6, 2021.
- [9] J. R. Kwapisz, G. M. Weiss, and S. A. Moore, "Activity recognition using cell phone accelerometers," SIGKDD Explor. Newsl., vol. 12, no. 2, pp. 74–82, Mar. 2011, doi: 10.1145/1964897.1964918.
- [10] A. Murad and J.-Y. Pyun, "Deep Recurrent Neural Networks for Human Activity Recognition," Sensors, vol. 17, no. 11, p. 2556, Nov. 2017, doi: 10.3390/s17112556
- [11] P. Kuppusamy and C. Harika, "Human Action Recognition using CNN and LSTM-RNN with Attention Model" International Journal of Innovative Technology and Exploring Engineering(IJITEE), vol.8,Issue 8, pp.1639-1643, 201
- [12]<https://www.analyticsvidhya.com/blog/2022/03/basics-of-cnn-in-deep-learning>
- [13] Y. Chen, K. Zhong, J. Zhang, Q. Sun, and X. Zhao, "LSTM Networks for Mobile Human Activity Recognition," presented at the 2016 International Conference on Artificial Intelligence: Technologies and Applications, Bangkok, Thailand, 2016, doi: 10.2991/icaaita-16.2016.13
- [14] <https://ieeexplore.ieee.org/document/904397>
- [15] <https://towardsdatascience.com/convolutional-neural-networks-explained-9cc5188c4939>
- [16] C. Jobanputra, J. Bavishi, and N. Doshi, "Human Activity Recognition: A Survey," Procedia Computer Science, vol. 155, pp. 698–703, 2019, doi: 10.1016/j.procs.2019.08.100
- [17] <https://deepai.org/publication/evaluating-two-stream-cnn-for-video-classificatio>
- [18]<https://www.codeproject.com/Articles/1366433/Using-Modified-Inception-V3-CNN-for-Video-Processin>
- [19]<https://www.kaggle.com/datasets/mehantkammakomati/atm-anomaly-video-dataset-atma>
- [20] A. Murad and J.-Y. Pyun, "Deep Recurrent Neural Networks for Human Activity Recognition," Sensors, vol. 17, no. 11, p. 2556, Nov. 2017, doi: 10.3390/s17112556
- [21] T. Zebin, M. Sperrin, N. Peek, and A. J. Casson, "Human activity recognition from inertial sensor time-series using batch normalized deep LSTM recurrent networks," in 2018 40th Annual International Conference of the IEEE Engineering in Medicine and Biology Society (EMBC), Honolulu, HI, Jul. 2018, pp. 1–4, doi: 10.1109/EMBC.2018.8513115.
- [22][https://github.com/pjreddie/darknet/blob/master/data/coco\\_names](https://github.com/pjreddie/darknet/blob/master/data/coco_names)
- [23] <https://machinelearningknowledge.ai/a-brief-history-of-yolo-object-detection-models>
- [24] <https://www.irjet.net/archives/V8/i4/IRJET-V8I4809.pdf>
- [25] M. Sabokrou, M. Fathy, M. Hoseini, and R. Klette, "Real-time anomaly detection and localization in crowdedness," in The IEEE Conference on Computer Vision and Pattern Recognition (CVPR) Workshops, June 2015.
- [26] C. Lu, J. Shi, and J. Jia, "Abnormal event detection at 150 fps in matlab ," in Proceedings of the IEEEinternational conference on computer vision, 2013.
- [27] Lu, S. (2019). Deep learning for object detection in video Journal of Physics Conference Series, 1176.
- [28] Simonyan, K., Zisserman, A. (2014). Two-stream convolutional networks for action recognition in videos.