



REINFORCING RESTRICTED AREA SAFETY THROUGH RFID-ENABLED SPEED CONTROL

¹Saili S. Sonawane, ²Rohini J. Patil, ³Bhagyashree S.Raipurkar, ⁴Janhavi S. Walde, ⁵Mrs.Tejaswini Mane

¹Student, ² Student, ³ Student, ⁴ Student, ⁵Mentor
Electronics and Telecommunication Department,
SITS Engineering, Pune, India

Abstract: SpeedLock, an innovative project, enhances safety in restricted areas using RFID-enabled speed control. The ESP8266 microcontroller orchestrates communication between the RFID reader and DC motor, ensuring compliance with speed limits. Authorized vehicles with RFID tags gain access, while the system reduces speed for unauthorized or speeding vehicles. Real-time monitoring via Wi-Fi enables remote access to logs, ensuring compliance with safety regulations. SpeedLock is scalable, prioritizes safety measures, and integrates seamlessly for comprehensive security in designated zones.

Keywords - Micro controller unit; RFID Module RFID Cards, DC Motor.

I. INTRODUCTION

SpeedLock introduces a groundbreaking project that enhances safety and security in restricted areas through the implementation of RFID-enabled speed control using the ESP8266 microcontroller to regulate the speed of a DC motor. This innovative solution aims to prevent unauthorized access to high-risk zones by enforcing speed limits on vehicles and equipment within designated areas.

The core objective of SpeedLock is to create a robust safety mechanism that ensures compliance with speed regulations in restricted zones. The ESP8266 microcontroller acts as the central control unit, orchestrating seamless communication between the RFID reader and the DC motor's speed control system.

The system integrates RFID technology to identify authorized vehicles and equipment within the restricted area. Each authorized vehicle is equipped with an RFID tag that transmits unique identification information to the RFID reader. Upon detecting an authorized RFID tag, the ESP8266 microcontroller grant access and simultaneously regulates the DC motor's speed to the predefined safe limit.

In the absence of an authorized RFID tag or if the vehicle exceeds the permissible speed limit, the ESP8266 microcontroller initiates safety measures. The speed control system reduces the DC motor's speed to a safe threshold, preventing the vehicle from exceeding the designated limit and enhancing the overall safety within the restricted area.

To ensure real-time monitoring and control, the SpeedLock system employs Wi-Fi connectivity through the ESP8266 microcontroller. This feature allows administrators and security personnel to remotely monitor access logs, vehicle speed, and ensure compliance with safety regulations from a central control station.

II. EXPERIMENTAL MODEL

RFID Module:

RFID or Radio Frequency Identification system consists of two main components, a transponder/tag attached to an object to be identified, and a Transceiver also known as interrogator/Reader. A Reader consists of a Radio Frequency module and an antenna which generates high frequency electromagnetic field.

RFID Cards:

Radio Frequency Identification (RFID) is the wireless non-contact use of radiofrequency waves to transfer data. Readers, also called interrogators, are devices that transmit and receive radio waves in order to communicate with RFID tags.

12V DC Motor:

12V Dc Motor is used in this Project which will be connected to the Motor Driver Module. The Controller sends the data to the Motor via Motor driver and then the Motors are controlled.

Power Supply:

9V Battery is used to power the control circuit of the Project. Controller supports from 7-12 V DC Supply. Once the Power is received, it generates the 5V and 3.3V Signal from its VCC and GND Pin.

III.WORKING

This process involves regulating the velocity of an entity upon entering specific areas like hospitals or academies using an RF module. The system comprises a transmitter module positioned on the roadside and a receiver module embedded within the entity. Radio signals emitted from the transmitter module are received and compared against recorded speed data. If the entity's speed is below the recorded value, it remains unaffected; otherwise, it undergoes automatic speed control. The entity's speed is visually presented on a TV module. In the event of emergencies, such as an ambulance, a designated switch is available. When activated, the entity's speed is exempted from automatic control, and its identification is logged. In the case of an ambulance, the system autonomously reduces the speed of other vehicles using the same transmitter module. This entire process is facilitated by the cost-effective and highly integrated ESP8266 module.

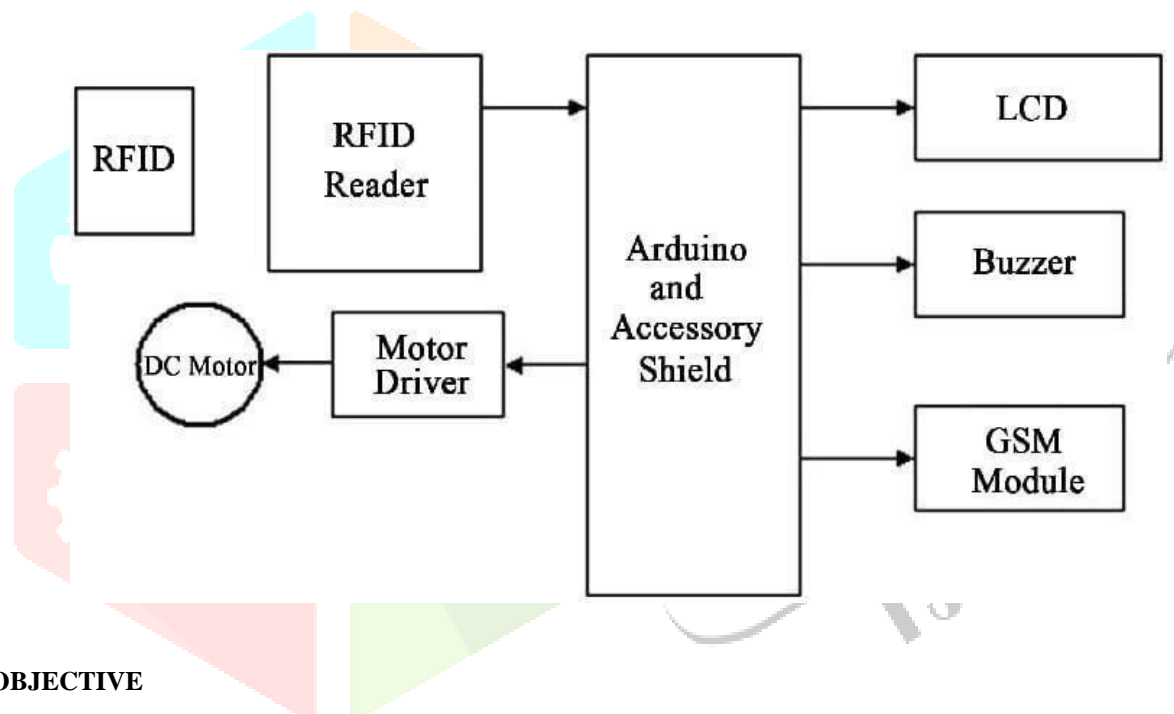
3.1 BLOCK DIAGRAM**IV. OBJECTIVE**

Enhanced Restricted Area Safety: SpeedLock aims to enhance safety and security by implementing RFID-enabled speed control to regulate vehicle speed within restricted areas.

Access Control: The integration of RFID technology allows for seamless access control, permitting only authorized vehicles and equipment to operate within the designated zones.

V. FUTURE SCOPE

- 1) AI can be added to the existing system to make it more advanced
- 2) Camera can be added to take the picture of the Sign board and take the action automatically

VI. CONCLUSION

This study focuses on using IoT technology to detect vehicle overspeed in urban areas, improving safety. The Smart Vehicle Overspeed Detector enhances detection accuracy to prevent accidents and report violators. Potential future upgrades could further enhance this system. The goal is to reduce speeding and accidents, ultimately aiming for an automatic speed control system in cars to enhance safety for all road users.

REFERENCES

- [1] Kumari Nimmi , Ruby Kumari,Pragati Bag, “Wireless Motor Speed Control Using Rf Sensor,” Dept. Of Elect & Telecommunication, Bharath University Chennai-73.
- [2] Preeti, Sandeep Dogra, Rashmi Jain, “DC Drives: Microcontroller Based Control”.
- [3] Sudip K. Mazumder, “Rotor Position Feedback Over An RF Link For Motor Speed Control”, Senior Member, IEEE, Rongjun Huang, Student Member, IEEE, and Kaustuva Acharya.
- [4] Joshué Pérez *, Fernando Seco, Vicente Milanés, Antonio Jiménez, Julio C. Díaz And Teresa De Pedro, “An RFID-Based Intelligent Vehicle Speed Controller Using Active Traffic Signals”.
- [5] Ateeth Kumar Thirukkovulur¹, Harikrishna Nandagopal², Vigneesh Parivallal,” Intelligent Vehicle Control Based On Identification Of Road And Traffic Signal Operated RFID Transponders, International Conference On Advances In Electrical and Electronics Engineering (ICAEE'2012) Penang, Malaysia.

