



Analysis Of Different Isolation For Liquid Storage Tanks

Moman Ram¹, Mahendra Saini²

M. Tech Scholar¹, Assistant Professor², Regional Engineering College, Jaipur (Rajasthan)
Rajasthan Technical University (Kota)

ABSTRACT:- One of the important structures, which is prone to damage is water tank. Due to increase in urbanization, there are large numbers of elevated water tanks which are constructed. Therefore to evaluate the performance of elevated water tanks under seismic load is primarily important. The present study deal with evaluating the performance of a double Base Isolated elevated water tank (intze tank) is evaluated under far field and near field earthquakes. For the double base isolated water tank, the isolators are installed at bottom of tank and in the mid-way of staging. To typify the performance of double base isolated water tank, its seismic responses were also compared with the case of single base isolated (isolator at the base only) and fixed base counter parts.

Keywords: Base Isolation, seismic responses, isolators, mid-way of staging, fixed base etc.

INTRODUCTION:- The normally happening ground development which in the long run goes on making fiascos such as disappointment of structure and casualty is known as Seismic tremor. The vitality that's released from those seismic exercises makes waves; these waves are called as essential waves and auxiliary waves. The field of seismic plan may be a subject that bargains basically with life security and instability. For a few a long times presently, it has been a journey for auxiliary engineers to plan earthquake-proof buildings and bridges. At first, it has been by and large thought that building a gigantic and solid development would make it seismic tremor safe. But this firmness or inflexibility of the basic components would lead in the long run to a delicate and sudden disappointment, all in all not complying with the life security execution criteria and letting tenants no time to respond in case of an seismic tremor.

Storage tanks

Capacity tanks containing natural fluids, non-natural fluids, vapors and can be found in numerous businesses. Most capacity tanks are outlined and built on the premise of IITK-GSDMA rules for seismic plan of fluid capacity tanks. These tanks can have diverse sizes, extending from 2 to 60 m distance across or more. They are by and large introduced interior control bowls in arrange to contain spills in case of break of the tank.

Types of storage tanks

Basically, there are eight types of tanks used to store liquids:

- a. Fixed-roof tanks
- b. External floating roof tanks
- c. Internal floating roof tanks
- d. Domed external floating roof tanks
- e. Horizontal tanks
- f. Pressure tanks
- g. Variable vapour space tanks

h. LNG (Liquefied Natural Gas) tanks

LITERATURE REVIEW:- Praveen K. Malhotra [1] suggests a modern seismic separation strategy for cylindrical, ground-supported liquid-storage steel tanks. The approach involves isolating the tank wall from the base plate, supporting it on a ring of horizontally flexible bearings, and closing the gap with a flexible layer. This isolation significantly reduces hydrodynamic shears, moments, and axial compressive stresses during seismic events. The cost savings in foundation, anchorage, lateral restraint, and tank material are expected to outweigh the additional expenses for isolation bearings, flexible membrane, and base stiffener.

Praveen K. Malhotra [2] introduces a contemporary approach to seismic base separation for ground-supported vertical cylindrical liquid-storage tanks. In this strategy, the tank's base plate is placed on a soil bed, while the tank wall is supported by a ring of vertically flexible rubber bearings. This isolated system gains its flexibility from the shaking and uplifting of the base, and its energy-dissipation capacity is derived from base-plate yielding and soil damping.

Prasad S. Barve and Ruchi P. Barve [3] conducted a study on the seismic behavior of an Intze tank supported by a concrete shaft, focusing on the impact of changing the height-to-diameter ratio (h/d ratio). The h/d ratio is defined as the height of the water in the tank (h) divided by the inside diameter of the tank (d). The research reveals that as the h/d ratio increases, the unbalanced liquid pressure in the tank also increases, leading to higher base shear and base moment.

M.K. Shrimali and R.S. Jangid [4] conducted a comparative study on various confinement systems for liquid storage tanks, reaching the conclusion that these systems effectively reduce the seismic acceleration transmitted to the tank, resulting in a significant reduction in design seismic forces. Notably, sliding-type isolation systems outperform elastomeric bearings in controlling the response of liquid storage tanks.

M.K. Shrimali and R.S. Jangid [5] conducted a seismic examination of base-isolated fluid storage tanks and found that non-classical damping effects are negligible in such systems. The classical modular superposition strategy is deemed suitable for analyzing the earthquake response of the tank. The key contributors to base shear and bearing displacement in confined tanks are identified as the moment mode, associated with the isolation process. In wide tanks, sloshing displacement is predominantly influenced by the primary mode (sloshing mode).

M.K. Shrimali and R.S. Jangid [6] explored the seismic response of fluid storage tanks isolated by sliding bearings, concluding that such isolators effectively reduce base shear and abrupt displacement of the tank. They found that the effectiveness of isolation increases with the flexibility of the sliding system. Interestingly, the friction coefficient's dependence on the relative speed of the system has no significant impact on the peak response of isolated fluid storage tanks.

METHODOLOGY

Structural Control Methods

The civil engineering structures are invariably exposed to a variety of natural hazards such as strong winds, earthquakes and water waves which induce dynamic effects. Frequently not much can be done to decrease the level of such normal dangers to which structures are uncovered, and hence for a few decades the analysts have centered on diminishing the elements reaction by utilizing diverse sorts of auxiliary control strategies to move forward the security and execution of gracious structures. The analysts have created and progressed the concepts of detached and crossover base segregation, inactive vitality scattering strategies, and dynamic and semi-active control strategies.

In an ideal scenario, secure structures can be designed with precise information on loads and material properties, along with accurate structural analysis methods. However, real-world uncertainties exist in this data and analysis. To address these uncertainties, safety factors are incorporated in structural design. This article introduces the concept of structural control as an alternative approach to address safety concerns in structural engineering. It reviews key points in control theory and highlights pioneering work in this area. The practicality of this concept is demonstrated using a case study with simple parallel logic devices. Further research is needed to apply structural control to complex structures, such as tall buildings or long bridges exposed to uncertain dynamic loads like wind and earthquakes.

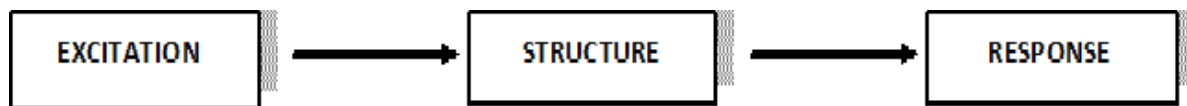

Figure 3.1: Conventional Base Structure

Evolution of structural control:- Over the past four decades, researchers have explored various approaches to mitigate the impact of extreme events, particularly earthquake-induced ground motions. Three fundamental methods have emerged for dynamic response mitigation:

Base Confinement: This approach involves introducing isolators, such as rubber bearings, between the structural foundation and superstructure to filter out damaging seismic energy. The isolators shift the fundamental period of the combined system to a lower input motion range. This method has been successfully implemented globally, with ongoing refinements using advanced materials to dynamically control system characteristics.

Energy Absorbing Devices: Also known as energy dissipaters or sinks, these devices are strategically placed within structures to safely dissipate dynamic energy. Extensive research in the 1980s focused on various types, including viscous dampers, yielding metallic dampers, and friction dampers. These devices absorb and dissipate vibration energy, enhancing structural safety and sometimes adding stiffness. Analytical methods were developed to integrate these devices into structural design, ensuring optimal sizing and placement. They have gained confidence in the design profession, being used in both retrofitting older structures and enhancing the seismic resilience of new constructions. While they require increased initial investment, their effectiveness is well-established, and they can be designed for replacement if damaged.

Types of structural control system

Structural control systems are broadly classified as

- 3.3.1 Passive control system
- 3.3.2 Active control system
- 3.3.3 Semi-active control system
- 3.3.4 Hybrid control system

4 The passive control device includes

Base Isolation

Base isolation is a widely used seismic protection method for structures. In this technique, a building is supported by bearing pads between the structure and its foundation. The concept is akin to placing a building on frictionless rollers, allowing the structure to remain stationary during ground shaking. This prevents seismic forces from being transferred to the building, effectively shielding it from earthquake damage. Buildings with low lateral stiffness, like those resting on flexible cushions, benefit from base isolation by filtering out high-frequency ground motion.

The effectiveness of base isolation depends on factors such as soil type and building characteristics. It is most suitable for low to medium-rise structures on firm soil with a low fundamental period. However, it may not be as effective for tall buildings or those on soft soil with a high fundamental period.

Base isolators, which act as flexible cushions, absorb energy and dampen the seismic response of the structure. They can be elastic pads or devices allowing controlled sliding between different parts of the building. This technology enhances the flexibility of a structure, making it more resilient. Base-isolated buildings maintain their original shape and experience reduced inertial forces during seismic events, leading to significantly lower accelerations compared to fixed-base buildings.

Types of bearing

Lead Rubber Bearing

Commonly used types of base isolation bearings include lead rubber bearings. These bearings consist of layers of rubber sandwiched between steel layers, with a solid lead core. The bearing is rigid and strong in the vertical direction but flexible horizontally. Lead, being crystalline, temporarily changes its structure under stress but regains its original properties when the stress is removed, making it suitable for multiple loading cycles.

To understand how base isolation works, consider seismic forces acting on a base-isolated building versus a traditional fixed-base building. In an earthquake, the ground beneath both buildings begins to move. The base-isolated building responds with movement toward the right, but due to its flexible nature, it does not undergo significant distortion. On the other hand, the fixed-base building not only moves but also undergoes deformation, changing its shape from a rectangle to a parallelogram. Seismic damage to buildings is primarily caused by this deformation resulting from inertial forces during an earthquake.

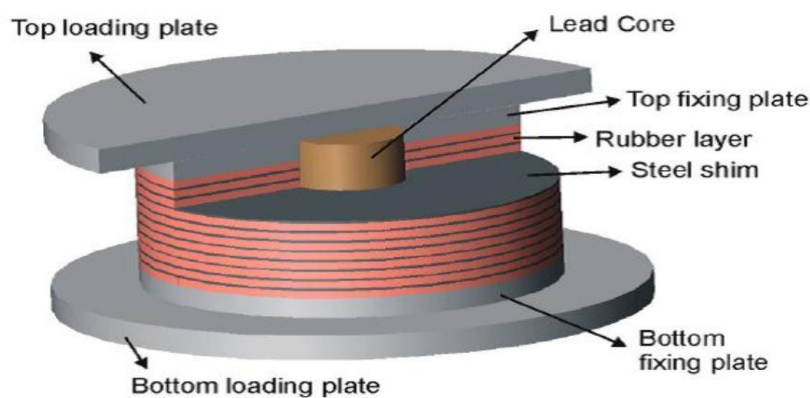

Figure 3.2: Lead Rubber Bearing

This illustrates the fundamental principle of base isolation, where the flexibility of the isolator limits the building's deformation, reducing the risk of seismic damage. The use of lead rubber bearings exemplifies the effectiveness of this approach in enhancing a structure's seismic resilience.

Elastomeric Isolation System:- Common seismic isolation systems often utilize elastomeric bearings, consisting of thin rubber sheets vulcanized and bonded to thin steel plates, with an integrated energy dissipation mechanism.

The internal steel plates provide vertical load capacity and stiffness, preventing lateral bulging of the rubber. Lateral stability is ensured by the steel plates, restricting the rubber sheets' deformation in that direction. Thick mounting steel plates are reinforced at the top and bottom, allowing a firm connection to both the foundation below and the superstructure above.

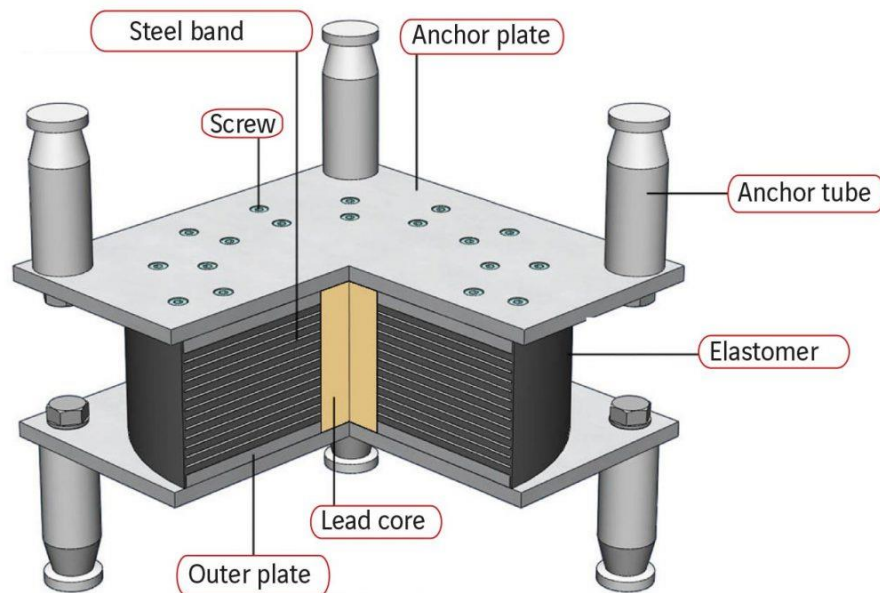

Figure 3.3: Elastomeric isolation system

The energy dissipation mechanism can be based on the plastic deformation of metal or the inherent damping properties of rubber. Lead plugs may be inserted into the elastomeric bearing for plastic deformation, or auxiliary dampers based on lead or steel deformations can be used. Lead rubber bearings (LRBs) and high-damping rubber bearings (HDRBs) are particularly effective in seismic isolation, offering vertical support, horizontal flexibility, and energy dissipation within a single unit.

These systems provide several key benefits, including high vertical stiffness to prevent excessive shaking, horizontal flexibility to shift the structural frequency away from resonance, and energy dissipation through either plastic deformation of lead or the damping properties of high-damping rubber. Additionally, some systems use natural rubber bearings (NRBs) with additional steel or lead dampers for energy dissipation through plastic deformation of the damper.

High Damping Rubber Bearing (HDRBs):- HDRBs are a specialized form of seismic isolation that leverages high-damping rubber to enhance energy dissipation during seismic events. Their unique composition and effective damping properties contribute to their application in mitigating seismic forces. Nevertheless, careful consideration is required to address potential limitations in initial stiffness under specific loading conditions, highlighting the importance of a comprehensive understanding of the structural response when employing HDRBs in seismic design.

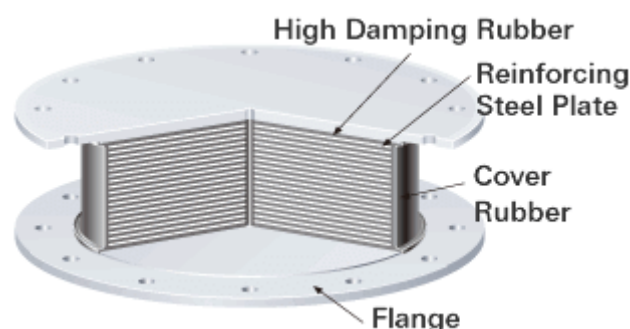

Figure 3. 4 High Damping Rubber Bearing

Hybrid Type: Lead High Damping Rubber Bearing

The strategic placement of LHDRBs beneath exterior columns away from the center enhances resistance against torsion due to the larger distance between the points of force application and the center of stiffness of the isolation system. However, this configuration is feasible only when a rigid diaphragm is present at the isolation level to redistribute inertia forces to the LHDRBs.

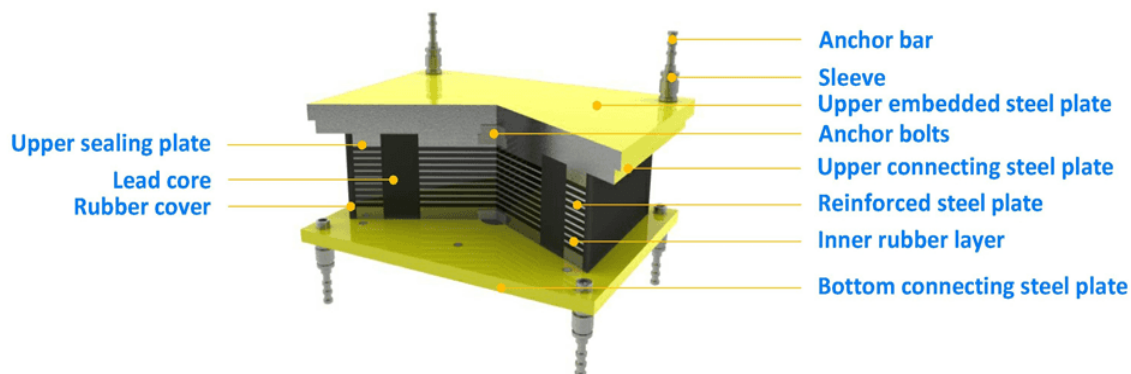

Figure 3. 5 Lead high damping rubber bearing

Maintenance and Management of the Isolation System: the longevity and performance of a seismic isolation system depend on protective measures against environmental impacts, regular maintenance, and careful consideration of design factors. These factors include accommodating lateral forces, anticipating diaphragm construction, and ensuring accessible locations for inspection and potential replacement. Adopting these practices enhances the reliability and effectiveness of seismic isolation systems throughout the expected lifespan of the structure.

Factors Which Enable Use of Base Isolation:- the demand for improved seismic performance, coupled with advancements in computer technology and structural analysis, the availability of testing facilities like shaking tables, considerations of minor loads, and progress in structural materials collectively contribute to the development and successful application of seismic isolation techniques. These factors pave the way for more resilient structures capable of withstanding seismic events and protecting sensitive equipment.

Practical application of Base Isolation:- In theory, a perfectly functioning seismic isolation system would experience no lateral seismic forces on the isolated superstructure. However, if building codes and authorities continue designing superstructures to withstand the same lateral forces as fixed-base structures, there may be no cost savings. This is because the superstructure would require similarly robust steel sections or massive reinforced-concrete dimensions to counteract relatively light lateral seismic forces.

The first seismically isolated bridge with added damping was the TeTeko viaduct in New Zealand, constructed in 1988. The isolation system featured a layered sandwich of steel and rubber bearings with a central lead core for energy dissipation, commonly known as lead-rubber bearings. The William Clayton Building in Wellington, New Zealand, became the first structure equipped with lead-rubber bearing isolation in 1981.

The development of seismic isolation technology has seen successful applications globally, with notable examples showcasing its effectiveness in mitigating the impact of earthquakes on various structures. Despite early challenges, seismic isolation has become an integral part of earthquake-resistant design practices.

DESIGN DATA

Design Data for Tank**Table 1** Design Data of Tank

Design Data	Specification
Desired Capacity of tank	442.84m ³
Height of FSL from top of foundation beam	26 m
Grade of Concrete used	M-25 (Foundation)&M-30 (For container)
Grade of Steel used	Fe 550
Safe bearing capacity of soil	175 kN/m ²
Seismic Zone	III

Table 2 Dimension of Intze Type Tank

Intze Type Tank Component	Dimensions(m)
Top Diameter of Tank (D)	10
Bottom Diameter of Tank (D ₁)	6
Outer Diameter of cylindrical Shaft (D ₂)	1.5
Rise of Top dome (h ₀)	2
Rise of Conical Dome (h ₁)	2
Rise of Bottom Dome (h ₂)	1.5
Height of cylindrical Shaft (h ₃)	5

Table 3 Dimensions of Staging

Components	Dimensions(mm)
Size of columns	600 × 600
Size of beams	400 × 600
Size of foundation beam	500 × 700
Size of ring beam	150 × 150
Size of bracing	400 × 600
Upper slab thickness	100
Side wall thickness	200

4.2 Earthquake Details:

S.NO.	Year	Earthquake	Mw	Station	PGA(g)	PGV(cm/s)	PGD(cm)	dt	Npts.
1.	1992	Landers	7.28	Bakers fire station	0.107	9.25	6.54	0.02	2500
2.	1983	Coalinga	6.36	Park field fault zone 14	0.2738	28.14	4.875	.001	6499

Table 4 Near Field Records (Forward Directivity)

S.NO.	Year	Earthquake	Mw	Station	PGA(g)	PGV(cm/s)	PGD(cm)	dt	Npts.
1.	1994	Northridge	6.69	La Dam	0.426	74.34	19	0.005	5315
2.	1999	Kocaeli	7.51	Gebze	0.144	32.64	29.76	0.005	5600

Table 5 Near Field Record (Fling step Effect)

S.NO.	Year	Earthquake	Mw	Station	PGA (g)	PGV	PGD(cm)	dt	Npts.
1.	1999	Kocaeli	7.4	Sakarya	0.41	82.05	205.93	0.01	5501
2.	1999	Chi-chi	7.6	TCU067	0.48	94.31	181.5	0.005	14001

4.3 Modal Analysis

Figure 4.1-4.3 show the different structures i.e., figure 4.1 shows fix base structure in which base of the structure is fix, figure 4.2 shows base isolated structure in which base of the structure is isolated with the help of one link joint isolators and figure 4.3 shows double isolated structure in which base is isolated with one link joint isolator and at the level of staging, isolation is done by two link joints.

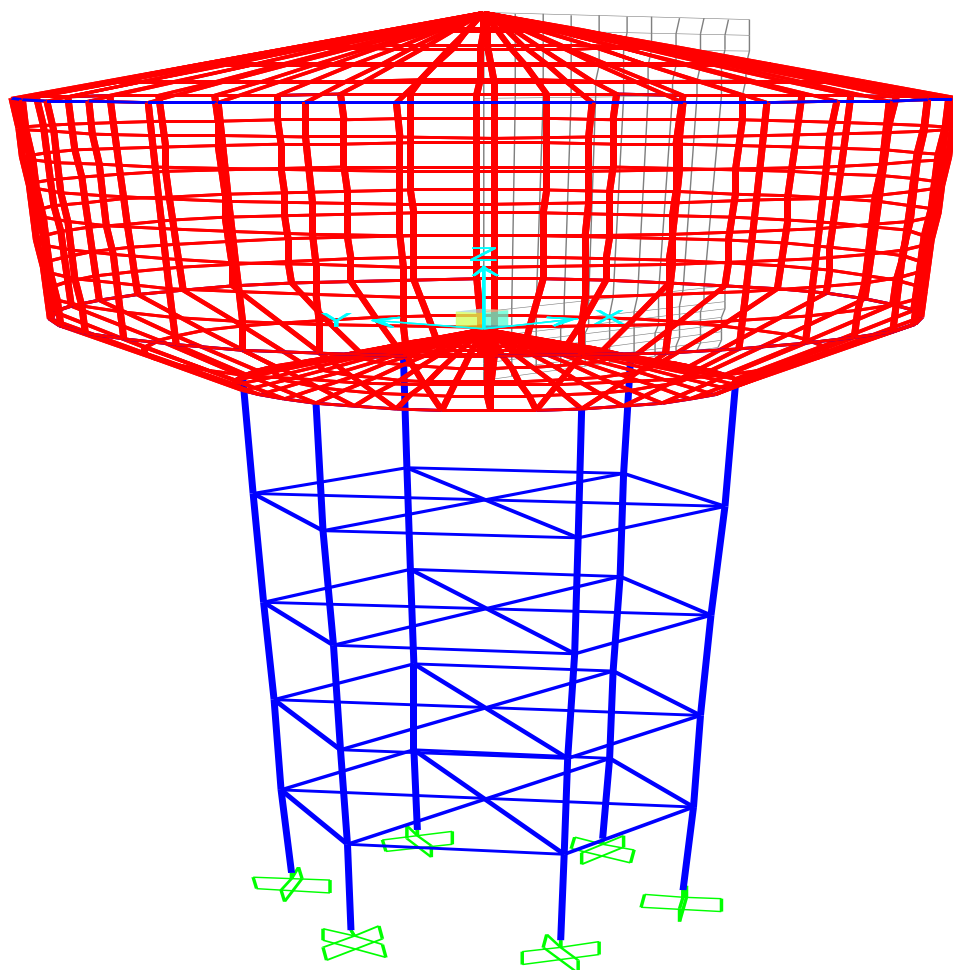

Figure 4.1: Fixed Base Structure in SAP2000

Properties of Isolator

Table 6 Properties Used for Linear Analysis Case (At Base)

Design load	740KN
Effective stiffness	331
Damping	0.1

Table 7 Properties Used for Non Linear Analysis Case (At Base)

Initial stiffness (K_1)	1768
Yield strength	15.91
Post yield stiffness ratio	0.1

Table 8 Properties Used for Linear Analysis Case (At 3rd Level of Staging)

Design load	529KN
Effective stiffness	237
Damping	0.1

Table 9 Properties Used fFor Non Linear Analysis Case (At 3rd Level of Staging)

Initial stiffness (K_1)	2467
Yield strength	22.2
Post yield stiffness ratio	0.1

RESULT AND DISCUSSION

For Base Shear:

Comparison graphs from figure 5.1 for base shear have been plotted between fix base structure, base isolated structure and double isolated structure:

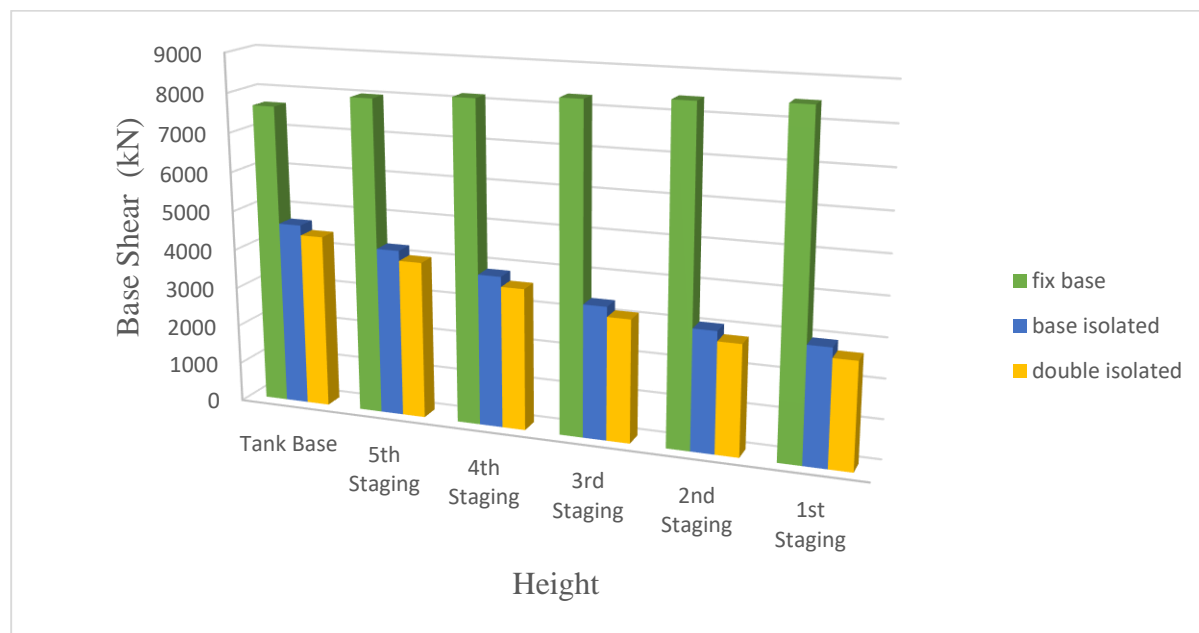

Figure 5. 1: Comparison graph between fix base structure, base isolated structure and double isolated structure for base shear

From figure 5.1 It is observed that the base shear for fixed base comes out to be very high nearly of the order 7500 KN to 9000 KN. For base isolated tanks, the base shear is drastically reduced as compared to that of fixed base, nearly of the order 3000 KN. For double isolated tanks, the base shear is slightly less than that of single isolated tank.

5.2 For Absolute Acceleration:

Comparison graphs from figure 5.2 for absolute acceleration for joints have been plotted between fix base structure, isolated structure and base isolated structure for

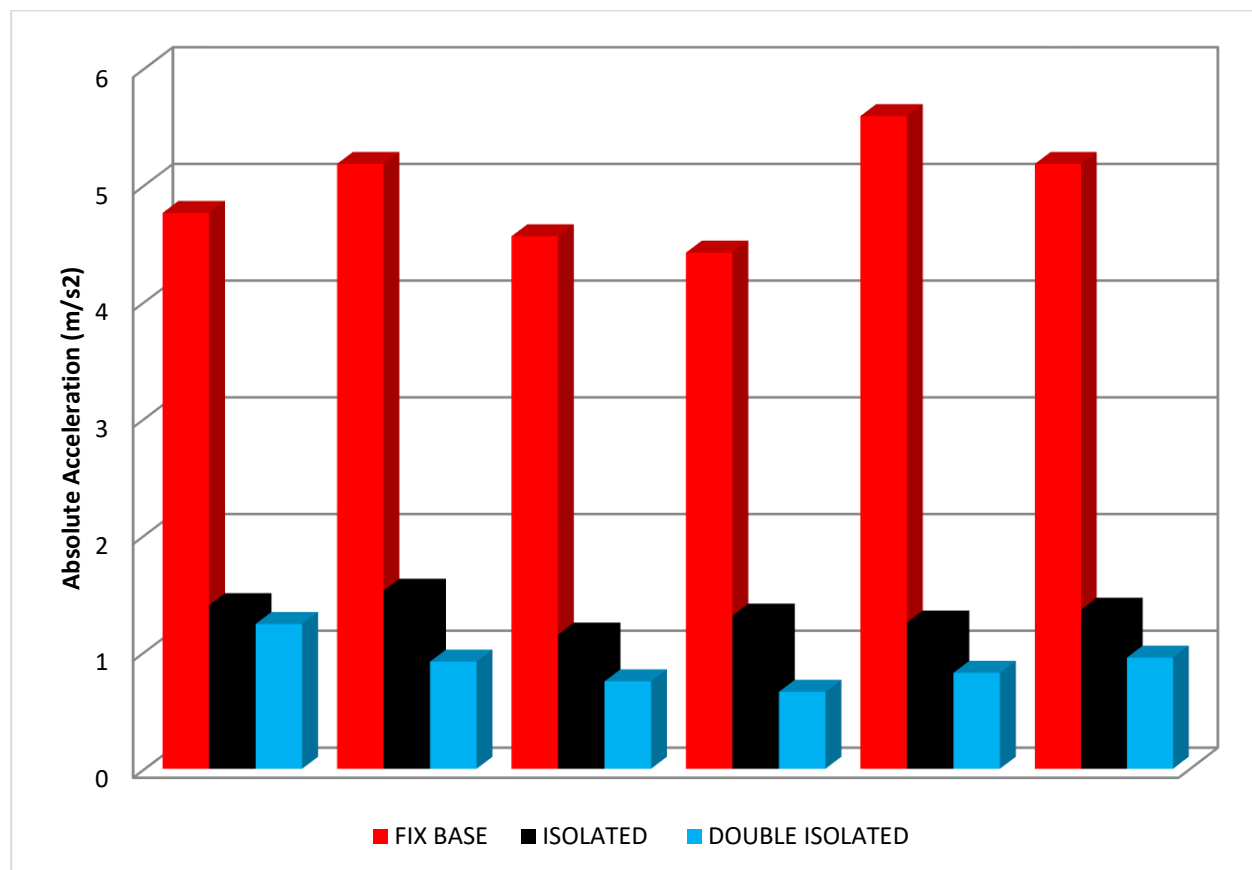

Figure 5.2: Comparison graph between fix base structure, base isolated structure and double isolated structure for absolute acceleration

From fig. 5.2 It is observed that the outright increasing speed for settled base tanks are exceptionally tall. For single disconnected tanks, the outright speeding up is radically decreased as compared to that of settled base. For two-fold disconnected tanks, there's a slight decrement for outright increasing speed as compared to single separated tanks.

CONCLUSION AND FUTURE RECOMMENDATIONS

6.1 Concluding Remarks:

In the present study, the effectiveness of a double base isolated water tank is evaluated against the single base isolated and fixed base versions. Lead rubber bearing isolator is used as the base isolation system. In order to study the effect of different types of earthquakes, different sets of far fields and near field earthquake with directivity effect and fling step effect are considered. The non-linear time history analysis is performed to calculate different structural response parameters namely base shear, absolute acceleration. For the specific problem analysed, the important calculations drawn from the study mentioned below.

- I. The performance of the elevated water tank is increased under both near and far field earthquakes by using base isolation system.
- II. There is high percentage reduction (80-85%) in the base shear and absolute acceleration under both near field and far field earthquakes.
- III. The efficiency of double base isolated is high in comparison to single base isolated under far field earthquakes.

- IV. Double base isolated effectively reduces the base shear and absolute acceleration by 25%-50% for far field earthquakes and 12%-50% for near field earthquakes.
- V. For the specific problem analysed, it is highly recommended to use double base isolation system where the tank is situated in high seismic zone or subjected to near field earthquakes.

Reference:-

1. Malhotra, P. K. (1997). New method for seismic isolation of liquid-storage tanks. *Earthquake engineering & structural dynamics*, 26(8), 839-847.
2. Malhotra, P. K. (1997). Method for seismic base isolation of liquid-storage tanks. *Journal of Structural Engineering*, 123(1), 113-116.
3. Barve, P. S., & Barve, R. P. INTERNATIONAL JOURNAL OF ENGINEERING SCIENCES & RESEARCH TECHNOLOGY PARAMETRIC STUDY TO UNDERSTAND THE SEISMIC BEHAVIOUR OF INTZE TANK SUPPORTED ON SHAFT.
4. Shrimali, M. K., & Jangid, R. S. (2002). A comparative study of performance of various isolation systems for liquid storage tanks. *International Journal of Structural Stability and Dynamics*, 2(04), 573-591.
5. Shrimali, M. K., & Jangid, R. S. (2004). Seismic analysis of base-isolated liquid storage tanks. *Journal of Sound and Vibration*, 275(1-2), 59-75.
6. Shrimali, M. K., & Jangid, R. S. (2002). Seismic response of liquid storage tanks isolated by sliding bearings. *Engineering Structures*, 24(7), 909-921.
7. Dowrick, D. J. (2003). *Earthquake risk reduction*. John Wiley & Sons.
8. Jadhav, M. B., & Jangid, R. S. (2006). Response of base-isolated liquid storage tanks to near-fault motions. *Structural Engineering and Mechanics*, 23(6), 615-634.
9. Shrimali, M. K. (2007). Seismic response of elevated liquid storage steel tanks under bi-direction excitation. *Steel Structures*, 7, 239-251.
10. Livaoglu, R., & Dogangun, A. (2007). Effect of foundation embedment on seismic behavior of elevated tanks considering fluid-structure-soil interaction. *Soil Dynamics and Earthquake Engineering*, 27(9), 855-863.

