



Motorcycle Crash Detection And Alert System Using Iot

Mr. Riyazulla Rahman J
Assistant professor, School of CSE
Presidency University

Keerthana Manoj
Student
Presidency University

Abstract: This study introduces an economical and resilient vehicle crash detection and alert system by integrating the TTGO T-Call ESP32 module, Airtel SIM card, GPS Neo 6M, MPU 6050 gyro sensor, and other essential components. The system continually monitors the vehicle's motion and orientation, leveraging the MPU 6050 gyro sensor and GPS Neo 6M for real-time data. In the event of a crash, the system promptly alerts pre-configured emergency contacts through the Airtel SIM card. User-friendly features, including a push button and a slide on-off switch, enhance the system's accessibility and control. The integration of a 3.7 lithium-ion battery, coupled with a dedicated battery charging module, ensures a consistent and reliable power supply for prolonged operation. Experimental validation showcases the system's effectiveness in accurately detecting crashes and promptly notifying emergency contacts. The system's capabilities position it as a practical and affordable solution for enhancing vehicle safety and emergency response mechanisms. This research significantly contributes to the field of intelligent transportation systems by providing a cost-effective and accessible approach to vehicle crash detection. The simplicity, efficiency, and utilization of low-cost components make this system suitable for widespread adoption, effectively addressing critical aspects of vehicle safety and emergency communication. The integration of advanced features and robust performance makes it an invaluable tool for promoting safer roads and efficient emergency response.

1. Introduction:

In today's rapidly evolving technological landscape, prioritizing vehicle safety is paramount. Despite the dynamic and fast-paced nature of this era, the primary objective of this research is to present an affordable car crash detection and warning system. This system leverages cutting-edge components such as the BPSNeoEm, MT6030r sensor, and a thoughtfully selected collection of complementary hardware. At its core, this system forms a sophisticated network that continuously monitors the car's dynamics and its surrounding environment. The integration of the GPS Neo 6m and MPU 6050 gyro sensor enables real-time data collection, providing the system with precise information about the vehicle's orientation and position. This data serves as the basis for an intelligent detection algorithm, scrutinizing sudden changes in motion to identify potential collisions. Ensuring a reliable power source is integral to the system's functionality. Through the integration of a 3.7 lithium-ion battery, a battery charging and step-up module, along with additional supporting components, a stable power supply is maintained for uninterrupted system operation. Incorporating the TTGO T-Call Sim8001 ESP32 Wireless Communication Module further enhances the system's responsiveness. This module facilitates quick collision identification and timely alert transmission, holding significant promise in mitigating the impact of car accidents. The comprehensive approach to hardware integration and the intelligent algorithm underscore the system's potential to significantly reduce the consequences of automotive collisions, contributing to the ongoing pursuit of enhanced vehicle safety. This project seeks to elevate the standard for proactive crash detection and response, aligning with the evolving landscape of societal and technological integration. The solution aims to be both practical and widely comprehensible, emphasizing the

simplicity of its design. Notably, the system's viability and scalability for broader implementation are underscored by its reliance on readily available and cost-effective and economically sustainable components. Given below is the circuit diagram

2. Literature Review:

A global commitment to improving road safety through technology innovation is reflected in the significant attention that the development of intelligent vehicle collision detection and alert systems has received in recent publications. The integration of several sensor technologies and communication modules for effective and timely collision detection has

been the subject of numerous studies. Its adaptability and connection have led to the use of the TTGO T-Call Sim8001 ESP32 Wireless Communication Module in automotive safety and quick emergency response, and lessening the severity of after-collision effects. The fact that Airtel Sim cards were used as the communication channel highlights how realistic it is to use the current telecommunications infrastructure for wider adoption. GPS technology is essential in accident detection systems because it provides precise location data, as demonstrated by the GPS Neo 6m module. The body of research emphasises how crucial accurate geospatial data is to emergency services' ability to react

quickly. Research has indicated that the amalgamation of GPS modules with inertial sensors, such as the MPU 6050 gyro sensor, might augment the precision of the system in identifying abrupt alterations in vehicle motion, consequently augmenting the dependability of collision detection algorithms.

Enhancing system accessibility and usability has been explored in relation to the addition of user-interface

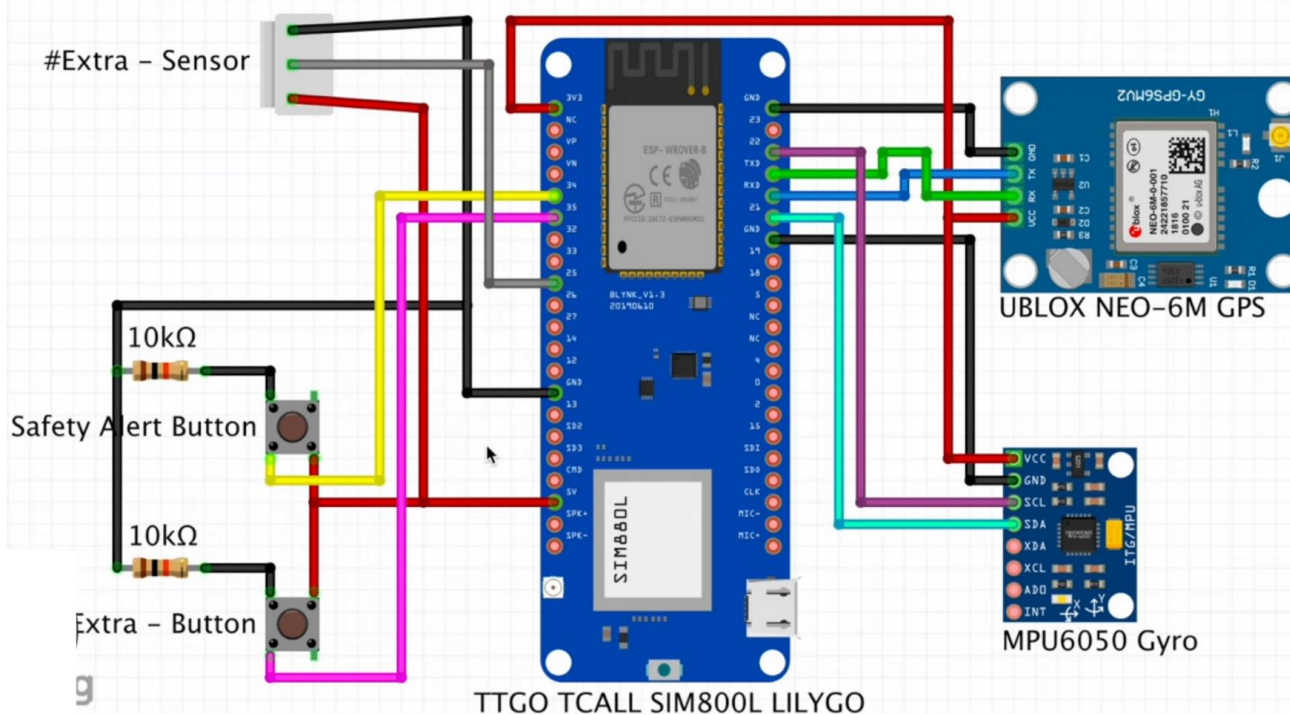

components like the sliding on-off switch and push button. According to research, user acceptance and compliance are increased when crash detection systems are seamlessly integrated into the driving environment through easy controls.

It has been determined that the 18650 3.7 lithium-ion battery and the corresponding battery charging and step-up module are essential for the long-term functioning of these systems due to power supply issues. The literature highlights the necessity of dependable and durable power sources, especially in situations where conventional power delivery techniques may be impacted by vehicle crashes.

The practical features of the system, such as zero PCB boards, header pins for PCBs, and 10k ohm resistors, have been recognised for their contribution to the scalability and affordability of crash detection solutions. Research emphasizes the significance of easily available and reasonably priced components in promoting broad adoption, especially in areas where financial limitations can prevent the adoption of cutting-edge vehicle safety innovations.

Intelligent transportation systems (ITS) have advanced recently, with a focus on integrating many sensor technologies to improve crash detection capabilities. The advancement of sensor fusion techniques, which integrate information from several sources such as the GPS Neo 6m and MPU 6050 gyro sensor, has demonstrated potential in improving the precision and dependability of collision detection algorithms. This field of study investigates complex algorithms that take into account multi-dimensional data, enabling a more thorough comprehension of vehicle dynamics both during and following a collision event. By lowering false positives and negatives, these strategies hope to improve the crash detection system's ability to react to real emergencies.

3. Proposed Method:

3.1 Problem statement

Motorcycle transportation is widely recognized as one of the riskiest modes of travel globally. A survey conducted by the National Highway Traffic Safety Administration reveals a concerning statistic: approximately 212.7 deaths are reported for every 100 million Vehicle Miles Traveled (VMT) on a motorcycle. Despite notable safety advancements over recent decades, motorcycles continue to account for a disproportionate number of fatalities in the transportation sector, making motorcycle accidents a prevalent concern.

In the United States alone, motorcycles constituted 3% of all registered vehicles in 2019, yet motorcyclists represented a staggering 14% of all traffic fatalities, as reported by the National Highway Traffic Safety Administration. This resulted in an estimated 84,000 motorcyclists sustaining injuries in accidents that year. While motorcycles inherently pose significant risks, a noteworthy finding is that many fatal accidents, involving both cars and motorcycles, occur during left turns.

This paper addresses the critical need to detect motorcycle crashes, validate the legitimacy of the crash to avoid false positives, and subsequently alert designated emergency contacts with precise details regarding the crash's location and time. Such information empowers the receiver to promptly notify the relevant authorities and provide essential assistance. Additionally, it facilitates quicker response times for individuals in proximity to the crash site who can assess the situation firsthand.

The proposed solution utilizes the MPU 6050 sensor, a multi-axes accelerometer and gyroscope, to detect when a motorcycle has toppled over, indicating a crash. In the event of a fall, the system updates the position status on the Firebase database, which is then accessed by the rider's smartphone. The smartphone extracts the location's latitude and longitude, transmitting crash details to the pre-configured emergency contacts through the dedicated app. To address potential false alerts, the system incorporates a button allowing the rider to quickly disable the notification.

This innovative approach aims to enhance motorcycle safety by leveraging advanced sensor technology, real-time data transmission, and efficient communication with emergency contacts, ultimately contributing to reducing the severity and consequences of motorcycle accidents.

3.2 Objectives

- Design and develop a comprehensive vehicle crash detection and alert system by integrating the TTGO T-Call Sim8001 ESP32 module, Airtel Sim card, GPS neo 6m, and MPU 60 50 gyro sensor with an emphasis on seamless interoperability.
- Investigate and implement machine learning or advanced signal processing techniques to discern genuine collision events from false positives, optimizing the system's ability to promptly and accurately detect accidents.
- Evaluate the energy efficiency of the crash detection system, exploring sleep mode configurations and other power-saving techniques to enhance sustainability and minimize the environmental impact of the system's operation

3.3 Phases

There are several phases that the program runs through every time it is powered on

Phase of Initialization:

- Goal: To configure and prepare the system's component parts for use. Actions: Set up wireless communication by initializing the TTGO T-Call module.
- Configure the GPS module to gather precise location information.
- Set up the MPU6050 Gyro sensor to track the motion of the vehicle.
- Set up the push button and slide switch as well as other UI elements.
- To keep an eye on battery levels, configure power management.
- Set up your emergency alerts.
- Set up the data processing and handling components of the system.

2. Phase of the Power-On Self-Test (POST):

- Goal: Confirm the vital components working status.
- Actions: Make sure that communication is working properly by running a self-test on the TTGO T-Call module.
- Verify the GPS module's operation and capacity to deliver precise position information
- Check that the motion data readings from the MPU6050 Gyro sensor are accurate.
- Check the responsiveness of the slide switch and push button components of the user interface.
- Make that the battery management system has been properly initialized.

3. Phase of User Interaction:

- Goal: Allow users to engage with the system.
- Actions: Receive input from users via the User Interface.
- React to user requests, including turning on or off the system.

4. Phase of Continuous Monitoring:

- Goal: Constantly check vehicle parameters for possible collisions.
- Steps: Establish a loop for the real-time collection of sensor data.
- Check the push button and slide switch for user commands on a regular basis
- Keep an eye on power levels to make sure the system can run sustainably.

5. Phase of collision detection:

- Goal: To identify collisions by using sensor data.
- Steps: Examine MPU6050 Gyro sensor data to spot abrupt motion variations.
- Make use of GPS data to determine the position of the car and identify crashes.
- Start the emergency notification process as soon as a collision is detected.

6. Emergency Notification Phase:

- Goal: Initiate alert mechanisms in response to a collision.
- Actions: Activate the TTGO T-Call module for wireless communication.

- Send crash alerts and location information to predefined emergency contacts.

7. Phase of Post-Collision Handling:

- Goal: Control notification patterns and system behavior following a collision.
- Steps to take: Record the collision event for further use.
- Put in place redundancy checks for alerts about emergencies.
- Depending on the user's preference, handle system shutdown or carry on with monitoring.

3.4 Architecture:

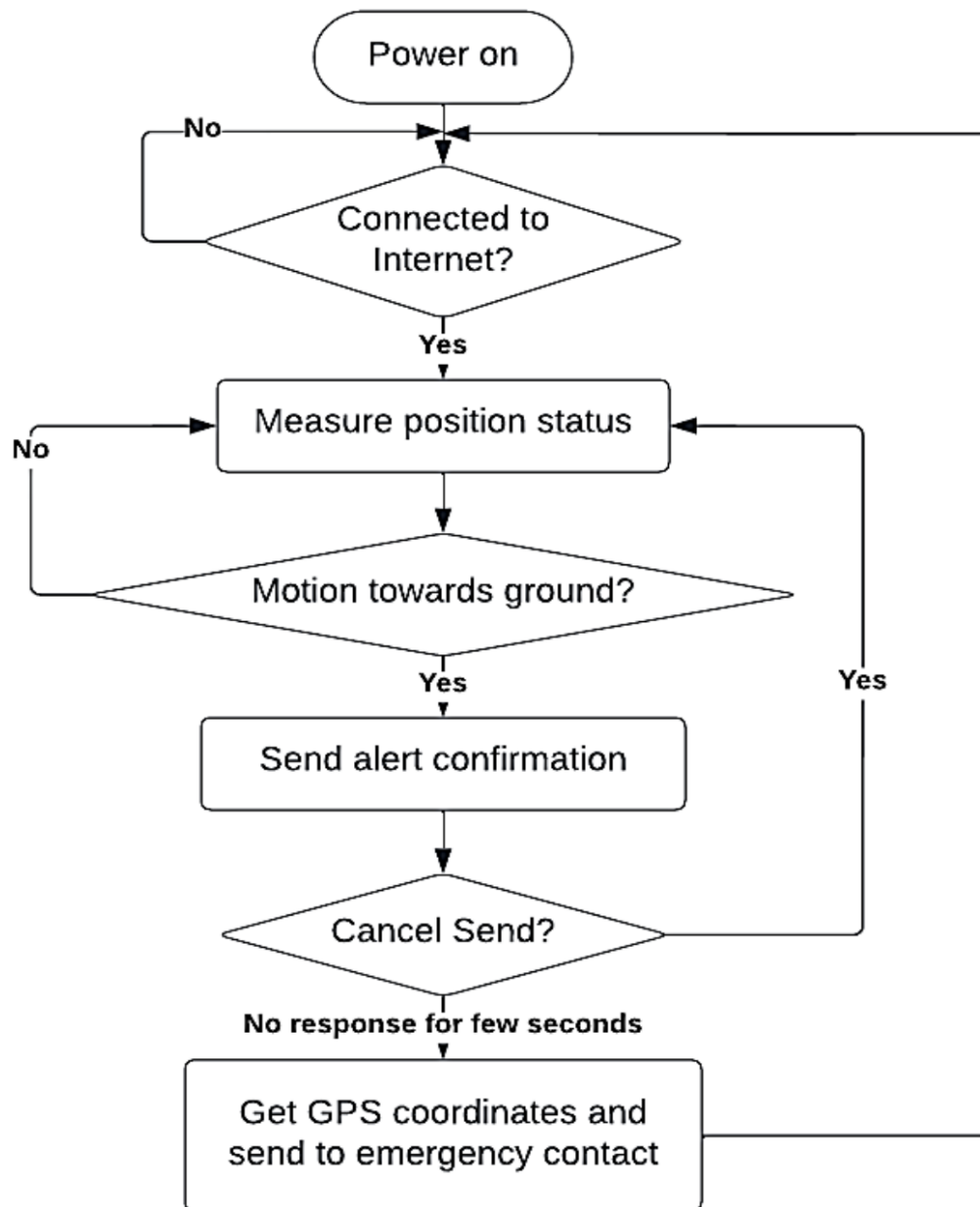

4.Experimental Results:

The use of the Arduino IDE's Serial Plotter was integral in comprehensively evaluating the motorcycle crash detection system. Through graphical representation and meticulous analysis of real-time data, the system's capacity to accurately detect and respond to potential crashes was successfully validated, establishing a solid foundation for its practical application in enhancing motorcycle safety. By leveraging the Serial Plotter feature, the experiment not only verified the system's ability to identify crashes but also provided valuable insights into its responsiveness and adaptability. The graphical depiction of real-time data offered a clear and

intuitive understanding of how the system processed information, contributing to a comprehensive assessment of its overall accuracy and reliability.

Four different scenarios were plotted on the graph:

- A. Upright position maneuver (Traveling on road)
- B. Forward Crash maneuver
- C. Left-side Fall maneuver
- D. Right-side Fall maneuver

4.1 Graph for upright position

An observation has occurred here that the accelerometer readings barely change at all when the motorcycle is not crashed. So, when the motorcycle is in upright position, the a_x , a_y and a_z values only have a peak value of 0.3 during hard tilt on a curvy road. Otherwise, they're in a range of 0- 0.1 for most of the ride. The legends are as follows; • Blue curve - Y axis • Red curve - X axis • Green curve - Z axis

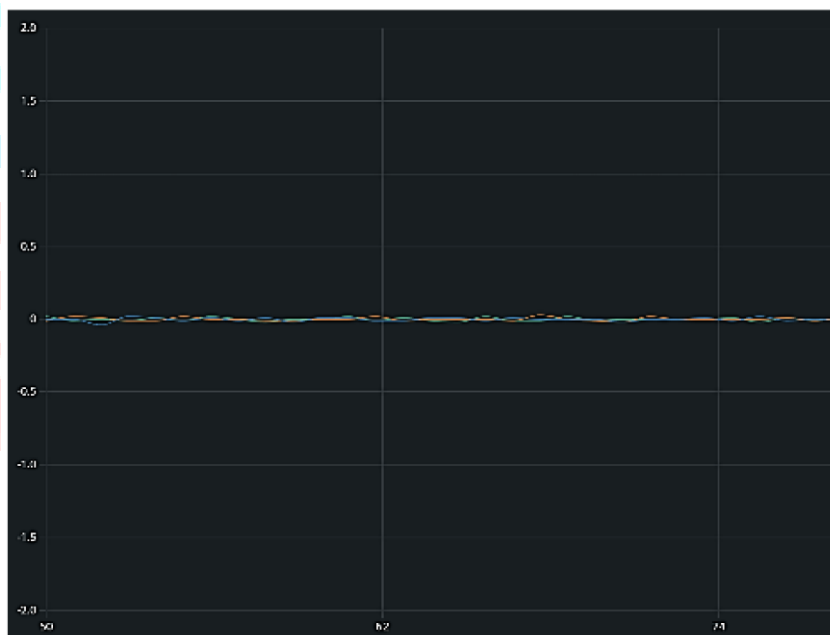

4.2 Graph for forward crash maneuver

Although the accelerometer reading in the y axis doesn't seem to cross a value of 0.5. This is because of the fact that the motorcycle never moved sideways during the entire event of the forward crash.

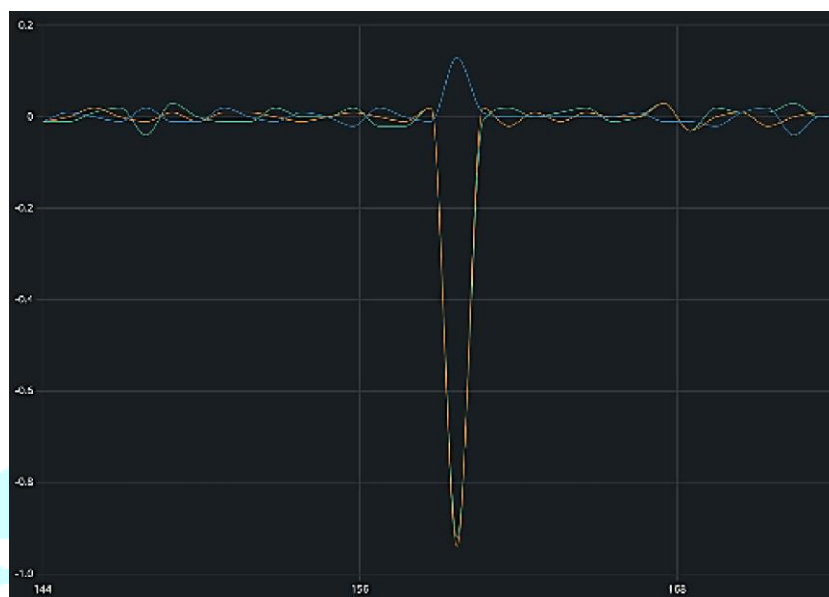

4.3 Graph for left side fall maneuver:

This graph shows how during a left side fall maneuver, the blue curve or the Y-axis curve as well as the green curve or the Z axis curve is showing a steep incline while the red curve or the X axis curve is in neutral position. This indicates that the motorcycle is moving in a positive y-axis or left direction in this demonstration. The green curve indicates the fall of the motorcycle in the maneuver.



4.4 Graph for right side fall maneuver

This graph shows how during a right side fall maneuver, the Y-axis curve as well as the Z axis curve is showing a steep incline while the red curve or the X axis curve is in neutral position.



5. Conclusion:

A significant stride in enhancing road safety has been achieved through the development and deployment of a vehicle collision detection and alarm system. This innovative system harnesses the capabilities of advanced technologies, including the TTGO T-Cal Sim 801 ESP32 Wireless Communication Module, Airtel SIM card, GPS Neo 6M, and MPU 6050 gyro sensor, complemented by various auxiliary components. The amalgamation of these cutting-edge features results in a robust system adept at efficiently monitoring vehicle trajectories, detecting collisions, and promptly dispatching alerts to pre-assigned emergency contacts.

Designed with user convenience in mind, the inclusion of elements such as the sliding on/off switch and push button ensures ease of use, aligning with the overarching goal of creating a practical and cost-effective solution. Furthermore, meticulous attention has been given to power management, facilitated by the 18650 lithium-ion battery holder, 3.7 lithium-ion battery, and the battery charging and step-up module.

This research delves into the operational intricacies of each component, elucidating the GPS module's real-time location data gathering and the MPU 6050's gyroscopic sensing capabilities. The systematic integration of these components into a cohesive framework, documented with clarity, substantiates the development of an intelligent and affordable solution to address concerns related to vehicle safety. The outcome of this research represents a significant stride in making roads safer through the implementation of smart and accessible technologies.

6. References:

1. J. Bonnells, J. De Gouveia, J. Reimers, B. Scherschel, Senior Design Group 22, University of Central Florida, Fall 2016 - Spring 2017, (2017)
2. 2. M. Kumari, S. Kumar, A. Kumar, N. Kumari, Int. J. of Sci. and Res. 9, 11, (2020)
3. 3. Automatic Motorbike Side Stand Slider, Available: Online: <https://nevonprojects.com/automatic-motorbike-stand-slider/>
4. 4. S. Parameswaran, P. Anusuya, M. Dhivya, A. Harshiya Banu, D. Naveen Kumar, Inter. J. of Engg. Res. & Tech. 4, 11, (2016)

5. TTGO T-Call SIM800L ESP32 Wireless Communication Module. (2022). GitHub Repository for TTGO T-Call SIM800L ESP32. Retrieved from <https://github.com/Xinyuan-LilyGO/TTGO-T-Call>
6. TTGO T-Call SIM800L ESP32 Wireless Communication Module. (2022). TTGO -T Call SIM800L ESP32 Wireless Communication Module Datasheet. Retrieved from [https:// github.com/Xinyuan-LilyGO/TTGO-T-Call](https://github.com/Xinyuan-LilyGO/TTGO-T-Call)

