



A REVIEW ON INVESTIGATION OF MECHANICAL PROPERTIES AND RECENT ADVANCEMENTS ON ULTRASONIC WELDING

¹SATHISHKUMAR S, ²PRANAYBABU K, ³NAVEENKUMAR K

¹RESEARCH SCHOLAR, ²PG STUDENT, ³PG STUDENT

¹Department of Production Technology,

¹Madras Institute of Technology, Anna University, Chennai, India

Abstract: The use of multiple materials in engineering structures is becoming more powerful, particularly in applications such as transportation. Combining different materials allows for more efficient designs and greater performance that could be achieved with a single material, with beneficial impacts for a range of industries. As it produces welds of high quality without the use of filler material, ultrasonic welding can join thin sheets of similar or different non-ferrous alloys, including copper, aluminum, magnesium, and brass. This bond is strong and reliable and can withstand high loads and stresses. These studies evaluate the relationship between the tensile strength of ultrasonic welding of sheets with various welding parameters, such as weld pressure, weld time, and hold time. It has been discovered that lengthening the weld and increasing the welding pressure can strengthen the link between the sheets. The mechanical characteristics of the joint, particularly its tensile strength and fatigue life, have been found to be improved by the application of an interlayer. A copper or zinc interlayer was shown to increase the joint's tensile strength. The enhanced mechanical capabilities are due to the interlayer's capacity to operate as a barrier between the sheets, limiting the production of intermetallic compounds and other flaws that could weaken the joint. This review article discusses the properties of ultrasonic welding, the interface of welding joints, performance, and welding variables for various materials.

Index Terms – Ultrasonic welding, parameters, interlayer, fatigue life, joint's tensile strength.

I. INTRODUCTION

Welding is a fabrication process whereby two or more parts are fused together by means of heat, pressure or both forming a join as the parts cool. Welding is usually used on metals and thermoplastics but can also be used on wood. The completed welded joint may be referred to as a weldment. Basically, welding may be classified into three types: Plastic welding: In plastic welding or pressure welding process, the pieces of metal to be joined are heated to a plastic state and then forced together by external pressure. These welding are also known as liquid-solid welding process. This procedure is used in forge welding and resistance welding.

Fusion welding: In the fusion welding or no pressure welding process, the material at the joint is heated to a molten state and allowed to solidify. These welding are also known as liquid state welding process. This includes gas welding, arc welding, thermite welding etc. Cold welding: In this welding process, the joints are produced without application of heat, but by applying pressure which results diffusion or inter-surface molecular fusion of the parts to be joined. It is also known as solid state welding process. This process is mainly used for welding nonferrous sheet metal, particularly aluminum and its alloys. This includes ultrasonic welding, friction welding, Explosive welding etc (Troughton M. J., 2009).

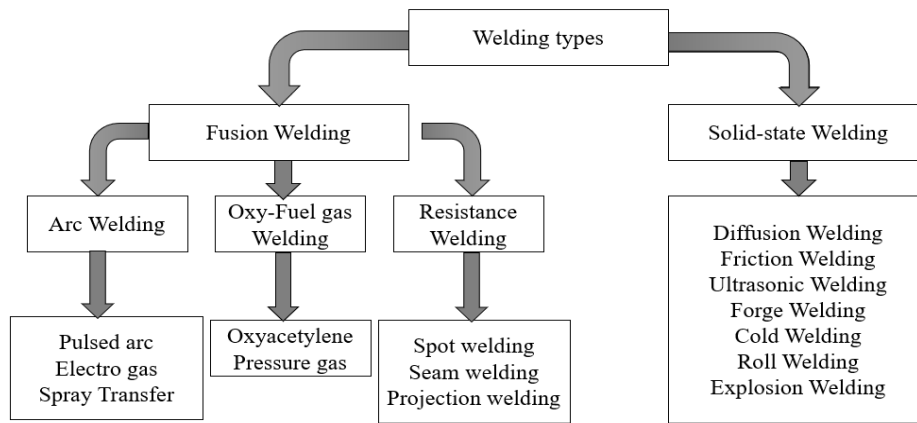
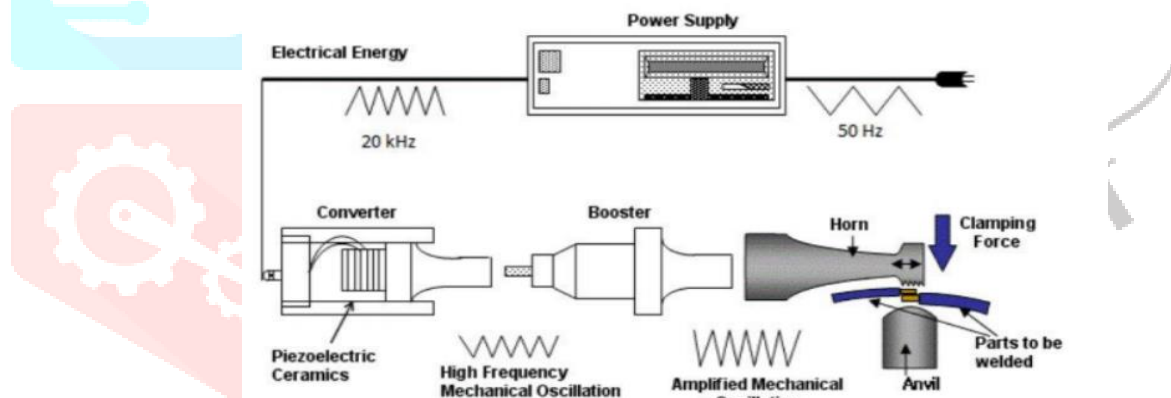

Figure 1. Types of Welding

II. ULTRASONIC WELDING

Ultrasonic welding is a type of solid-state welding as shown in Fig.1. Ultrasonic welding techniques have recently become extremely important in all industrial applications. Different metals and non-metals with varying melting points were treated using USW. This method makes it simple to fuse thin foil wires. With USW, high-quality welded joints can be produced without a protective gas shield. Ultrasonic welding (from Fig.2) is a widely used technique for joining metals and thermoplastics (Heinzle E. et al, 2006). The method employs ultrasonic vibrations at high frequencies of 20-40kHz and low amplitudes of 1-25 μ m to generate heat at the junction of the parts to be welded, causing the thermoplastics to melt, and become firmly attached upon cooling. This technique is known for its speed, with welding typically taking between 0.1 and 1.0 seconds (Davis J.R., 2003). The ultrasonic energy can also be used for reshaping thermoplastics and fitting metal sections in plastics to securely link dissimilar components. Ultrasound has been applied to steel joining



for over 60 years, enhancing grain refinement of fusion welds, and for brazing and soldering. The first steps towards the discovery of ultrasonic metallic welding (USMW) took place in the late 1940s when ultrasonic vibrations were applied to traditional resistance welding equipment at the Aero projects Company of West Chester, Pennsylvania. The goal was to decrease floor resistance in spot welding of aluminium (Liu J. et al, 2019).

Figure2. Illustration of Ultrasonic Welding System

III. WORKING PRINCIPLE OF ULTRASONIC WELDING

In the ultrasonic welding system (from Fig. 2) oscillation energy is supplied to the part to be welded by the welding tool, the so-called sonotrode. The very briefly occurring friction of the material particles causes the material to plasticise very quickly in the desired areas. The order of magnitude of the plasticizing depends upon the amount of ultrasonic energy supplied. Subject to proper application it is almost impossible for the materials to be altered or detrimentally affected in any way in areas outside the welding zone. Depending upon the type of plastic material, different solidification times are required "at the joint of plasticized material" to resolidify under the effect of the still present mechanical pressure. This process is called the cooling or holding time (Deekshant Varshney K., 2021). The USW systems utilize an in-process weld cycle in an effort to mitigate welding variability and stabilize weld quality, commonly done by measuring and controlling the electrical input to the transducer. Although it will be sufficient to control the speed of the sonotrode, it cannot provide detailed information regarding the forces at the weld interface and

their influence on weld quality. Besides, to address the root causes of weld variance, the electrical impedance of the transducer is determined by building overall representations of the system, displaying it as an equivalent electrical network (Tariq H., 2014). The relationship between this electrical entry impedance and the

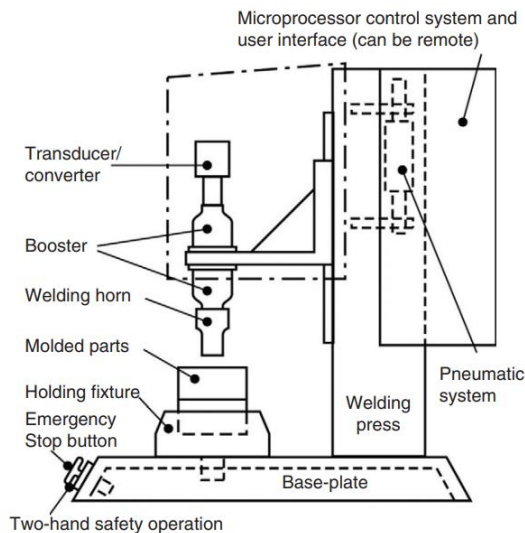

mechanical impedance at the weld is difficult to predict due to the many transfer elements like transducers, acoustic components and tooling that are situated between the welding system and the weld itself. Therefore, it is evident that, solely relying on the electrical input parameters to manage the welding process, does not guarantee optimal weld quality (Emamian S. R., and Mirzaei M., 2021).

Figure 3. Components in Ultrasonic Welding System

In the Ultrasonic welding machine (from Fig. 3), the sonotrode tip is brought into contact with the resonant part, allowing it to move freely within the required amplitude of oscillation. The ultrasonic pulse starts immediately. Once the right amount of plasticizing has happened where the parts meet, pressure increases to the selected level. This occurs rapidly and is completed just before welding. After the ultrasonic impulse ends, the force weakly increases, then a cooling phase starts; when it's finished, the machine returns to its original state, thus signalling the end of the welding process. The cycle takes a short duration. Therefore, complete welding process can take from 0.1 to 5 seconds, depending on the application (Macwan et al, 2015). The main components of ultrasonic welding systems are:

- i. **Sonotrode:** Depending on usage the following materials can be used; Titanium based alloy, hardened steel, special hardened steel and ferro-titanite.
- ii. **Sonotrode support ring:** The sonotrode support ring is made from brass and is used for support at the front of the resonance unit. All sonotrodes are fitted with a shrunk-on ring for the M4000 model.
- iii. **Booster:** The booster transforms the amplitude. There are different booster transmission ratios available. Which type you use depends largely upon the respective welding application and we will specify this on a case-by-case basis. A set screw connects the booster and sonotrode together.
- iv. **Booster support ring:** The shrunk-on booster support ring assumes the rear support function of the entire resonance unit.
- v. **Converter:** The mechanical ultrasonic oscillations are generated in the converter. The converter is encapsulated and can be air cooled if required.
- vi. **HF contact:** When the converter is installed, a spring-mounted element transfers the high frequency tension to the HF contact. The most important parameters to be considered in USW can be separated into system and materials parameters. The main system parameters are Welding time, Weld pressure, Hold time, Amplitude of vibration, Frequency, Electrical energy. The material parameters, including workpiece features, include Sample cleanliness (Oxides or Contaminants), Crystal structure, Dimensions, Hardness.

IV. METHODOLOGY

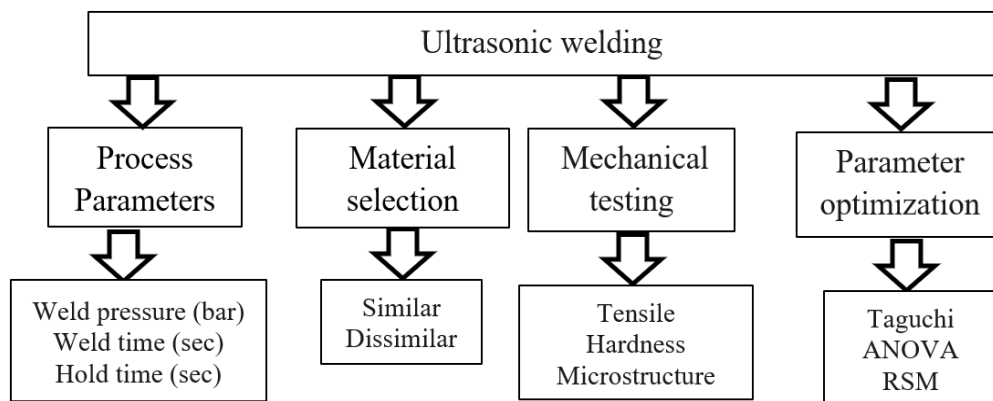

Figure 4. Methodology of Ultrasonic Welding System

V. ULTRASONIC METAL WELDING PROCESS

In this process, the two pieces of metal are joined by vibrating them around 20,000 cycles per second. The vibration causes the two pieces of metal to come into contact and generate frictional heat, which melts the surfaces of the two pieces, creating a strong weld. The main parameters used in this ultrasonic welding machine are: Welding time, Hold time, Weld pressure and Frequency and amplitude of vibration. Ultrasonic metal welding is a welding process that utilizes high frequency sound waves, rather than heat, to join pieces of metal together. suggested that based on the selected tabular array with welding parameters, the next step is to connect transducer, which is used to generate the high-frequency vibration during the welding process. The transducer then delivers ultrasonic energy and transforms the copper interlayer into a liquid, which helps to join the two metals together. Frictional heat is also generated by the vibrations, which can be adjusted to suit the welding requirements and allow for an effective weld (Chen et al., 2016). Finally, the joint is cooled down to a temperature that does not compromise the strength of the weld. This cooling process helps to solidify the weld and ensure that it has the necessary strength and integrity to withstand demanding applications. Ultrasonic welding process is based on the following four processes: Clamping, transmitting vibrations, Holding and Unloading.

Clamping: First, we must clamp the sheet materials to be welded on the anvil of the ultrasonic welding machine as a lap joint process. Clamp the sheets on the anvil tightly so that the sheets do not get disturbed by the vibrations transmitted from the Horn (Sonotrode) as shown in the Fig. 5.

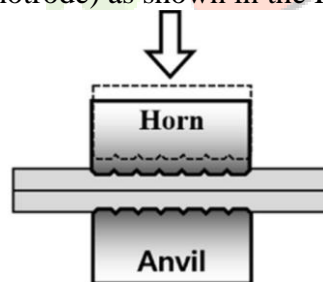

Figure 5. Clamping of sheet metals on the anvil

Transmitting Vibrations: After the clamping process, high frequency vibrations are transmitted from the sonotrode to the sheet material which clamped on the anvil. The pulse of energy causes the workpiece to undergo localized plastic deformation, leading to the formation of a joint as shown in the Fig. 6.

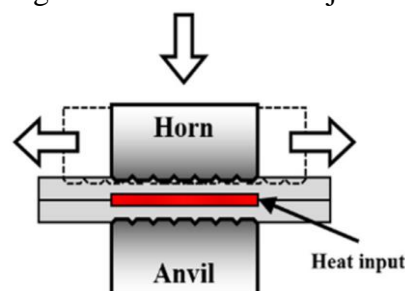

Figure 6. Transmitting Vibrations through the selected sheet metals

Holding: This holding process is followed by transmitting the high frequency vibrations to the sheet metals. In this process the horn exerts certain pressure over the sheet metals (from Fig.7) and it is held over the anvil for some time to create a strong joint between the two metal sheets. Then a weld nugget is formed.

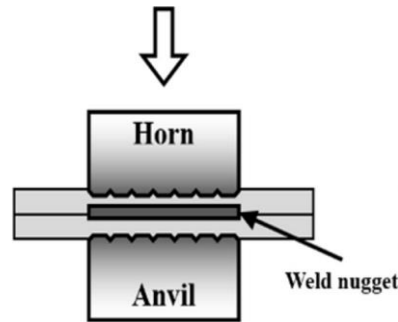

Figure 7. Holding of the ultrasonic welded sheet metals

Unloading/Unclamping: Finally, after the holding process, the Fig.8 shows that a strong weld nugget joint will be formed which forms indentation of the horn on the sheet metal. The weld formed between the two metal sheets forms an intermetallic compound (IMC's), the welded sheets will be unclamped by unscrewing the screw on the anvil.

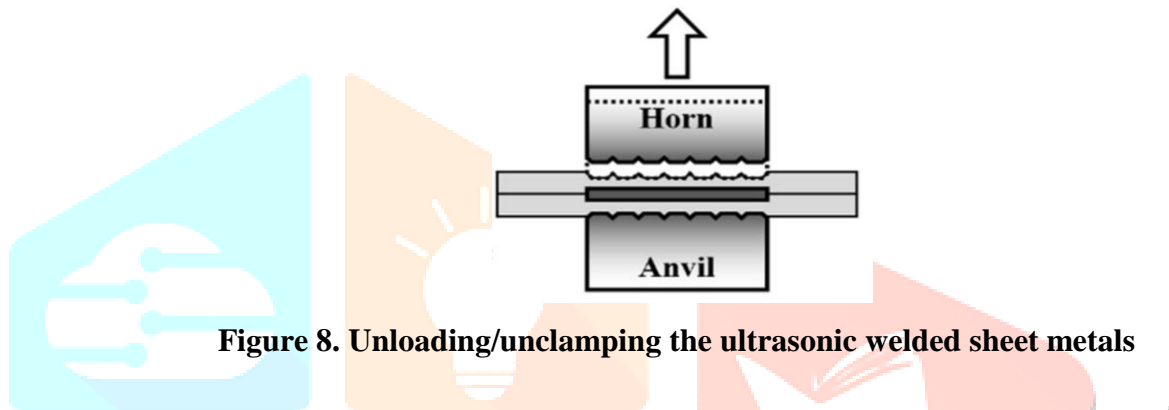

Figure 8. Unloading/unclamping the ultrasonic welded sheet metals

VI. EFFECT OF PROCESS PARAMETERS

To further enhance the weld strength, the three process parameters - pressure, time, and amplitude - should be optimized. As a result, not only will there be a reduction in the emission of pollutants, but the fuel efficiency of vehicles and aircraft could also be improved. The ultrasonic welding utilizes high-frequency vibrations with low heat input, the process being notably beneficial in the automotive, aerospace, appliance, and medical industries. This work investigated the influence of welding time, pressure, and vibration amplitude of 0.3 mm thick Copper sheets, by means of joint characteristics and shear strength. Analysis of variance revealed that the main factor impacting energy absorption is welding time, with pressure and amplitude proving influential also. Results indicated successful application of USW with most welds attaining a strength higher than the base material (Koen et al., 2023). It is explored that under optimal ultrasonic welding parameters (0.8 s welding time, 4 bar pressure, 62.4 μm amplitude), a joint with low gap fraction of 2.07% was obtained, and the maximum T-peel strength reached 432.9 N. Electron backscattered diffraction technology was employed to analyse grain boundary types and texture evolution. Continuous texture and copious amounts of large angle grain boundaries composed of high-density dislocations and substructure were observed in the bonding interfaces. The findings suggested that plastic deformation occurred in the bonding region and provided energy for the motion and rearrangement of dislocations, leading to the formation of new interfaces between the copper wires via recrystallization of the copper under high temperature. studied that high-power ultrasonic spot welding (USW) was employed to unify copper and AZ31B magnesium alloy with different welding energies as shown in Fig 9. Adhesion microstructure and durability of disparate associations were observed. The diffusion augmented throughout USW created an interface diffusion layer that was contrived of Mg and Mg_2Cu eutectic property. The diffusion layer breadth intensified with higher welding energy or temperature at the joint interface. A distinctive diffusion pattern occurred at maximum welding energy of 2000 and 2500 J, which was caused by an internal pressure that triggered the close eutectic liquid at hot spots are observed in Fig.10. The tensile lap shear strength raised during the beginning, reached an apex value, then fell as welding energy augmented. Connections created with optimal welding parameters of 1500 J and 0.75 s separated in the pattern of cohesive failure observed in the boundary diffusion layer's eutectic structure (Hajian S. et al, 2021).

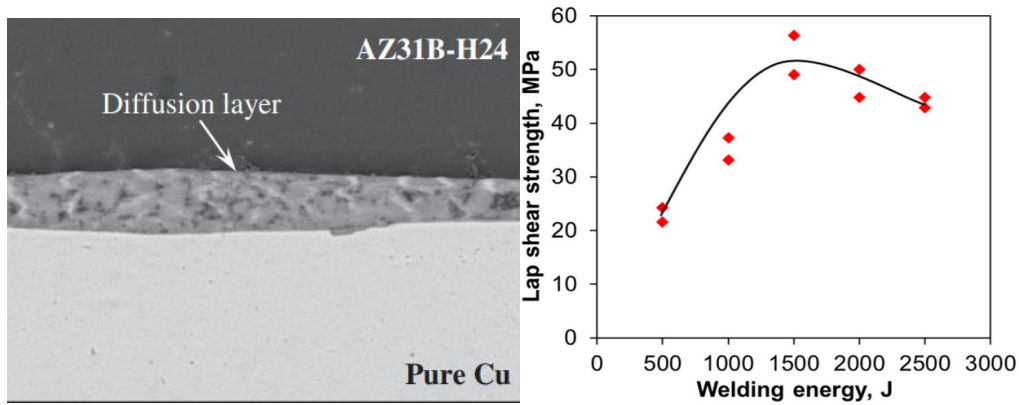

Figure 9. Image of ultrasonic welding of Mg and Cu and shear strength with respect to welding energy.

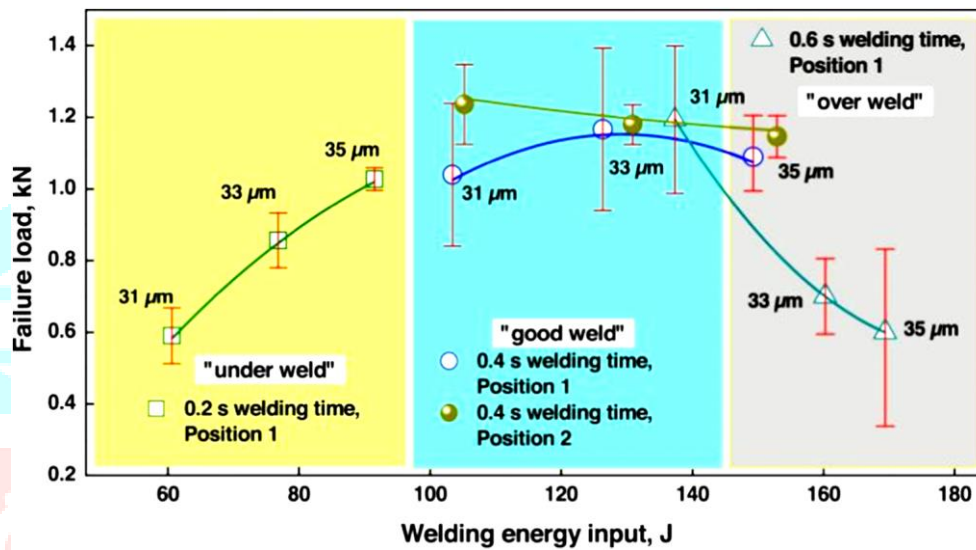

Figure 10. Effect of process parameters on joint tensile strength.

The use of welded structures made of AZ31B magnesium alloy and AA6061 aluminium alloy has become a popular means of constructing lightweight automobile body designs. In this paper, ultrasonic spot welding (USW) is experimented on to raise the strength of the joint. It is found from Fig.11 that with a welding energy of 1540 J, the joint starts to melt slightly. At the 1540 J energy level, there is a sudden surge in β phase which then greatly reduces the joint's performance. Upon inspection of the fracture, it is discovered to be a cleavage fracture that is accompanied by multiple secondary cracks (Zhanzhan et al, 2021).

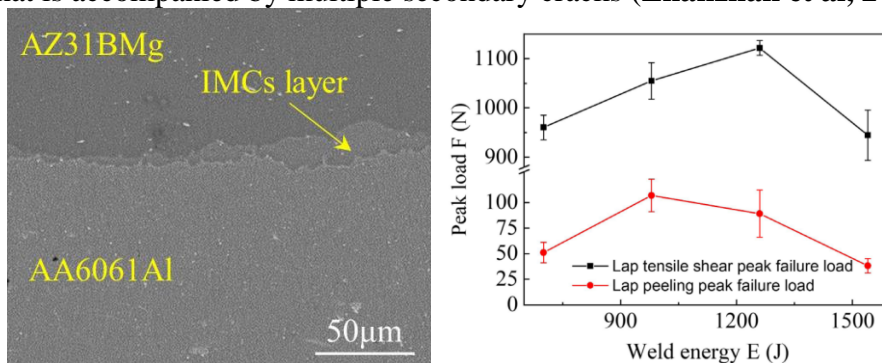

Figure 11. Image of ultrasonic welded Mg and Al sheet with formation of IMC

VII. EFFECT OF MATERIALS USED

The automotive and aerospace industries are increasingly turning to lightweight materials, such as **magnesium** and **aluminum** alloys, to manufacture components. The use of these non-ferrous metals like magnesium and aluminum alloy is increasingly becoming popular in industries dealing with marine, chemical metallurgy, and electronic appliances due to its high strength-to-weight ratio, excellent strength and rigidity, favorable cost, and easy machining characteristic. These materials have low density, great specific strength, decent damping properties, and can be cheaply cast. Ultrasonic welding is one of the most energy-efficient, solid-state joining techniques available, and it has been found to provide maximum weld strength (Felice R. et al, 2020). There are some critical problems and challenges going through to joining heavily responsible structural aspects in the automobile and aerospace industries, especially in the automobile industries for joining 5XXX and 6XXX sequence aluminum and in aerospace industries for joining the 2XXX, 6XXX and 7XXX aluminum. Because of the thickness and elastic vibrations of the parts, these challenges are faced. For the foils and wires, these challenges do no longer occur. The two key areas have emerged that hinder development from a realistic purpose standpoint. The first trouble is the sticking between the welded parts and the weld tooling. The second problem is that of various weld satisfaction when successive welds are made with what show up to be equal machine welding parameters (Basak S. et al, 2021), At first AA6061 introduced as "Alloy 61S", 6061 is an aluminum-alloy containing magnesium, silicon, and other elements. It is precipitation-hardened and has good strength, weldability, and extrusion properties. This alloy was developed in 1935. Applications: Aircraft, camera and marine parts, electrical connectors, decoration, hinges, magneto and brake components, hydraulic pistons, appliances, valves, bikes - all these items are suitable for fitting with the parts mentioned. Aluminum alloy 6061 is a medium-high strength alloy with better corrosion resistance and weldability than 6005A. Also, it has medium fatigue strength and good cold formability. 6061 aluminum is one of the 6xxx alloy types that use magnesium and silicon as primary elements (Zhang L. et al, 2021). stated that AZ31B is a formable and weldable magnesium alloy with good strength and ductility when used at room-temperature. Its versatility makes it suitable for diverse applications such as aircraft fuselages, cell phones, laptops, speaker cones and tools made from concrete. It can also be super formed at high temperatures, allowing it to produce intricate components used in the automotive industry. Additionally, it is not affected by high humidity and salt spray, making it an ideal choice for applications in marine environments (Jayasathyakawin S. et al, 2020).

VIII. EFFECT OF INTERLAYER USED

Ultrasonic spot welding of ZEK100-O Mg alloy to Al6022-T43 Al alloy with a Cu interlayer was successful, and various aspects of the process were examined. The Fig. 12. shows the ZEK100-O Mg alloy to Al6022-T43 Al alloy with a Cu interlayer in the middle of the sheets to be joined.

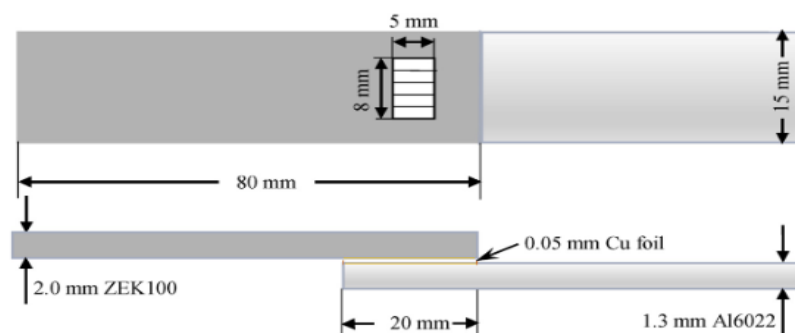
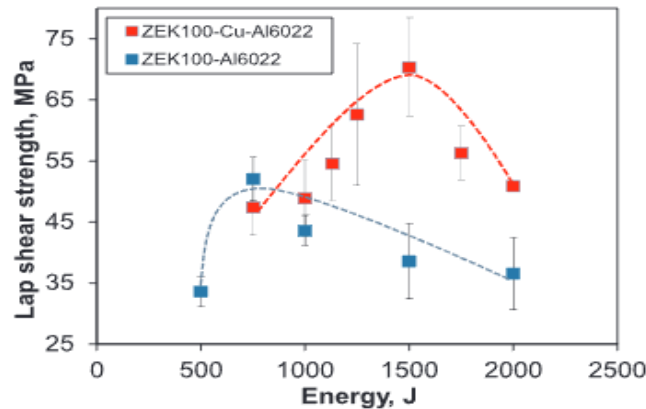

Figure 12. Image of ZEK100-O Mg and Al6062 alloy sheet with Cu interlayer

Microstructural analysis of Mg/Cu and Al/Cu interfaces revealed that while a diffusion layer formed at each interface, the Mg/Cu one was considerably thicker and composed of α -Mg and Mg₂Cu eutectic, while a thin layer of Al₂Cu and “barb”-like interlocks were found at the Al/Cu interface. Furthermore, the tensile lap shear strength increased with the welding energy reaching a peak value at 1500 J, reaching a level of 80% that of the strength of Al6022-Al6022 similar joints, and almost the same as ZEK100-ZEK100 similar joints,



with the addition of Cu interlayer resulting in 35% higher strength. From Fig.13. At the lower energy, failure was observed at the Al/Cu interface, while at the higher energy it occurred at the Mg/Cu interface (Peng et al, 2019).

Figure 13. ZEK100-Al6022 vs ZEK100-Cu-Al6022

The joining of the Mg/Al dissimilar metals was accomplished with ultrasound spot welding (USW) supplemented with a Zn interlayer (From Fig. 14). Here, we studied the layer formation, microstructure, mechanical properties, and fracture behaviour of the structures obtained when mating Mg/Zn/Al by USW. Results indicated that four distinct morphologies, due to the variable temperature and stress distribution, form the interface. The integration of a Zn interlayer checked the molecular diffusing of Mg and Al atoms, thus inhibiting the genesis of Mg-Al IMC. The formed Mg-Zn and Zn-Al structure gave satisfactory results and exhibited minor brittleness. The greatest shear force attained with Mg/Al joints USW with Zn interlayer was approximately 89.6% greater than those of ones without the interlayer (Xiaoyan et al, 2019).

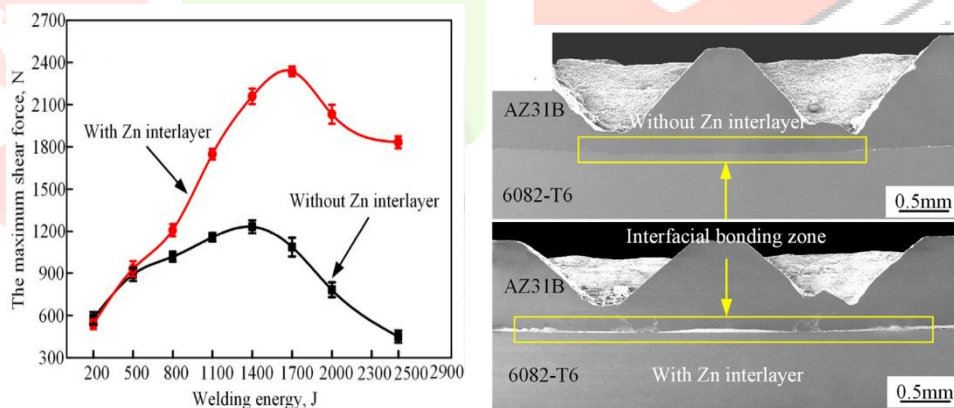

Figure 14. Image of joining of Al and Mg with Zn interlayer.

The incorporation of a Cu coating metallic interlayer in high-power ultrasonic spot welding (HP-USW) was studied for its weldability, joint strength, and its effect on the microstructure of AZ31B Mg alloy. Joints with the interlayer showed good weldability while requiring less energy, and their strength was comparable to joints without it (From Fig. 15) Temperature measurements, hardness data, and electron probe micro-analyzer (EPMA) results indicated the formation of Mg₂Cu in the interfacial regions. The changes in thermal and vibrational properties, grain structure, and the ternary alloy of MgCuxAl_y at the interface centerline suggest that this composited structure accounts for the joint strengthening (Chihiro et al, 2019).

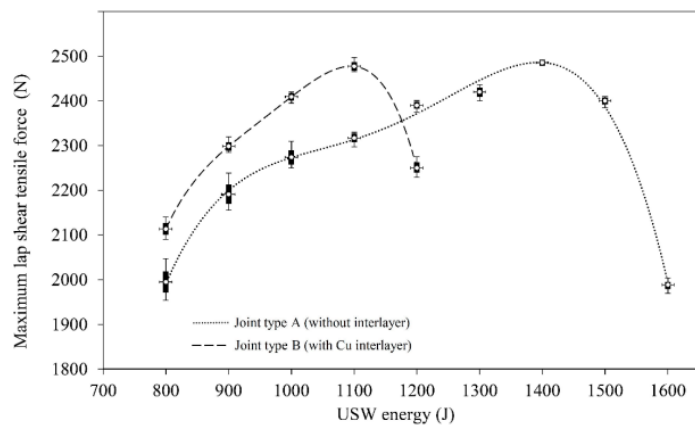

Figure 15. Image of comparative lap shear tensile force data vs energy, in high-power ultrasonic spot welding (HP-USW) of AZ31B, with and without interlayer (A: without interlayer; B: using Cu coating as interlayer)

The influence of gold coating and bare nickel interlayers on the microstructure and mechanical properties of aluminum-magnesium dissimilar resistance spot welds. Spot welds were performed with welding currents from 16 to 24 kA, with a fixed welding time of five cycles. Welds with bare nickel interlayers resulted in no joints; however, with the gold coating added to the nickel surface, resistances spot welds conforming to AWS D17.2 standards were created. The average lap shear strength of the welding compositions was almost 90% of the same of AZ-31B spot weld strengths. The fusion nugget size was evaluated, and the interfacial microstructure and fracture surface morphology were observed and recorded (Penner et al, 2013).

Ultrasonic welding with a copper interlayer between aluminum and magnesium metal sheets is a process used to join two or more metals together as shown in Fig. 16. It is an economical and efficient way to join two metals, particularly when the two metals have different melting points. Ultrasonic welding works by using high frequency vibrations to generate heat at the surface and quickly melt the copper interlayer, which in turn melts and bonds the two metals together (Singh P. et al, 2017).

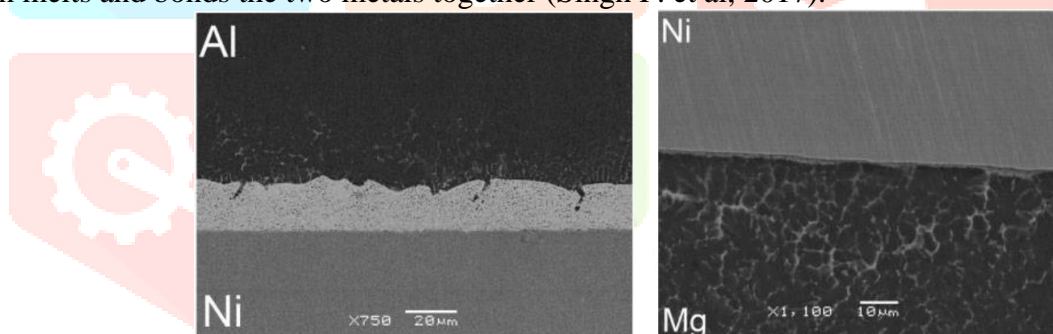

Figure 16. Image of Aluminium/nickel interface of weld (with Au coated Ni interlayer, 24 kA) and Magnesium/nickel interfaces in weld (with Au coated Ni interlayer, 24 kA)

The copper interlayer acts as a heat conductor and provides a strong bond between the aluminum and magnesium metal sheets. It also helps to prevent galvanic corrosion, which can occur when two dissimilar metals are joined together. The copper interlayer also helps to absorb shock and vibration, making the welded joint more durable and less prone to fatigue and cracking. An important consideration when using a copper interlayer during ultrasonic welding is the sheet thickness of each substrate. The sheet thickness of the substrate should be kept as close to that of the copper interlayer as possible, or thinner, if possible, to ensure an effective weld. If the sheet thickness of the two work pieces is significantly different, it can lead to an incomplete weld and a joint that is not as strong which expected to be (Chihiro et al, 2019).

Pure copper is an ideal interlayer material for ultrasonic welding due to its excellent mechanical properties. It has good electrical and thermal conductivity, making it ideal for use in applications where heat and electricity must be transferred quickly and efficiently. Copper also has high levels of ductility and malleability, meaning it can be easily bent and stretched into different shapes without fracturing. Pure copper also has excellent corrosion resistance and is resistant to abrasion, making it ideal for use in environments where exposure to corrosive chemicals or abrasive surfaces is likely. Additionally, copper is highly resistant to fatigue, meaning it can handle repeated stress without cracking or breaking. Another important point to consider when using copper as an interlayer is its ability to form an alloy with other materials. When the copper is subjected to vibrations from the transducer, it will form a liquid, allowing it to fuse with the two

metals being welded together. This process helps to promote an even and complete weld, improving weld strength and joint integrity (Farzami F. et al, 2019).

IX. ADVANCED ULTRASONIC METHODS

The successful low-temperature joining process of 6061-T6 Al and AZ31B Mg alloys via ultrasonic assisted friction stir welding (UaFSW). The joints exhibited smooth surfaces, due to the stationary shoulder obtained with a rotational velocity of 1000 rpm, 80 mm/min welding speed, and 1400 W ultrasonic power, which enhanced material flow. The joining interface, consisting of Intermetallic compounds, such as Al_2Mg_3 , was derived from the inter diffusion caused by the plastic deformation from friction stirring and ultrasonic processes. The tensile strength and elongation of the Al/Mg joint, however, were found to be 134 MPa and 1.5%, respectively from the Fig. 17; the main factor leading to the fracture being the IMCs formed in the Stir Zone. Thus, the current study implies that UFSW offers potential for joining Al/Mg alloys at low temperature, providing useful insights for dissimilar materials welding (Zhenlei et al., 2018).

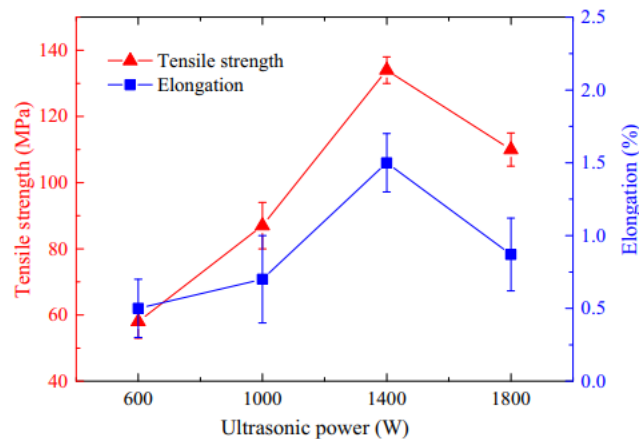

Figure 17. Image of Tensile property of UaFSW joints

New welding method of combining non-ferrous metals, resistance heat assisted ultra-sonic welding, is suggested. Electric Joule effect is employed as an additional electrical energy source to support ultrasonic welding. From the Fig. 18. It shows that the Resistance heat assisted ultrasonic welding and ultrasonic welding are compared between two dissimilar Al-Cu connections. This process heightens the towering power of ultrasonic vibration significantly. Study of the reaction between aluminum and copper through function of the current occurs. Thickness of intermetallic compound layer, mainly made up of CuAl_2 , rises with increasing current. At relatively strong current (1500A), dendritic solidification microstructure at connectors' interface emerges due to the eutectic reaction $\alpha\text{-Al} + \theta \rightarrow \text{L}$ happening in welding procedure. Influence of electric current on mechanical elements of the joints is described (Jingwei et al, 2021).

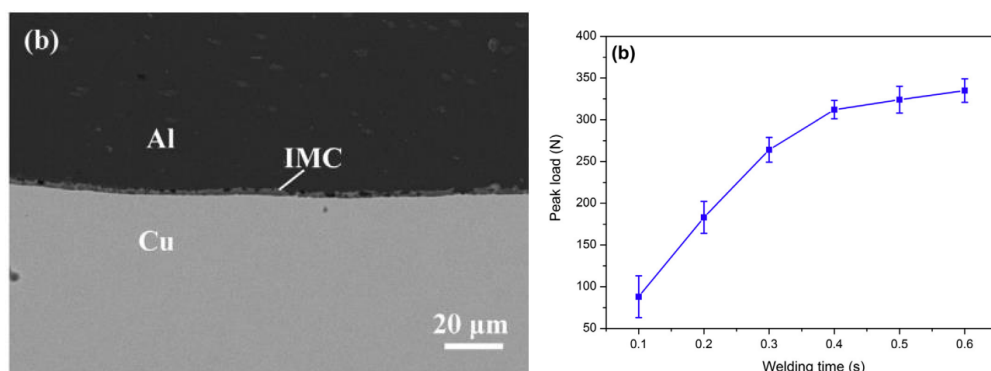

Figure 18. Image of resistance assisted ultrasonic welded Al and Mg alloy sheets with formation of IMC

To increase efficiency, a process called high-power ultrasonic spot welding has been used to successfully join a 1 mm gauge 6111 aluminum to a DC04 steel automotive sheet. Results of lap shear tests showed that the maximum failure load of the joint was 2.8 kN, which is comparable to an Al-Al joint at 2.9 kN. The factors determining joint characteristics and microstructure evolution in the welds are discussed. Low peak temperature is advantageous for minimizing the quantities of IMCs in Al/Mg alloys with different FSW, but it can easily cause inadequate material flow, which then causes a hollow or even a groove fault. The drawbacks were removed using the UaFSW approach. UaFSW was successfully employed to combine 6061-T6 Al and AZ31B Mg alloys based on the stationary shoulder, realizing high-speed welding at low temperature (Zhenlei et al., 2018).. It shows that at 1000 rpm, 80 mm/min, and 1400 W, a sound joint free of shoulder marks was attained. IMCs at the joining interface, which was characterized by inter diffusion, were due to the extreme plastic deformation brought on by ultrasonic and friction stirring. The Al/Mg joint's tensile strength and elongation both exceeded 134 MPa and 1.5%, respectively (Prangnell et al, 2011).

X. CONCLUSION

Ultrasonic Welding can lead to the development of new techniques and equipment, which can enhance the performance, reliability, and cost-effectiveness of the process. Additionally, understanding the science behind ultrasonic welding can help researchers optimize the process for specific materials and applications, leading to improved quality and performance. There is a need to study Ultrasonic Welding due to its numerous advantages, such as the ability to join different materials, high production rates, and low energy consumption. It is widely used in the automotive, electronics, medical device, and packaging industries, among others. Ultrasonic metal welding is a solid-state welding process that utilizes high-frequency vibrations to join two metal pieces together. Unlike traditional welding methods, ultrasonic metal welding does not require the use of heat or any external filler material. Instead, the process relies on mechanical energy to create a strong bond between the two metals. some of the advantages of ultrasonic metal welding are: High Precision, Strong Welds, Cost-Effective, No Heat Distortion, Environmentally Friendly, Versatility.

REFERENCES

- [1] Akbari A., Gholami S., and Rezaei M., (2021), 'Microstructure and mechanical properties of ultrasonic spot welded AA6061 aluminum alloy sheets', *Journal of Materials Research and Technology*, Vol. 10, pp. 1085-1094.
- [2] Basak S., and Kumar S., (2021), 'Experimental Investigation on Ultrasonic Welding of Similar and Dissimilar Thermoplastics: A Review', *Polymers and Polymer Composites*, Vol.29, pp.289-307.
- [3] Chen D., Gao L., Liu H., Wu Y., and Xu L., (2016), 'Investigation of the joint properties of ultrasonic spot welded AZ31B magnesium alloy to AA6061 aluminum alloy', *Journal of Materials Processing Technology*, Vol. 229, pp. 65-72.
- [4] Chihiro I., Amir B., Shigeo S., and Suguru T., (2019) 'Interface Characterization of Ultrasonic Spot-Welded Mg Alloy Interlayered with Cu Coating', *Metals*, Vol.9, pp.1-18.
- [5] Davis J.R., (2003), 'Handbook of Aluminum', *Physical Metallurgy and Processes*, 1st edition, Vol. 1, pp.26-38.
- [6] Deekshant Varshney K., (2021), 'Application and use of different aluminium alloys with respect to workability, strength and welding parameter optimization', *Ain Shams Engineering Journal*, Vol. 12, pp. 1143-1152.
- [7] Emamian S. R., and Mirzaei M., (2021), 'Effect of ultrasonic welding parameters on the microstructure and mechanical properties of AZ31B magnesium alloy sheets', *Materials Science and Engineering: A*, Vol. 809, pp. 111953.
- [8] Faes K., (2023), 'Influence of the Process Parameters on the Properties of Cu-Cu Ultrasonic Welds', *Journal of Manufacturing and Materials Processing*, Vol.7, pp.19.
- [9] Farzami F., Naseri M., and Sadeghian Z., (2019), 'Microstructure and mechanical properties of ultrasonic welded joints of AZ31B magnesium alloy to AA6061 aluminum alloy with copper interlayer', *Journal of Manufacturing Processes*, Vol.40, pp.123-132.
- [10] Felice R., Hetal P., Vitantonio E., and Pierpaolo C., (2020), 'Ultrasonic welding of magnesium alloys: a review', *Materials and Manufacturing Processes*, Vol.35, pp.1051-1068

- [11] Ghobadi R., Yavari M., (2021), 'Effect of welding parameters on the microstructure and mechanical properties of ultrasonically welded AZ31B magnesium alloy sheets', *Journal of Materials Research and Technology*, Vol. 10, pp. 2181-2191.
- [12] Hajian S., Hosseini S.M., Mahmoodi M., and Moslemi Naeini H. (2021), 'Effect of welding parameters on mechanical and microstructural properties of ultrasonic spot welded AA6061 aluminum alloy sheets', *Journal of Materials Research and Technology*, Vol. 10, pp. 1208-1218.
- [13] Heinzle E., Wilhelm A., and Schmachtenberg H., (2006), 'Ultrasonic welding,' in *Plastics technology handbook*, C. L. Beatty, Ed. New York: CRC Press, pp. 389–396.
- [14] Jayasathyakawin S., (2020), 'Mechanical properties and applications of Magnesium alloy – Review', *Materials Today: Proceedings*, Vol. 27 Part-2, pp. 909-913.
- [15] Jilin Xie W., (2021), 'Microstructure and mechanical properties of ultrasonic spot welding TiNi/Ti6Al4V dissimilar materials using pure Al coating', *Journal of Manufacturing Processes*, Vol. 64, pp. 473-480.
- [16] Jingwei Y., Biao C., (2021) 'Investigation of resistance heat assisted ultrasonic welding of 6061 aluminum alloys to pure copper', *Materials Research*, Vol.74, pp.19-24.
- [17] Liu J., Huang Y., and Sun S., (2019), 'Research progress on joining of aluminum alloys for automotive body', *Journal of Materials Engineering and Performance*, Vol.28, pp.5417-5426.
- [18] Macwan A., Jiang X.Q., And Chen D.L. (2015), 'Microstructure and mechanical properties of ultrasonic spot welded copper-to-magnesium alloy joints', *Materials & Design*, Vol.84, pp. 261-269.
- [19] Michael DL, Seop SH. (2016) 'Weldability assessment of Mg alloy (AZ31B) sheets by an ultrasonic spot-welding method', *Journal of Materials Processing Technology*, Vol.243, pp. 1–8.
- [20] Peng H., (2019), 'Ultrasonic spot welding of magnesium-to-aluminum alloys with a copper', *Journal of Manufacturing Processes*, Vol. 37, pp. 91-100.
- [21] Penner P., Liu L., Gerlich A., and Zhou Y. (2013) 'Feasibility study of resistance spot welding of dissimilar Al/Mg combinations with Ni based interlayers', *Science and Technology of Welding and Joining*, Vol.18, pp.541-550.
- [22] Prangnell P., Haddadi F., and Chen Y. C. (2011) 'Ultrasonic spot welding of aluminium to steel for automotive applications—microstructure and optimisation', *Materials Science and Technology*, Vol.27, pp.617-624.
- [23] Singh. P, Gupta R. K., Shandilya A., and Singh K., (2017), 'Ultrasonic welding of aluminum to magnesium: Influence of copper interlayer', *Materials Science and Engineering: A*, Vol. 680, pp.1-8.
- [24] Sun S., Huang Y., and Liu J., (2019), 'Research progress on joining of aluminum alloys for automotive body', *Journal of Materials Engineering and Performance*, Vol.28, pp.5417-5426.
- [25] Tariq H., (2014), 'Effect of ultrasonic welding parameters on microstructure and mechanical properties of dissimilar joints', *Materials & Design*, Vol. 55, pp. 263-273.
- [26] Troughton M. J.,(2009), 'Handbook of Plastics Joining(Second Edition)', Elsevier Inc., pp. 15-35.
- [27] Xiaoyan G., Chenglong S., Jing L., Donglai L., Zhengyu M., and Kaixuan Z. (2019) 'Microstructure and mechanical properties of Mg/Al joints welded by ultrasonic spot welding with Zn interlayer', *Materials & Design*, Vol.181, pp. 108103.
- [28] Zhang L., (2021), 'Recent advances in welding aluminum alloys for aerospace applications: A review', *Journal of Materials Science & Technology* Vol.52, pp.23-44.
- [29] Zhanzhan S., Zhengqiang Z., Yifu Z., Hua Z. (2021) 'Analysis of Microstructure and Mechanical Properties of AZ31B Magnesium Alloy/AA6061 Aluminum Alloy Welded Joint by Ultrasonic Welding', *Materials Research*, Vol.24, pp.2.
- [30] Zhenlei L., Shude J.& Xiangchen M. (2018) 'Joining of magnesium and aluminum alloys via ultrasonic assisted friction stir welding at low temperature,' *International Journal Advanced Manufacturing Technology*, Vol.97, pp.4127–4136.