



SMART LIBRARY MANAGEMENT SYSTEM

¹K.Swathi, ²Mahitha Tenneti, ³Jillela Shruthi, ⁴Chinnala Anusha, ⁵Palwai Shloka

¹Assistant Professor, ²Student, ³Student, ⁴Student, ⁵Student

Electronics and Communications Department,

G. Narayanamma Institute of Technology and Science, Hyderabad , India

Abstract: The library plays a crucial role in education, and its staff often face tedious tasks such as lending, and tagging books. Library users also encounter problems such as finding, borrowing, and renewing books. To overcome these obstacles, a proposed smart library management system based on RFID scanning can make the library experience more convenient and practical for both users and staff. The system will integrate ID cards into the library management process, automating many tasks such as borrowing and returning books. This will make it easier for users and staff to manage their workloads more efficiently. The project is motivated by several challenges faced by the current library system, such as loss of book information, slow transaction processing, and difficulty in updates.

The proposed library management system has a feature where the login and logout timings of students or faculty members are posted onto the Thingspeak server of the IoT cloud. This feature helps in maintaining a record of the entry and exit times of the students or faculty members, which can be useful in tracking their activity in the library. The data stored on the Thingspeak server can be accessed remotely and can be used for generating reports, analyzing usage patterns, and making informed decisions about the library's operations. This feature enhances the transparency and accountability of the system and ensures that the library management can keep track of the library's activity even when they are not physically present.

The system has a significant feature where it sends a text message to the registered mobile number if the due date for returning the book has passed. This feature ensures that the students or faculty members are reminded about the book they borrowed and prompts them to return the book within the stipulated time. This is a very important feature as it helps in maintaining the discipline of returning books on time and avoids fines or penalties. Moreover, it also helps in ensuring the availability of books for other students who need them. This feature makes the system more efficient and user-friendly, making it an ideal solution for library management.

Additionally, the system will include automation for fans and lights, reducing electricity waste. The proposed system, which utilizes Arduino sensors and a GSM module, will help overcome these problems and provide a smarter, more useful library management system. Overall, the proposed system aims to enhance the library experience for both staff and users, providing a more efficient and effective approach to library management.

Index Terms- *RFID scanning, managing workloads, Thingspeak server, Due date reminder, Reducing electricity wastage.*

I. INTRODUCTION

The library is a crucial resource for learning and education, as it provides access to a vast collection of books and information resources. However, traditional library systems often face problems such as inefficient management of book records, slow processing times, and high-power consumption.

To address these challenges, a proposed library management system using RFID technology can offer several benefits. RFID tags and readers can automate the process of issuing and returning books, reducing the workload on staff and providing more accurate and up-to-date information of book. Additionally, the system can automatically turn off lights and fans when not in use, reducing energy consumption and costs.

With the new system, library staff can work more efficiently and effectively, providing better service and support to students and faculty members. By automating the process, staff can spend more time on other critical tasks, such as organizing the library and helping patrons to issue/return the books they need. The proposed system can also provide real-time updates on login/logout timings, allowing staff to make data-driven decisions to improve library services.

II. PROBLEM DEFINITION

One of the major issues in today's library systems is the lack of accurate information regarding book issuance and return. To address this problem, a proposed smart library management system utilizing RFID tags and readers can be implemented. The system can automatically scan the tags and display the book's name and author on an LCD display, eliminating the need for manual entry by library staff. The system is powered by a +5v DC supply, requiring no human intervention for its operation.

Another problem faced in libraries is the wastage of electricity due to fans and lights being left on even when the library is empty. The proposed system can address this issue by automating the operation of fans and lights, turning them off when no one is present in the library. Overall, implementing this smart library management system can enhance the library experience by improving the accuracy of book records and reducing unnecessary energy consumption.

III. FORMULATION OF OBJECTIVES

The proposed project has several objectives that aim to improve the current library management system.

1. To eliminate the manual process of updating book status in the registers, which can be time-consuming and prone to errors. This will be achieved by using technology such as the EM18 module, PIR sensor, and LM35 temperature sensor, which will be interfaced with the Arduino UNO.
2. To send text message to the registered mobile if the due date of the book has been completed.
3. To display the book's issued/returned status on the LCD screen, which will provide users with real-time information and reduce the workload of library staff.
4. Posting the login/logout details of the students/faculty into the thingspeak cloud.
5. Additionally, the system will include automation of lights and fans to reduce electricity wastage, which is a common problem in many libraries.

By implementing these objectives, the proposed system aims to improve the library experience for both staff and users, making it more efficient, convenient, and practical.

IV. LITERATURE SURVEY

These three research papers focus on different approaches to implement smart library management systems using modern technologies.

Nisha Patil, Pallavi Karande, Jayshree Desai, Sheetal Pereira, "Internet of Things for library Management System" International Journal of Engineering Science and Computing, April 2017, discusses the use of NFC tags on books and user cards, along with separate hand-held readers and user smart phones to access library data remotely [6].

Mrs. Vandana C. P., "Library Management system based on IoT" Volume-3, Issue-4, April, 2017 Paper-17 emphasizes the need for a user-friendly library system that also optimizes employee time and energy, which can be achieved through IoT implementation [5].

Chetan J. Jadhav, Shivani S. Jadhav, "Smart Library Management System Using RFID Technology" International Research Journal of Engineering and Technology (IRJET) Volume: 04 Issue: 05 May – 2017, this paper proposes an RFID-based system that facilitates fast and efficient book transactions, utilizing RFID readers and passive tags to store and retrieve book information [2]. Overall, these papers showcase the potential of technology to improve library management and operations, providing benefits such as reduced manual intervention, increased efficiency, and greater convenience for library users.

V. EXISTING SYSTEM

The current library management system is inefficient, complex, and requires a lot of manual effort by staff. The system is also not very accurate in keeping track of issued and returned books, which can cause problems for both staff and students.

Additionally, the current system is slow and time-consuming, leading to long waiting times and discouraging some students from using the library. To address these issues, a smart library management system can be implemented to automate processes, reduce manual work, and provide more accurate and efficient tracking of books. This can improve the overall user experience for both staff and students and lead to a more streamlined and effective library system.

VI. PROPOSED SYSTEM

The proposed system can be visualized through the block diagram i.e shown in below Fig. 1. The system consists of various components such as EM18 module, PIR sensor, LM35 temperature sensor, relays, lights and fans, LCD display and an Arduino UNO.

The EM18 module is used for detecting the presence of RFID tags on the books, while the PIR sensor detects the presence of users. The LM35 temperature sensor measures the temperature of the library environment, and the relays are used to control the lights and fans automatically to save electricity. The LCD display is used to show the status of the books whether they are issued or returned. The Arduino UNO acts as the main controller that receives data from all these components, processes it, and provides the necessary output. The proposed system is designed to reduce the workload of the staff, increase the efficiency of the library system, and provide a better user experience for students.

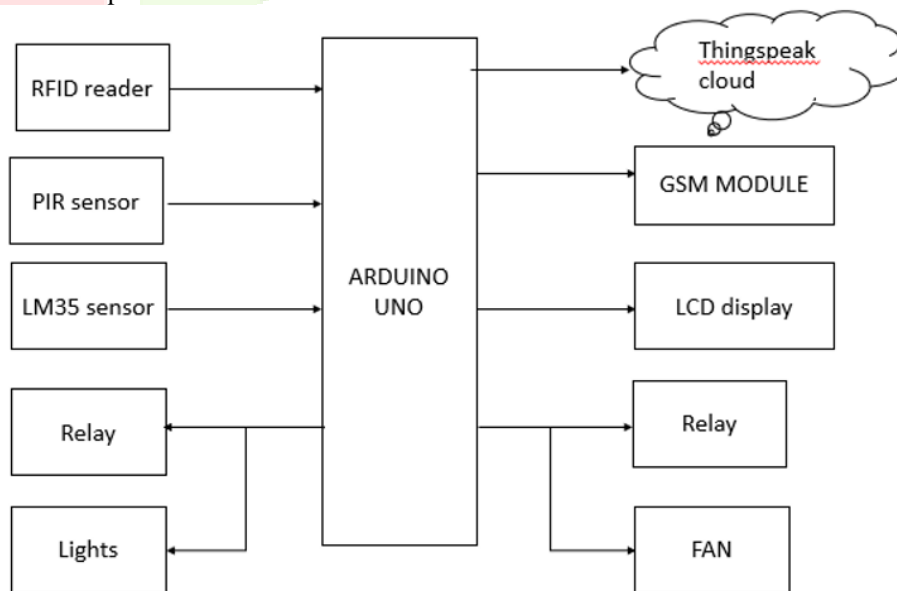

Fig. 1 Block diagram of proposed system

The proposed system is a combination of both software and hardware that aims to improve the management of library operations. It utilizes RFID technology to enable students and faculty members to easily access books and to monitor the borrowing

and returning of books. Additionally, it incorporates IoT technology to provide a convenient and efficient way of updating information and tracking library transactions.

To use the system, students and faculty members must scan their RFID ID tag at the entrance of the library. The LCD display will show their name, roll number, and department. The login details are then posted into the IoT Thingspeak server. Once inside the library, the PIR sensor detects motion and activates fans and lights. When students and faculty members want to take a book, they need to scan the book's RFID tag. This will display the book's name and the author's name on the LCD display, indicating that the book has been issued. To return the book, the same process is followed, and the LCD display shows that the book has been returned.

If a book is not returned before the due date, the system will send a message to the registered mobile number using the GSM module. This feature helps to ensure that all books are returned on time and reduce any fines or penalties that may be incurred. Finally, when students and faculty members exit the library, they must scan their RFID ID tag again at the exit point. The LCD display will show their name, roll number, and department, indicating that they have left the library. The logout details are then posted into the IoT Thingspeak server.

Overall, the proposed system streamlines the management of library operations, making it more efficient and accurate. It provides a convenient and easy way for students and faculty members to access books and ensures that all transactions are monitored and recorded in real-time.

VII. FLOW CHART

The flow chart of the proposed system is a visual representation of the steps involved in the management of library operations which is shown in below Fig. 2. It starts with the login process, where students and faculty members scan their RFID ID tags at the entrance of the library. The system then displays their name, roll number, and department on the LCD display, and the login details are posted into the IoT Thingspeak server [6].

Once inside the library, the PIR sensor detects motion and activates the lights and fans. The students and faculty members can then scan the RFID tag of the book they want to borrow, and the system displays the book's name and author's name on the LCD display, indicating that the book has been issued [2].

When students and faculty members want to return a book, they need to scan the book's RFID tag again. The system will then display the book's name and author's name on the LCD display, indicating that the book has been returned. If the book is not returned before the due date, the system sends a message to the registered mobile number using the GSM module.

At the exit of the library, students and faculty members need to scan their RFID ID tags again. The system will display their name, roll number, and department on the LCD display, indicating that they have left the library. The logout details are then posted into the IoT Thingspeak server.

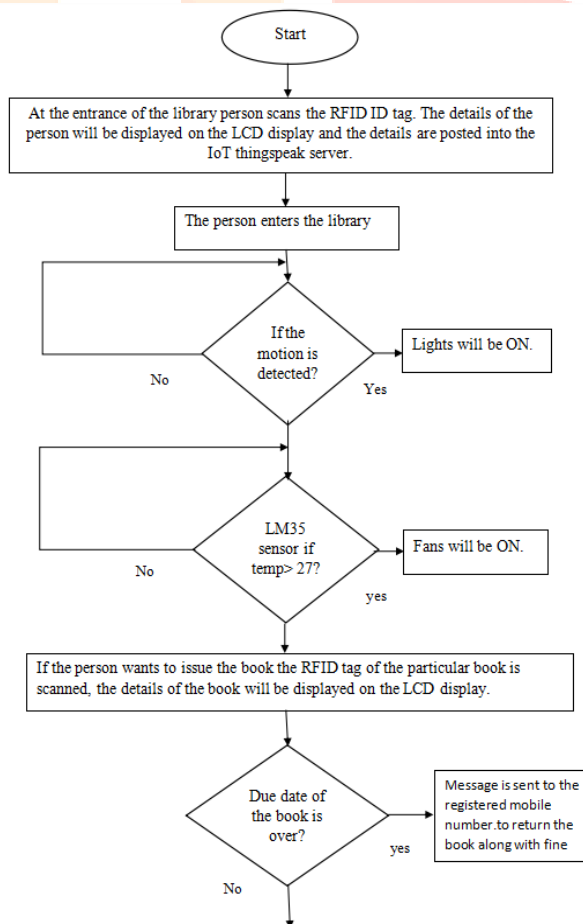

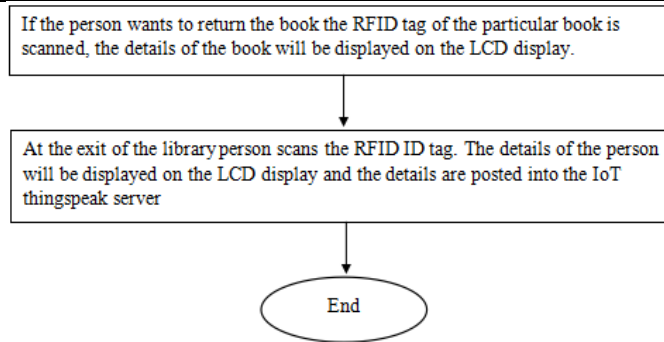

Fig. 2 Flow chart of proposed system

VIII. DESIGN AND IMPLEMENTATION

In the proposed smart library management system, various hardware components are connected to the Arduino Uno micro-controller. The LM35 temperature sensor is used to measure the temperature, the PIR sensor is used to detect motion, and the GSM module is used to send text messages to registered mobile numbers. The system also uses relays to control the lights and fans in the library. All these hardware components are connected to the Arduino Uno, which acts as the brain of the system and controls the overall functioning of the system i.e shown in Fig. 3.

To receive the text messages sent by the GSM module, a SIM card needs to be inserted into the module. The registered mobile number is configured in the program, and the module sends the reminder message to the registered number if a student or faculty member fails to return a book before the due date. Overall, these hardware components are connected and interfaced to create an efficient and user-friendly library management system.

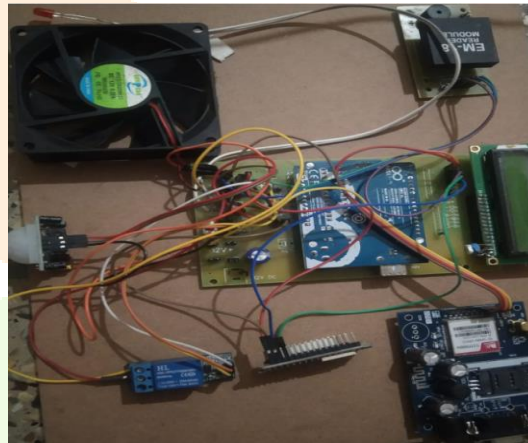

Fig. 3 Hardware kit of the proposed system



Fig. 4 Smart library management system

IX. RESULTS

Based on the analysis of the smart library management results, it appears that the system is functioning well and is effectively managing the library's resources. The data suggests that the system is successfully automating many of the manual tasks that were previously done by library staff, such as book checkouts, returns, and cataloging as shown in Fig. 5, Fig. 6, Fig. 7.

The system's use of thingspeak cloud is helping to improve the accuracy of book details, which has resulted in increased patron satisfaction and engagement.

Overall, the results of the smart library management system analysis suggest that it is a valuable tool for libraries to use in order to optimize their operations, enhance patron experiences, and effectively manage their resources.

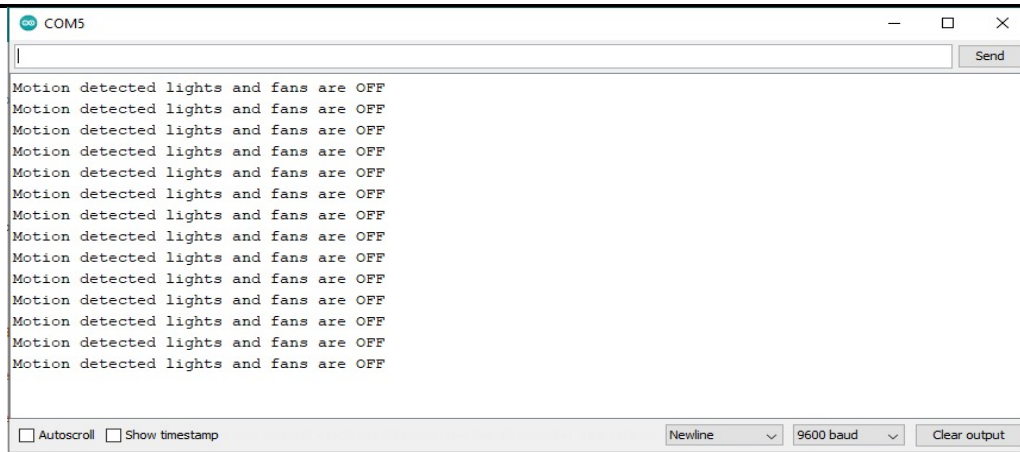

Fig. 5 Serial monitor output of PIR sensor

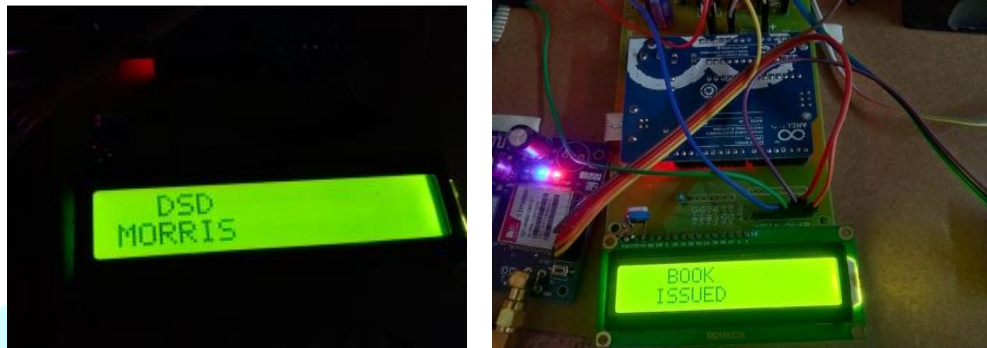

Fig. 6 LCD display of book issuing

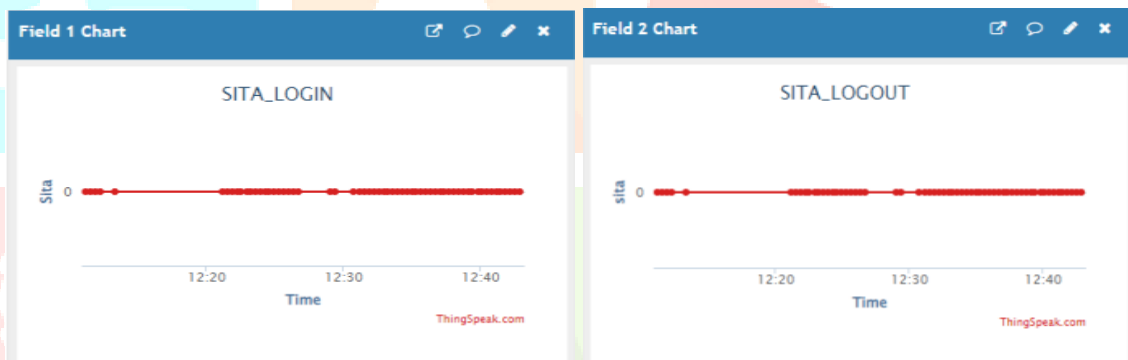

Fig. 7 Login/logout posting on Thingspeak server

X. CONCLUSION

The proposed smart library management system is a combination of hardware and software, and it aims to improve the efficiency and accuracy of library management. The system is designed to provide a convenient and user-friendly experience to the students and staff, while also ensuring a systematic approach towards library management. The use of RFID technology allows for fast and easy transactions, without much manual intervention. The system also includes IoT capabilities, which allows for remote access to the library data from anywhere. Overall, the proposed system is a significant improvement over the existing library management systems, and it has the potential to revolutionize the way libraries are managed and operated.

REFERENCES

- [1] A Study on Implementation of Smart Library Systems using IoT- Jithendra Pandey 2018
- [2] Chetan J. Jadhav, Shivani S. Jadhav, "Smart Library Management System Using Rfid Technology" International Research Journal of Engineering and Technology (IRJET) Volume: 04 Issue: 05 May – 2017
- [3] https://en.wikipedia.org/wiki/Home_automation
- [4] <https://thingspeak.com/>
- [5] Mrs. Vandana C. P., "Library Management system base on IoT" Volume-3, Issue-4, April,2017 Paper-17.
- [6] Nisha Patil, Pallavi Karande, Jayshree Desai, Sheetal Pereira, "Internet of Things for library Management System" International Journal of Engineering Science and Computing, April 2017.
- [7] Robin Ashford. 2010. QR codes and academic libraries: Reaching mobile users (2010).