



A Review Of Multi Path Routing And MPTCP Based Data Delivery Over Manets

Gulafshan Khan¹, Vivek Rai²

¹M.Tech, Dept. of CSE, B N College of Engineering & Technology, (AKTU), Lucknow, India

²Assistant Professors, Dept. of CSE, B N College of Engineering & Technology, (AKTU), Lucknow, India

Abstract: This review paper explain about the Mobile Ad-hoc Network (MANET) is a powerful organization between versatile hubs for sharing of data and is famous for its framework less plan. Because of the absence of focal administering body, in any case, different security dangers approach in MANETs in contrast with its framework based partners. Blackhole assault is one of the most difficult security issues present in MANETs. Blackhole assault lessens network effectiveness extensively by disturbing the progression of information among source and objective. In this paper, we approached a calculation which depends on the method of changing the grouping present number in charge parcels, specifically the Route Reply Packets (RREP) in broadly utilized Ad-Hoc On Demand Distance Vector (AODV) steering convention, to distinguish the blackhole hubs and subsequently to limit the information misfortune by disposing of the course with such Blackhole hubs. Reenactment results show that the proposed calculation outflanks the inheritance Intrusion Detection System (IDS) provisioned for AODV.

Keywords: MANET, Blackhole, RREP, AODV, IDS.

1. Introduction

An Ad-hoc Network is a brief association between hubs that is made spontaneously [1]. It depends upon no previous foundations like switches, passageways or base stations. Individual hubs associated with this sort of organizations can advance parcels to and from one another when they exist in one another's scope of transmission. At the point when versatile hubs lay out such organization it is alluded to as Mobile Ad-hoc Network (MANETs). In absence of a focal overseeing body to administer affirmation control, any hubs accessible inside the organization reach can without much of a stretch take part in MANETs.

Accordingly, security becomes powerless in MANETs. "Egotistical hubs can join the organization and disturb the got correspondence between different hubs and ultimately can present various security dangers [2]. One of such security issues is blackhole assault. Blackhole assault specifically influences the organization layer execution. A hub going about as blackhole drops the information bundles as opposed to transferring them to some other hub set apart as objective hub. In a blackhole assault, a hub promotes itself as the hub with most ideal course, for example a next jump hub having a new way with the least bounce build up to the objective hub. By the by, well known steering convention like AODV, then again, lean toward the course with least bounce count and greatest succession number" [3] [4] [5]. In such circumstances a blackhole hub can without much of a stretch fiddle with the security of the organization by communicating bogus data connecting with the jump count and arrangement and along these lines corrupt the organization execution[12].

AODV is an interest based table-driven steering convention. “The hubs present in AODV based network search for the courses to whatever other hub when there is a requirement for it, for example at the point when there is a need to send a few parcels to a specific hub (Destination Node) inside the organization[9][10]. AODV additionally has an arrangement of utilizing steering tables. Each hub keeps a directing table which keeps record of courses to various hubs in the organization in view of their cooperation in past bundle transmission record[11]. The records of courses kept up with in the table have a lifetime and courses are viewed as invalid in the event that they stay dormant till the generally set up expiry time” [5]. In unique organizations, for example, MANETs, numerous circumstances happen when a hub needs to communicate Route Request (RREQs) bundle to specific objective hub.

Endless supply of such parcels, if a next bounce blackhole hub ends up running over the RREQ bundle, “it quickly answers with a bogus Route Reply (RREP), introducing itself as the hub having least conceivable number of jumps (to the objective hub) and greatest conceivable grouping number; promoting itself as the most practical next jump hub[12]. Since the blackhole hub answers with the RREP bundle without searching for a practical course in the steering table or broadcast its very own RREQ, clearly the answer from the malignant hub might be the earliest answer to arrive at the source hub”[15]. Thus all things considered, the source hub utilizes the course comprising of the blackhole hub which at last keeps the information from arriving at the objective hub coming about into loss of information[13][14].

In this audit paper segment I contains the presentation, area II contains the writing survey subtleties, segment III contains the insights concerning MANET, segment IV portray the MANET directing conventions segment V depict the MANET network security segment VI make sense of about sorts of assaults in MANET segment VII give finish of this examination paper.

2. RELATED WORK

Praveen Joshi, 2010, [1] “The hubs are allowed to move about and put together themselves into an organization. These hubs change position often. A MANET is a kind of specially appointed network that can change areas and arrange itself on the fly. Since MANETS are portable, they utilize remote associations with interface with different organizations To oblige the changing geography exceptional directing calculations are required. There is no single convention that fits all networks impeccably. The conventions must be picked by network attributes, like thickness, size and the versatility of the hubs. There is as yet continuous examination on portable specially appointed networks and the exploration might prompt shockingly better conventions and will likely face new difficulties. Current objective of this paper is to figure out the security Issues and their Countermeasures that are taken on the Network Layer”. Network security broadens PC security, consequently everything in PC security are as yet legitimate, yet there are different interesting points too.

K.Selvavinayaki, 2010, [3] “The propose guard dog component recognize the dark opening hubs in a MANET. This strategy initially recognizes a dark opening assault in the organization and afterward gives another course to this hub. In this, the exhibition of unique AODV and changed AODV within the sight of numerous dark opening hubs is find out based on throughput and parcel conveyance proportion”. In a wormhole assault, interlopers burrow the information from one finish of the organization to the next, driving far off network hubs to believe they are neighbors' and causing them to convey through the wormhole connect”. “The majority of the Routing conventions don't resolve the issues of the steering assault. This paper portrays an answer system which will beat the dark opening assaults in MANETs. The proposed arrangement is that the hubs validate each other by giving security authentication in computerized structure to the wide range of various hubs in the organization. The proposed strategy is to be adjusted on DSR convention”. This technique is fit for identifying and eliminating dark opening hubs in the MANET”.

G.S. Mamatha, 2010, [4] The principal concerned security issue in portable impromptu organizations is to safeguard the organization layer from malevolent assaults, subsequently distinguishing and forestalling vindictive hubs. “A brought together security arrangement is in a lot of need for such organizations to safeguard both course and information sending activities in the organization layer. With next to no proper security arrangement, the vindictive hubs in the organization can promptly act to work as switches. This will exclusively upset the organization activity from right conveying of the bundles, similar to the vindictive hubs can give old directing updates or drop every one of the parcels going through them. In this paper a review that will through light on such assaults in MANETS is introduced”. The paper likewise centers around various

security parts of organization layer and examines the impact of the assaults exhaustively through a review of approaches utilized for security reason.

Nital Mistry, 2010, [5] The expansion of Mobile Adhoc Networks (MANETs) help to understand the migrant registering worldview with pervasive access. “However they guarantee self-viable, dynamic and brief geography, the MANETS likewise experience the ill effects of limitations in power, stockpiling and computational assets. Likewise, the inescapability, omnipresence and the innate remote nature, warrant proper security arrangements in these organizations that becomes hard to help, in the midst of the absence of adequate asset qualities. Thus, the MANETs are more helpless against different interchanges security related assaults. In this paper, hence, we endeavor to zero in on dissecting and working on the security of one of the famous steering convention for MANETS viz. the Ad hoc On Demand Distance Vector (AODV) steering convention. Our concentrate explicitly, is on guaranteeing the protection from the Blackhole Attacks. We propose adjustments to the AODV convention and legitimize the arrangement with proper execution and reenactment utilizing NS-2.33. Our investigation shows huge improvement in Packet Delivery Ratio (PDR) of AODV in presence of Blackhole assaults, with minimal ascent in normal start to finish delay”.

SUSHIL KUMAR CHAMOLI, 2012, [6] Wireless portable specially appointed network (MANET) is a self-arranging network which is made out of a few versatile hubs. “These portable hubs speak with one another with practically no foundation. As remote impromptu organizations miss the mark on foundation, they are presented to a great deal of assaults. One of these assaults is the Black Hole assault. In Black Hole assault, a malignant hub dishonestly promotes most brief way to the objective hub and assimilates all information parcels in it. Thusly, all bundles in the organization are dropped. In this paper, execution of AODV is assessed in presence of dark opening assault (malignant hub) and without dark opening assault with cbr traffic under various adaptable organization portability”. For this examination RWP model is utilized.

Table 1: Different technique used for object detection Securing Black hole Attacks in MANETs

S.N	Paper Title	Paper Authors	Technique
1	“Impact of Blackhole Attack in MANET”	Moitreyee Dasgupta , Gaurav Sandhu,	Cryptography, AODV
2	“Intercepting Blackhole Attacks in MANETs: An ASM-based Model”	Sebastiano Pizzutilo , Alessandro Bianchi,	N-AODV protocol
3	“A Modified AODV Routing Protocol to Avoid Black Hole Attack in MANETs”	Abdelmgeid A. Aly , Tarek M. Mahmoud,	AODV Routing Protocol, IASAODV Protocol
4	“Security issues in routing protocols in MANETs at network layer”	Praveen Joshi	Proactive routing protocols, Reactive routing protocols
5	“Performance Analysis of TSDRP and AODV Routing Protocol under Black Hole Attacks in MANETs by Varying Network Size”	Akshai Aggarwal , Nirbhay Chaubey	TSDRP routing protocols, AODV Routing Protocol
6	“Simulation of AODV under Blackhole Attack in MANET”	Mangesh Ghonge	AODV, blackhole attack
7	“Black-Hole and Wormhole Attack in Routing Protocol AODV in	Tushar P. Thosar , Amol A. Bhosle,	AODV Routing Protocol

	MANET”	
--	--------	--

3. About MANET

Portable systems administration is one of the more imaginative and testing areas of remote systems administration, one which vows to turn out to be progressively present in our lives. “Comprising of gadgets that are independently self-sorting out in networks, specially appointed networks offer an enormous level of opportunity at a lower cost than other systems administration arrangements. A MANET is an independent assortment of portable clients that convey over moderately "slow" remote connections. Since the hubs are versatile, the organization geography might change quickly and erratically over the long haul. An important remote organization ought to have the option to deal with the chance of having portable hubs, which will no doubt build the rate at which the organization geography changes. As needs be the organization must have the option to adjust rapidly to changes in the organization geography”. This suggests the utilization of effective handover conventions and auto setup of showing up hubs.

Table 2 Attacks against MANETS Network

Passive Attacks	eavesdropping, Snooping, traffic analysis, monitoring
Active Attacks	black hole, gray hole, Wormhole, information disclosure, resource consumption, routing attacks

4. MANET Routing Protocols

The hub finds out about new close to hubs and ways of contacting them, and reports that it can likewise arrive

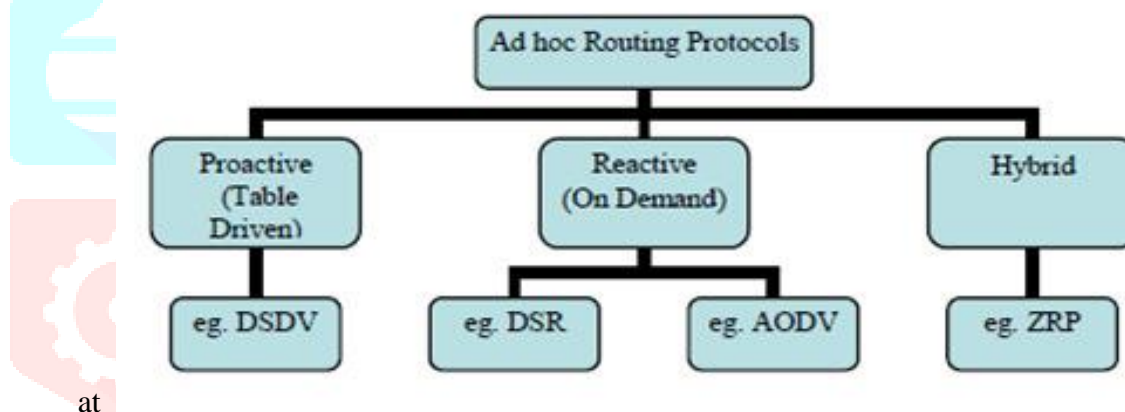

Figure 1: Routing Protocol Hierarchy

that routing hub. An Ad hoc steering convention is a show or standard that controls how hubs come to concur what direction to course parcels between processing gadgets in a MANET. In specially appointed networks, hubs don't have deduced information on geography of organization around them, they need to find it. The essential thought is that another hub reports its presence and pays attention to communicate declarations from its neighbors”. The hub finds out about new close to hubs and ways of contacting them, and reports that it can likewise arrive at those hubs. Steering conventions may commonly be arranged as:

- (a) Table-driven OR Proactive steering conventions.
- (b) On-request OR Reactive steering conventions.

5. MANET Network Security

Various factors diversely affect security issues and plan. In the event that the hubs are exceptionally a long way from every others, the gamble of safety assaults increments. Then again, assuming the hubs are so near one another's that they really can have an actual get in touch with, some privileged intel (for example secret keys) can be communicated between the hubs without sending them on air. That would build the degree of safety, in light of the fact that the actual correspondence lines are safer than remote correspondence lines. “The last factor of Ad Hoc networks portrayed as for security will be security criticality. This intends that before we consider the ways of carrying out security, we should consider cautiously regardless of whether security is

expected by any means or whether it makes a difference assuming somebody outside can see what bundles are sent and what they contain”.

Table 3 Attacks on Layers of the Protocol Stack

Layer	Attacks
Application layer	data corruption ,Repudiation,
Transport layer	SYN flooding, Session hijacking
Network layer	Resource consumption, Wormhole, blackhole, attacks location disclosure
Data link layer	Traffic analysis, monitoring, WEP weakness
Physical layer	Jamming, interceptions, eavesdropping
Multi-layer attacks	man in the middle, DoS, impersonation, replay

6. Types of Attacks in MANET

Because of their specific engineering, impromptu organizations are more handily assaulted than wired network. We can recognize two sorts of assault: the aloof assaults and the dynamic assaults. A uninvolved assault doesn't upset the activity of the convention, however attempts to find important data by paying attention to traffic. “All things being equal, a functioning assault infuses erratic parcels and attempts to disturb the activity of the convention to restrict accessibility, gain confirmation, or draw in bundles bound to different hubs”. The directing conventions in MANET are very unreliable on the grounds that assailants can without much of a stretch acquire data about network geography.

- “Assaults Using Modification: One of the least difficult ways for a malignant hub to upset the great activity of a specially appointed network is to declare better courses (to arrive at different hubs or simply a particular one) than different hubs. This sort of assault depends on the alteration of the measurement an incentive for a course or by adjusting control message fields”.
- “Assaults utilizing pantomime: These assaults are called caricaturing since the malignant hub conceals its genuine IP address or MAC locations and utilizations another. As current specially appointed directing conventions like AODV and DSR don't verify source IP address, a malignant hub can send off many assaults by utilizing parodying. For instance, a programmer can make circles in the organization to disengage a hub from the rest of the organization. To do this, the programmer simply needs to take IP address of other hub in the organization and afterward use them to declare new course (with littlest measurement) to the others hubs. By doing this, he can without much of a stretch adjust the organization geography as he needs”.

7. CONCLUSION

This review research paper introduced the investigation for a safety concern named MANETs blackhole and examined that effect on organization. Likewise, the current answers for the concern are considered, broke down and in light of that another calculation is approved. The approved calculation is exceptionally straightforward that can run successfully in contrast with the heritage calculations. The legitimacy of the approaches calculation is additionally checked through network recreation.

References

- [1] Praveen Joshi, "Security issues in routing protocols in MANETs at network layer", *Procedia Computer Science* 3 (2011) 954–960
- [2] Nirbhay Chaubey, "Performance Analysis of TSDRP and AODV Routing Protocol under Black Hole Attacks in MANETs by Varying Network Size", Conference Paper · February 2015, DOI: 10.1109/ACCT.2015.62
- [3] K.Selvavinayaki, "Security Enhanced DSR Protocol to Prevent Black Hole Attacks in MANETs" , *International Journal of Computer Applications (0975 – 8887) Volume 7– No.11, October 2010*
- [4] G.S. Mamatha, "Network Layer Attacks and Defense Mechanisms in MANETS- A Survey", *International Journal of Computer Applications (0975 – 8887) Volume 9– No.9, November 2010*
- [5] Nital Mistry, "Improving AODV Protocol against Blackhole Attacks", IMECS, 2010
- [6] SUSHIL KUMAR CHAMOLI, " Performance of AODV against Black Hole Attacks in Mobile ad-hoc Networks", Sushil kumar Chamoli et al ,*Int.J.Computer Technology & Applications*, Vol 3 (4), 1395-1399
- [7] Amol A. Bhosle, "Black-Hole and Wormhole Attack in Routing Protocol AODV in MANET", *International Journal of Computer Science, Engineering and Applications (IJCSEA) Vol.2, No.1, February 2012.*
- [8] Payal N. Raj, "DPRAODV: A DYANAMIC LEARNING SYSTEM AGAINST BLACKHOLE ATTACK IN AODV BASED MANET", *IJCSI International Journal of Computer Science Issues*, Vol. 2, 2009
- [9] S. G. Klauer, F. Guo, B. G. Simons-Morton, M. C. Ouimet, S. E. Lee, and T. A. Dingus, "Distracted driving and risk of road crashes among novice and experienced drivers," *New England Journal of Medicine*, vol. 370, no. 1, pp. 54–59, 2014.
- [10] T. A. Ranney, E. Mazzae, R. Garrott, and M. J. Goodman, "NHTSA driver distraction research: Past, present, and future," in *Driver Distraction\ Internet Forum*, 2000.
- [11] O. Olarte, "Human error accounts for 90% of road accidents," <http://www.alertdriving.com/home/fleet-alertmagazine/international/human-error-accounts-90-road-accidents>.
- [12] J. Tison, N. Chaudhary, and L. Cosgrove, "National phone survey on distracted driving attitudes and behaviors," National Highway Traffic Safety Administration, Tech. Rep., 2011.
- [13] M. Vegega, B. Jones, and C. Monk, "Understanding the effects of distracted driving and developing strategies to reduce resulting deaths and injuries: a report to congress," National Highway Traffic Safety Administration, Tech. Rep., 2013.
- [14] Y. Artan, O. Bulan, R. Loce, and P. Paul, "Driver cell phone usage detection from HOV/HOT nir images," in *IEEE Conference on Computer Vision and Pattern Recognition Workshops*, 2014, pp. 225–230.
- [15] K. Seshadri, F. Juefei-Xu, D. Pal, M. Savvides, and C. Thor, "Driver cell phone usage detection on strategic highway research program (shrp2) face view videos," in *IEEE Conference on Computer Vision and Pattern Recognition Workshops*, 2015, pp. 35–43.