



LITERATURE REVIEW ON BRUSHLESS DC MOTOR MODELLING, ANALYSIS AND CONTROL METHODS

¹Nandhini Balavelayutham, ²Alamelumangai Meyyappan,

¹Assistant Professor, ²Assistant Professor,

¹ Department of Electrical and Electronics Engineering,

¹ Nehru Institute of Engineering and Technology, Coimbatore, India

Abstract: Unique Brushless Direct Current (BLDC) motors are progressively being utilized in modern applications and electric vehicles. To plan and control the machine for high unique execution, just as for constant shortcoming determination of the BLDC drives, scientific demonstrating is regularly the principal step. This paper presents a study of various methods of displaying and examination of BLDC motors alongside their control methods. Along with the customary BLDC control, diverse current control calculations like state input control component and novel procedure of IC based control calculation are broadly being utilized for controlling the motor, which are accounted for in the paper as well. BLDC motor is demonstrated and recreated and the reenactments results are remembered for the paper. In conclusion, significant uses of BLDC motors are recorded

Index Terms - Brushless Direct Current (BLDC), Electric Power Steering (EPS), Special Electrical Motors.

I. INTRODUCTION

The Overall, brushed dc and customary ac electric motors (like acknowledgment and facilitated motors) are being used by and large. Regardless, continuous movements in durable magnet advancement, power devices and controllers have made remarkable electrical motors, as Switched Reluctance Motors (SRM), Permanent Magnet Synchronous Motors (PMSM) and Permanent Magnet Brushless DC Motors (PM BLDC) fundamentally more fitting for capable drive action. These motors are depicted by a higher adequacy, more unmistakable trustworthiness, and more power thickness requiring less upkeep [1]. Dependent upon the necessities, these motors track down applications in various electrical systems. Without a doubt the best components of this motor which make it sensible for world class execution applications are - higher power to motor size extent, high usefulness and long life. In view of these characteristics, BLDC motors are comprehensively used for present day applications and the assessment in this space has experienced a quick improvement of late. Many examination distributions have announced novel strategies for BLDC motor plan and investigation. New control calculations are being created for productive motor. A few ongoing distributions accentuate on the improvement of the proficiency, decrease of force waves and shortcoming determination of BLDC motors.

This paper makes an endeavour to gather applicable data as for the demonstrating and examination of BLDC motors. Different boundary assessment procedures are examined exhaustively too. Alongside the regular control strategies, imaginative control calculations, for example, state feedback control system and novel strategy of IC based control calculation are talked about too. In conclusion the utilization of BLDC motors alongside the advantages of supplanting regular motors with these motors has been depicted.

II. MODELING AND ANALYSIS OF BLDC

The BLDC motor is a dc motor with the shortfall of brushes on the rotor. Substitution of this motor is performed electronically at specific rotor positions as should be visible from Fig .1 Hall Effect Sensors are utilized to detect the changing place of the PM rotor

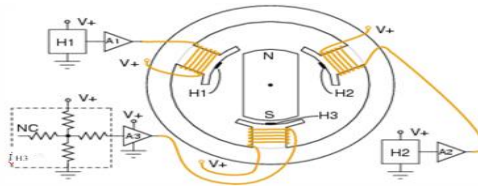

Fig1.Three Phase Brushless DC motor showing hall effect sensors

The most common way of detecting includes the adjustment of extremity of the passing rotor magnet. The Hall signals are then additionally enhanced to drive the stator loops with the legitimate current. The Hall signals are now and then handled by combinatorial rationale for more proficient drive waveforms.

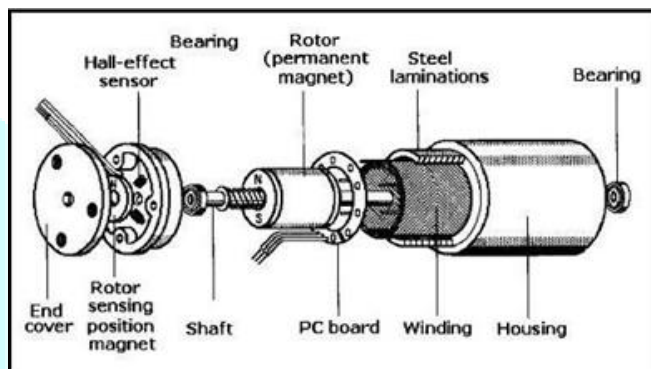

Fig2. Dismantled view of a brushless dc motor

Fig 2.shows the dismantled perspective on a BLDC motor showing the single PM rotor, winding game plan and Hall impact sensors to detect the rotor position of an motor. The windings of the motor can be arranged in various styles. They can either be embedded in the spaces or can be twisted as a loop on the attractive post. The back-emf has a trapezoidal shape which can be acquired by appropriate position of the extremely durable magnets and right rotor uprooting. The three-stage voltage supply with a rectangular shape accordingly delivers a rotational attractive field bringing about low force swells. BLDC motor in this way can be considered as comparable to a modified DC commutator motor wherein the magnets turn while the guides stay fixed. Fig.3 shows essential control block schematic of a BLDC motor. Demonstrating of a BLDC motor is like that of a simultaneous machine. The motor is taken care of by a three stage voltage source inverter coupled to a full extension rectifier. The BLDC motor yield (rotor position) is taken care of back to the regulator, the result of which is taken care of to the inverter of the framework as displayed in Fig.3. Square or sinusoidal wave shape can be applied as the info voltage to such an extent that the pinnacle voltage doesn't surpass the greatest furthest reaches of the motor. The model of the armature windings for the BLDC motor is communicated as conditions which are talked about ahead.

$$V_a = R_a i_a + L (di_a/dt) + e_a \quad (1)$$

$$V_b = R_b i_b + L (di_b/dt) + e_b \quad (2)$$

$$V_c = R_c i_c + L (di_c/dt) + e_c \quad (3)$$

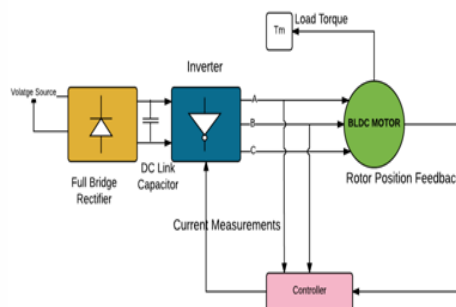

Fig3. Electric circuit model for BLDC motor

Where V_a, V_b, V_c and I_a, I_b, I_c are phase voltage and phase current and e_a, e_b, e_c are back emf voltages of the BLDC motor.

$$e_a = K_e \omega_m F(\theta_e) \quad (4)$$

$$e_b = K_e \omega_m F(\theta_e - 2\pi/3) \quad (5)$$

$$e_c = K_e \omega_m F(\theta_e + 2\pi/3) \quad (6)$$

where,

ω_m is Angular speed of rotor.

θ_m is Rotor Mechanical angle.

θ_e is Rotor Electrical angle

The underlying advance for the arrangement and control of any motor is its exhibiting and assessment. W. Hong et.al in their paper propose a motor model replicated using MATLAB close by amusement results tended to in graphical UI (GUI). In their work, they propose a model of brushless DC motor contemplating behavior of the motor during reward. The power typical for BLDC motor presents a crucial part in arrangement of the BLDC motor drive structure, in this way making it critical to predict the specific worth of power, still hanging out there with the help of waveforms of back-EMF. The back emf of a BLDC motor is then affirmed by amusements done on MATLAB SIMULINK mechanical assembly. Table I gives the limit potential gains of the BLDC motor while Fig. 4. shows the back emf.

Table1. Parameter Specifications for modeling of BLDC Motor

Parameter	Value
Speed (N in RPM)	1000
Voltage (Vin volts)	160
Poles of the Motor (P)	4
Motor phases (1jJ)	3
Stator Phase Resistance (R, in ohm)	0.7
Torque Constant (k)	0.84
Load Torque	2 N-m
Back emf area (degree)	120
Rotor Initial Position (9 in	0

degrees)	
Kp and Ki;=Proportional and Integral Constant	0.002 and 5

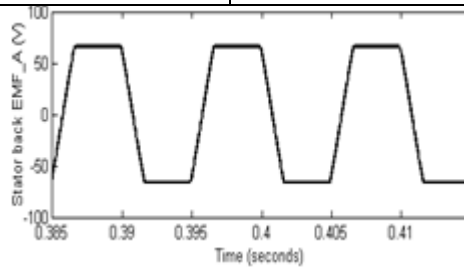

Fig.4. Trapezoidal shape of back-emf for a BLDC

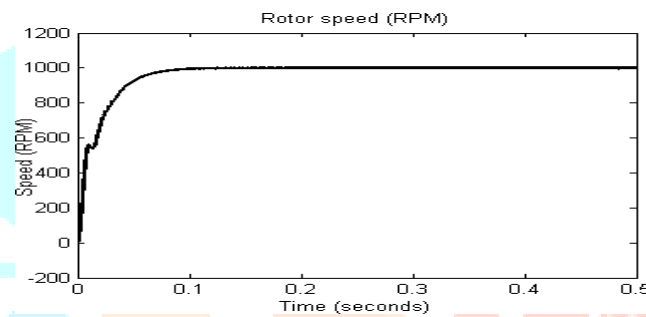

Fig.5. Rotor speed for a modeled BLDC Motor

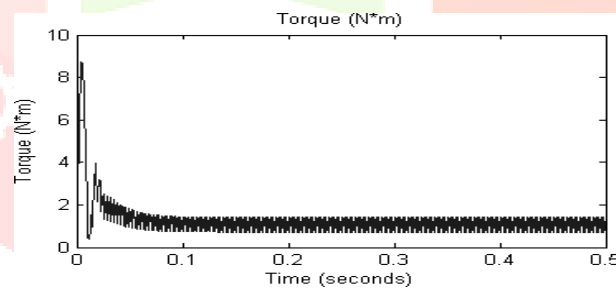
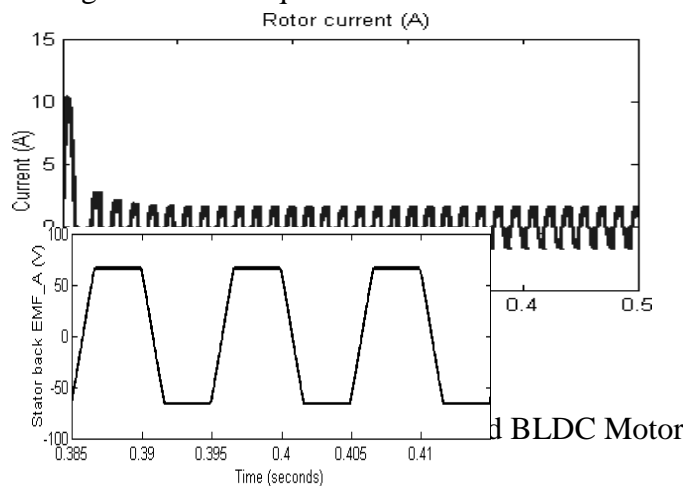

Fig.6. Motor Torque for a modeled BLDC Motor



BLDC Motor

The SIMULINK model organized can similarly check various limits like speed, current and power; required for the showing and limit appraisal of a BLDC Motor. Fig. 5, Fig. 6 and Fig. 7 shows the speed, current and power of a BLDC Motor.

Fig.8. BLDC motor with a three phase inverter circuit

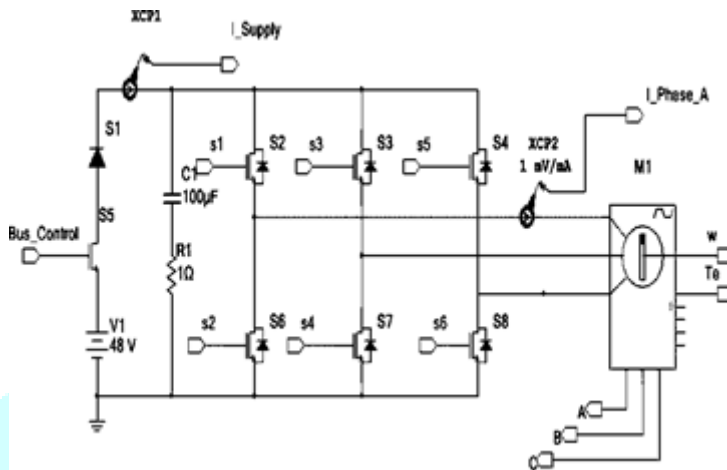

Fig.8. BLDC motor with a three phase inverter circuit

While Considering, R in his paper undergone on the new strategy of co-simulation investigation of BLDC Drive. Co-simulation strategy includes the coordination of at least two calculations performed on various recreation stages. Here, two stages in particular LabVIEW and Multisim perform co-re-enactment studies on the BLDC model. The total BLDC motor driver framework comprises of a (i) BLDC motor (ii) three stage inverter circuit and (iii) an advanced regulator unit. In the paper, these three systems are created on different simulation stages - the three stage inverter circuit and the driver circuits on Multisim the replacement algorithm on LabVIEW. They are coordinated by the co-- reproduction element of Lab view and Multisim programs [12].

First, the mathematical model of the BLDC motor is made and duplicated using MATLAB and Lab view programming instruments. Co-generation strategy was used as a second step where the mix of made models is done

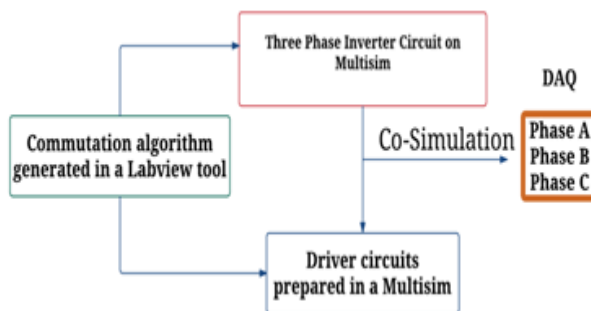
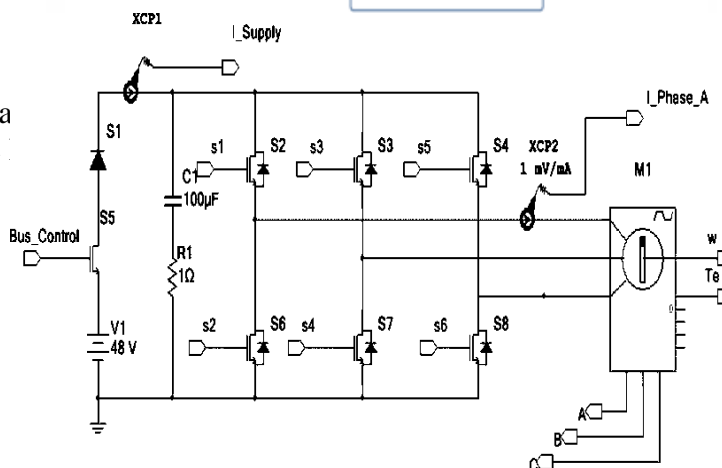

Fig.8. shows the three sta calculation is done on the Fig.9.



while the computational mimicked as displayed in

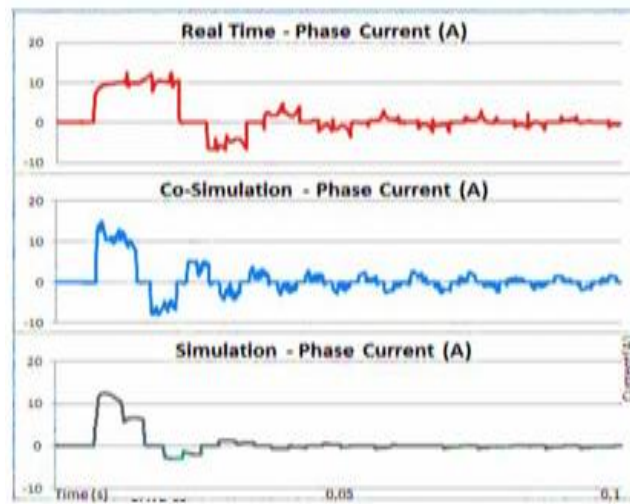

Fig 10. Current in Real Time, Simulation and Co-Simulation for Phase A (24V)

Fig.10. shows the stage and transport current information of BLDC motor [12]. The stage current got through Real Time Simulation Technique and by Co-Simulation Technique is accordingly looked at and dissected. The near concentrate on done shows the benefit of involving co-reenactment procedure for the better result.

P. Pillay et.al have depicted in their paper the high level model of BLDC motor drives. The creators think about the replacement conduct and back-EMF wavefonn for dynamic reproduction of a BLDC motor drive framework [11]. The attainability and execution of the model is inspected by reproduction of the drive. The constraints of this technique i.e reenactment speed and necessity of connecting with multiple devices are referenced by the creators.

P. Muresan, A. Forrai, and K. Biro [10] present another displaying method for Brushless DC (BLDC) motor drives utilizing buck converter, as should be visible in Fig.II. This model addresses a consistent speed activity of a BLDC motor drive worked without a DC connect capacitor [10]. A solitary switch PWM activity while keeping the other switch in ON state for the whole exchanging span is proposed in this paper.

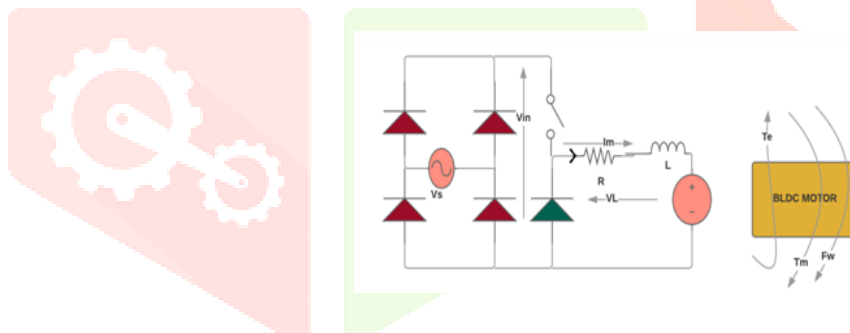

Fig11. A buck converter based model of the drive

the benefit of involving co-reenactment procedure for the better result.

This doesn't need a DC connect to drive the motor. At the point when the controlled switch is in OFF express, the way for the motor stage current is given by the other switch which is ON. With this proposed method, intricacy can be diminished. This geography enjoys a benefit of further developed execution and minimal expense [10].

III. CONTROL METHODS FOR BLDC MOTOR

This segment presents an audit of new arising control strategies for BLDC motors. These strategies are novel and are unique in relation to the customary control techniques utilized before. The most normally utilized PID regulators are the regulators actually utilized broadly in modern area. This is because of the way that these regulators are basic and strong. In any case, the principle disadvantage of not getting adjusted to time changing attributes make them second rate when contrasted with the arising control calculations which are examined ahead in this paper. PID regulator tuning is likewise difficult and feasible [14]. Thus the conversation on original procedures is explained in this part.

Road accidents are undoubtedly the most frequent and, overall, the cause of the most damage. So, it is necessary to take correction measures within the prescribed time to save lives. In case of crowd areas, people will be able to help the victims. But in deserted areas, it is necessary to detect the victim once he/she is harmed.

In previous detection methods, we need internet to connect the server and the client. An embedded system has been developed which observes an object, the system also sends a alert message to the authorized user through Wi-Fi direct technology such that remedy measures can be easily taken irrespective of internet connection. These features are embedded into an robot and is allowed to monitor the restricted/ deserted places [1]

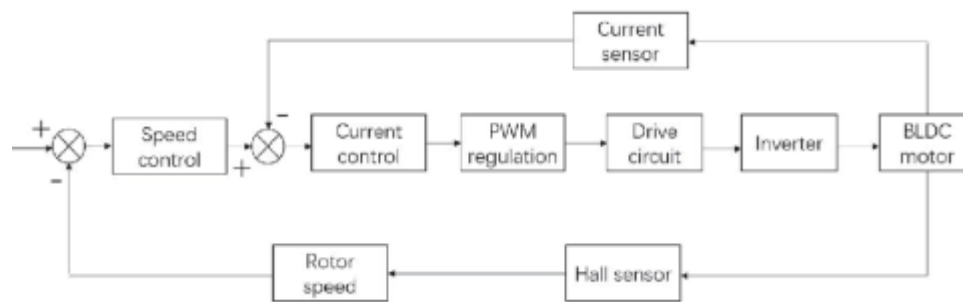

Fig.12. Block diagram showing digital PWM control operation for a BLDC motor drive system

Fig.12 shows the total square chart of the motor drive framework with the proposed regulator. This straightforward control strategy can possibly be executed as a minimal expense application explicit circuit. The demonstrating and reenactment investigation has been performed on the regulator and the outcomes are confirmed. The exploratory set-up is assembled involving FPGA for approval [16].

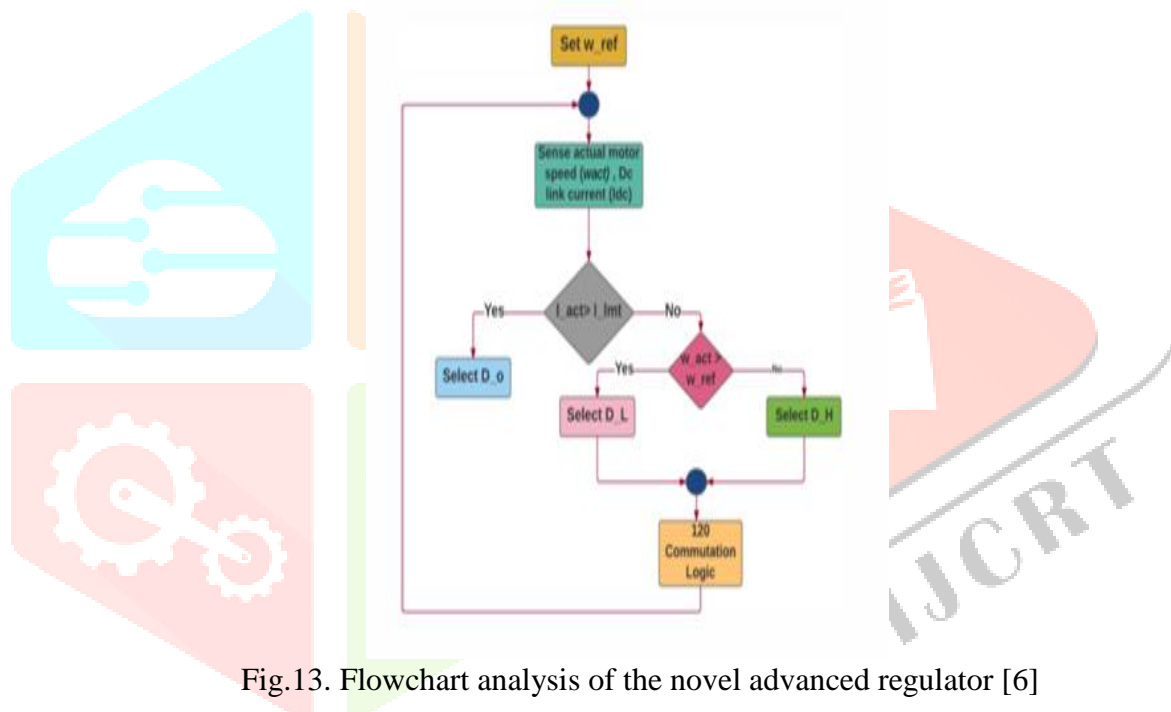

Fig.13. Flowchart analysis of the novel advanced regulator [6]

Fig.13 shows the proposed advanced regulator as a flowchart. The uniqueness of this regulator is that it doesn't need any current or state spectators.

A current breaking point is given by a relative regulator which gives a reference to restrict the current among greatest and least qualities as characterized. The most extreme worth characterized for current is 1.5 occasions the evaluated current of the motor. This is done in light of the fact that for a brief length, the motor can deal with 1.5 occasions the evaluated current. Then again the base worth chooses the consistent state mistake. The proportion of a rate (1%) of the appraised force to the force consistent can be characterized as the base worth of current [16].

3.1 Trapezoidal Control

Trapezoidal control is the simplest method and involves commutating the motor phases in a trapezoidal pattern.

It is suitable for applications with lower performance requirements, where precise control is not necessary. Trapezoidal control is often used in cost-effective and low-complexity systems.

3.2 Sinusoidal Control

Sinusoidal control uses a sinusoidal commutation pattern to control the motor. It provides smoother motion and reduced torque ripple compared to trapezoidal control. Sinusoidal control is more efficient and suitable for applications requiring higher precision and lower noise.

3.3 Field oriented Control

FOC, also known as vector control, is a more advanced method that decouples the control of torque and flux. It offers excellent control over speed, torque, and efficiency. FOC is commonly used in high-performance applications such as electric vehicles and industrial machinery.

3.4 Direct Torque Control

DTC provides precise control over torque and speed by directly controlling flux and torque. It offers low torque ripple and noise, high efficiency, and fast dynamic response. DTC is suitable for demanding applications like robotics and high-performance industrial systems.

3.5 Sensorless Control

Sensorless control methods eliminate the need for position sensors such as Hall-effect sensors or encoders. These methods estimate rotor position and speed using back EMF, phase currents, or other motor parameters. Sensorless control is cost-effective and suitable for applications where sensor reliability is a concern.

3.6 Sensored Control

Sensored control relies on position sensors (e.g., Hall-effect sensors or encoders) to determine the rotor's position. This method provides accurate and precise control of the motor, especially at low speeds. Sensored control is commonly used in applications where accuracy and reliability are critical.

3.7 Pulse width Modulation Control

Pulse-width modulation (PWM) control is a basic technique used to control the power supplied to the motor. It is suitable for simple speed and direction control in various applications. PWM control is often combined with other control methods for more advanced motor control.

3.8 Closed Loop Control

Closed-loop control systems use feedback from sensors (position, speed, or current) to adjust control parameters in real-time. This provides better accuracy, stability, and reliability in various applications, especially those with changing loads.

IV APPLICATIONS OF BLDC MOTORS

This segment portrays the plan and examination of BLDC motors for application explicit destinations. Because of the way that BLDC motors have higher force conveyed to motor size proportion, high effectiveness and long life, this motor finds its application in rocket, water siphons, electric vehicles and wind energy applications. A ton of exploration is at present being centered on progress in execution and productivity of such drives for explicit applications.

with this sort of plan. End of cogging force and attractive striction;- accomplished by utilizing this kind of coreless arrangement. The machine fosters a pinnacle force of 1.08 N-m at 1 an excitation current and is found to suit the plan prerequisites for rocket applications [14]

2. Electric Vehicle (EV)[12-9], Electric Drive trains [10]. and Electric Power Steering (EPS) [3]: In a new paper Chan, T., Yan, L. T. and Fang, S. Y concentrate on electromagnetic and parametric plan of an in-wheel

out-sprinter BLDC motor which is planned explicitly for car applications. The reproduction legitimizes that the BLDC motors have high force to motor size proportion and great controllability to drive EVs. The exhibition boundaries are assessed which remember yields for terms of stage inductance, transition linkages of every stator winding and static forces for various rotor positions [4]. The paper studies the dynamical performance analysis and co-recreation procedures for the BLDC Motor which are now been examined before in papers [12-10]. Though as Electric Power Steering (EPS) which is a piece of EVs, creators, for example, G. Prasad et.al [3] portrays in their paper about the organization of electric power directing (EPS) framework and the upsides of utilizing BLDC motor in the framework. The creators demonstrate the practicality and unwavering quality of the framework through the recreation and trial work completed in their paper. The work introduced fills in as a plan strategy for a further exploration of BLDC motor in EPS [3].

3. Water Pump Application [3]: A financially savvy BLDC drive for water siphon application is planned by J. Shao in his article. By a similar investigation of two distinct plans, he proposes a clever plan answer for a BLDC where the throbbing force is limited. The regulator by the creator is an adjusted type of the regular field situated control. The regulator PCB is planned with only two layers to offer practical answer for this clever procedure. The creator gives the itemized depiction of the motor reproduction model and plan methodology for the regulator consequently approving the outcomes through a created model. The model of a private siphon with rating of 150-W was worked to feature the benefits in help to his work.

4. Lift [15]: A new distribution by Das Dwijasish et.al articulates the extent of utilizing BLDC motors for lift frameworks reasonable for working with dc microgrid. For breaking down the proposed BLDC motor based lift framework, a MATLAB Mechatronic reproduction model has been created by embedding different electrical and mechanical parts. Four quadrant activity of the proposed lift framework has likewise been demonstrated with the reproduction results [15]. Regenerative slowing down is additionally feasible for the proposed framework by utilizing a reasonable stuff system instead of worm gear. The creator has carried out a generally speaking shut circle regulator utilizing a FPGA

IV. RESULTS AND DISCUSSION

This paper has detailed displaying, examination and control techniques for BLDC motors. It underlines on various displaying and boundary assessment strategies for BLDC motors dependent on the approach which have diminished computational intricacy rather than the regular models. The primary target of each demonstrating is to assess the boundaries which are additionally utilized for either control component or issue analysis. A viable review on different control calculations like PWM, PI, and arising novel method of IC based control instrument are utilized for the control of BLDC motor drive framework; which further upgrades the survey to sum things up. As an examination fundamental work, an endeavour has been made on the friend investigation for displaying and control of BLDC motor which would be a guide to the future extension for this exploration work in the plan of a Fault Tolerant System (FTS) of a BLDC Motor. Further the most recent and arising patterns in utilizations of BLDC motors have been examined and depicted exhaustively as a piece of writing. Ultimately, explicit applications of BLDC motors are talked about

IV. ACKNOWLEDGMENT

The authors would like to thank the Head of the Electrical & Electronics Engineering Department, Head of Electronics and Communication Engineering Department and Research Team.

REFERENCES

- [1] Catherine Rakkini.D, Prof. Nandhini. B “ Design and Development of an Accident Detection Technique Based On the Incorporation of the Wifi Direct Technology”,International Journal of Engineering Trends and Technology (IJETT) – Volume-45 Number4 -March 2017 (2017)
- [2] Jenkins, James Scott. "Operation of a brushless DC drive for application in hybrid electric vehicles." (2007).
- [3] G. Prasad, N Sree Ramya, P.V.N. Prasad, G. Tulasi Ram Das, “Modelling and Simulation Analysis of the Brushless DC Motor by using MATLAB”, International Journal of Innovative Technology and Exploring Engineering (IJITEE), ISSN: 22783075, Volume -1, Issue-5, October 2012.
- [3] J.Shao,” An Improved Micro-controller Sensorless based BLDC Motor Drive for Automotive Applications,” IEEE Trans. on Ind. Applic., vol. 42, issue 5, pp. 1216-1221, 2006.
- [4] Chan, T., Yan, L. T. and Fang, S. Y., “In-wheel permanent-magnet brushless DC motor drive for an electric bicycle,” IEEE Transactions on Energy Conversion, vol. 17, no. 2, pp. 229 – 233 (2002).
- [5] W. Hong, W. Lee and B. K. Lee, “Dynamic Simulation of Brushless DC motor Drives Considering Phase Commutation for Automotive Applications”, IEEE International Electric Machines & Drives Conference, 2007. IEMDC 2007, pp.1377-1383, 3-5 May 2007.
- [6] B.Nandhini, R.Janani, “ A smart home monitoring system for elderly people”, International Journal of Emerging Technologies in Computational and Applied Sciences, 7(4), December 2013-February 2014, pp. 444-447.
- [7] K. J. Astrom, T. Hagglund, C. C. Hang, and W. K. Ho,“Automatic tuning and adaptation for PID controllers A survey,” IFAC J. Contr. Eng. Practice, 1993,vol.1,No.4,pp.699-714.
- [8] Dr.R.Deepa, S.M.Deepa, B.Nandhini “Performance Analysis of Channel Equalizers in Optical Communication for Next Generation Systems,” International Journal of New Innovations in Engineering and Technology, Volume 9 Issue 1 – October 2018 1 ISSN: 2319-6319
- [9] Lessons in Electric Circuit Vo.II-AC, 2000-2015, by Tony R. Kuphaldt.
- [10] P. Muresan, A. Forrai, and K. Biro, “Mathematical modelling and control of brushless dc drives - unified approach,” in Optimization of Electrical and Electronic Equipments, 1998. OPTIM '98. Proceedings of the 6th International Conference on, vol. 2, May. 1998, pp. 557 –562
- [11] P. Pillay and R. Krishnan, "Modeling, simulation, and analysis of permanent-magnet motor drives, part II: the brushless DC motor drive," IEEE Trans. on Industry Applications, vol. 25, no. 2, pp. 274- 279, March/April 1989.
- [12] Tekin, R., “MATLAB and LabVIEW in modeling, analysis and real time control of a motion control system Control and Automation (ICCA), 2010 8th IEEE International Conference on.,p. 2077-2081, 9-11 June 2010.
- [13] Stepheena Joseph, Mrs. B. Nandhini, “Implementation of WS For The Water Quality Assessment In A Real Time Application," International Research Journal of Engineering and Technology (IRJET) Volume: 05 Issue: 04 | Apr-2018
- [14] Q.F. Zhang, B.Q. Kou and S.K. Cheng: Micro & Special Motor, (2004) No. 6, pp. 33-37
- [14] R. P. Praveen, M. H. Ravichandran, V. T. SadasivanAchari, V.P. Jagathy Raj, G. Madhu and G. R. Bindu, "Design and analysis of zero cogging Brushless DC motor for spacecraft applications," Electrical Engineering/Electronics Computer Telecommunications and information Technology (ECTI- CON), 2010 International Conference on, Chaing Mai, 2010, pp. 254-258.
- [15] D. Das;"Development of BLDC Motor Based Elevator System Suitable for DC Microgrid," in IEEEIASME Transactions on Mechatronics , vol.PP, no.99, pp.I-1 (2015)
- [16] Masmoudi M, El Badsı B, Masmoudi A. Direct torque control of brushless DC motor drives with improved reliability[C]//Ecological Vehicles and Renewable Energies (EVER), 2013 8th International Conference and Exhibition on. IEEE, 2013: 1-8.