



LOCATING AND RETRIEVING LOST OBJECTS USING GEOLOCATION AND REAL TIME COMMUNICATION

¹Tessy Abraham,² Adarsh P,³ Arya A, ⁴ Athul Babu, ⁵ Diya S

¹ Assistant Professor,² UG Scholar,³UG Scholar, ⁴ UG Scholar, ⁵ UG Scholar

¹ Department of Computer Science and Engineering

¹ Mahaguru Institute of Technology, Kerala,India

Abstract: The discovery and return of lost things to their rightful owners are made easier by this document. This acts as a central location where users may report lost property, look for found property, and communicate with one another to reconnect property with owners. People may generate thorough reports on their missing things using the user-friendly interface, which includes descriptions, images, and other data. Other users who may have located or come across related goods are then given access to these reports. By reporting goods they find in their area that have been located, users may also actively engage in the network. They boost their chances of connecting with people who have reported the same item as lost by sharing information, pictures, and descriptions of the discovered objects.

Index Terms –Artificial Intelligence, Air Canvas, Digital Art, Gesture Recognition, Hand Tracking

I. INTRODUCTION

This Network is a user-driven tool created to assist individuals in finding lost objects and connecting them with their owners. It acts as a central digital location where people may report lost stuff, look for items that have been discovered, and interact with others who might know where their lost items are. The network makes use of technology and crowd sourcing to boost odds of finding lost objects and lessen the psychological and financial strain that comes with losing anything of value. The network often runs through a website or mobile application, offering users an intuitive interface for posting information about their missing belongings. Users can add details such as the item's description, the place where it went missing, and any distinctive characteristics that could be helpful.

What it can do is:

- 1.Used for discovery of objects.
- 2.Facilitate communication.
- 3.Reduce emotional and financial burden.
- 4.Better object recognition.
- 5.Collaboration with local authorities.
- 6.Foster a sense of trust and community

The majority of widely used programming languages are supported. Javascript is extensively used. The network's overall goal is to reunite lost objects with their rightful owners by using the strength of social interaction and technical breakthroughs to build a linked and encouraging environment. In order to improve the possibilities of retrieving lost property and to build a sense of trust and community, it offers a single platform where people can report, search for, and interact with one another[14].

II. PROBLEM STATEMENT

The efficient and effective handling of lost objects and their recovery to their rightful owners are frequently the focal points of this network's issue statement.[2] The main goal is to provide a single platform or system that makes it easier to report, monitor, and recover lost objects, hence reducing the time, effort, and annoyance encountered by those who have lost their belongings[15].

III. MOTIVATION

Our realities and lifestyles have become a much larger part of who we are now. The ultimate result of this article is what we come up with in order to access the most user-friendly way of discovering and obtaining an item. Through a centralised platform for this network, we fought to implement the most economical and available features[8].

IV. LITERATURE REVIEW

Technology, which has become a part of daily life, has given rise to a vast array of applications that can make life easier (gandal, 2001). Many systems that employ search engine techniques and information retrieval processes have been created recently to make it easier for users to do a variety of tasks[5]. V FOUND is a tool using web development as a technique; utilizing text matching and picture matching algorithms, the system will detect similarities and alert both parties, to name a few systems. Another tool that uses web building is SIMPLY FOUNDASTIC, however it's not a free site[7]. When an object is lost, the person who lost it must pay. People may simply use the community-based smart phone application TRAISTA. Find their missing pet and other amusement. NamUS is a platform for centralized repositories that uses unique online and mobile operations. It serves as a missing people resource center. Since it is solely available to US people, no one else in the world can use it[3].

V. EXISTING SYSTEM

vFound, Simply Foundastic, and other lost and found services are among the numerous ones. These systems largely operate in the same manner. Each party (those who lost and those who found) may provide a detailed report of their lost and discovered items. In order to utilise the v Found system, users must first register with an email ID. Any object that has been lost has to be photographed and has a brief description written by the individual who lost it. Users must register in the Simply Foundastic system with their email address in order to list lost goods with a brief description and a photograph[11]. This online application is not free. Anything that is lost by a person must be replaced to a touchpad with an integrated screen. We created a website where users may publish about persons who have been found and lost. It facilitates information transmission and retrieval and might be helpful in the application technique for item loss recovery. This user interface (UI) framework, which is computerised and open online, is simple to use and understand when compared to the standard manual approach[9][13].

VI. PROPOSED SYSTEM

- The network fits into the system or organization's overall framework.
- It entails comprehending the connections and interactions between the network and other stakeholders or components.
- A few necessities include integration with current systems, data management and privacy, reporting and analytics, user experience, maintenance, and support.
- A few necessities include integration with current systems, data management and privacy, reporting and analytics, user experience, maintenance, and support[12].

VII. TOOLS AND METHODOLOGY

Hardware Requirements:

CPU : INTEL PENTIUM D3.6GHZ OR HIGHER RAM : 2GB. HDD : 500gb

OS: any Linux distro or windows (for development) WEB BROWSER : CHROME VER.>100

Software Requirements:

Front end : Svelte, leaflet

Backend : node.js , express.js , sqlite3 , bcrypt . language used : javascript[14]

VIII. PROPOSED METHODOLOGY

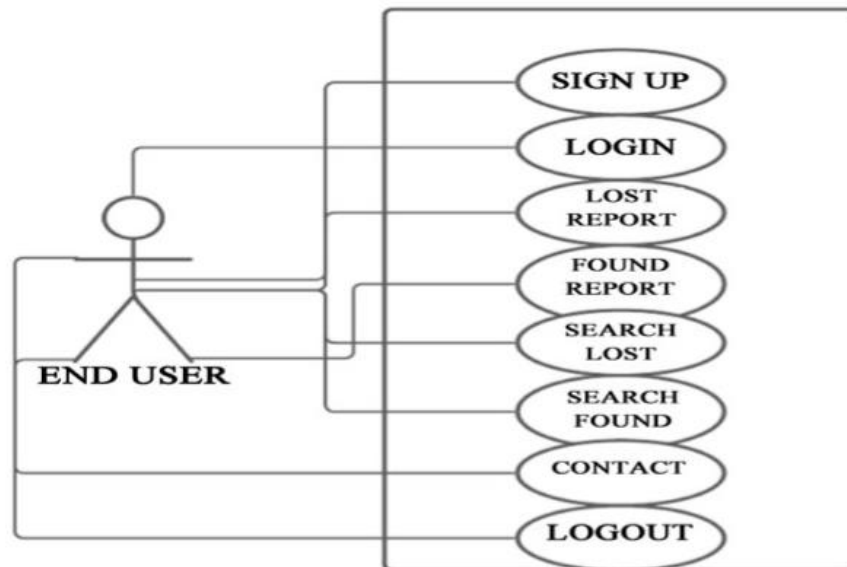

Fig.1 Architecture of our proposed method

- Login: Verify the user's credentials against the database's stored data while authenticating the user.
- Management of sessions: Establish a session for the authenticated user so they can access the website's restricted parts. Implement systems to deal with unsuccessful login attempts and display pertinent error messages.
- Unfound Report: Provide users with the option to provide details about the missing item, including its description and an optional image upload.
- Store report details: Save the lost item report and link it to the appropriate user account in a database. Implement validation tests to make sure the supplied information is accurate and full.
- Findings Report: Allow users to input details about a found item, including a description and an optional image upload, similarly to the Lost Report section.
- User's search criteria. Search results shown Display the user with the retrieved data while displaying the pertinent found item reports. Enable communication between users by giving users a way to get in touch with the owners of missing objects via the website.
- Privacy and security: Take steps to safeguard user privacy and stop the unauthorized use of contact information. Consider using email alerts to alert users to contact requests or updates to their reports of lost items.
- User final session: Remove all session-related data and end the active session. Specify the verification: Declare that the user has successfully logged out by displaying a message.

IX. RESULTS



Fig. 2 Login Page



Fig. 3 Tagging Location

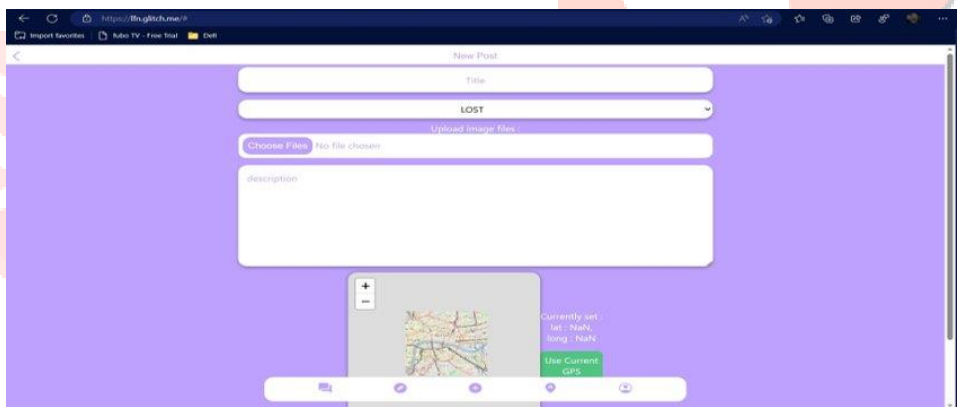

Fig. 4 Adding Post

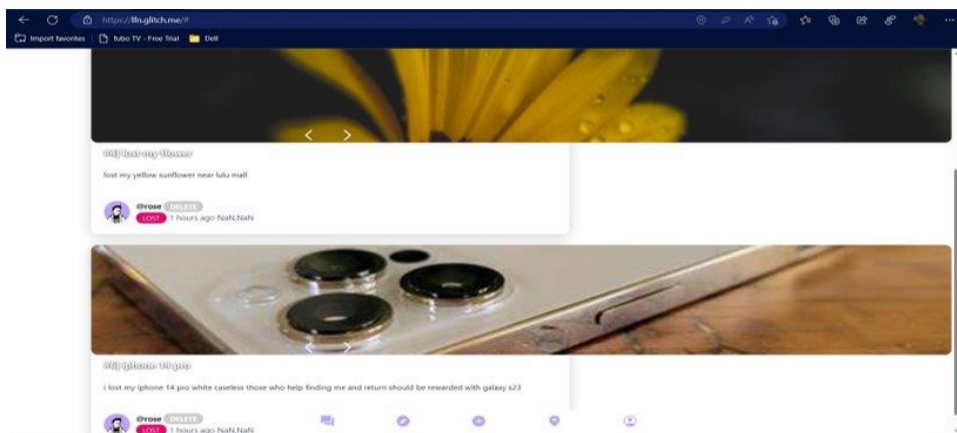

Fig. 5 Exploring Lost Post

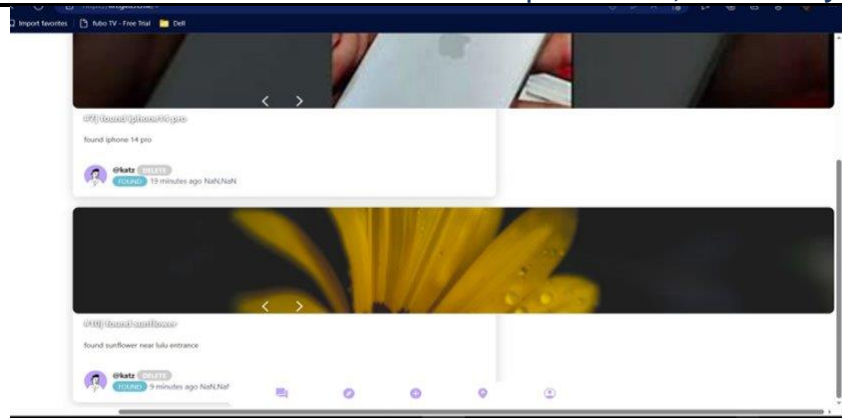

Fig. 6 Exploring Found Post

X. CONCLUSION

In conclusion, it has become clear from the development and usage of the community-driven platform for discovering lost items that it is helpful in resolving the lost property issue. Thanks to the platform's user-friendly design and adoption of cutting-edge technologies, people now have a trustworthy and efficient way to report lost things and hunt for missing possessions. The database's expansion and the effectiveness of reuniting lost goods with their owners serve as evidence of the platform's relevance as a digital hub for lost and found items. The usage of smart phone applications, augmented reality (AR), and internet of things (IoT) devices has enhanced user experience by allowing real-time tracking and providing innovative methods for locating lost objects. Insightful data regarding user activity and item patterns were offered by the analytics module, which was helpful to enhance the search procedure even further. By working together with law enforcement and transit networks, the system has become more successful across jurisdictions and modes of mobility. The platform has the potential for further growth, including blockchain integration and global network expansion, which increases its usefulness and potential influence[11]. This study has, in general, demonstrated the utility of technology in assisting individuals in finding their lost belongings, laying a solid platform for future development and widespread adoption

XI. FUTURE SCOPE

- Expansion into more locales: At the present, the platform only functions in one locale. Given the system's effectiveness and success, it would be good to expand its influence to other continents or possibly the entire planet. This would need establishing alliances and collaborations with a wide range of global networks and entities.
- Integration with smart home devices: Due to the growing appeal of smart home devices, users may find it more convenient if your platform is compatible with devices like smart speakers or smart displays. They might just notify them to misplaced items or report them using voice commands or visual interfaces.
- Integration with e-commerce platforms: Users may compare missing goods to found ones by collaborating with reputable e-commerce websites to put them up for sale.
- This integration may be able to identify lost items that are being sold again and aid in their recovery.
- Utilization of complex search algorithms: By continually refining the platform's search engines using machine learning and data mining methodologies, it is possible to increase the precision and efficacy of discovering missing items. If natural language processing is applied, users could be able to perform specialised descriptor searches or even submit photos for better matching.
- Collaborating with insurance companies: Using insurance companies as a partner might speed up the process of reporting and compensating users for missing products.
- Individuals who often use the site may also receive awards or discounts from insurance companies.
- Community participation and crowd sourcing. How well it works

XII. ACKNOWLEDGMENT

We would like to express our sincere gratitude to everyone who has assisted us in finishing this project. Due to a lack of knowledge and expertise, we encountered numerous difficulties while working on the project, but these individuals assisted us in overcoming all these obstacles and in the successful realisation of our plan to create a sculpture. We would like to express our gratitude to Asst. Prof. Mrs. Tessa Abraham for her guidance and Asst. Prof. Mrs. Mathu Uthaman for coordinating our project, which enabled our entire team to understand the minute details of project work. We would like to express our appreciation to our HOD, Mrs. Suma S. G., for her ongoing assistance and supervision during the project work. Finally, we would like to express our gratitude to the administration of Mahaguru Institute of Technology for giving us this learning opportunity.

XIII. REFERENCES

1. Agboola, B., & Shaibu, R. (2019). Impact of ICT on information retrieval system in academic libraries: the experience of Federal University Gashua Library, Yobe State, Nigeria. *Library Philosophy and Practice*, 1-15
2. Awotunde, J. B., Ogundokun, R. O., Ayo, F. E., Ajamu, G. J., Adeniyi, E. A., & Ogundokun, E. O. (2019, September). Social media acceptance and use among university students for learning purpose using UTAUT model. In *International Conference on Information Systems Architecture and Technology* (pp. 91-102). Springer, Cham. <http://doi.org/10.5281/zenodo.2646463>
3. Azad, H. K., & Deepak, A. (2019). Query expansion techniques for information retrieval: a survey. *Information Processing & Management*, 56(5), 1698-1735.
<https://doi.org/10.1016/j.ipm.2019.05.009>
4. Bachchhav K. P. (2016). Information retrieval: search process, techniques and strategies. *International Journal of Next Generation Library and Technologies (IJNGLT)* 2(1), 1-10.
5. Bataineh, E., Bataineh, B., & Kindi, S.A. (2015). Design, development and usability evaluation of an online web based lost and found system. *International Journal of Digital Information and Wireless Communications*, 5(2), 75-82.
6. Bolu-Steve, F. N., Oyeyemi, O. P., & Amali, I. O. O. (2015). Internal Usage and Academic Performance of Undergraduate Students in University of Ilorin, Nigeria. *Ethiopian Journal of Education & Sciences*, 11(1), 39-47.
7. Brandsen, A., Lambers, K., Verberne, S., & Wansleben, M. (2019). User Requirement Solicitation for an Information Retrieval System Applied to Dutch Grey Literature in the Archaeology Domain. *Journal of Computer Applications in Archaeology*, 2(1), 21-30.
<https://doi.org/10.5334/jcaa.33>
8. Gandal, N. (2001). The Dynamics of Competition in the Internet Search Engine Market. *International Journal of Industrial Organization*, 19(7), 1103-1117. [https://doi.org/10.1016/S0167-7187\(01\)00065-0](https://doi.org/10.1016/S0167-7187(01)00065-0)
9. Githinji S. M., (2016). Designing Lost and Found Web Applications, Based on Trusted Third-party Model. Retrieved from http://www.aitrec.org/wpcontent/uploads/2017/09/Designing_Lost_and_Found_Web_Application.pdf
10. Lashkari, A. H., Mahdavi, F., & Ghomi, V. (2009, April). A boolean model in information retrieval for search engines. In *2009 International Conference on Information Management and Engineering* (pp. 385-389). IEEE <https://doi.org/10.1109/ICIME.2009.101>
11. Lost and Found Kenya. (2014). Lost and Found Documents Centre. Retrieved from <https://www.facebook.com/lostandfounddcKenya/> and <https://placesmap.net/KE/Lost-And-Found-DocumentsCentre-646961292135175/>
12. Madankar, M., Chandak, M. B., & Chavhan, N. (2016). Information retrieval system and machine translation:

13. Njuguna, D. (2018). Lost Documents Retrieval Management System. Kabarak University, (pp 1-38).<http://doi.org/10.13140/RG.2.29634.27841>
14. Ogundokun, R. O., Adebisi, M. O., Abikoye, O. C., Oladele, T. O., Lukman, A. F., Adeniyi, A. E., ... Akande, N.O. (2019a). Evaluation of the scholastic performance of students in 12 programs from a private university in the south-west geopolitical zone in Nigeria (Version 1; Peer review: 3 approved with reservations). F1000 Research, 8:154. <https://doi.org/10.12688/f1000research.16762.1>

