



INTERNATIONAL JOURNAL OF CREATIVE RESEARCH THOUGHTS (IJCRT)

An International Open Access, Peer-reviewed, Refereed Journal

Review Of Layout & Implementation Of A Low Cost Statistics Logger For Solar Home Device

Mr. Arun S. Dadas*¹, Aniket S.Dhubal*², Prof.Suraj S. Shinde*³

*^{1,2},Students Dept. Of Electrical Engineering, SMSMPITR, Solapur University, Maharashtra, India.

*³,Asst.Professor, Dept. Of Electrical Engineering, SMSMPITR,Akluj, Maharashtra, India.

ABSTRACT

The demand of electric power is increasing gradually with the advancement of modern technology & engineering. Because the demand of electricity in urban areas or in industrial zones is large in amount & also more important than the rural areas, there exists a shortage of electric power supply facilities for rural households or remote location from the cities. In this case, Solar Energy is a promising solution to meet the demand for electricity services of rural areas in developing countries like Bangladesh. The effectiveness & stability of small PV systems for rural development is needed to be monitored for successful installment of Solar Panel. In order to analyze the system & modify it for cost reduction a data capturing unit should be constructed that can store the voltages & currents

at three different terminals. A microcontroller operated Smart Data Logger can perform this work with high accuracy & precision maintaining the system cost much less than the conventional system. This paper deals with the design and implementation of a low cost data logger for solar home system. An experimental set up is designed and implemented and the paper illustrates the working principle, data observation and analysis, limitations, and future aspects of a low cost data logger for solar home system.

Keywords-- Solar System, SHS, PV Panel

I. INTRODUCTION

Energy, or electrical power, plays a vital part in modern civilisation, and the availability of energy for businesses and human civilization is critical to the proper development of a nation. As a result, energy or power is a critical component of a country's socioeconomic development. The world's energy consumption is rapidly increasing as a result of rapid urbanisation and technological advancement. Global energy consumption is expected to rise by 28% between 2015 and 2040, according to the US Energy Information Administration (EIA). It will rise from 575 quadrillion British thermal units (Btu) in 2015 to 663 quadrillion Btu in 2030 and 736 quadrillion Btu in 2040 [1].

The primary sources of energy are fossil fuels and oil. Within the next two or three decades, the world's complete reserve of this fossil fuel will be depleted. For improved human sustainability, the mono-dependency policy on fossil fuels must be reduced. Furthermore, these fuels contribute to greenhouse gas emissions and a high carbon footprint. So, in order for the human world to continue to exist, a reliable and economical alternative energy source must be discovered. In addition, it is necessary to ensure that all people around the world have access to power. Humans all across the world demand power or electricity for both economic and social progress. Examine previously published work in the same area.

II SOLAR ENERGY DEFINITION

Solar energy is the radiant light and heat from the Sun that is captured by a variety of ever-evolving technologies like solar heating, photovoltaic, solar thermal energy, solar architecture, molten salt power plants, and artificial photosynthesis. It is an important source of renewable energy, and depending on how it captures and distributes solar energy or converts it to solar power, its technologies are classified as passive or active solar.

III IMPORTANCE OF THE SOLAR PANEL

Solar power systems harness the sun's clean, pure energy. Installing solar panels on your home helps to reduce greenhouse gas emissions and our reliance on fossil fuels as a whole. Electricity is traditionally generated using fossil fuels like coal and natural gas. Renewable energy is also good for people's health.

IV LOW-COST DATA LOGGER FOR SOLAR RESIDENTIAL SYSTEMS

Solar Home System requires real-time data storage for future analysis and processing. It enables the system to keep track on the system's stability and correctness. With the advancement of information technology and electronics, it may be able to save diverse real-time data from the system on a micro SD card without experiencing any delays. The majority of modern systems require data to be retained for later examination. Data is no longer to be continuously transferred to a distant server. Data transmission in real time necessitates additional power, expense, and hardware.

Circuitry for interfacing software. If data for several days has been recorded locally, it can be utilised to estimate the current state of the system. Whereas a traditional Data Logger or real-time monitoring device costs more due to the advanced transmission technique, a Smart data recorder connected to a Solar Home System may accomplish all of the same monitoring and data storage for a fraction of the cost. A method is being created to detect these data and deliver it to a micro SD card, where it will be stored. For data storage, an automatic text file is created. The system design and verification process is very cost-effective, i.e. the entire cost is maintained as low as feasible. In undeveloped nations, solar PV household applications are limited to the following three systems.

- Small PV system having one or more solar PV modules and a battery with a total peak output of 200W or less. Household items such as lights, radios, televisions, and fans are powered by them.
- Solar lanterns are made up of a PV module and a battery-powered light.
- PV battery charging stations feature a number of PV modules that are used to charge individual household batteries. These may be used to power home systems and lamps on the go.
- The Smart Data logger can be used to estimate the working state of any of the three systems mentioned above.

V.SYSTEM DESIGN & SETUP

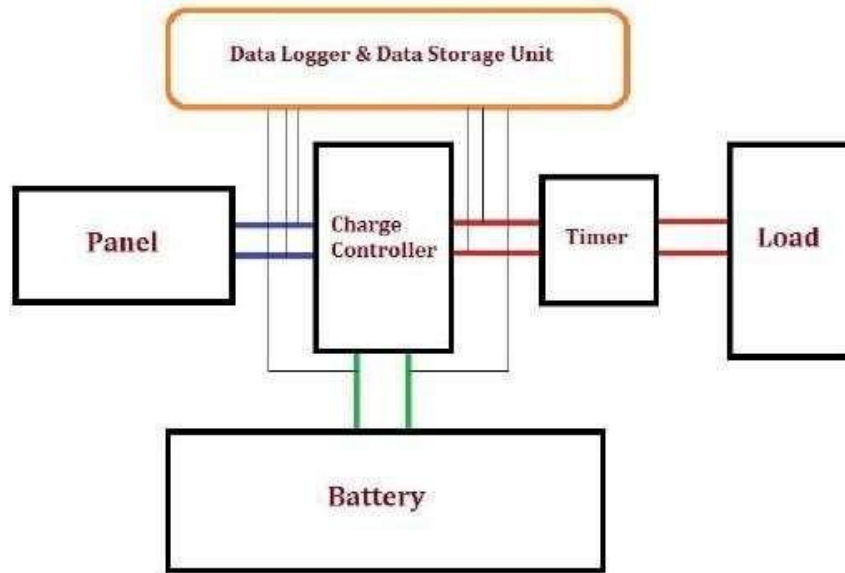

Fig- 1 Complete diagram of the system

Components of the System

The overall system is composed of some basic elements

- ☐ Solar Panel
- ☐ Real Time Clock ;
- ☐ SD Card Module
- ☐ TFT
- ☐ Buck Regulator
- ☐ Solar Charge Controller
- ☐ Battery
- ☐ System Load
- ☐ Microcontroller (Arduino Mega)
- ☐ Analog Voltage & Current sensors



Major Parts Of System

A SHS consists of mainly three major parts. They are the following:

- 1) Pico-solar panel
- 2) Charge controller and
- 3) Rechargeable battery

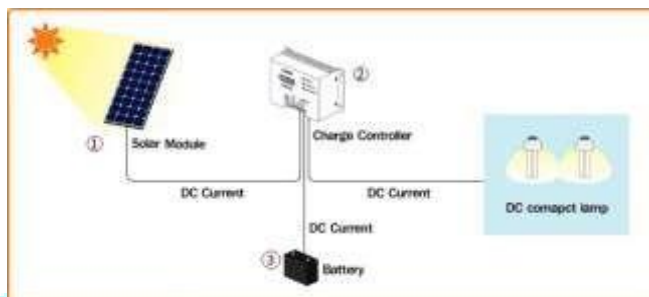

Figure 2: Different Components of Solar Home System

Pico-Solar Panel:

Solar home systems use photovoltaic (PV) cells and this PV cells are made from semiconductor materials such as silicon and generate DC electricity from sunlight. A different number of cells according to the size of PV are connected together and sealed in a waterproof case which called PV panel. Figure 2-4 presents a small PV panel which is called Pico-Solar panel. These pico-solar panels range from 0.1 Watt-peak to 20 Watt-peak



Figure 3: Pico-Solar Panel Set Up on the House Roof

The watt-peak (Wp) rating of PV cells and panels describes their capacity, and the generation is determined by this capacity under typical conditions and weather. Solar house systems typically use 20 Wp or 30 Wp PV systems, however systems with higher capacity, such as 40, 50, 60, 100, and 130 Wp, are also available depending on the load.

Hardware Model

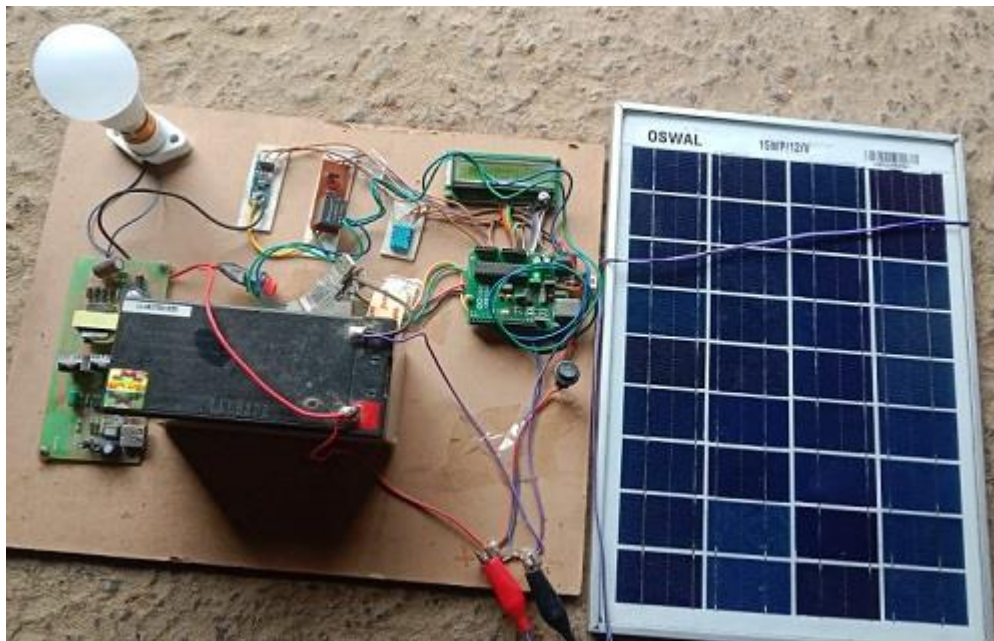

Fig 4 .Solar Model

Charge Controller

Job is to keep the voltage and current from the solar PV panel to the battery in check so that overcharging doesn't happen. over-discharging. Many technologies have been included in the design of a solar charge controller. For example, MPPT charge controller included maximum power point tracking algorithm to optimize the production of the PV cell or panel. Figure 2-5 shows a charge controller for SHS.

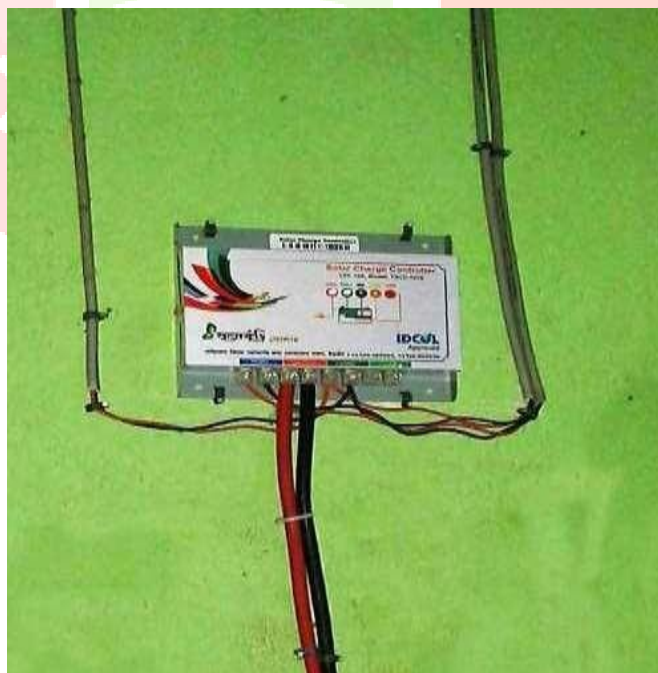

Fig 5. Pico-Solar Charge Controller Setup in the House wall

VI.RESULT & CONCLUSION

A data logger and monitoring system are essential for the smooth, efficient, and reliable operation of a PV solar energy system. The datalogger and monitoring system ensures correct operation and helps to uncover system malfunctions before they become big problems. With a data logger, it becomes very straightforward to trace any given data across a certain time period, resulting in an easily traceable scenario for finding any operational irregularities. To provide a low-cost, user-friendly and easy access non-commercial monitoring system, an Android application is developed for pico solar energy system monitoring for rural electrification program in developing countries like Bangladesh. This App is developed using an open source-based software call MIT App Inventor which is basically a drag and drop software development tool. This developed Android App shows all PV parameters in a plot in the real-time form. It has a special feature to send a text message to maintenance personnel if the battery voltage goes beyond a threshold value.

VII. REFERENCES

1. J. Conti, P. Holtberg, J. Diefenderfer, A. LaRose, J. Turnure and L. Westfall, "International Energy Outlook 2017 With Projections to 2040 (No. DOE/EIA- 0484 (2017))-U.S. Energy Information Administration (EIA).[Online]. Available:[https://www.eia.gov/outlooks/aeo/pdf/0383\(2017\).pdf](https://www.eia.gov/outlooks/aeo/pdf/0383(2017).pdf) [Accessed: 09-Dec-2017].
2. International Energy outlook 2017 Energy Information Administration (EIA) available: [https://www.eia.gov/outlooks/ieo/pdf/0484\(2017\).pdf](https://www.eia.gov/outlooks/ieo/pdf/0484(2017).pdf)
3. C. Ranhotigamage and S. C. Mukhopadhyay, "Field Trials and Performance Monitoring of Distributed Solar Panels Using a Low-Cost Wireless Sensors Network for Domestic Applications," IEEE Sensors Journal, vol. 11, no. 10, pp. 2583–2590, 2011
4. A. Chouder, S. Silvestre, B. Taghezouit, and E. Karatepe, "Monitoring, modelling and simulation of PV systems using LabVIEW," Solar Energy, vol. 91, pp. 337– 349, 2013.
5. F. Shariff, N. A. Rahim and W. P. Hew, "Zigbee-based data acquisition system for online monitoring of grid-connected photovoltaic system", Expert Systems with Applications 42, no. 3, pp. 1730-1742, 2015.
6. AllegroMicroSystems, "ACS712 Current SensorIC"[Online]. Available:https://www.digikey.ca/en/product-highlight/a/allegro-microsystems/acs712-current-sensoric?utm_adgroup=General&mkwid=syTHaZJD9&pcrid=87194135825&pkw=&pmt=b&pdv=c&gclid=Cj0KCQjw8MvWBRC8ARIsAOFsVBWNT-gEydrA-K_KEW7zIK49852OnOC9-eg6BXHFG-uP-O3Jsguu6VcaAv8BEALw_wcB.
7. "Voltage Sensor 25V Arduino: Best Price in Malaysia," Lelong.my. [Online]. Available: <https://www.lelong.com.my/voltage-sensor-25v-arduino-jfrtech192744393-2018-05-Sale-P.htm>. [Accessed: 17- Apr-2018]
8. Arduino - Software. [Online]. Available: <http://arduino.cc/en/Main/Software#toc4>