



Wild Animal Detection And Identification Using Deep Learning

¹Prof. D. D. Pukale, ²Komal Dudhane, ³Shreya Dawghat, ⁴Anushka Deshmukh,

⁵Sharwari Deshmukh.

¹Professor, ²Student, ³Student, ⁴Student, ⁵Student^{1,2,3,4,5}

Department of Computer Engineering,

^{1,2,3,4,5} Bharati Vidyapeeth College of Engineering for Women, Maharashtra, India

Abstract: Now a days, object discovery is used encyclopedically in multitudinous fields similar as, videotape surveillance, rambler displays, vilification discovery, tone- driving buses and appearance recognition etc. Efficient and reliable monitoring of wild animals in their natural habitats is essential to inform conservation and management decisions. Since there are large number of different animals, manually relating them can be a delicate task. So, it's delicate to classify animals grounded on their images and cover them more efficiently. Also, it's important to make a count of animals as they're being defunct now a days, so to save them we've to keep a note duly so that we can take important measures to save them. In being system there's only homemade checking where a mortal being need to present to keep a count of animals. Which take so much of time to identify the animals. To overcome those problems, we're introducing an automatic relating and counting the animals by using deep learning methods. This process gives an accurate result to detects and keep proper count of animals.

Keywords: Animal Detection and Classification, Deep Learning Algorithms.

I. INTRODUCTION

Wildlife viewing in their natural environment is central to ecology. The speedy increase of human population and the limitless pursuit of financial improvement are making over-exploitation of natural resources, inflicting rapid, novel and substantial adjustments to Earth's ecosystems. A growing area of land surface has been changed with the aid of human action, altering wildlife population, habitat and behavior.

More seriously, many wildlife species on Earth have been brought to extinction, and many species are introduced into new areas where they can disrupt both nature and human system. Monitoring wild animals, therefore, is necessary as it presents researchers evidences to inform conservation and administration decisions to maintain diverse, balanced and sustainable ecosystems in the face of those modifications.

Various up-to-date technologies have happened grown for wild animal listening, including radio tracking , wireless sensor network tracking , satellite and global positioning system (GPS) tracking , and monitoring by motion sensitive camera traps . Motion-triggered remote cameras or "camera traps" are an increasingly popular tool for wildlife monitoring, due to their novel features equipped, wider commercial availability, and the ease of deployment and operation. Once being sufficiently loaded, a camera can snap millenaries of successive representations, providing a big volume of data. These requirements form camera traps an effective form for ecologists as they can document each facet of wildlife.

Visual info, if maybe captured, is a rich beginning of information that specify scientists evidences to answer conservation – accompanying scientific questions to a degree: what are the relating to space distributions of rare animals, that variety are being threatened and need guardianship in the way that bandicoot, that follower of pest class, in the way that red deceive and animal, need expected controlled; these are models of key questions to accept wild animals' societies, ecological connections and public dynamics. To this end, a currently widely worn approach by ecologists be going to set up various camera traps in the wild to accumulate concept data of wild animals in their natural residences.

Camera trapping is swiftly being approved for being monitoring on account of advances in digital technology that produce more up-to-date camera traps accompanying automation of system elements but lower cost of purchase; the task of resolving massive accumulations of camera trap images, still, has happened attended manually. Despite the fact that human visual structure can process images easily and swiftly, deal with specific a tremendous number of images manually is much expensive. For example, to date, the Snapshot Serengeti project¹ collected 3.2 ton images through 225 camera traps across the Serengeti National Park, Tanzania from 2010–2013. Another identical project, Wildlife Spotter², collected lots photos of being caught in tropical rainforests and dry rangelands of Australia. Unfortunately, on account of automatic trap camera snapping system, the far-reaching plurality of grabbed images is questioning to process, even for human. Only a restricted number of collected images are in good condition. Furthermore, numerous images are in grayscale as they were picked up each evening accompanying shade resembling, and a a lot of representations holds no animal (75% of the Snapshot Serengeti [8] and 32.26% of Wildlife Spotter marked concepts were top-secret as “no animal”), while in others power perform various objects owned by various variety

II. LITERATURE SURVEY

The Literature Concerned with “Animal Detection in Man-made Environments” is reviewed in this paper which is written by Abhijeet Singh, Marcin Pietrasik, Gabriell Natha, Nehla Ghouaiel, Ken Brizel, Nilanjan Ray. This research paper addresses the aforementioned challenge by employing deep learning methodologies derived from diverse domains of computer vision, such as object detection, segmentation, tracking, and edge detection. Notably, valuable findings regarding the applicability of transfer learning are uncovered as the authors adapt models trained on standardized datasets for practical implementation in real-world scenarios.

“Towards Automatic Wild Animal Detection in Low Quality Camera-Trap Images Using Two Channelled Perceiving Residual Pyramid Networks” this paper presented by Chunbiao Zhu; Thomas H. Li; Ge Li in which propose a novel approach called Two-Channel Perceiving Residual Pyramid Networks (TPRPN) specifically designed for object detection in camera-trap images. The TPRPN model is meticulously crafted to produce high-resolution and high-quality detection outputs. To ensure ample local information is captured, we extract depth cues from the original images and employ a two-channel perceiving model as input during network training. Notably, our proposed architecture incorporates three-layer residual blocks that effectively amalgamate all available information and generate comprehensive detection results at full size. Additionally, we curate a new and high-quality dataset in collaboration with Wildlife Thailand's Community and eMammal Organization. Empirical evaluations conducted on our dataset substantiate the superiority of our method compared to existing object detection approaches.

According to Mina Gabriel, Sangwhan Cha, Nushwan Yousif B. Al-Nakash, and Daqing Yun. In the paper “Wildlife Detection and Recognition in Digital Images Using YOLOv3” This study investigates the utilization of modern hardware capabilities and machine learning techniques to facilitate the convenient monitoring of wildlife and their habitats. The researchers employ Deep Learning (DL) methodologies to detect and identify wildlife species in digital images, and they present the outcomes of their experiments conducted on a readily available workstation. Specifically, they utilize YOLOv3 and YOLOv3-Tiny models for the detection and classification of various animal classes using a dataset comprising 9,051 digital images. Remarkably, the achieved mean average precision (MAP) scores for YOLOv3 and YOLOv3-Tiny are reported as 75.2% and 68.4%, respectively.

The paper “You Only Look Once: Unified, Real-Time Object Detection” written by Redmon, Joseph; Divvala, Santosh; Girshick, Ross; Farhadi, Ali introduces YOLO, an innovative approach to object detection that differs from previous methods that repurpose classifiers for detection purposes. Instead, YOLO formulates object detection as a regression problem, predicting separate bounding boxes and corresponding class probabilities. This unified architecture enables end-to-end optimization directly on detection performance since the entire detection pipeline operates within a single neural network. Notably, YOLO exhibits exceptional speed, with the base model processing images in real-time at an impressive rate of 45 frames per second. Even the smaller variant, Fast YOLO, achieves an astonishing speed of 155 frames per second while surpassing the mean average precision (mAP) of other real-time detectors. Although YOLO may have more localization errors compared to state-of-the-art systems, it demonstrates a lower tendency to generate false positives on background. Additionally, YOLO learns highly versatile object representations, outperforming alternative detection methods, such as DPM and R-CNN, when applied to diverse domains such as artwork, highlighting its generalization capabilities.

In “Image Detection and Recognition of different species of animals using Deep Learning” authors R. Shanthakumari, C. Nalini, S. Vinothkumar, B. Govindaraj contains Deep Learning has gained significant traction as a solution for addressing challenges in computer vision. Recent literature showcases the growing efficiency of deep learning models in tackling complex real-world problems. Nonetheless, training these networks can be time-consuming and expensive, particularly in scenarios where real-time applications are involved. It becomes imperative to explore methods for swiftly collecting data to enable real-time applications. In light of increasing awareness regarding habitat conservation, researchers are investigating animal density, presence, and absence to assess the visibility of endangered species. Efficient animal detection tools are essential for estimating and monitoring animal populations in specific areas, a crucial aspect of environmental monitoring. Camera-based technologies, alongside acoustic and seismic measures, can be leveraged for animal detection. Cameras have a long-standing history of usage as valuable tools for wildlife behavior monitoring and ecosystem assessment.

“Convolutional Network based Animal Recognition using YOLO and Darknet” authored by B. Karthikeya Reddy, Shahana Bano, G. Greeshmanth Reddy, Rakesh Kommineni, and P. Yaswanth Reddy presents a solution to the arduous task of manually identifying animals along with their names. To address this challenge, the researchers propose a YOLOv3 model that effectively recognizes animals depicted in user-provided images. The YOLOv3 model leverages the darknet algorithm, benefiting from a pre-trained dataset. The model's performance is evaluated based on distinct training and testing images within the dataset. The primary objective of this research is to establish an animal recognition methodology utilizing the YOLOv3 model. Given an input image of an animal, the model accurately outputs the corresponding animal name. The detection process is facilitated by employing a pre-trained coco dataset obtained from darknet.

III. System Design

In this section, we present the design goals and architectural components.

A. Design Goals

- i. **Availability:** The system shall be available during 24 hours of a day.
- ii. **Usability:** The system is designed keeping in mind the usability issues considering the end-users who are developers/programmers. It provides detailed help which would lead to better and faster learning. Navigation of system is easy.
- iii. **Consistency:** Uniformity in layout, screens, Menus, colors scheme, format.
- iv. **Performance:** The performance of the system should be fast and as per user requirement. From this system we will get expected outcome in less time and less space since efficiency is higher. Speed is totally depending on the response of the database and connection type.
- v. **Extendibility:** Prevention in the system should be done in the system by which we make changes in the system later on.
- vi. **Reusability:** Files of any type can be used by the system for any number of times during transformation.
- vii. **Reliability:** Protection of data from malicious attack or unauthorized access.

- viii. **Security:** The system provides security to the randomly generated private key by performing encryption to it for encrypting patient data and thus protects from other nodes in the network. The network is free from malicious node and misbehaving node attacks.
- ix. **Reliability:** Our system can provide user an efficient search each time. So, the user can reliable on the system. Because system can guarantee user to provide his/her interested data every time in least amount of time.

B. Architectural Component

YOLOv3 (You Only Look Once, Version 3) is a real-time object detection algorithm that identifies specific objects in videos, live feeds, or images. The YOLO machine learning algorithm uses features learned by a deep convolutional neural network to detect an object. YOLO divides an input image into an $S \times S$ grid. If the center of an object falls into a grid cell, that grid cell is responsible for detecting that object. Each grid cell predicts B bounding boxes and confidence scores for those boxes. Inspired by ResNet and FPN (Feature-Pyramid Network) architectures, YOLOV3 feature extractor, called Darknet-53 (it has 52 convolutions) contains skip connections (like ResNet) and 3 prediction heads (like FPN) — each processing the image at a different spatial compression.

Methodology

- **Dataset** - Offer a dataset for a machine that does not see data the same way that people do, the data acquired should be made standard and intelligible. The video data set that was used in this study is a collection of videos of diverse animals. The dataset is divided between train and test groups at a ratio of 80:20.
- **Pre-processing:** Pre-processing is necessary because real-world data frequently has noise, missing values, and may even be in an unusable format that prevents it from being used directly by machine learning models. Data pre-processing is necessary to clean the data and prepare it for a machine learning model, which also improves the model's accuracy and effectiveness.
- **Feature Extraction** - By generating new features from the old ones (and subsequently deleting the original features), feature extraction tries to decrease the number of features in a dataset. The majority of the data in the original collection of features should then be able to be summarized by this new, smaller set of features.
- **Classification** - The Classification method uses supervised learning to categorize fresh observations in light of training data. In classification, a computer learns from the dataset or observations that are provided and subsequently divides fresh observations into several classes or groups.

System Architecture

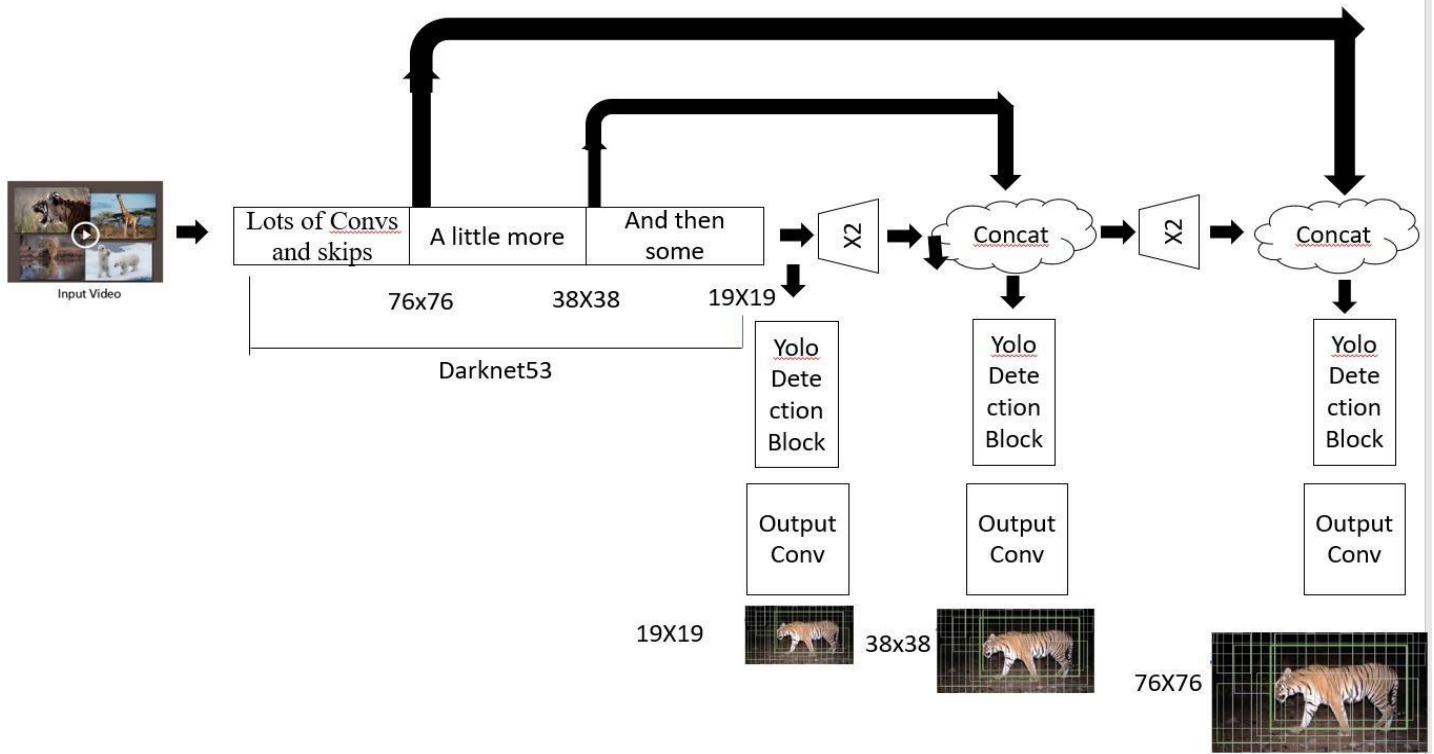

Motivation

The identification and categorization of animal species are critical areas that demand efficient approaches, as they contribute to mitigating wildlife-related traffic accidents, which often lead to fatalities and injuries. Furthermore, these methods enhance human comprehension of biodiversity. Attacks by animals are a significant cause of human fatalities and injuries in many instances.

Result



Labeling Name	TRAIN set	TEST set
Zebra	150	50
Deer	150	50
Tiger	250	70
Elephant	180	50
Giraffe	80	20

Label	Average Precision	True Positive	False Positive
Zebra	97.48%	54	4
Deer	96.20%	35	5
Tiger	100%	88	0
Elephant	98.53%	67	1
Giraffe	92%	73	4

- $\text{conf_thresh} = 0.25$
 - $\text{precision} = 0.97$
 - $\text{recall} = 0.96$,
 - $\text{F1-score} = 0.96$ for $\text{conf_thresh} = 0.25$,
 - $\text{TP} = 317$,
 - $\text{FP} = 11$,
 - $\text{FN} = 13$, average
 - $\text{IoU} = 73.45\%$
 - $\text{IoU threshold} = 50\%$,
- used Area-Under-Curve for each unique Recall mean average precision ($\text{mAP}@0.50$) = 0.968409, or 96.84 %
- Total Detection Time: 8 Seconds.

CONCLUSION

The present systematic investigation has yielded the following findings: The research undertaken focuses on leveraging yolov3 Machine Learning models and associated techniques to predict and count animals. Among the myriad applications of video processing, the identification of animals emerges as particularly impactful. Given the vast diversity of animal species, manual classification can prove to be a painstaking endeavor. To mitigate the time and cost associated with manual predictions, it is beneficial to assess the likelihood of obtaining accurate results based on existing research and their corresponding success rates. A key advantage lies in the precise identification of animals. Based on the outcomes documented in the scrutinized research papers, yolov3 demonstrates exceptional accuracy in animal identification.

REFERENCES

Here are the references used in the writing of this paper:

1. Mina Gabriel, Sangwhan Cha, Nushwan Yousif B. Al-Nakash, and Daqing Yun Wildlife Detection and Recognition in Digital Images Using YOLOv3, 15 Dec. 2020
2. Abhijeet Singh, Marcin Pietrasik, Gabriell Natha, Nehla Ghouaiel, Ken Brizel, Nilanjan Ray. Animal Detection in Man-made Environments, 2020.
3. Chunbiao Zhu; Thomas H. Li; Ge Li, "Towards Automatic Wild Animal Detection in Low Quality Camera-Trap Images Using Two-Channelled Perceiving Residual Pyramid Networks", 2019.
4. Redmon, Joseph; Divvala, Santosh; Girshick, Ross; Farhadi, Ali. You Only Look Once: Unified, Real-Time Object Detection, IEEE 2016 IEEE Conference on Computer Vision and Pattern Recognition (CVPR) - Las Vegas, NV, USA (2016.6.27- 2016.6.30)]
5. R. Shanthakumari, C. Nalini, S. Vinothkumar, B. Govindaraj. Image Detection and Recognition of different species of animals using Deep Learning, April 2022.
6. B. Karthikeya Reddy, Shahana Bano, G. Greeshmanth Reddy, Rakesh Kommineni, P. Yaswanth Reddy. Convolutional Network based Animal Recognition using YOLO and Darknet, 2021
7. Harish Kalla, Balachandran Ruthramurthy, Satyasis Mishra, Gemechu Dengia, Sarankumar R.A Practical Animal Detection and Collision Avoidance System Using Deep Learning Model, IEEE July 2022 10.1109/I2CT54291.2022.9824594
8. Z. Zhao et al, "Object detection with deep learning: A review," IEEE Trans. Neural Netw. Learn. Syst., vol. 30, no. 11, pp. 3212–3232, 2019
9. Michal Maj "Object detection and Image Classification with YOLO" KDnuggets, September 2018.
10. Sreedevi K L, Anitha Edison. Wild Animal Detection using Deep learning, February 2023, IEE 10.1109/INDICON56171.2022.10039799
11. Z. Zhang, Z. He, G. Cao and W. Cao, "Animal Detection from Highly Cluttered Natural Scenes Using Spatiotemporal Object Region Proposals and Patch Verification", IEEE Transactions on Multimedia, vol. 18, no. 10, pp. 2079-2092, Oct. 2016