



# INTERNATIONAL JOURNAL OF CREATIVE RESEARCH THOUGHTS (IJCRT)

An International Open Access, Peer-reviewed, Refereed Journal

## HYBRID SOURCE POWER SYSTEM OPTIMIZATION FOR MICRO GRID

SARAVANAN R,  
ME POWER SYSTEM,  
SONA COLLEGE OF TECHNOLOGY.

Dr.D. PRASAD ME., PH.D,  
ASSISTANT PROFESSOR,  
DEPARTMENT OF EEE,  
SONA COLLEGE OF TECHNOLOGY.

Dr.R. SATHEESH KUMAR, ME., PHD,  
ASSISTANT PROFESSOR,  
DEPARTMENT OF EEE,  
SONA COLLEGE OF TECHNOLOGY.

### ABSTRACT

In this paper power converter with multiple operating mode .the design of three independent power converters is often needed traditional distributed power converter. It designs of bi-direction of DC-DC, AC-DC, DC-AC converter operations. The operation of proposed system is control using pulse given to breaker to achieve the required operation. The pulse signals given to circuit breaker and MOSFET switches is accordingly and it is controlled by teaching and learning optimization technique. TLBO technique is proposed to solve constrained in design optimization problem with the parameters involved in variable objective function for the given system to attain the best value of objective function. The proposed system output made to give to EV charging port and battery further to test stability of system. Buck and boost operation, ac to dc, dc to ac modes are operating mode of multi-mode converter with TLBO algorithm is developed in MATLAB-Simulink environment. Experimental results suggest the proposed converter model with controller better response for EVs vehicles based on solar PV source charging.

Keywords: multi-mode converter, TLBO, MATLAB, Converter, EV Charging, PV panel.

### 1.INTRODUCTION

One of the main contributors of the greenhouse effect is carbon dioxide (co<sub>2</sub>) from gasoline and diesel engine vehicle exhaust. Electric vehicles (EVs) are expected to be a significant development in the auto-mobile industry in the future because they reduce CO<sub>2</sub> emissions. Because we need to develop the energy storage system and battery management system, hybrid energy sources can be used in electric vehicles. To achieve DC/DC converter voltage matching, lithium-ion batteries or fuel cells are employed as the primary power source, which is supplemented by a super capacitor or battery pack as an auxiliary power source because they typically have different voltage levels. We must first charge the battery pack, after which the rectifier will charge the battery. Rectifier is something we're familiar with

As a result, the inverter circuit that converts DC to AC must also have a grid connection function, allowing EVs to be fed back to the grid after the battery is fully charged. It aids peak shifting and regulation for the parking grid's idle EVs. The DC-DC converter is used in hybrid energy storage systems, photovoltaic systems, and fuel cell systems, among other applications. energy storage system DC power level conversion. One of the DC-DC converter topologies is Interleaved. The main advantage of interleaved DC-DC topologies is the lower out current ripple and increased power density. These interleaved topologies might be two, three, or multi-phase in nature. Another significant benefit of DC-DC interleaved topologies is that they are smaller and lighter than standard bi-directional DC-DC converters, and the rectification (AC-DC) process is improved. A unique filter circuit maintains power factor correction. Traditional power correction methods include adding a boost converter behind the rectifier bridge, but this method necessitates the use of a rectifier bridge and boost

circuit, both of which have a low conversion efficiency. To improve conversion efficiency, researchers presented a bridgeless power factor correction topology that eliminates the requirement for a rectifier bridge, and figured out how to solve the EMI problem by adding two additional diodes. Another alternative is bridgeless PFC with totem pole topology, which drives two bridge switches to independently drive the circuit without the need for additional power elements. For DC/AC inverters, there are three basic topologies. One is the push-pull configuration, which has a limited number of power devices and is simple to operate. However, due to the structural characteristics of the circuit, the push-pull circuit architecture cannot produce sinusoidal voltage waves, therefore it is only suitable for low-power and tiny applications. The next inverter is a half bridge topology inverter, which has a simple structure and a small number of switching components. However, the rated current of its power switch is double that of the power components in a full-bridge inverter circuit with high current stress. Final one is the full-bridge inverter circuit, whose output current and current via switching components are both half of the bridge inverter circuit. Due to the inclusion of four switching devices, the full-bridge inverter's driving circuit is more complex than the two prior topologies. The standard distributed power converter (DPC) strategy in EVs with hybrid energy storage systems requires at least three separate BI-DC-DC, AC-DC, and DC/AC converters. The buck converter and boost converter are used to convert power between the battery pack and the auxiliary energy when driving an electric vehicle. To power the electric appliances, an AC/DC converter is required. A multipurpose power converter system with a motor driven and battery charger has been researched by several researchers. To enable AC/DC conversion and share the power device of the motor controller, proposed a multi-input power converter to accomplish diverse operation modes by sharing the power devices of a boost DC/DC converter integrated the AC/DC charger of a battery basis of a DC/DC converter. Previous research on power converters has primarily focused on their performance, with only DC/DC and AC/DC integration being cited in the literature for integration converters. This study proposes a revolutionary integrated multi-function converter that includes BI-DC/DC, AC/DC, and DC/AC, as opposed to typical converters. The given PCMM, which is based on the BI-DC/DC architecture, adds only one switch and an AC capacitor to achieve multi-function operation, shares the inductor and capacitor, and MOSFET module, and provides three conversion functions while reducing system weight. This study introduces the concept of a power converter multi-mode (PCMM) and creates the model of the system using a TLBO Algorithm (Teaching and learning based optimization). The PCMM's experimental evaluation is described in this section. FIGURE depicts the topology of this system. 1. Each converter requires individual radiators, which are architecturally complex and costly.

## BLOCK DIGRAM

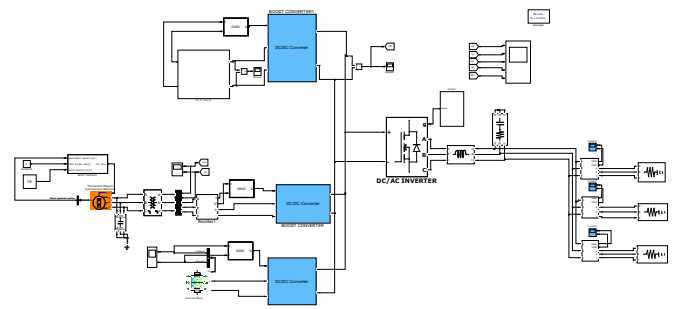

FIGURE .1 Proposed FeedbackSystem

## 2.TOPOLOGY AND DESIGN

The proposed PCMM's topology consists of four MOSFETs. PICTURE 2 The upper pair consists of Q1 and Q2. MOSFETs with lower pair Q3 and Q4 are known as lower pair MOSFETs. The switch labelled as S1,S2,S3,S4,S5 circuit breaker can be used to select different modes of operation. VL denotes the low voltage gain DC voltage on the auxiliary battery side, while VH denotes the high voltage DC voltage on the primary battery side..

To make the PCMM act as a bidirectional DC-DC converter, flip on switch k1. Switches k2 and k3 will be turned off during this operation, and the mode with interleaved topology will have a pair of buck and boost converters. When the upper pair of MOSFETs acts as a switch in a buck converter, the upper and lower MOSFETs operate as switches in a boost converter. Switch k1 and k2 off when the system is in AC-DC converter mode, and energy flows from the battery to residential/grid/AC loads when the system is in DC-AC converter mode. The TLBO algorithm chooses between charging mode and V2h mode.

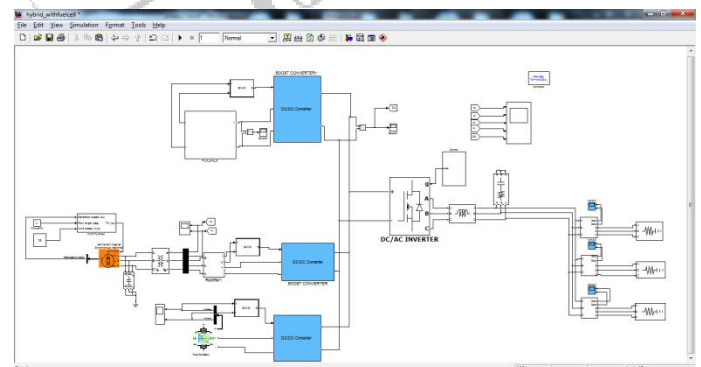

FIGURE. 2PROPOSED PCMM TOPOLOGY

The PCMM operates in Bi-DC/DC mode when the vehicle is in motion. The controller distributes power to the battery and auxiliary energy source based on the inverter's power needs. When the PCMM is in boost mode, the auxiliary energy source will deliver power. PCMM detects the DC bus voltage and calculates the reference current based on the power required by the auxiliary energy. The PCMM runs in buck mode when the auxiliary energy source is required for energy recovery.

TABULATION.1

Switching operation			Gate pulse				Operation modes
K1	K2	K3	Q1	Q2	Q3	Q4	Charging EV(AC to DC) V2H(DC-AC) DC-DC BUCK DC-DC BOOST
OFF	OFF	ON	OFF				
ON	OFF	OFF	PWM pulse				
ON	OFF	OFF	PULSE	OFF	PULSE	OFF	
ON	OFF	OFF	OFF	PULSE	OFF	PULSE	

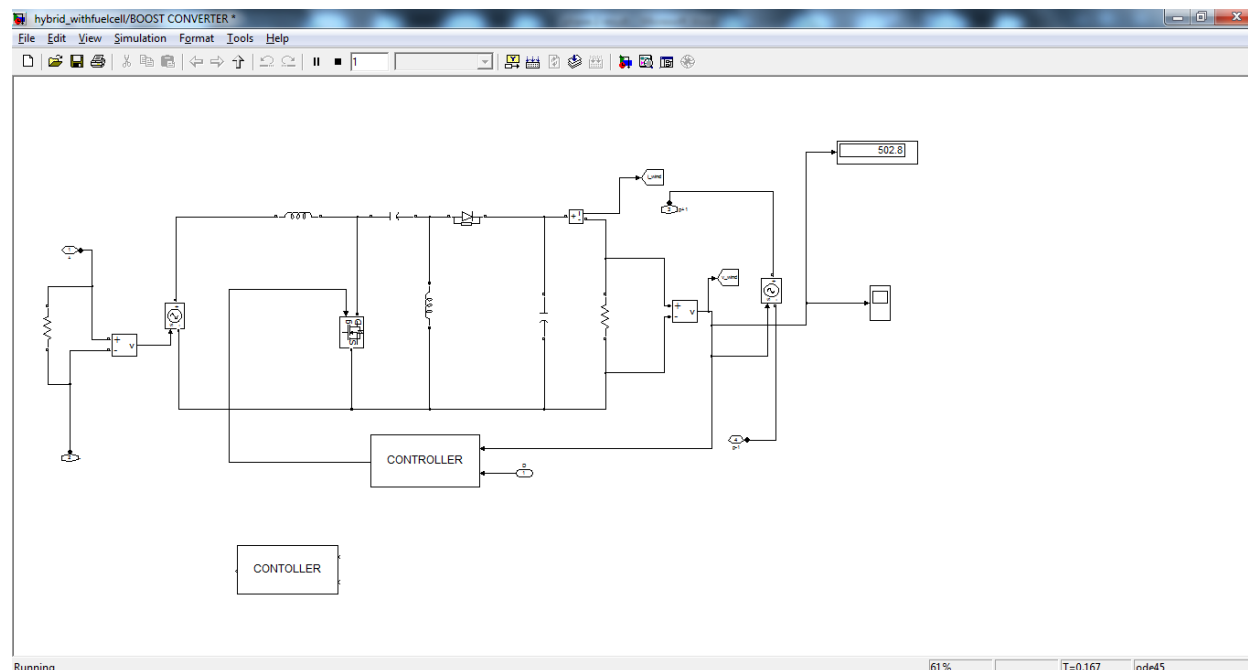

Figure 3: Flowchart of the function needed in EV with hybrid energy storage systems

**Bidirectional DC-DC Mode**

(MODE 1-BOOST OPERATION ,MODE 2- BUCK OPERATION)

The circuit diagram of MMPC for Bidirectional-DC – DC system operating in continuous conduction mode (CCM)

**Bi-DC/DC converter FIGURE.4**

The analogous circuit of the system in buck mode of the Bi-DC/DC converter is depicted in figure 4.

The state variable of the system is chosen to be the voltage of the capacitor  $v_c(t)$ , the current of the inductors  $i_{L1}(t)$ , and  $i_{L2}(t)$ . The input variable is  $v_i(t)$ , and the output variable is  $v_o(t)$ . The coefficient matrix of the average state space equation in the boost mode has dual symmetry, as does the coefficient matrix of the buck model. Two inner loops and one outside loop make up the controller.  $V_{ref}$  is the low voltage side's reference

In buck mode,  $V_{out}$  is the output voltage,  $dx1$  is the duty cycle of Q1, and  $dx2$  is the duty cycle of Q2.

$V_{ref}$  is the high voltage side's reference voltage,  $V_{out}$  is the output voltage,  $dx1$  is the duty cycle of Q3, and  $dx2$  is the duty cycle of Q4. In boost mode,  $V_{ref}$  is the high voltage side's reference voltage,  $V_{out}$  is the output voltage,  $dx1$  is the duty cycle of Q3, and  $dx2$  is the duty cycle of Q4. The system's PI regulators include  $PIx1$ ,  $PIx2$ , and  $PIx3$ . The "sisotool" toolbox of MATLAB can quickly extract the parameters of the PI regulators in buck and boost mode based on the model of the system shown.

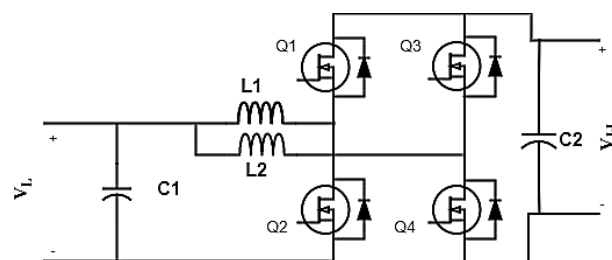
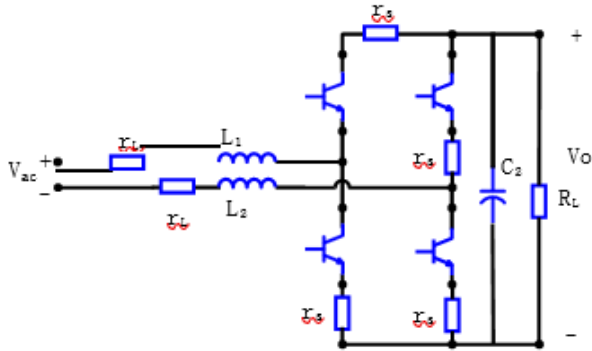

Figure 5 control structure of Bi-DC/DC

Figure 5 shows a closed loop control circuit for a BI DC-DC. Assume that the four power switches have the same settings. The negative half cycle and positive half cycle of the sine wave have the same corresponding circuits. As a result, just the positive half cycle must be examined. The state variables of the system are the voltage of the capacitor  $C_2$   $v_c(t)$ , the current of the inductor  $iL_1(t)$ , and  $iL_2(t)$ . The high side voltage  $v_o(t)$  is chosen as the output variable, while the AC side voltage  $v_{ac}(t)$  is chosen as the input variable. The output and the system's state space equation.



**MODE:3 AC-DC RECTIFIER MODE**

**FIGURE 6 AC-DC mode**

The simulation investigations were carried out in AC/DC mode, as shown in figure 6, for input voltages of 180 V and 240 V, respectively. At steady state, the output voltage is DC 400 V, the load resistance is 60 ohms, and the output power is 2.667 kW. The PCMM rectified the AC power supply and achieved power factor correction in this mode. Assume that the four power switches have the same settings. The negative half cycle and positive half cycle of the sine wave have the same corresponding circuits. As a result, just the positive half cycle must be examined. The state variables of the system are the voltage of the capacitor  $C_2$   $v_c(t)$ , the current of the inductor  $iL_1(t)$ , and  $iL_2(t)$ . The high side voltage  $v_o(t)$  is chosen as the output variable, while the AC side voltage  $v_{ac}(t)$  is chosen as the input variable. The output and the system's state space equation

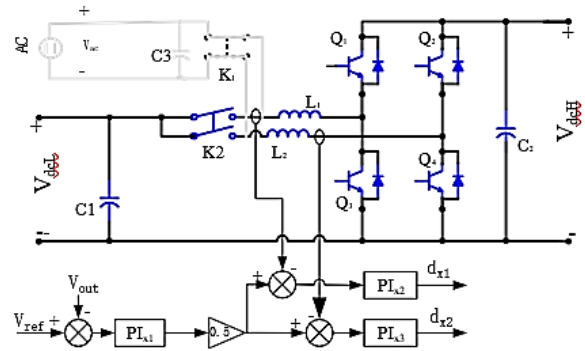
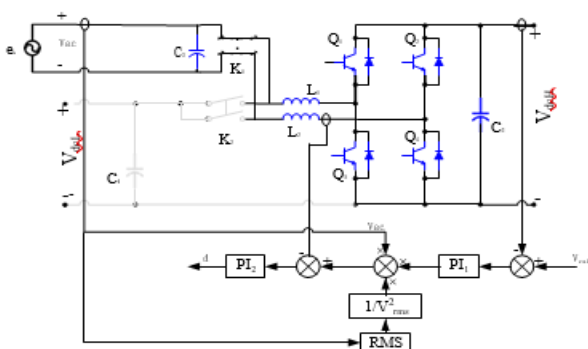

**Figure 7.controller mode of AC-DCMode**

An inner current loop and an outer loop make up the loop. The output current is proportional to the input voltage after the output of the regulator PI1 in the outer loop is multiplied by the input voltage  $v_{ac}$ . The RMS value of the input voltage is added as the feed forward to keep the output power constant when the input voltage is disturbed. The current loop's reference is the signal calculated by the multiplier, and the current loop is changed by regulator PI2 to obtain the PWM's duty cycle.

**MODE:4 DC-ACmode:VehicletoHome(V2H)**

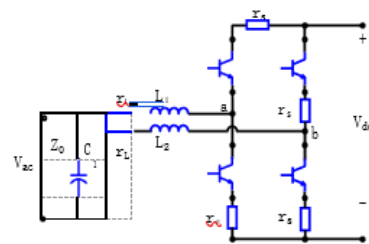

**Figure8.TheequivalentcircuitinDC/ACmode**

The output AC voltage and current phase do not need to track the grid voltage phase in an independent inverter mode. The output voltage is controlled by a voltage controller. For a DC voltage of 400 V and an RMS output voltage of 220 V

The wave form of the output voltage, input current, and DC side voltage in DC/AC mode, depicted in figure 8, with an input voltage of DC 350 V, output voltage of RMS 220 V, load resistance of 54, and frequency of 50 Hz. The DC high side voltage is represented by the pink curve, the output voltage by the blue curve, and the output current by



the yellow curve.

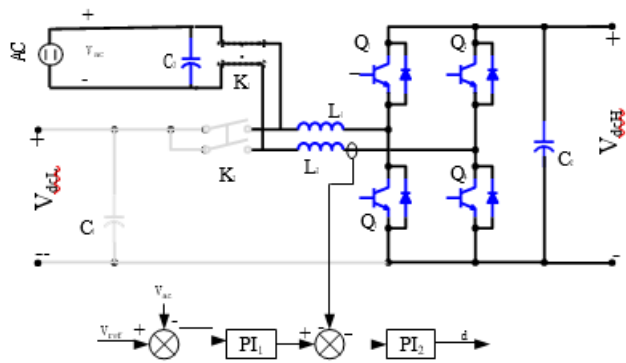

Figure 9: DC/ACmode.

A controller is used to control the output voltage in a close loop inverter. As a result, there's no need to employ a controller. In the case of a closed loop inverter, though, we'll need a controller that can keep the output voltage at the same level as our reference voltage. Measure the inverter's output voltage ( $V_{act}$ ). When  $V_{act}$  is compared to a reference voltage ( $V_{ref}$ ), the difference between the output voltage and the reference voltage is referred to as an error, and the controller is informed of this mistake (PI, PID).

**TLBO**

The TLBO algorithm is based on the effect of a teacher's influence on the output of learners in a class and is inspired by the teaching-learning process. The algorithm explains two primary ways of learning: I learning from a teacher (known as the teacher phase) and (ii) learning from other students (known as the student phase) (known as learner phase). A population of learners is considered in this optimization technique, and different subjects supplied to the learners are considered different design variables of the optimization problem, and a learner's result is equivalent to the optimization problem's 'fitness' value. The instructor is thought to be the finest answer for the entire population. The design variables are the parameters that go into the objective function of an optimization problem, and the optimum solution is the objective function's best value.

The teaching-learning-based optimization (TLBO) algorithm is a population-based algorithm that simulates the classroom teaching-learning process. This approach does not require any algorithm-specific control parameters and just requires common control parameters like population size and generation number.

**SIMULATION OF MULTI-MODE CONVERTER**

The simulations were conducted with input voltages of 180 V and 240 V, respectively. The input voltage and current are calculated for a DC 400 V output voltage, a load resistance of 60 ohms, and a steady-state output power of 2.667 kW. The PCMM rectified the AC power supply and achieved power factor correction in this mode.

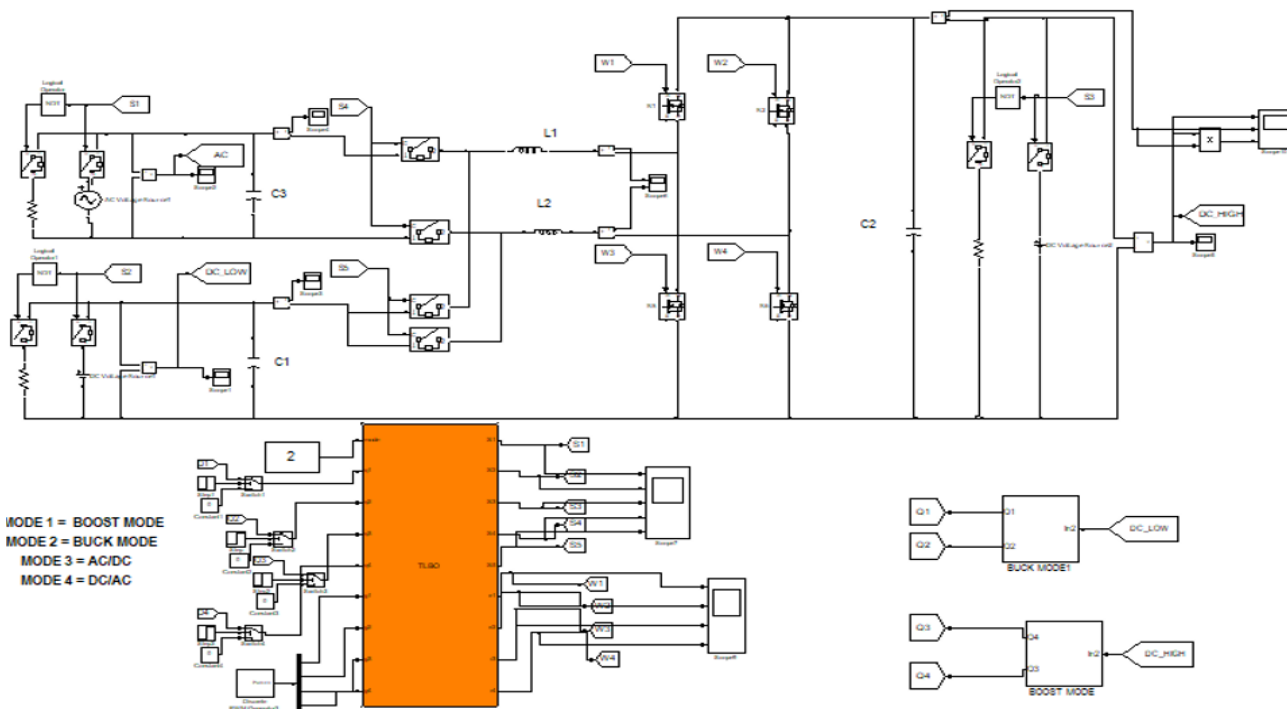

Figure 10 Simulation of TLBO based converter model

The PCMM must achieve DC conversion between the super capacitor bank and the lithium-ion battery pack, conversion from single-phase AC to the lithium-ion battery pack, and conversion from the lithium-ion battery pack to single-phase AC, according to the design requirements of a specific vehicle model. Capacitance and inductance must be matched with PCMM in order to meet the criteria of current ripple and voltage ripple in various modes. The inductance of L1 and L2 is 690  $\mu$ H, the AC filter capacitor C3 is 3 F, the high side filter capacitor C2 is 9400 F, and the low side capacitor C1 is 2200 F, according to the parameter matching results. For simulation and the primary circuit of the simulation model, Matlab/Simulink was utilised. For an input voltage of 220 V, an output voltage of 350 V, and a load power of 30 kW in boost mode, the output voltage.

The output voltage response procedure in buck mode with input voltage of 350 V, output voltage of 220 V, and load power of 30 kW. In boost mode and buck mode, the output voltage achieved a steady state in 100 ms and 80 ms, respectively. The output voltage error is less than one percent. The controller created using the presented model is precise. Tabulation 2 shows the parameter values.

Simulation investigations were conducted in AC/DC mode for input voltages of 180 V and 240 V, respectively. The input voltage and current are for a steady-state output voltage of DC 400 V, a load resistance of 60 ohms, and an output power of 2.667 kW. The PCMM rectified the AC power supply and achieved power factor correction in this mode.

The input voltage RMS value of 180 V is represented by Vac1, while the input current is represented by Iac1. The input voltage RMS value of 240 V is represented by Vac2, while the input current is represented by Iac2. Iac rec, on the other hand, represents the input current without power factor correction. The input current fluctuates proportionally with the input voltage with power factor adjustment, and the circuit has a resistive load characteristic. There is a power factor of more than 0.996.

The output AC voltage and current phase do not need to track the grid voltage phase in an independent inverter mode. The output voltage is controlled by a voltage controller. The output voltage and current are indicated for a DC voltage of 400 V and an output voltage RMS value of 220 V. Figure 14 shows the voltage Vac1, Vac2, and Vac3 for RMS 220 V output voltage with loads of 500 W, 3 kW, and 1.5 kW. The current waveforms for 500 W, 3 kW, and 1.5 kW operations are Iac1, Iac2, and Iac3. The frequency spectrum of the output current is studied, and each order harmonic is calculated.

## SIMULATION OUTPUT

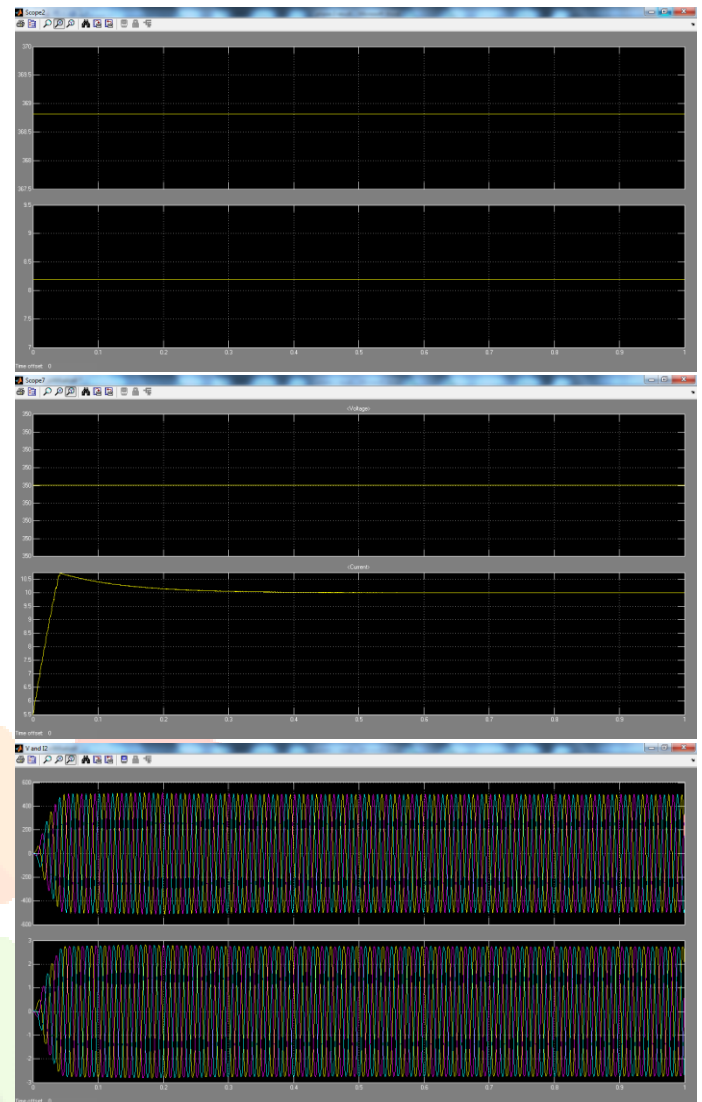

**FIGURE 11:** BUCKT OUTPUT **FIGURE 12:** BOOST OUTPUT

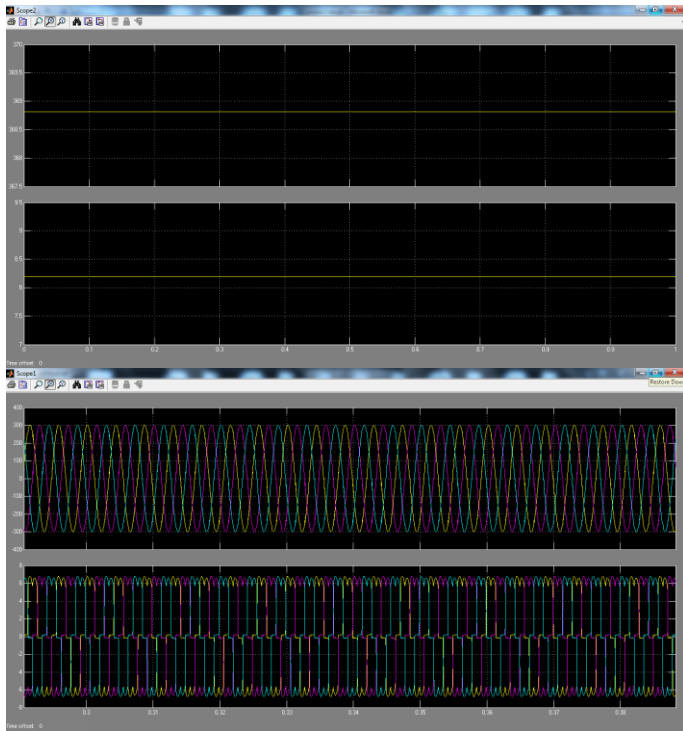

**FIGURE 13: DC TO AC MODE, FIGURE 14: AC TO DC MODE**

## CONCLUSION

The topology of a power converter for multifunctional operation in an EV has been built and investigated utilising the TLBO algorithm in PCMM IS. Because the PCMM used an interleaved converter construction, the voltage and current ripples were found to be lower than with traditional converters. As a result, the total inductor current ripple is calculated. Is inductor current required for both buck and boost operation. The system's power factor for AC – DC and DC – AC operation has also been increased. For easier modelling and analysis, the system uses loads that are equivalent to batteries. Information from the Battery Management System (BMS) can also be considered when working with an actual Electric Vehicle model. This could be the project's future scope, coupled with the PCMM's hardware implementation.

## REFERENCES

- [1] RaseelulMahboob ,PNithin,S VijithK “multimode power converterfor electric vehicle charging oftheFifthInternationalConferenceonCommunication andElectronicsSystems(ICCES2020)IEEEConference,IEEEExploreISBN:978-1-7281-5371-1,2020
- [2] G.Aswani, V.S.Bhadoria,andJ.Singh, “ ElectricVehicles inIndia: Opportunities and Challenges,”2018 *Int. Conf. Autom. Comput. Eng. ICACE2018*,pp.65–71,2018.
- [3] M. Giri and T. B. Isha, “Comparison of non-isolated schemes forEVchargingandtheireffectonpowerquality,”in2017InternationalConferenceonCircuit,PowerandCo

mputingTechnologies(ICCPCT),2017,pp.1–7.

- [4] T.KimandS.Kwak,“AFlexibleVoltageBus Converterforthe48-/12-V Dual Supply System in Electrified Vehicles,” *IEEE Trans. Veh. Technol.*,vol.66,no.3,pp.2010–2018,2017
- [5] S. Dusmez and A. Khaligh, “A charge-nonlinear-carrier-controlledreduced-part single-stage integrated power electronics interface forautomotive applications,” *IEEE Trans. Veh. Technol.*, vol. 63, no. 3,pp.1091–1103,2014.
- [6] S.S.Indalkar and A.Sabnis, “ Comparison ofAC-DC Converter Topologies Used for Battery Charging in Electric Vehicle,” in *20192ndInternationalConferenceonIntelligent Computing,Instrumentation and Control Technologies (ICICICT)*, 2019, vol. 1,pp.1624–1627.
- [7] PritishKulshreshtha, Sanjay Gairola, and Anurag Verma, “Power FactorCorrectionbyInterleavedBoostConverterUsingPIController,”*Ijicrt*,vol.1,no.5,pp.481–485,2016.
- [8] W. Feng and L. Yutao, “Modelling of a power converter withmultiple operating modes,” *World Eletri. Veh. J.*, vol. 9, no. 1,2018.
- [9] H.S.Song,I.P.Yoo,K.Y.Jang,S.Shin,andJ.H.Joo,“Systemfor recharging plug-in hybrid vehicle and control method for thesame,”vol.2,no.12,2010.
- [10] K.K.KhanandA.Vijayakumari,“ A dualmodecontrolforbridgelessSEPICpowerfactorcorrectionrectifier,”in2016InternationalConferenceonEmergingTechnologicalTrends(ICETT),2016,pp.1–6.
- [11] S.M.R.Tousiet *al.*, “ A digital powerfactorcorrection(PFC)control strategy optimized for DSP,” *IEEE Trans. Power Electron.*,vol.2,no.6,pp.15–22,2013.
- [12] T.Nussbaumer,K.Raggl,andJ.W.Kolar,“Designguidelinesforinterleaved single-phase boost PFC circuits,” *IEEE Trans. Ind.Electron.*,vol.56,no.7,pp.2559–2573,2009.
- [13] D. P. T uttle, R. L. Fares, R. Baldick, and M. E. Webber, “Plug-InVehicle to Home (V2H) duration and power output capability,”2013 *IEEE Transp. Electrifi. Conf. Expo Components, Syst. PowerElectron. - From Technol. to Bus. Public Policy, ITEC 2013*, no.June,2013.
- [14] S. Power and A. Supplies, *Libro - Sanjaya Maniktala - SwitchingPowerSupplies.pdf.*. Powerand A. Note, “ IEC / EN61000 Standards for PowerSupplies,”2018
- [15] R.V. Rao, V.J. Savsani, D.P. Vakharia, Teaching–learning-based optimization: a novel method for constrained mechanical design optimization problems, *Com-put. Aided Des.* 43 (March (3)) (2011) 303–315, ISSN 0010-4485.
- [16] T. Niknam, R.A. Abarghoee, M.R. Narimani, A new multi objective optimiza-tion approach based on TLBO for location of automatic voltage regulators

indistribution systems, Eng. Appl. Artif. Intell. 25 (2012) 1577–1580.

- [17] MuraliMuniraj & R. Arulmozhiyal, “Investigation on Block Chain Based Controller Design for Bidirectional Inverter for Micro Grid Tie System”, Journal of Computational and Theoretical Nanoscience, Vol. 16, 1552–1559, APR-2019.
- [18] R Arulmozhiyal, P Thirumalini, M Murali, Implementation of Multilevel Z-Source Inverter using Solar Photovoltaic Energy system for Hybrid Electric Vehicles, - Computation and Communication Technologies, 2016.

