



INTERNATIONAL JOURNAL OF CREATIVE RESEARCH THOUGHTS (IJCRT)

An International Open Access, Peer-reviewed, Refereed Journal

SMART CROP PROTECTION & AUTOMATIC IRRIGATION SYSTEM USING IOT & ML

Maheswari D¹, Harish R², Sowmiya S³, Kokila Aiswarya M⁴

¹ Faculty, Department of Electronics and Communication Engineering

^{2,3,4} Students, Department of Electronics and Communication Engineering
Agni College of Technology, Chennai, India.

Abstract: This document provides a guide for yield monitoring arrangements for farm safety against animal and bird attacks and climate change conditions. Agriculture-related issues have historically impeded the nation's progress. Water should be managed well, and system circuit complexity should be minimized. Here, we used various sorts of controllers in addition to a positioner on behalf of WSN and Arduino Microcontroller. IoT devices stay adept around the farming ground, which will be warehoused onboard as well as in the IoT cloud. And instantaneously a message will be generated automatically towards the recorded quantity using a GSM module to inform about the intrusion. The system will elevate a buzzer if the intrusion is found after processing the available information. The result will be generated based on the database of the farmer's mobile to take the necessary action.

Key Words—Arduino UNO, Sensor, Camera, Buzzer, IOT, Smart Irrigation, Protection.

I. INTRODUCTION

The population's dietary needs are met by agriculture, which also produces a variety of industrial raw materials. Animal disturbance in agricultural areas results in a significant loss of crops. One of the main risks to decreasing crop productivity is crop damage brought on by animal assaults. Crop raiding is one of the conflicts that is enraging human-animal relationships the most because of the extension of cultivated land into former wildlife habitats. In comparison, elephants and other animals come into contact with humans in various ways, such as by ravaging harvests, damaging food stores, water reserves, houses, and other resources, harming therefore, the extinction of humanity. Ranchers in India face real dangers from disturbances, common disasters & destruction by creatures that result in lower yields. Since human and creature well-being is equally indispensable. Therefore, in homestead areas, the structure of an animal's position is vital. The farmer who gives water to crops at precise times and amounts should benefit from this approach. The water system arrangement provides lodging thus protecting the venture of the scene. This structure keeps the lawn and scene balanced and delightful. It also aims to decrease the calculation of wastewater collection. Crop loss from animal disturbance is significant in agricultural areas. The automation irrigation system keeps track of temperature changes and moisture sensors around the crop area to determine the exact time to switch on and off the motor. The most important goal of this task is to grant an awesome solution to this trouble, as a result with the purpose of the economic losses incurred through the support of our farmers are minimized to get a truthful crop.

II. PROBLEM STATEMENT

The designed system, which is based on an Arduino Uno, will instantly find the intrusion. The results of the level of intrusion detection are taken into consideration. These results about the intrusion are being carried out through various sensors for crop protection and safeguarding of agricultural lands. For instance, in any area where there is a lack of security in the farmlands, the system can be installed and used according to the requirements.

III. EXISTING SYSTEM

Protecting crops from animals and birds is a crucial aspect of intelligent crop protection systems. Following are some examples of clever crop security tools that help reduce animal and bird damage:

1. Smart Sensors: To identify the presence of birds and animals, smart sensors can be installed in the fields. Real-time analysis of the sensor data can be used to determine the species of animal and how it behaves.
2. Devices to Keep Animals and Birds Away from Crops: Mammals are repulsed by the high-frequency sounds that ultrasonic devices emit, although birds can be scared away by visual devices like moving flags or balloons.
3. Netting: To detect animals and birds, crops might be covered in netting. The netting is often made of sturdy materials that can endure bad weather and the weight of animals
4. Chemical Repellents: Some farmers use chemical repellents to stop birds and other animals from devouring their crops. These repellents, which are sprayed over the crops, frequently contain ingredients that are undesirable to birds and animals.

5. Animals can be effectively kept out of crops using electric fences. They work by providing a mild electric shock to any animals that come into contact with them.
6. Motion-Activated Sprinklers: These devices have motion sensors that activate a sprinkler system when an animal comes too close to crops. The sudden rush of water generally scares animals away.

IV. PROPOSED SYSTEM

In the proposed system Arduino, camera, soil moisture sensor, Relay, GSM, buzzer, and monitor are used. This field of this effort remains towards withdrawing to monitor the system for crop security conflicting with subconscious occurrences and meteorological conditions. When the moisture content is below a critical level which is determined by the sensor planted in the fields, as the system is automated the water pumps are switched on. This ensures the complete safety of crops from animals also as from the weather conditions thus preventing the farmer's loss. Automatic humans avoid human errors and check soil moisture level

4.1 Arduino

Arduino is a tool for building computers that are more capable than a desktop computer of sensing and controlling the physical world. It consists of a development environment for building software for the board's basic microcontroller and is an open-source physical computing platform. Using switches or sensors as inputs and a range of lights, motors, and other physical outputs as controls, Arduino can be used to create interactive things. Arduino projects can communicate with software running on your computer or work independently. The open-source IDE is available for free download, and the boards can be manually put together or purchased already put together. It has a sixteen MHz crystal oscillator, 20 virtual input/output pins, 6 analog inputs, a USB port, a enanrgy jack, and different features.

4.2 Soil moisture sensor

A tool that gauges the moisture or water content of the soil is called a soil moisture sensor. It is frequently used to improve irrigation and water management techniques in horticulture, agriculture, and landscaping. Farmers and gardeners may optimize their watering schedules and avoid overwatering, which can result in plant stress and disease, with the aid of soil moisture monitors. Using less water for irrigation can also contribute to water resource conservation.

4.3 GSM module

An animal smart crop protection system may include a GSM (Global System for Mobile Telecommunication) module. When the system detects animals entering the protected agricultural area, the GSM module can be configured to send SMS notifications to the farmer's phone or the phone of the animal caretaker. This may enable prompt reaction and intervention to stop crop harm. The smart crop protection system can also be remotely controlled via the GSM module. The GSM module can be used to gather information on agricultural damage and animal behavior. The smart crop protection system's efficacy can be improved over time using this data.

4.4 Web camera

The purpose of a webcam is to record or broadcast video to a computer or computer network. They are mainly employed in video telephony, social networking, live streaming, and security. Webcams are typically connected to a device through USB or wireless protocols. They may be integrated laptop hardware or peripheral devices

4.5 Software Explanation

This software appears to be an implementation of a graphical user interface (GUI) for a system related to agriculture field protection using MATLAB. The GUI has several push buttons and axes to display the results.. The main functionality of the system appears to be related to image processing and machine learning. Push button 1 initializes a camera and takes a snapshot. The push button 3 converts the snapshot image to grayscale, enhances the contrast of the image, and displays the result. Push button 4 segments the image, and push button 5 classifies the segmented image using machine learning techniques. Finally, push button 6 clears the axes and title. The software is a MATLAB GUI application for agriculture field protection. The GUI has six pushbuttons and two edit boxes The first pushbutton, labeled "Pushbutton1," starts the webcam preview and captures an image from the camera. It then displays the image on the first axes of the GUI and saves it as "1.jpg" in the current folder. The second pushbutton, labeled "Pushbutton3," converts the captured image to grayscale and enhances its contrast. The resulting image is displayed on the second axes of the GUI. The third pushbutton, labeled "Pushbutton4," segments the grayscale image using the "region_seg" function and displays the segmented image on the fourth axes of the GUI. The fourth pushbutton, labeled "Pushbutton5," classifies the segmented image into three categories (unhealthy, healthy, or background) using a neural network, and displays the classified image on the third axes of the GUI. The fifth pushbutton, labeled "Pushbutton6," calculates the percentage of unhealthy plants in the segmented image using the "predict" function and displays the result in the first edit box of the GUI. The sixth pushbutton, labeled "Pushbutton2," clears the GUI by deleting all images from the axes and resetting the edit boxes.

4.6 Algorithm Explanation

A technique for segmenting images is the Chan-Vese algorithm. It is a different method of segmenting images that isolates the object of interest from the backdrop by modeling it as an area in the image. An energy function that is specified over the image domain is the object of the algorithm. Two components make up the energy function: an internal energy term that supports smoothness within the segmented region and an exterior energy term that motivates the region to follow the borders of the object. The segmented region's overall variation, which gauges the degree of fluctuation in intensity values within the region, serves as the foundation for the internal energy term. This phrase rewards areas with consistent intensity ratings and denigrates areas with significant variance.

The difference between the picture intensity values inside and outside the region serves as the foundation for the external energy term. By reducing the gap between the inside and outside values, this phrase promotes the area to follow the object boundaries. By resolving a partial differential equation (PDE) that moves the region bounds in the direction of the object boundaries, the Chan-Vese algorithm iteratively minimizes the energy function. Numerical techniques, such as level set or region-based methods, are used to solve the PDE. The Chan-Vese technique is frequently employed in a variety of computer vision applications, including object tracking, medical picture analysis, and image segmentation.

V. WORKING AND METHODOLOGY

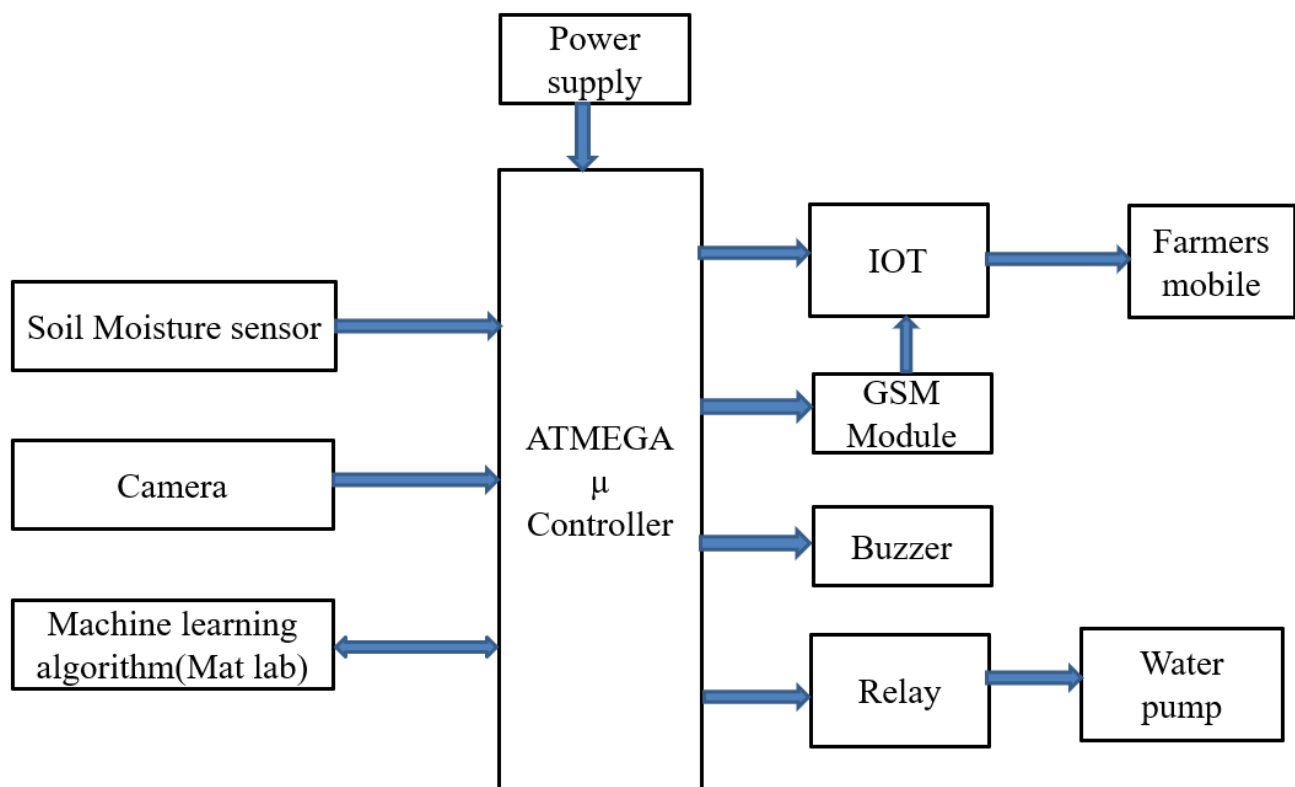

FIG.5: BLOCK DIAGRAM

The suggested system's block diagram is displayed in fig.5 The hardware parts are linked together as illustrated in the figure. The system must be initialized during operation, and the hardware connections must be examined. Ensure that every connection is made. We are employing a soil moisture sensor in this project. Also, historical information on the amount of irrigation utilized in prior periods is taken into account to alter the amount of water required for irrigation in order to create a more accurate system. One of the system's key components is the Arduino Uno. A microcontroller with an 8-bit RISC architecture with attributes like high performance and low power is called the Arduino Uno, sometimes known as the ATmega 328p. The Arduino is equipped with a camera, and soil moisture sensor which, when combined, allows it to detect intrusions. Once the sensor has been accustomed to its environment, it will be activated by any change in the intensity of infrared radiation. If an intrusion is found, the animal or bird that was introduced into the field is determined by analysis using the Matlab software under image processing. The notification about the intrusion and how to take the necessary action is sent to the crop owner using a GSM module. A linked soil moisture sensor is seen here. Additionally, historical information on the amount of irrigation utilized in prior periods is taken into account. The system's webcam is equipped with qualities including high sensitivity for use in low light, low voltage, and reliable color images. If an intrusion is found, it is examined using the Mat lab software's image processing to determine which animal it is.

VI.FLOW CHART

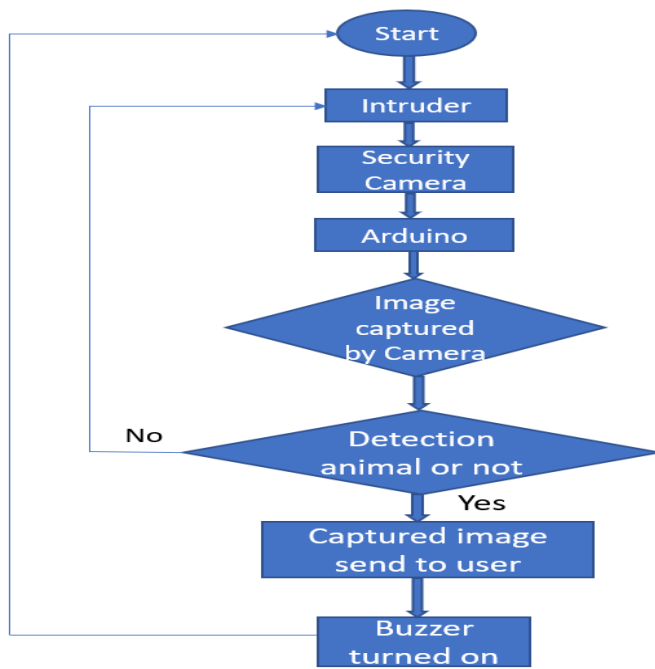

Fig.6: Flow Chart of Proposed System

VII.RESULT

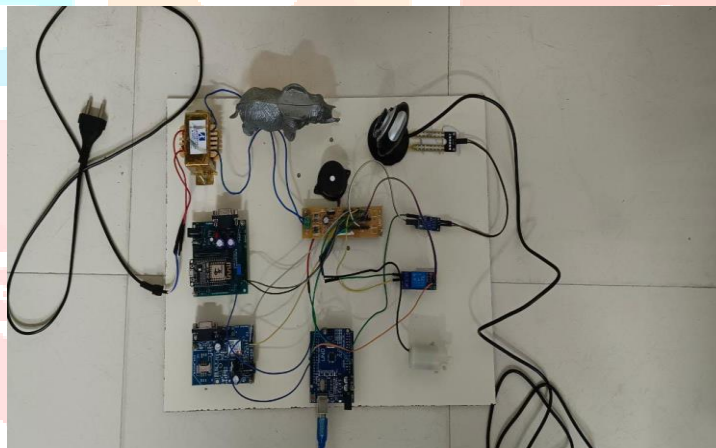

Fig.7: Hardware Prototype

```
COM6
Moist level :1012.00
Moist level :1012.00
Moist level :1011.00
Moist level :1012.00
Moist level :1012.00
Moist level :1012.00
Moist level :1012.00
Moist level :1012.00
Moist level :1012.00
Moist level :1012.00
Moist level :1012.00
ELEPHANT DETECTION
message sent

pinMode (7, OUTPUT);
pinMode (8, OUTPUT);

}

void loop() {
digitalWrite (7,LOW);

digitalWrite (8,LOW);

while (Serial.available ())
{
i=Serial.read ();

if (i=='a')
{
digitalWrite (8,HIGH);
Serial.println ("HEN DETECTION");
}
}

Sketch uses 6930 bytes (21%) of program storage space. Maximum is 32256 bytes.
Global variables use 452 bytes (22%) of dynamic memory, leaving 1596 bytes for local variables. Maximum is 2048 bytes.
```

Fig.7: Result of the Hardware Prototype

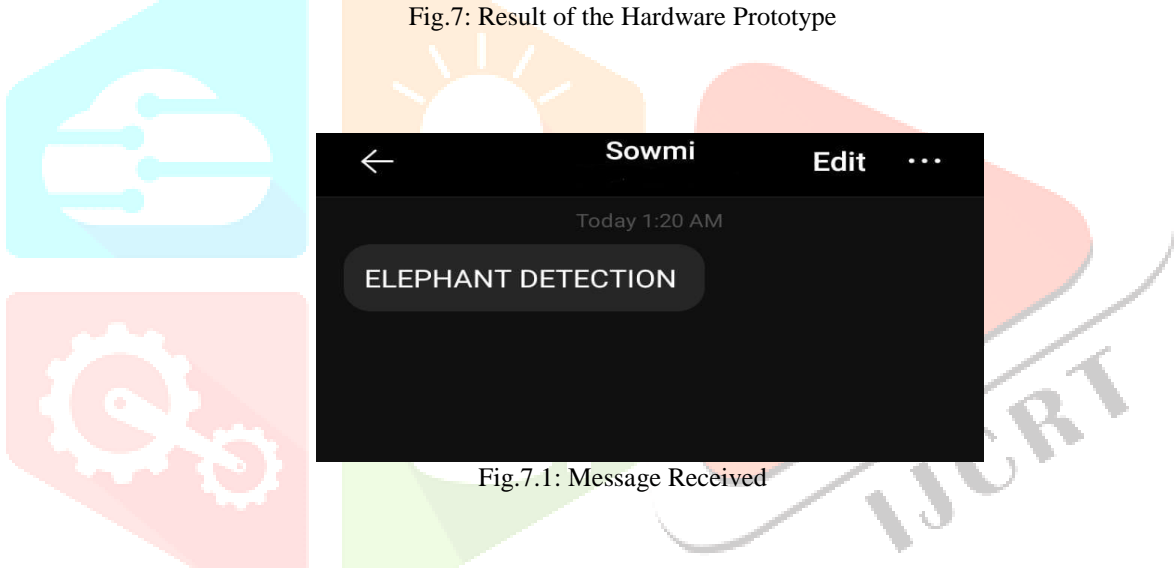

Fig.7.1: Message Received

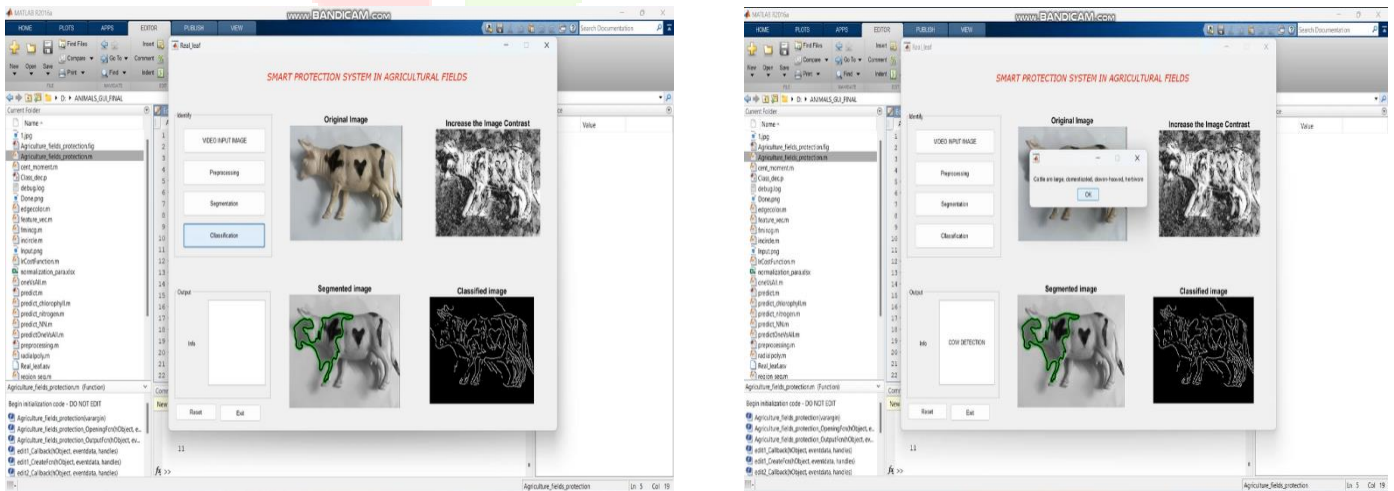

Fig.7.2: Output of the Software

VIII. CONCLUSION

The "Internet of Things" is widely used to connect gadgets and collect data. This approach for monitoring agriculture is a dependable and effective system, as well as corrective action. Wireless field monitoring eliminates the need for human labor and enables users to accurately track changes in agricultural productivity. It costs less money and uses less energy. The system for smart agriculture has been created and assembled. The new technique is more effective and advantageous for farmers. It provides information about the air's temperature and humidity in agricultural fields if they deviate from their ideal range. The technology can be applied to greenhouses and plants that require specific temperatures. The use of such a technique in the field can undoubtedly aid with advancement.

IX.FUTURE SCOPE

While there is a growing need for sustainable agriculture practices to fulfill the rising demand for food with constrained resources like land, water, and labor, the future potential of smart crop protection and irrigation is quite promising. The cost and accessibility of intelligent crop protection and irrigation systems will decrease, enabling their widespread adoption by farmers of all sizes. These systems will also develop in sophistication, using more data points and more powerful algorithms to generate predictions and judgments that are more correct. Also, as sustainable agriculture receives greater attention, government funding and support for research and development in this subject is anticipated to increase, spurring even more progress in the industry. In general, intelligent crop protection and irrigation technologies have the ability to completely transform how we live

X.REFERENCES

- [1] Ispeeta Nanda, Suman Maloji, Chadalavada Sahithi,medepalli swath, Vinod Kumar Shukla IIOT Based SMART CROP PROTECTION AND IRRIGATION SYSTEM 2020 Seventh International Conference on Information Technology Trends (ITT) | 978-1-7281-8379-4/20/\$31.00 ©2020 IEEE
- [2] Srushti Yadahalli, Aditi Parmar, Prof.Amol Deshpande, Smart Intrusion Detection system for crop Protection by using Arduino, Proceedings of the Second International Conference on Inventive Research in Computing Applications (ICIRCA-2020)IEEE Xplore Part Number: CFP20N67-ART; ISBN: 978-1-7281-5374-2
- [3] Thirunavukkarasu R R, Meeradevi T, Manoj Kumar P, Smart irrigation and crop Protection using Arduino,2021 7th International Conference on Advanced Computing and Communication Systems (ICACCS) | 978-1-6654-0521-8/20/\$31.00 ©2021 IEEE
- [4] 2017 International Conference on Recent Advances in Electronics and Communication Technology 978-1-5090-6701-5/17 \$31.00 © 2017 IEEE
- [5] R.Nageswara Rao, B. Sridhar, IOT Based Smart Crop Field Monitoring and Automation Irrigation System, Proceedings of the Second International Conference on Inventive systems and control (ICISC 2018).
- [6] International Journal of Engineering and Advanced Technology "C. Asha Beaula" Assistant Professor at National Engineering College, Kovilpatti (IJEAT), Smart Crop Protection System from Animas, ISSN: 2249 – 8958 (Online), Volume-9 Issue-4.
- [7] S.P.Jolhe, Smart Crop Protection System, International Journal of Latest Engineering Science (IJLES), Volume 4,issue-04, E-ISSN:2581-6659.
- [8] Dr.K.Senathipathi, Dr.A.Shobana Assistant Professor, Sri Krishna College of Engineering and Technology, Coimbatore, India.Animal Detection using Image Processing for Agri, International Journal of Disaster Recovery and Business Continuity Vol.11, No. 1, (2020), pp. 3381–3387
- [9] Mr. Jayesh redji, Dr. Sharada Chougule, Smart Crop Protection System From Animals, International Journal of Creative Research Thoughts (IJCRT), ©2022 IJCRT, volume 10, issue 4 April 2022| ISSN: 2320-2882
- [10] Vikhram. b; Revathi. b: animal detection systemin farm areas, international journal of advanced research in computer and communication engineering, volume 6, issue 3, ISO 3297:2007, march 2017.
- [11] Vikas pavane; arti Raut, protection from wild animals using intelligent surveillance system, international journal of research in advent technology, ISSN:2321-9637, April 2018.
- [12] P.Munaswamy, Smart agriculture system using IoT technology, international journal of recent technology and engineering,ISSN:2277-3878,volume 7,issue-5,Jan 2019
- [13] Eka Maulana.. Animal presence detection for elephants and extruding method based on bee frequency, IEEE,2018.
- [14] Madhu. b, smart agriculture: a bliss to farmers, international journal of engineering sciences and research

technology, ISSN:2277-9655, APRIL,2017.

[15] Arnaud S.R.M. Ahouandjinou, Probus M.A.F.Kiki, Kokou Assogba, Smart Environment Monitoring System by Using Sensors Ultrasonic Detection of Farm Pests, 978-1-5386-0706-0\17\31.00 ©2020 IEEE.

