

SINGLE SWITCH ENHANCED GAIN MODIFIED SEPIC CONVERTER

Ms. Aleesha P Ebrahim, PG Scholar
Dept of Electrical & Electronics Engg,
Mar Athanasius College of Engineering
Kothamangalam, Kerala, India

Dr.Siny Paul
Dept of Electrical & Electronics Engg,
Mar Athanasius College of Engineering
Kothamangalam, Kerala, India

Prof. Beena M Varghese
Dept of Electrical & Electronics Engg,
Mar Athanasius College of Engineering
Kothamangalam, Kerala, India

Prof. Reenu George
Dept of Electrical & Electronics Engg,
Mar Athanasius College of Engineering
Kothamangalam, Kerala, India

Prof. Neema S
Dept of Electrical & Electronics Engg,
Mar Athanasius College of Engineering
Kothamangalam, Kerala, India

Abstract—Recent years a modified SEPIC converter with intrinsic high static gain and reduced voltage stress is used in several applications such as renewable energy sources, high power factor rectifiers, LED drivers, battery chargers, and high conversion ratio bidirectional dc/dc converters. The reduction in converter losses and electromagnetic interference using a soft-switching technique is important for high power density applications. And the circuit consist of two switches. We can improve the gain and efficiency of the circuit by eliminating one switch. Reduction in switch may results in loss of soft switching property but that can be neglected as there is not much difference in stress and conduction losses. A simple circuit with one switch and voltage multiplier element can provide improved gain and efficiency for a SEPIC converter.

Index Terms—SEPIC Converter, Voltage Multiplier, Gain, Efficiency, Switched inductor

I. INTRODUCTION

Due to the increase in demand of high voltage gain dc/dc converters for various applications supplied by low dc output voltage power sources, the development of these converters has been a wide research area in the recent years. The high voltage gain dc/dc converters are used in numerous applications, such as low power wind turbines, photovoltaic (PV) systems, fuel cells (FC), dc distribution networks, energy storage systems, hybrid electric vehicles, and uninterruptable power supplies [4]. The output dc voltage of the renewable energy sources such as PVs and FCs is low. Therefore, high step-up dc/dc converters should be used to boost and regulate the voltage level in these systems. Also, in order to achieve maximum power point tracking for PV panels, the input current of the converter should be continuous with low ripple. In FCs, the output power regulation is important for their proper operation. Thus, the dc/dc converters with continuous input current are preferred. Moreover, the dynamic performance of the system will be improved by a dc/dc converter with continuous input current. Accordingly, in order to use a dc/dc converter in

renewable energy sources, it should have a high voltage transfer gain and continuous input current [5], [6]. Hence, the traditional buckboost converter is not suitable due to its discontinuous input current. Also, the switch voltage stress of the boost converter is equal to the output voltage. Thus, high output voltage requires the use of high voltage switches, which increases the conduction and switching losses.

A SEPIC is essentially a boost converter followed by an inverted buck-boost converter. It consist of two inductors, one at the input side and other connected to ground and connected together by a coupling capacitor. The modified SEPIC converter is a high performance dc/dc converter with intrinsic high static gain and reduced voltage stress in all semiconductors used in several applications as renewable energy sources, high power factor rectifiers, LED drivers, battery chargers, and high conversion ratio bidirectional dc/dc converters. However, most part of developments proposed using this topology is based on the hard-switching structure. The reduction in converter losses and electromagnetic interference using a soft-switching technique is important for high power density applications..

A classical SEPIC dc/dc converter is a step-up/stepdown dc/dc converter topology presents some drawbacks, such as limited static gain and high semiconductor voltage stress that is equal to the sum of the input and output voltages. Therefore, the performance of this topology can be limited in applications with high static gain due to high conduction and switching losses and extreme duty-cycle operation. However, with the inclusion of a diode and capacitor, a new structure is obtained, and many of these limitations are overcoming. The modified SEPIC converter shown in Fig. 1 was proposed in [1] and [2] and is a high static gain structure ($V_o/V_i > 5$) operating with reduced voltage stress in all semiconductors and presenting high efficiency. The maximum voltage in all

semiconductors is lower than the output voltage, reducing the converter losses. The converter input presents reduced current ripples operating in continuous conduction mode (CCM) and also in discontinuous conduction mode (DCM) due to the input inductor.

The basic structure of the modified SEPIC converter were used in HPF rectifiers, and structures using switching inductors also present all dissipative commutations and also present problems with the diodes reverse recovery current in the CCM operation. The resultant switching losses limit the switching frequency and the power density, in order to maintain a high efficiency operation. Some of these problems are reduced in topologies using coupled inductors due to the presence of the coupled inductors leakage inductance. The leakage inductance allows the switch turn-on with zero current switching (ZCS) even operating in CCM and also reduces the diodes reverse recovery current. Therefore, the use of some soft-switching techniques in these structures can result in a high density topology operating with high switching frequency, increasing the applications of this type of converter.

A single switched enhanced gain SEPIC converter provides improved gain and reduced switching losses. The circuit have only one switch, provides simple switching process. Reduced number of switches along with voltage multiplier cell [9] provides improved gain and enhanced efficiency. One of the switch in soft switching SEPIC converter circuit is replaced by diode. Also one more diode replaces an inductor, all together gives a better, efficient converter circuit.

II. METHODOLOGY

The Single switched enhanced gain SEPIC converter can be derived from the basic SEPIC converter by adding a Voltage multiplier cell to increase the output voltage and by eliminating one switch and a inductor. Thus by increasing the gain and efficiency of the converter. The circuit consist of one power switch S , one inductor L_1 , five capacitors $C_1, C_2, C_3, C_4,$ and C_5 , five diodes D_1, D_2, D_3, D_4, D_5 and load R .

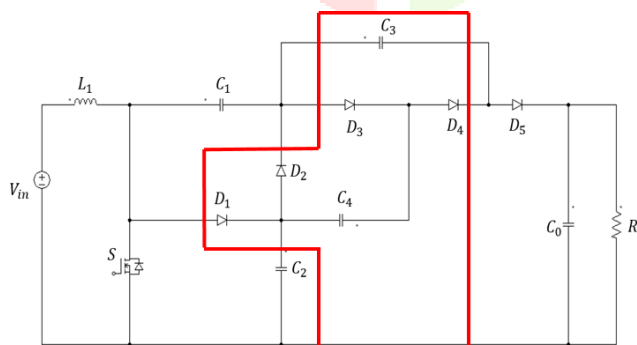

Fig. 1. Single switched enhanced gain SEPIC Converter

A. Modes of Operation

The proposed converter operates in continuous current mode of boost inductor. There are two modes of operation.

1) *Mode 1:* At $t = t_0$, the switch S is turned on and diodes D_2 and D_4 are on. At this moment, the input DC power V_{in} charges the inductors L_1 through power switch S . The capacitor C_1 and C_3 charges and capacitors $C_2, C_4,$ and C_0 discharges. Figure 2(a) shows the operating circuit of mode 1.

2) *Mode 2:* At $t = t_1$, the switch S is turned off and diode D_1, D_3 and D_5 are conducting. At this moment, inductor L_1 discharges and the capacitors C_2, C_4, C_2 charges. Figure 2(b) shows the operating circuit of mode 2.

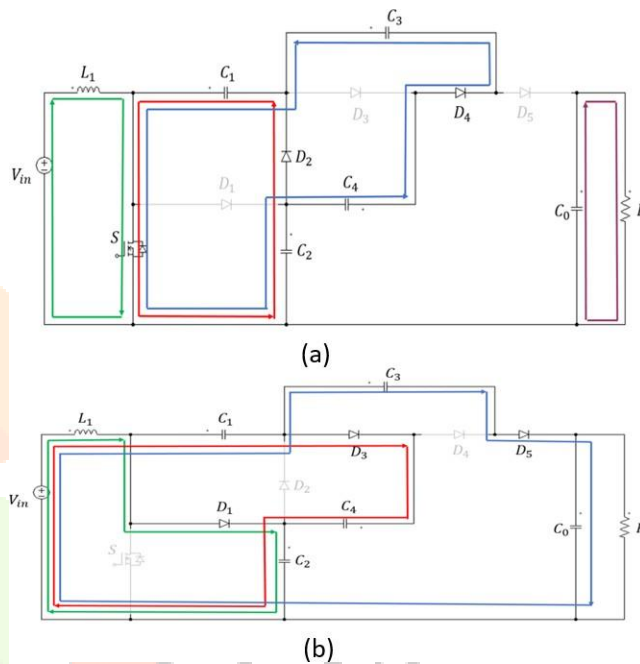

Fig. 2. Operating Modes. (a) Mode 1; (b) Mode 2

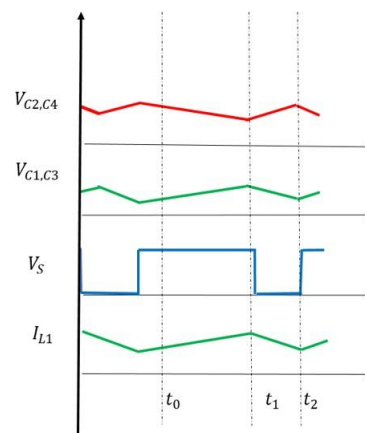

Fig. 3. Theoretical Waveforms of Single switched enhanced gain SEPIC Converter

B. Design of Components

In order to operate a converter properly, its components should be designed appropriately. Some assumptions are taken for the design of SEPIC boost converter. It consists of design of load resistance, inductors L_1 , and the capacitors C_1 , C_2 , C_3 , C_4 & C_0 . The input voltage is taken as 30V. The output power and output voltage are taken as 480W and 304.5V. Switching frequency is 70kHz. On solving (1) output current is obtained as 1.37A.

$$I_o = \frac{P_o}{V_o} \quad (1)$$

Duty Ratio can be found by (2) which is taken as 0.7391. The value of load resistor is set as 222Ω in (3).

$$\frac{V_o}{V_{in}} = \frac{2 + D}{1 - D} \quad (2)$$

$$R_o = \frac{V_o^2}{P_o} \quad (3)$$

The inductor L_1 is obtained by taking current ripple as 40% of I_{L1} .

$$L_1 \geq \frac{D * V_{in}}{f_s * \Delta i_{L1}} \quad (4)$$

The inductor L_1 is obtained by taking

$$I_{L1} = \frac{P_o}{V_{in}} \quad (5)$$

By substituting these values to (4) it is approximated $1000\mu\text{H}$ for L_1

$$L_1 \geq \frac{D * V_{in}}{f_s * \Delta i_{L1}} \quad (6)$$

The design of the capacitor mainly considers the voltage stress and maximum acceptable voltage ripple across it. The capacitors C_1 , C_2 , C_3 , C_4 & C_0 are obtained by taking voltage ripple as 1% of voltage across corresponding capacitors. By substituting values to (7), (8) & (8) capacitor values are approximated to $4.7\mu\text{F}$ for C_1 and C_2 , C_3 and C_3 are $50\mu\text{F}$ & $100\mu\text{F}$ for C_0 .

$$C_{1,2} \geq \frac{I_o}{f_s * \Delta V_{C1,C2}} \quad (7)$$

$$C_{2,3} \geq \frac{V_o}{\Delta V_{C2,C3} * f_s * R} \quad (8)$$

$$C_0 = \frac{V_o * (D)}{\Delta V_{C0} * f_s * R} \quad (9)$$

III. SIMULATIONS AND RESULTS

The single switch enhanced gain SEPIC converter is simulated in MATLAB/SIMULINK by choosing the parameters listed in Table 1. The switch is MOSFET with constant switching frequency 40kHz. MATLAB is a high-performance language for technical computing. It integrates computation, visualization, and programming in an easy way to use environment where problems and solutions are expressed in familiar mathematical notation. SIMULINK is a software package for modelling, simulating, and analysing dynamical systems.

A dc input voltage of 30V gives an dc output of 304.5V. Figure 4 shows the input voltage and current. Figure 5 shows

TABLE I
SIMULATION PARAMETERS OF SINGLE SWITCH ENHANCED GAIN SEPIC CONVERTER

Parameters	Specification
Input voltage V_{in}	30 V
Output voltage V_o	314.95 V
Inductor L_1	1000 μH , 20A
Capacitor C_1, C_2	4.7 μF , 120V
Capacitor C_3, C_4	50 μF , 120V
Capacitor C_0	150 μF , 220V
Switching frequency	70 KHz
Output load	222 Ω
Duty ratio	73.91 %

the output voltage and current. Figure 6 shows the gate pulse and voltage stress across switch S. The voltage stress of switch S is 110.4V.

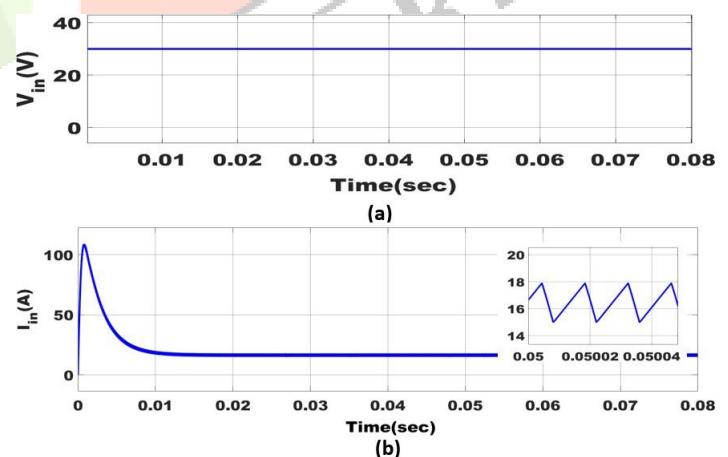

Fig. 4. (a) Input Voltage (V_{in}) and (b) Input Current (I_{in})

The voltage across capacitors V_{C1} is 97.36V, V_{C2} is 109V, V_{C3} is 97.8V and V_{C4} obtained as 98.8V which is shown in Figure 7.

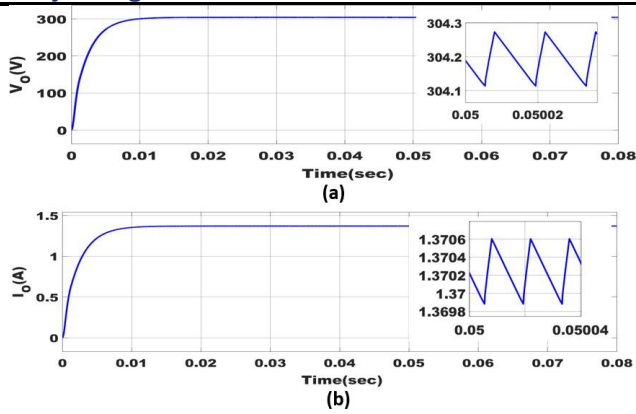

Fig. 5. (a) Output Voltage (V_o) and (b) Output Current (I_o)

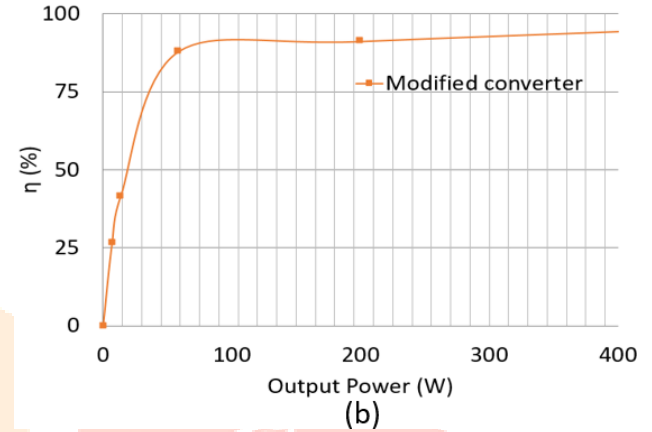
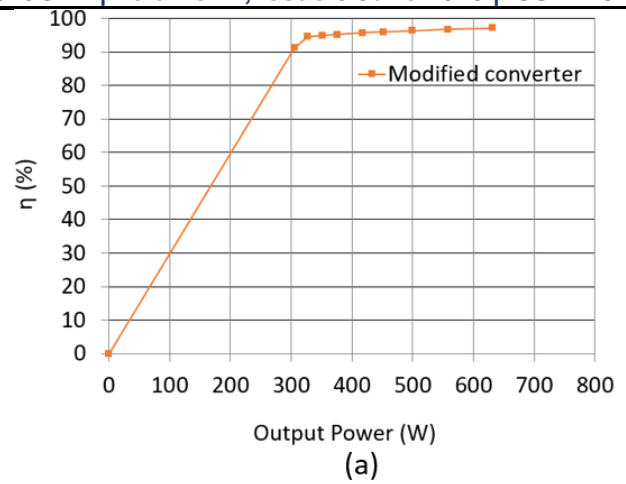

Fig. 8. Efficiency Vs Output Power for (a) R load, (b) RL load

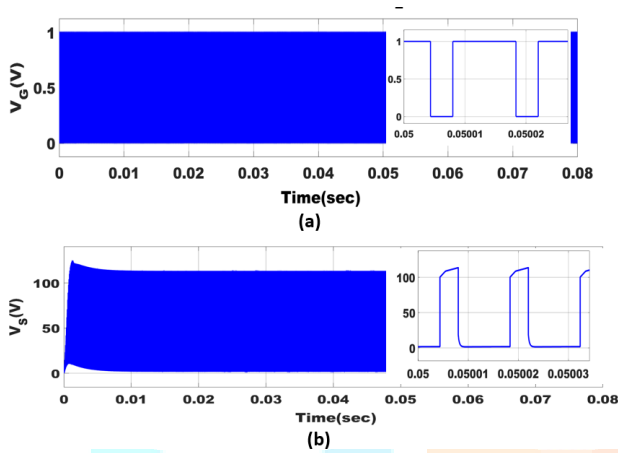

Fig. 6. (a) Gate Pulse of S (b) Voltage Stress of $S(V_s)$

in figure 10. The plot of Output voltage ripple Vs Frequency is shown in figure 11.

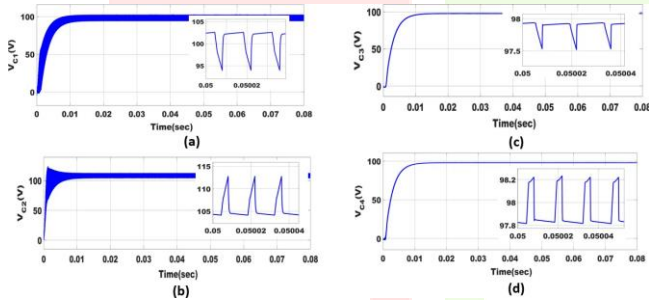

Fig. 7. Voltage across Capacitor (a) V_{c1} , (b) V_{c2} , (c) V_{c3} , (d) V_{c4}

IV. PERFORMANCE ANALYSIS

Efficiency of a power equipment is defined at any load as the ratio of the power output to the power input. Here the efficiency Vs output power with R load and RL load for Single switch enhanced gain SEPIC converter is done and shown in Fig. 8. The maximum converter efficiency for R & RL load are obtained as 97% and 96.7% .

The plot of Voltage gain VS duty ratio is shown in figure 9. The plot of Output voltage Vs duty ratio is shown

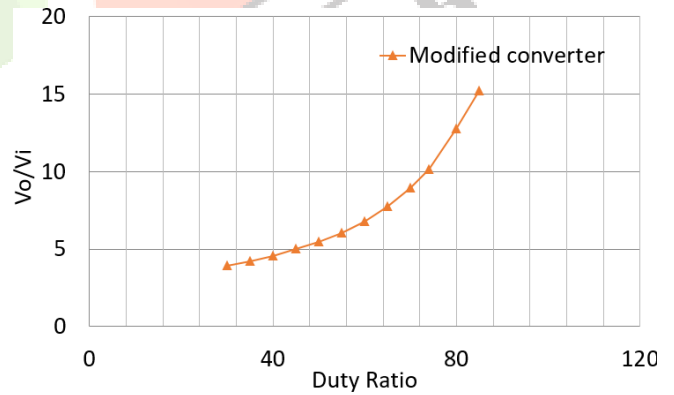

Fig. 9. Voltage Gain Vs Duty Ratio

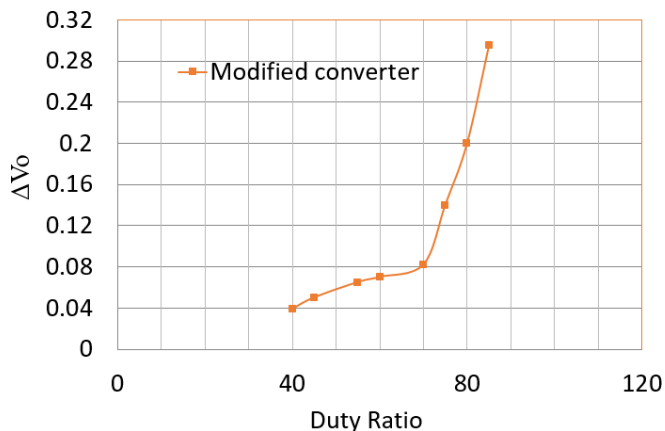

Fig. 10. Output Voltage Ripple Vs Duty Ratio

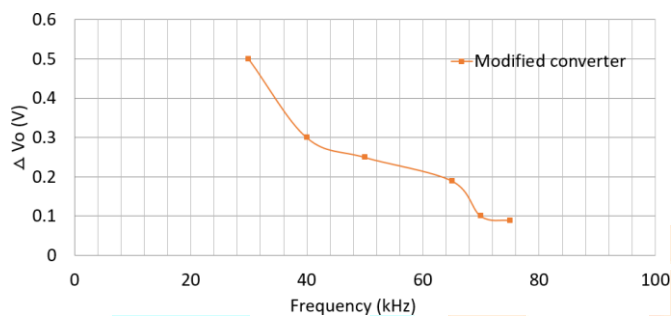

Fig. 11. Output Voltage Ripple Vs Frequency

V. STABILITY ANALYSIS

For the analysis of the stability of the proposed converter, the transfer function of the converter is obtained by considering the two modes and the corresponding mathematical equations. From the bode plot, it can be inferred that the system offers a gain margin of 160 dB and phase margin of 95 degree. Also the gain crossover frequency is less than phase crossover frequency. Hence it is evident that the system is stable.

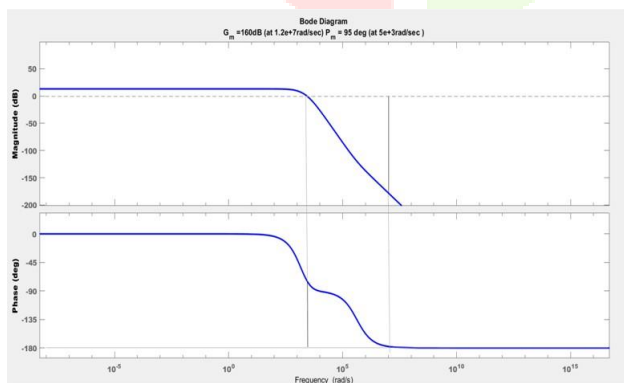

Fig. 12. Bode plot for Single switch enhanced gain SEPIC converter

VI. COMPARITIVE STUDY

The comparison between single switch enhanced gain SEPIC converter & High static gain SEPIC converter is given in table 2. On the comparison it can be observed that, keeping same values for input voltage 30V & switching frequency as 70kHz, the required output voltage is 304.5V for single switch enhanced gain converter and 199.5V for SEPIC boost converter. And the efficiency of single swicth enhanced gain SEPIC converter is 95.16% .

TABLE II
COMPARISON BETWEEN HIGH STATIC GAIN CONVERTERS & PROPOSED CONVERTER

Parameters	Single Switch modified SEPIC converter	High static gain modified SEPIC converter
No. of switches	1	2
No. of inductor	1	2
No. of capacitor	5	3
Voltage gain	10.14	6.67
Efficiency	95.16%	97%
Switching frequency	70KHz	70KHz

Table 3 shows the component wise comparison between single switch enhanced gain SEPIC converter & other converters. Comparison is based on the components used in the different converters. From table it can be observed that, the number of total components used in transf.

TABLE III
COMPARISON BETWEEN SINGLE SWITCH ENHANCED GAIN SEPIC CONVERTER & OTHER CONVERTERS

Converters	High static gain modified converter	SEPIC based single switch buck-boost	A DCM high frequency step up SEPIC converter	A novel soft-switched DCM SEPIC converter	Single Switch Modified SEPIC converter
Switches	2	1	2	2	1
Inductors	1	4	3	3	1
Capacitors	3	6	3	4	5
Diodes	1	3	2	3	5

VII. EXPERIMENTAL SETUP

For the purpose of implementing hardware, the input voltage is reduced to 3V and the switching pulses are generated using TMS320F28335 controller. The switches used are MOSFET IRF540 & diodes are IN 5817. Driver circuit is implemented using TLP250H, which is an optocoupler used to isolate and protect the microcontroller from any damage and also to provide required gating to turn on the switch.

Experimental setup of single switch enhanced gain SEPIC converter is shown in Fig. 13. Input 3V DC supply is given from DC source. The switching pulses are taken from TMS320F28027F microcontroller to driver circuit. Thus an

output voltage of 21.2V, 70kHz is obtained from power circuit that is shown in Figure 14. Output voltage of converter is taken from the DSO oscilloscope. .

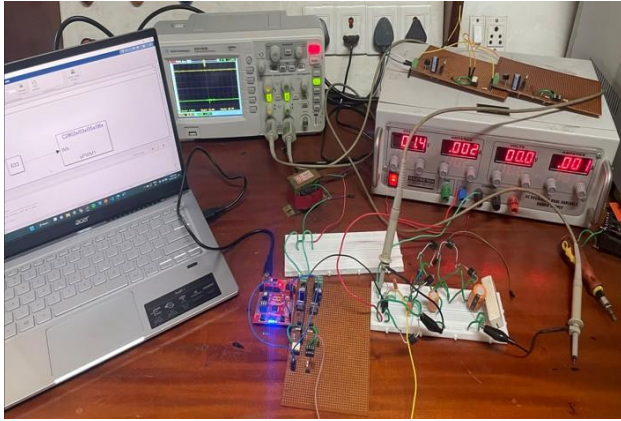

Fig. 13. Experimental Setup

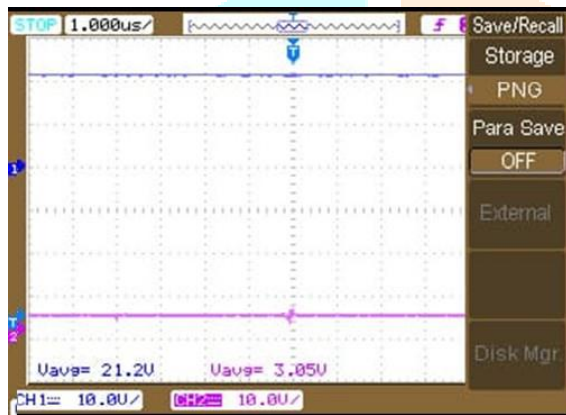

Fig. 14. Output voltage of proposed converter

VIII. CONCLUSION

A single switch enhanced gain SEPIC converter is proposed in this report, which can work in a wide input voltage range. Single switch enhanced gain SEPIC converter is the obtained by intergrating a high static gain SEPIC converter with voltage multiplier cell and by eliminating one of its switches. Also the converter become more efficient by replacing one of its inductor by a diode. Thus the converter has characteristics of high gain, high efficiency, high integration, few power devices, less switching losses and easy to control. In the proposed converter, there is only one switch that reduces stress of the components in the converter. Moreover, the proposed converter provides high gain with low ripple. The single switch enhanced gain SEPIC converter has characteristics of enhanced gain, high integration, high efficiency and low output voltage ripple. For a power of 480W, the proposed enhanced gain converter provides an efficiency 95.16% . The control

of the proposed enhanced gain con- verter is implemented using TMS320F28027F microcontroller. Converter prototype of 3V provides a performance with an output voltage of 27.2V, considering the drop across the components. The overall analysis confirms that the proposed enhanced gain converter can be used for renewable energy applications.

REFERENCES

- [1] Fabio Inocencio Kravetz and Roger Gules. Soft-Switching High Static Gain Modified SEPIC Converter. *IEEE journal of emerging and selected topics in power electronics* , Vol. 9, No. 6, Dec 2021
- [2] Roger Gules. A Modified SEPIC Converter With High Static Gain for Renewable Applications. *IEEE transaction on power electronics* , Vol. 29, No. 11, Nov 2014
- [3] Shanshan Gao. A DCM High Frequency High Step Up SEPIC-Based Converter with Extended ZVS Range. , *IEEE Journal of Emerging and Selected Topics in Power Electronics*, 2020
- [4] Sajad Arab Ansari and Javad Shokrollahi Moghani. A Novel High Voltage Gain Noncoupled Inductor SEPIC Converter. *IEEE Transaction on industrial electronics* , , September 2019.
- [5] F. M. Shahir, E. Babaei, and M. Farsadi. Analysis and design of voltage-lift technique-based non-isolated boost DCDC converter. *IET Power Electron* , vol. 11, no. 6, pp. 10831091, Nov. 2017,
- [6] K.-B. Park, G.-W. Moon, and M.-J. Youn. Nonisolated high step-up boost converter integrated with sepic converter., *IEEE Trans. Power Electron*, vol. 25, no. 9, pp. 22662275, Sep. 2010
- [7] H. Ardi, A. Ajami, and M. Sabahi. A novel high step-up DCDC converter with continuous input current integrating coupled inductor for renewable energy applications. *IEEE Trans. Ind. Electron*, vol. 65, no. 2pp
- [8] Ahmad Alzahrani, Pourya Shamsi and Mehdi Ferdowsi. A Novel Interleaved Non-isolated High-gain DC-DC Boost Converter with Greinacher Voltage Multiplier Cells. *6th International Conference on Renewable Energy and Applications, 2017*, 2017
- [9] Wuhua Li, Yi Zhao, Yan Deng and Xiangning He, Interleaved Converter With Voltage Multiplier Cell for High Step-Up and High-Efficiency Conversion , *IEEE Transactions on Power Electronics*, vol. 25, no. 9, September 2010
- [10] Luo-wei Zhou, Bin-xin Zhu, Quan-ming Luo and Si Chen. Interleaved non isolated high step-up DC/DC converter based on the diode-capacitor multiplie. *IET Power Electronics*, , Feb. 2014.