



# DEVELOPMENT OF BI DIRECTIONAL DC/DC CONVERTER WITH DUAL BATTERY ENERGY STORAGE FOR ELECTRIC VEHICLE SYSTEM

Mrs.M.Sangeetha.,ME.,<sup>1</sup>,

M.Azhagudhurai<sup>2</sup>, S.Gokula Krishnan<sup>3</sup>, A.Premnath<sup>4</sup>, R.Rakesh<sup>5</sup>

1 ASSISTANT PROFESSOR 2,3,4,5 UG SCHOLAR

ELECTRICAL AND ELECTRONICS ENGINEERING

THE KAVERY ENGINEERING COLLEGE, MECHERI, SALEM, TAMILNADU, INDIA

## ABSTRACT

New energy vehicles play a positive role in reducing carbon emissions. To improve the dynamic performance and durability of vehicle powertrain, the hybrid energy storage system of “fuel cell/power battery” is more used in new energy vehicles. Bidirectional DC–DC converters with wide voltage conversion range are essential for voltage matching and power decoupling between battery and vehicle bus, helping to improve the low input voltage characteristics of super capacitors and realize the recovery of feedback energy. In recent years, the topologies of bidirectional converters have been widely investigated and optimized. Aiming to obtain bidirectional DC–DC converters with wide voltage conversion range suitable for hybrid energy storage system, a review of the research status of non-

isolated converters based on transformer are presented. Additionally, an evaluation system for bidirectional DC–DC topologies for hybrid energy storage system is constructed, providing a reference for designing bidirectional DC–DC converters. The performance of eight typical non-isolated converters and seven typical isolated converters are comprehensively evaluated by using this evaluation system. On this basis, issues about DC–DC converters for hybrid energy storage system are discussed, and some suggestions for the future research directions of DC–DC converters are proposed.

**Key words :** Bidirectional dc/dc converter, main energy storage, an auxiliary energy storage, MATLAB/Simulink

## 1. INTRODUCTION

In recent years, alternative energy systems and applications like eco-friendly cars have been focused on due to the exhaustion of fossil fuel and severe environmental pollution. Bidirectional dc-dc converters are one of the most important energy conversion system in the applications such as plug-in hybrid electric vehicle (PHEV), fuel-cell vehicle, renewable energy system, and uninterruptible power supply (UPS). In PHEV system, the bidirectional dc-dc converter acts as an energy transfer system from a low voltage battery to a DC-link that is an input voltage of an inverter for operating a vehicle motor, or from a DC-link to a battery for charging regenerative energy. In the renewable energy systems, including fuel cell systems, photovoltaic systems, and wind power systems, the bidirectional dc-dc converter is essential for electric power conversion between a low voltage battery where dump power is charged and a high voltage source for home appliances. The bidirectional dc-dc converter is divided into an isolated type and a non-isolated type. On the other hand, the non-isolated bidirectional dc-dc converter has high efficiency due to simple structure. Recently, soft-switching techniques are applied to the non-isolated bidirectional dc-dc converter to achieve soft-switching of power switches in a wide range of load and reduce switching noises.

## 2. LITERATURE REVIEW

**2.1 YIN, Y., ZENG, Y., CHEN, X., FAN, Y.: “A DIGITAL METHOD OF POWER SHARING AND CROSS-REGULATION SUPPRESSION DC-DCCONVERTER”:overview.J.In,13(2016).**

This paper presents a digital method to regulate the single-inductor multiple-input multiple-output (SI-MIMO) dc-dc converter, which can integrate renewable sources and loads as the hybrid renewable energy system with less components.

**2.2 WANG, X., WANG, J.T.,ZHANG , X., SONG, J.: “A MULTI INPUT DC DC CONVERTER TOPOLOGIES In: IEEE FAIBLE TENSION FAIBLE COMMUNICATION (FTFC)”,Paris,pp 1-4(2013)**

Multi-port converters have fewer components count and less conversion stage than the traditional power processing solution which adopts several independent two-port converters. This paper emphasis on the use of a single power processing stage to interface multiple power inputs integrates power conversion for a hybrid power source. The classification of various multiport dc-dc converters topologies both isolated and non isolated are studied and the features are listed.

**2.3 XU, B., XU, L.D., CAI, H., XIE, C., HU, J., BU, F: “STRUCTURE OF MULTI INPUT MULTI OUTPUT DC-DC CONVERTER”. IEEE TRANS.Ind.Inf.10(2),1578-1586(2014)**

In this study, a new structure for multi-input multi-output (MIMO) dc-dc boost converter is proposed. The number of inputs and outputs of the converter are arbitrary and independent from each other. The proposed topology has the advantages of both dc-dc boost and switched-capacitor converters. This converter is proper to use in applications like

photovoltaic or fuel cell systems. The main advantages of the proposed structure are possibility of using energy supplies with different voltage-current characteristics, continuous input current, high voltage gain without high duty cycle, and possibility of performing at high switching frequencies.

### 3. WORKING PRINCIPLE

This bidirectional dc-dc converter has galvanic isolation between the load and the fuel cell, bidirectional power flow, voltage matching capabilities, and quick response to transient load demand, among other advantages. Renewable electric power generating systems have recently been developed using clean energy resources such as solar arrays and wind turbines. When the dc bus voltage is low, the bidirectional dc-dc converter is frequently used to transmit solar energy to the capacitive energy source while delivering energy to the load. The majority of contemporary bidirectional dc-dc converters have a circuit configuration like the one shown in the diagram, which is defined by a current or voltage provided on one side.

The bidirectional dc-dc converter can be classified as buck or boost depending on where the supplementary energy storage is located. Energy storage is put on the high voltage side in the buck type, whereas it is positioned on the low voltage side in the boost type.

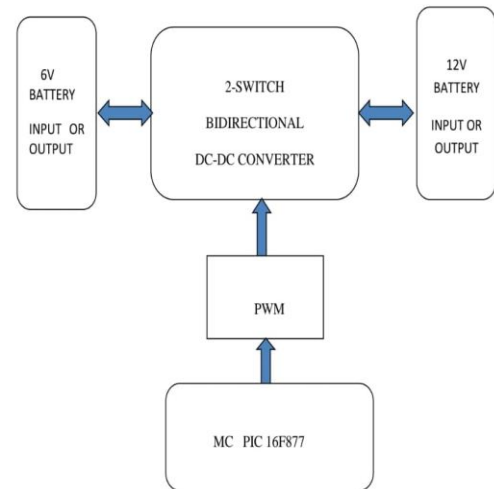

Fig No:1 Block Diagram

### 4. MAJOR COMPONENTS

PIC MICROCONTROLLER  
BUCK CONVERTER  
BOOST CONVERTER  
MOSFET  
LCD DISPLAY  
BATTERY

#### 1. PIC MICROCONTROLLER

The microcontroller that has been used for this project is from PIC series. PIC microcontroller is the first RISC based microcontroller fabricated in CMOS (complimentary metal oxide semiconductor) that uses separate bus for instruction and data allowing simultaneous access of program and data memory. The main advantage of CMOS and RISC combination is low power consumption resulting in a very small chip size with a small pin count. The main advantage of CMOS is that it has immunity to noise than other fabrication techniques.

## BUCK CONVERTER

A buck converter is a step-down DC to DC converter. Its design is similar to the step-up boost converter, and like the boost converter it is a switched-mode power supply that uses two switches (a transistor and a diode), an inductor and a capacitor. The simplest way to reduce a DC voltage is to use a voltage divider circuit, but voltage dividers waste energy, since they operate by bleeding off excess power as heat; also, output voltage isn't regulated (varies with input voltage). Buck converters, on the other hand, can be remarkably efficient (easily up to 95% for integrated circuits) and self-regulating, making them useful for tasks such as converting the 12–24 V typical battery voltage in a laptop down to the few volts needed by the processor.

## BOOST CONVERTER

A boost converter (step-up converter) is a power converter with an output DC voltage greater than its input DC voltage. It is a class of switching-mode power supply (SMPS) containing at least two semiconductor switches (a diode and a transistor) and at least one energy storage element. Filters made of capacitors (sometimes in combination with inductors) are normally added to the output of the converter to reduce output voltage ripple.

## MOSFET

Metal–oxide–semiconductor field-effect transistor (MOSFET) is based on the modulation of charge concentration by a MOS capacitance between a body electrode and a gate electrode located above the body

and insulated from all other device regions by an oxide.

## 5. CONCLUSION

In this project, a soft-switching bidirectional dc-dc converter using a lossless active snubber has been proposed. In the proposed converter, ZVS of the main switches and ZCS of the auxiliary switches are always achieved. In addition, by utilizing the active snubber, there is no reverse-recovery problem of the intrinsic body diodes of the switches. Since the active snubber operates in a short time, the increased conduction loss of the proposed converter is relatively lower than the soft-switching bidirectional converter. Thus, the overall efficiency improvement is achieved over a wide range of load. Moreover, by adjusting according to loads, it is possible to achieve optimized overall efficiency throughout the whole loading range.

## 6.SNAPSHOT OF KIT

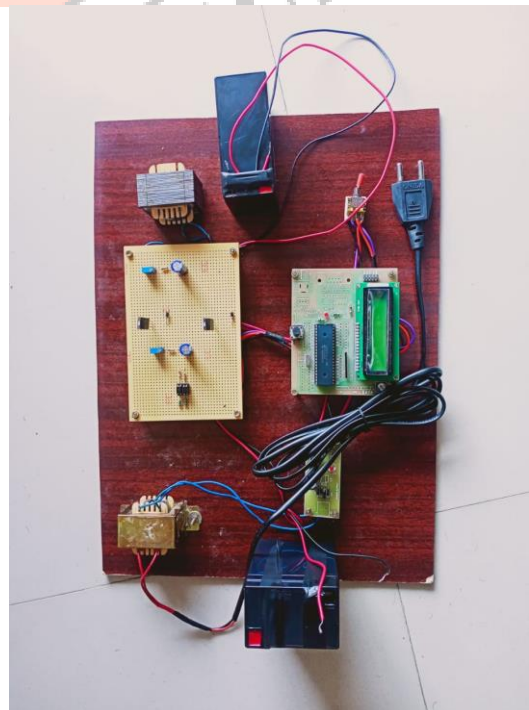

## 7. REFERENCE

- [1] Yin, Y., Zeng, Y., Chen, X., Fan, Y.: Multi port dc dc converter an overview. *J. Ind. Inf. Integr.* 1, 3–13 (2016)
- [2] Wang, X., Wang, J.T., Zhang, X., Song, J.: A multi input multi output converter In: *IEEE Faible Tension Faible Consommation (FTFC)*, Paris, pp. 1–4 (2013)
- [3] 4. Xu, B., Xu, L.D., Cai, H., Xie, C., Hu, J., Bu, F.: Ubiquitous data accessing method in based// information system for emergency medical services. *IEEE Trans. Ind. Inf.* 10(2), 1578–1586 (2014)
- [4] 5. Kolici, V., Spaho, E., Matsuo, K., Caballe, S., Barolli, L., Xhafa, F.: Implementation of a medical support system considering P2P and IoT technologies. In: *Eighth International Conference on Complex, Intelligent and Software Intensive Systems*, Birmingham, pp. 101– 106 (2014)
- [5] Sullivan, H.T., Sahasrabudhe, S.: Envisioning inclusive futures: technology-based assistive sensory and action substitution. *Futur. J.* 87, 140–148 (2017)

