



IOT BASED MONITORING SYSTEM FOR COMATOSE PATIENTS

S. SATHYARAJ¹, S. SANJAI², G. SANTHOSH KUMAR³, V. SAMUVELKAMALESAN⁴, V. VENKATESHWARAN⁵

1 ASSISTANT PROFESSOR 2,3,4,5 UG STUDENT
BIO MEDICAL ENGINEERING

GNANAMANI COLLEGE OF TECHNOLOGY, TAMILNADU, INDIA

ABSTRACT

Coma is a state of unconsciousness where the patient fails to respond. These patients need utmost care and observations. This paper presents a continuous monitoring and recording of patient data without human intervention. If there are any sudden changes occur in the normal range of body parameters such as body temp falls or rise, blood pressure (B. P.) increases or decreases causing high or low B.P. where both are not stable conditions for better health, then it has facility to automatically alert the medical person. The development sensor identifies the patient development and furthermore produces an alarm message to the clinical individual. As torpid misfortunes their sensation for urine, clinical individual necessities to persistently screen urine yield, hence we are utilizing ultrasonic sensor to beware of urine level. Clinical individual can monitor patient utilizing login to the framework. The software IoT API we are using is Thing Speak.

Keywords: Blood pressure, Ultrasonic sensor, robust asymmetric and Medical person

1. INTRODUCTION

In last decades' health issues are raising day to day life at very high speed every day. One of the major health issues is a coma. Coma is a deep state of persistent sleep Unconsciousness is a covert government of persevering rest where an individual can't be stirred; he neglects to react regularly to excruciating upgrades, light, or sound; comes up short on a typical wake-rest cycle; and doesn't start intentional activities. Sluggish can't purposely feel, talk or move. Trance states can be brought about by different things, for example, an extreme physical issue to the head that harms the cerebrum, diseases in the mind, mind harm because of absence of oxygen for a really long time, taking a lot medication (glut) or different medications, might be because of compound irregular characteristics in the body from different ailments. Healthcare is one of the global challenges for humanity. According to the constitutions of the World Health Organization (WHO) the highest attainable standard of health is a fundamental right for an individual. To keep individuals healthy, an effective and readily accessible modern healthcare system is a prerequisite. A modernized healthcare system should provide better healthcare services to people at any time and from anywhere in an economic and patient friendly manner. According to Shivleela and Dr. Sanjay (2018) in traditional method, doctors play an important role in health check up because this process requires a lot of time for registration, appointment, check up and then reports are generated later. Due to this lengthy working process people tend to ignore the checkups or postpone it. According to Sathya, Madhan and Jayanthi (2018), the increased rate of medically challenged people has made remote healthcare become a part of our life. Okemiri Henry Anayo, Computer Science Department, Faculty of Physical Sciences, Alex Ekwueme Federal University Ndufu Alike, Nigeria Achi Ifeanyi Isaiah, Uche-Nwachi Edward, Nnakwusie Doris, Afolabi Idris Yinka, Nnabu-Richard Nneka E, Computer Science Department, Faculty of Physical Sciences, Alex Ekwueme Federal University Ndufu Alike, Nigeria According to Naveen and Hardeep (2011), Coma is sometimes called persistent vegetative state and is a profound or deep state of unconsciousness, Persistent vegetative state is not brain-death. An

individual in a state of coma is alive but unable to move or respond to his or her environment. Coma may occur as a complication of an underlying illness, or as a result of injuries, such as head trauma. Because of expanding work cost, medical institutions would constrain to decrease nursing staff for patients. There are lots of IOT devices these days used to monitor the health of patients over the internet. Health experts are also taking advantage of these smart devices to keep an eye on their patients. With lots of new healthcare technology start-ups, IOT is rapidly revolutionizing in the healthcare industry (Rishabh, 2018) In this paper, a secured IOT-based healthcare monitoring system for coma patients is introduced. To achieve system efficiency simultaneously and robustness of transmission within public IOT-based communication networks, a robust asymmetric cryptograph is used to construct two communication mechanisms for ensuring transmission confidentiality and security which can help patients to be monitored remotely. By this, on the basis of derived data if a patient is in a critical situation, an immediate instruction can be given to the person who is in charge. The system will play a vital role to reduce labor cost, ease of access from anywhere at any time and will be helpful in making effective decision.

2. LITERATURE SURVEY

REAL-TIME HEALTH MONITORING SYSTEM USING IOT FOR COMATOSE PATIENTS

Internet of Things (IoT) based smart devices has been reshaping human life through assisting in making smarter decisions and yielding response to the users based on analysis of data. Among various aspects of life, patients require continuous care and uninterrupted monitoring. IoT makes this possible by providing real-time monitoring of various health conditions of patients. Specifically, IoT based health monitoring systems act as an effective solution for the patients and doctors. In this paper, a soft real-time health monitoring system based on an android application and a web-based monitoring portal is developed for comatose patients. Using the developed system, a doctor can monitor conditions of the patients. The system is developed using a Raspberry pi microcomputer and the health related sensors. The system collects the information like heartbeat rate, blood pressure, urine level, temperature, humidity, and motion detection using the sensors. It alerts doctor if any parameter exceeds the normal limit. Moreover, it also updates status on the database and the developed application. The proposed system can effectively able to monitor the health condition of a comatose patient in real-time using IoT.

IOT BASED COMA PATIENT MONITORING SYSTEM USING WEARABLE SENSORS

Coma can be classified into two stages vegetative state (VS) and minimally conscious state (MCS). In VS there are no signs of consciousness which is in contrast to that of MCS. The record of the comatose transition from VS to MCS is not effectively sustained. In the present hospital, a caretaker is mandatorily needed to supervise the patient continuously. Such methods of supervision have a greater threat due to human errors. This impact can be surpassed by following the proposed system which focuses on monitoring and alerting the caretaker about the transition from VS to MCS, continuously monitor the vitals such as heartbeat, pulse rate using relative biometric sensors of comatose, monitor the physiological signals to understand the patient's emotional status, and change in behavioural approach for speeding up the healing process by unifying the wireless sensors to ESP8266 NodeMCU microcontroller board.

IOT BASED HEALTHCARE SYSTEM FOR COMA PATIENT

Coma is a state of unconsciousness where the patient fails to respond. These patients need utmost care and 24*7 observations. This paper presents a continuous monitoring and recording of patient data without human intervention. If there are any sudden changes occur in the normal range of body parameters such as body temp falls or rise, blood pressure (B. P.) increases or decreases causing high or low B.P. where both are not stable conditions for better health, then it has facility to automatically alert the medical person. The movement sensor detects the patient movement and also generates an alert message to the medical person. As comatose losses their sensation for urination, medical person needs to continuously monitor urine output, thus we are using ultrasonic sensor to check on urine level. Medical person can keep the track of patient using login to the system. The software IoT API we are using is Thing Speak.

A COMATOSE PATIENT MONITORING SYSTEM BASED ON IOT

A sophisticated system that allows real-time monitoring and analysis of patients' vital signs in a comatose condition is the IoT (Internet of Things) based monitoring system for comatose patients. The system uses a number of sensors, including blood pressure, oxygen saturation, temperature, and pulse sensors, to gather and send data to a central server over a wireless network. To find patterns and trends in the

patient's condition, the collected data is examined using machine learning algorithms. The device also has an alarm system that goes out when it detects a critical change in the patient's vital signs. The technology can greatly lessen the strain of medical workers and offer constant monitoring, ensuring that any condition that could be life-threatening is swiftly treated.

3. EXISTING SYSTEM

The health monitoring system consists of different sensors which are divided into two categories. One is used for monitoring vitals of the comatose and second is used for detecting any physical changes occur in the comatose. Here, temperature and blood pressure are the two vitals recorded and monitored to understand health status of a comatose. The other two sensors are MEMS accelerometer sensor and Eye blink sensor which are used for detecting any physical changes that occurring comatose. These sign switch gives data are recorded and checked consistently to comprehend the body working. In the event that the arrangements of these detected signs which are outside ordinary ranges normally suggest the requirement for some consideration or conceivable departure to a more elevated level of treatment during which we alert the doctor.

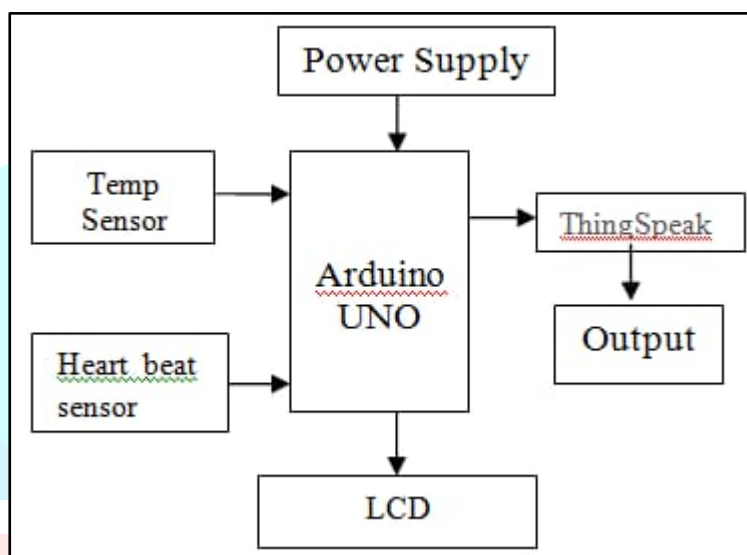

4. PROPOSED SYSTEM

A health observing system comprises of variety of sensors connected to the patient and they communicate that data via the processing Think speak. In this project, Node MCU is acts as a data junction node as well as a processor. The patient and doctor smart phone or computers are used as a monitoring device. The sensors are used to measure the health parameters of patient after these parameters are acts as readings and finally converted into signals. These signals are provided for processing to Node MCU. Then Node MCU displays the information on a monitor and also stores the information over the cloud with the help of IoT.

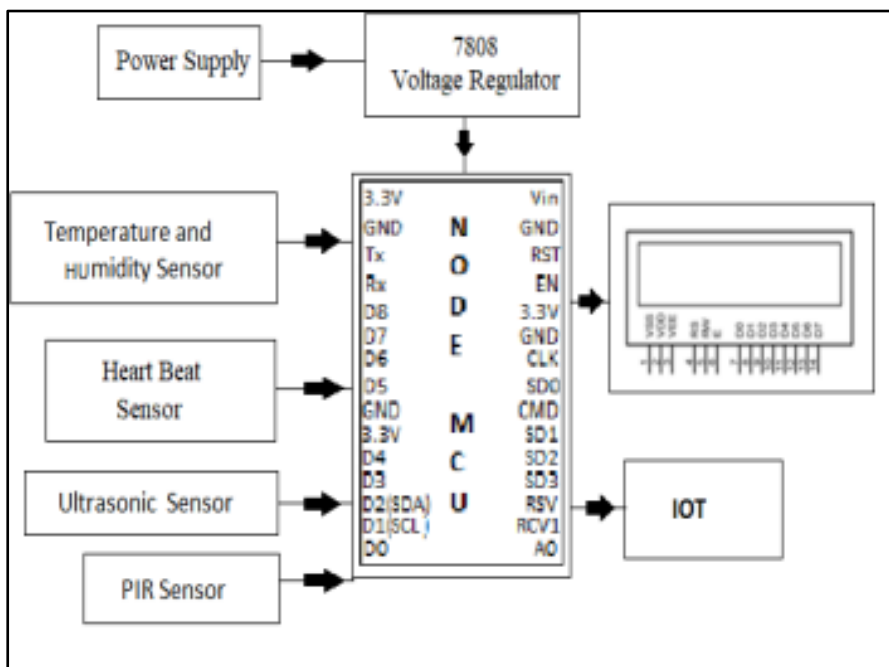

5. CONCLUSION

The aim of our proposed system is to build easily accessible design that the patient's critical information is conveyed quickly to the doctor is achieved. The designed model leads to the better and effective health care service to comatose and the collected data is networked worldwide with the help of internet and communication which provide a quick response. The IoMT market involves variety of smart devices, such as wearable and medical/vital monitors, in the home, or hospital; and associated real-time location, tele health and other services. So with the help of these devices doctor can easily examine his patient at anytime, anyplace. In this proposed system vital parameters such as B. P., temperature is monitored. Movement sensor and eye blink sensor is used to detect motion of body parts of comatose. Ultrasonic sensor is used for urine level monitoring. Also the designed system is affordable to the patients.

6. REFERENCES

- [1] Geethanjali R., MajidhaFathima K. M., Harini S., Sabitha M., "Health monitoring for coma patients", International Journal of Emerging Research & Development, Volume 2, Issue 3,2019.
- [2] Dr.R. JosphineLeelaM.E, P K. Hamsageetha, P. Monisha, S. Yuvarani, "Body Movement and Heart Beat Monitoring for Coma Patient Using IoT", International Journal of Innovative Research in Science, Engineering and Technology, Vol. 7, Special Issue 2, March2018.
- [3] S. Sandeep, Dr. P. Esther Rani, G. Sumalatha, "Monitoring of Health Parameters by Using Raspberry Pi", International Journals of Advanced Research in Computer Science and Software Engineering, (Volume8, Issue-4), 2018.
- [4] EmnaMezghani, Ernesto Exposito, and Khalil Drira., "A ModelDriven Methodology for the Design of Autonomic and Cognitive IoT-Based Systems: Application to Healthcare", IEEE transactions on emerging topics in computational Intelligence, VOL. 1, NO. 3, JUNE 2017.
- [5] SnehaChowdaryKoganti, Dr. H N Suma, Appaji M. Abhishek "Analysis and Monitoring of Coma Patients using Wearable Motion Sensor System", International Journal of Science and Research (IJSR), Volume 4 Issue 9, September2015.
- [6]. T. O. Prasetyono and N. Kusumastuti, "Optimal Time Delay of Epinephrine in One-per-mil Solution to Visualize Operation Field", Journal of Surgical Research, 2019.
- [7]. S. Mathusudhan, A L Nilla, A Pradeep, S Manibharathi and J. Geetha Ramani, "Employ Health Legacy", Journal of Emerging Technologies and Innovative Research (JETIR), June 2019.
- [8]. S. Sampeter and S. Padmavath, "An improved health monitoring system for coma patients using internet of things", (IJETIE), vol. 5, pp. 408-412, 2019.
- [9]. Ganesh, "Health monitoring system using Rasbery pi and IoT", Oriental Journal of Computer Science and Technology, vol. 12, 2019, ISSN 0974-6471.
- [10]. Nookhao. V. Thananant and T. Khunkhao, "Development of IoT Heartbeat and Body Temperature Monitoring System for Community Health Volunteer", 2020 Joint International Conference on Digital Arts Media and Technology with ECTI Northern Section Conference on Electrical Electronics Computer and Telecommunications Engineering (ECTI DAMT & NCON), pp. 106-109, 2020.
- [11]. T. E. Dietz and P. H. Hackett, "High-Altitude Medicine" in Travel Medicine, Elsevier, pp. 387-400, 2019.
- [12]. S. Chakraborty, S. Aich and H. C. Kim, "A secure healthcare system design framework using blockchain technology", Proc. 21st Int. Conf. Adv. Commun. Technol., pp. 206-264, 2019.
- [13]. F. laport, F.J. Vazquez-Araujo, P.M. Castro and A.Dapena, "Hardware and Software for Integrating BrainComputer Interface with Internet of Things", International Work-Conference on the Interplay Between natural and Artificial Computatin, pp. 22-31, 2019.
- [14]. M. Wojcikowski and B. Pankiewicz, "Photoplethysomgraphic time-domain heart rate measurement algorithm for resource-constrained wearable devices and its implementation", Sensors, vol. 20, 2020.