



# INTERNATIONAL JOURNAL OF CREATIVE RESEARCH THOUGHTS (IJCRT)

An International Open Access, Peer-reviewed, Refereed Journal

## IoT Based Surveillance And Monitoring System For Child Stuck Inside The Car

T. Narendra Kumar<sup>1</sup>, E. Venkata Sagar<sup>2</sup>, P. Bhavya Sri<sup>3</sup> N. Yagneswara Reddy<sup>4</sup>

<sup>1</sup>Assistant Professor, Department of Electronics & Communication Engineering

<sup>2</sup>Under Graduates, Department of Electronics & Communication Engineering

<sup>3</sup>Under Graduates, Department of Electronics & Communication Engineering

<sup>4</sup>Under Graduates, Department of Electronics & Communication Engineering

DVR & Dr. HS MIC College of Technology, Kanchikacherla, Andhra Pradesh India

tanneru.narendra903@gmail.com<sup>1</sup>

**Abstract:** The goal of this project is to create an IoT-based surveillance and monitoring system for the safety of a child or pet in a car. It can be used to locate a baby who has been left or trapped inside a vehicle. It is also capable of detecting motion performed by a person in a vehicle. The IR Sensor detects living organisms inside the car cabin by detecting infrared radiation waves. Using the DHT11, MAX30102, and MQ 135 this project monitors the temperature, pulse, and other toxic gases released inside the car. We are using a MEMS sensor to detect whether the baby has fallen out of the baby cradle. we can control the glasses of the car by using the servo motor. The WI-FI (ESP8266) module uploads all sensor values to THINGSPEAK. The Arduino Mega 2560 (AT Mega 2560) microcontroller. This system can also be used to intentionally leave children in the car. The sensors are the project's beating heart. We can monitor the baby's condition inside the car because all sensor values are uploaded to THINGSPEAK. If an unwelcome event occurs, we can use the servo motor to control the car's glass. Apart from the smart phone application, this System also has a Buzzer as an alternative to a security alarm and requested immediate assistance from the people in the surrounding area. If their parents leave, the proposed system will monitor the children, which can be installed and used for real.

**Index Terms:** ARDUINO Mega 2560, ESP8266, DHT11, MAX30105, MEMS, MQ135-Gas Sensor, THING SPEAK, IoT

### I.INTRODUCTION

Many scientists around the world have reported on cases involving the death of a child in a vehicle. It happens almost every year as a result of parents' negligence in leaving their children alone in a car. Tragic events occur on a regular basis, making everyone fearful and concerned. When a driver arrives safely at their destination, they may forget or overlook the presence of children in the vehicle due to his hasty exit from

the vehicle. A baby is vulnerable to dehydration, which can result in coma or, in the worst-case scenario, death. To prevent incidents like this from occurring, a vehicle must be equipped with an alarm and sensor that can be installed in the vehicle. If the sensor detects the presence of a human body or any movement, it will make an announcement and notify the parents by updating the sensor values in Thing Speak, as the proposed system does.

This system required a technique for detecting interior movement or the voice of a child who had been left in the car and alerting the parent if any movement occurred. Aside from the proposed system's simplicity, the cost will be kept as low as possible in order to make it affordable for installation in any type of vehicle, regardless of quality or brand. Even though the vehicle's alarm system has been activated, the alarm's primary purpose is to keep the car safe from outside intrusion, not from inside. The proposed system will detect any motion movement from the interior of the vehicle. This project can be useful in monitoring the baby's condition inside the car by using the sensors.

**The Internet of Things (IoT)** is a new and promising technology that gives every device an identity by assigning it an IP address. IoT can communicate with all items in the universe through the internet, allowing systems to be audited, logged, and controlled for a variety of purposes. Sensors, network connectivity, and data storage applications are the three key components of an IoT system. Sensors in IoT devices can communicate with the central server directly or through gate way devices to store data. Sensors such as temperature, power, force, humidity, proximity, and others are utilised in many IoT devices. A gateway monitors numerous wireless standard interfaces and can support a variety of technologies and sensors. Gateways connect to the cloud using wireless or cable backbone technologies such as

mobile, DSL and Wi-Fi are available. Figure 1 indicates that the Internet of Things supports both IPv4 and IPv6 protocols. Because of IPv6 support, which has a 128-bit IP address length, there are enough addresses available to meet the growing demand for IoT devices. DTN is one of the unique characteristics of IoT. (Networks that tolerate delays). It handles logic variable delay.

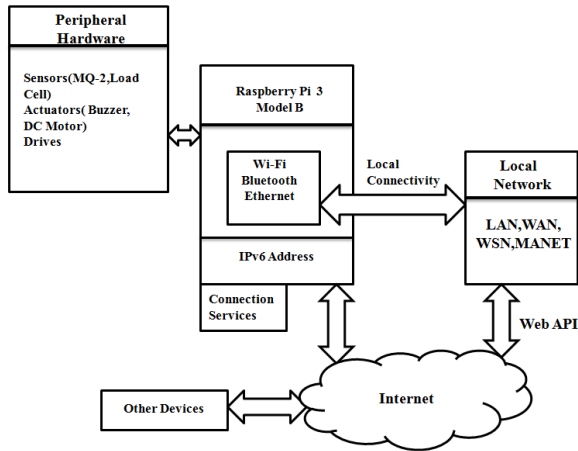

Figure: 1 Simplified IoT Architecture

II. PROPOSED WORK

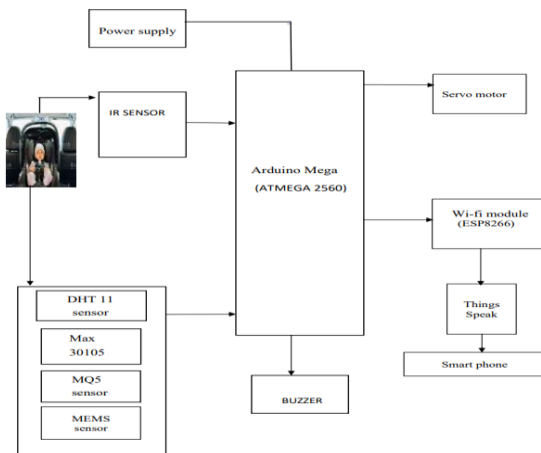

Figure: 2 Proposed Block Diagram

A. ARDUINO MEGA 2560

The ArduinoMega2560 is an ATmega2560-based microcontroller board. It features 54 digital I/O pins (of which 15 are PWM outputs), 16 analogue inputs, 4 UARTs (hardware serial ports), a 16 MHz crystal oscillator, a USB connection, a power jack, an ICSP header, and a reset button. It comes with everything you need to support the microcontroller; simply connect it to a computer through USB or power it using an AC-to-DC adapter or battery to get started.

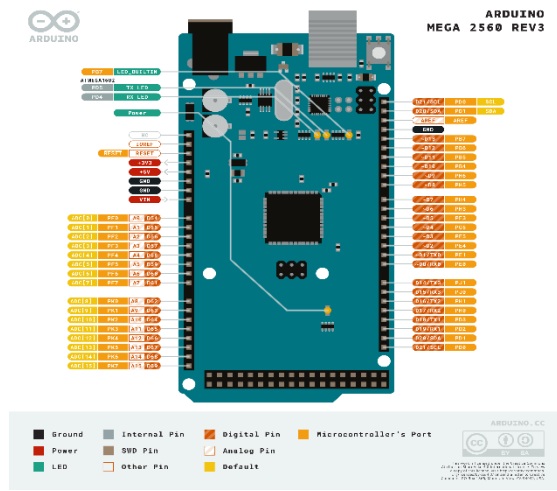

Figure: 3 Arduino Mega 2560

B. ESP8266

The ESP8266 Node MCU CP2102 board contains the ESP8266, a highly integrated chip built for the requirements of a future connected world. It provides an all-in-one Wi-Fi networking solution, allowing it to either host the application or offload all Wi-Fi networking tasks from another application processor.

The ESP8266 features robust on-board processing and storage capabilities, allowing it to be integrated with sensors and other application-specific devices via its GPIOs with minimal development and runtime loading.

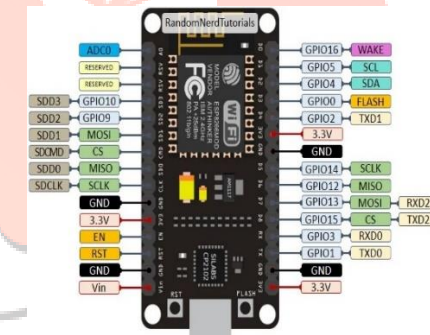

Figure: 4 ESP8266

C. IR SENSOR

The white LED here is an IR LED that serves as the transmitter, and the photodiode next to it serves as the receiver in the IR sensor.



Figure:5 IR sensor

The IR transmitter continuously produces IR light, while the IR receiver continuously looks for reflected light. If the light is reflected back by any object in front of it, the IR receiver receives it. In the case of the IR sensor, the item is detected in this manner.

D. MAX30102 SENSOR

The MAX30102 is a multifunctional sensor that can measure body temperature in addition to heart rate and blood oxygen level. This sensor detects pulse oximetry (SpO2) and heart rate (HR) signals using two LEDs (one infrared and one red), a photodetector, optics, and a low-noise signal processing unit.

The basic idea is to shine a single LED at a time and measure the amount of light reflected back to the sensor. The blood oxygen level and heart rate can be calculated using the reflection.



Figure: 6 Max30102

E. DHT11 SENSOR

The DHT11 is a popular temperature and humidity sensor that includes a dedicated NTC to detect temperature and an 8-bit microprocessor to output temperature and humidity measurements as serial data. The sensor has an accuracy of 1°C and can measure temperature from 0°C to 50°C and humidity from 20% to 90%.

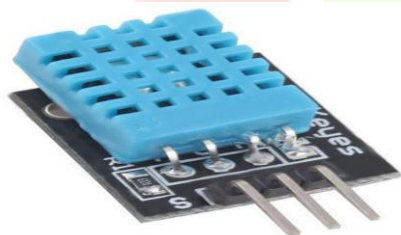

Fig: 7 DHT11 sensor

F. GAS SENSOR (MQ-135)

Ammonia (NH3), Sulphur(S), benzene (C6H6), CO2, and other dangerous gases and smoke can be detected by the MQ-135 Gas sensor. This sensor, like the others in the MQ series, includes a digital and analogue output pin. When the level of these gases in the air exceeds a preset limit, the digital pin swings high. The on-board potentiometer can be used to set this threshold value. The analogue output pin generates an

analogue signal that can be used to estimate the concentration of various gases in the atmosphere.

The MQ135 air quality sensor module operates at 5V and draws around 150mA. It needs to be pre-heated before it can produce reliable findings.



Figure: 8 Gas Sensors (MQ-135)

G. BUZZER

A beeper or buzzer is an electromechanical, piezoelectric, or mechanical type of auditory signaling device. The primary function of this is to transform the audio signal to sound. In general, it is powered by DC voltage and is utilized in timers, alarm devices, printers, alarms, computers, and so on. It can make various sounds such as alert, music, bell, and siren according to the design.

When the IR sensor detects the infant, the buzzer will launch.



Figure:9 Buzzer

III. WORKING OF THE PROJECT

The work in this algorithm of operations consists of the analysis and design of embedded system parts that can be installed in the vehicle to monitor children trapped in the car.

In this proposed system, automation is used to locate the child who has been unknowingly left inside the car when the parents are in an emergency situation as well as to monitor the internal temperature. Front and back IR sensors comprise the car module. If the baby detects something, the microcontroller will activate the buzzer.

The proposed system includes a DHT11 sensor, a Max30105 sensor, a MQ-5 sensor, and a MEMS sensor. The DHT11 sensor is used to determine the temperature and humidity levels inside the vehicle. The Max 30105 sensor is attached to the baby's finger and can detect the baby's

temperature, heart rate, and oxygen level. If the baby's oxygen levels fall below 30 to 70, the microcontroller will sound an alarm using a buzzer.

It also includes a temperature sensor, which monitors the temperature inside the vehicle when it is stopped. When the car is turned off and the child is found alone, the IR sensor inside the car detects motion. If the temperature rises above a certain level, the car window will open automatically to allow for temperature adjustment. To open and close the door, use the remote control.

The MQ 135 gas sensor detects gases released within the vehicle. Using the ESP8266 Wi-Fi module, all sensor values are uploaded to Thing Speak. Using the sensors, we can monitor the baby's condition inside the car. The system also includes a control mechanism. If toxic gases are released or the baby's heart rate or temperature drops, we can use the wireless remote to control the glasses.

#### IV. INSTALLATION

Front and rear IR sensors are fitted in the car cabin. The IR sensor detects whether or not the infant is present in the automobile. The system's cost is incredibly minimal because it only contains one sensor. The kit's connection and view are depicted in the figure.

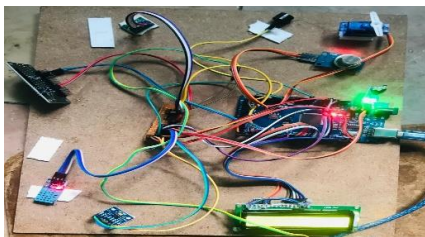
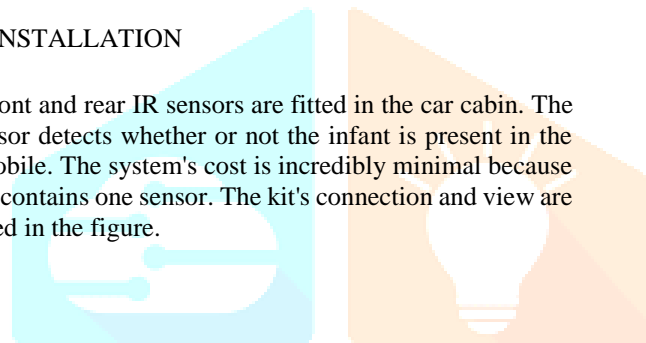

Figure 10: kit

#### V. Sensor values uploaded to ThingSpeak



Figure: 11 spo2 value of children

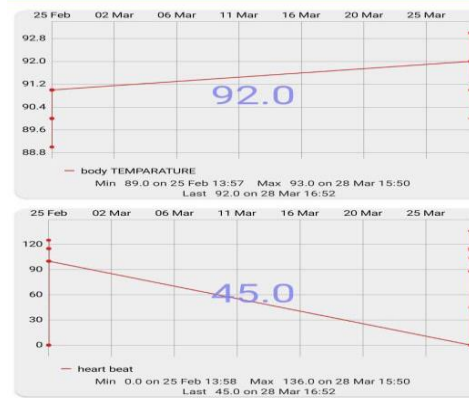

Figure: 12 Heart beat and body temperature of Baby

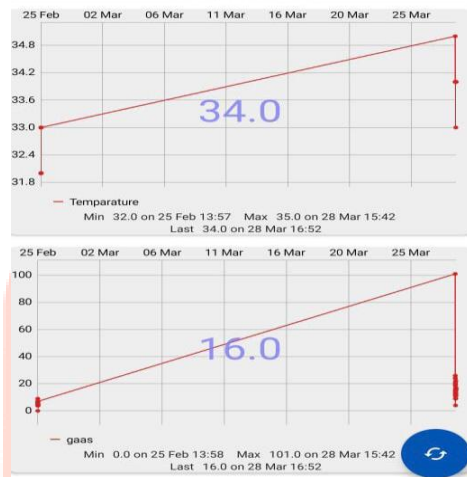

Figure: 13 Temperature and gas value inside the Car cabin

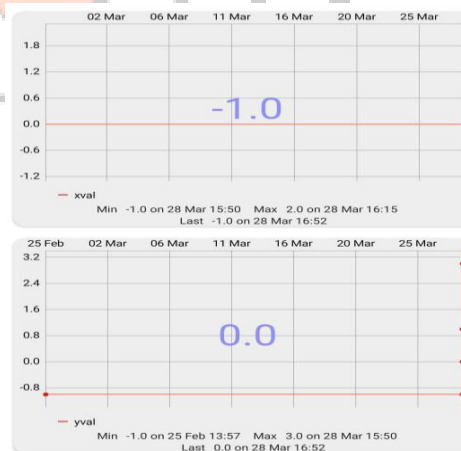

Figure : 14 MEMS value

#### VI. CONCLUSION

During system testing, if IR Motion Senses identifies organisms, an alert system can be initiated. Using the Wi-Fi module, all sensor values are uploaded to the Thing Talk. The technology includes a servo motor that can control the car glasses.

## VII. FUTURE SCOPE

Currently, no such equipment is fitted in the vehicle. It can be quite handy in detecting if a child or pet is trapped inside the automobile. It can be implemented in conjunction with the central locking system in a vehicle.

The installation fee is really minimal. We can boost the system's efficiency by adding more high-accuracy sensors.

If we install this device inside the automobile, we can leave the children inside knowingly because we can check the baby's health indicators.

In the future, it may be possible to improve the system's performance in order to improve the effect of identifying a youngster or a pet and saving from an undesired event.

## REFERENCES

- [1] Shirkande, S., S. Survase, and T. Vitekari, *Design of Sensors based Hyperthermia Car Alert Surveillance System using GSM*. International Journal of Advance Research, Ideas and Innovations in Technology, 2018. 4(2).
- [2] Hazizan, A., N.M. Lazam, and N. Hassan. *Development of Child Safety Car Alert System Using Arduino and GSM Module*. in *IOP Conference Series: Materials Science and Engineering*. 2020. IOP Publishing.
- [3] Lubis, A.M., et al., *Smart Dust Bin With Automatic Lid and Buzzer Alarm*. Journal of Electrical And Electronics Engineering, 2020. 2(2): p. 50-53.
- [4] Ismail, R., Z. Omar, and S. Suaibun. *Obstacle-avoiding robot with IR and PIR motion sensors*. in *IOP Conference Series: Materials Science and Engineering*. 2016.

