



INTERNATIONAL JOURNAL OF CREATIVE RESEARCH THOUGHTS (IJCRT)

An International Open Access, Peer-reviewed, Refereed Journal

Enhancing Database Performance Using SAP S/4HANA

*Pooja Saxena **Dr. Gundeep Tanwar

*(Student of Master of Technology in Computer Science & Engineering, Rao Pahlad Singh College of Engineering & Technology, Balana(Mahendargarh)

** (Assistant Professor in Department of Computer Science & Engineering, Rao Pahlad Singh College of Engineering & Technology, Balana (Mahendragarh)

Abstract:

In today's world, managing large businesses can be very difficult due to the large amount of information. SAP has become one of the largest Data management tools used to manage data for all kind of businesses. When there is big data for any organization, to manage it through third party databases – Oracle or MYSQL, becomes very difficult. It will decrease the performance of system for fetching data from database. In this research paper, implemented a segmentation approach using HANA database for fast access to get the count of records matching a particular pattern (Computation of Complex Reports). This process will make the system more efficient while processing data and performance of system will be increased.

The core idea of SAP HANA database is to integrate business and analytical work in a continuous direction. The main feature of SAP HANA is to use of an in – memory database server, which increases the speed and storage of data. Among other things, it can perform advanced analysis (prediction prediction, spatial data processing, paper analysis, paper search, flow analytics, and graphical data processing, etc.) and includes ETL features with application server.

Keywords — Database Management System (DBMS), SAP High Performance Analytics Appliance, HANA Deployment, Segmentation, Structured Query Language (SQL).

I. INTRODUCTION

Today's Business always want to get very fast access of data and fast growth in market. Dynamic access of data makes system fast in real time world.

SAP S/4HANA one of the SAP's ERP Platform for every kind of businesses like small business or large business. HANA is an ERP Software Package with the main aim to cover all Day-To-Day Processes of an Enterprise (For Instance, Order-To-Cash, Procure-To-Pay, Plan-To-Product, and Request-To-Service) with Core Capabilities.

SAP S/4HANA is one of the SAP's Biggest Update to its ERP strategy and platform in over two decades. SAP ECC based Businesses are using Third-Party Database systems Like – ORACLE, Microsoft and IBM. But SAP HANA implemented

systems have its own HANA database which is implemented through **In-Memory** build Strategy.

SAP HANA implementation would replaces the traditional relational databases through SAP applications. The SAP Net Weaver Business Warehouse (SAP Net Weaver BW) component, which is a proven enterprise data warehouse solution, is the very first application where SAP customers can migrate from their existing database to an SAP HANA database.[1]

II. SAP

SAP become one of the largest data warehousing tool as well as business Processing software in today's marketplace. SAP provides the best ERP (enterprise resource and planning) solutions and services. It provides the modern QuickStart approach to implement small, medium or large

businesses. It helps to make businesses implementation easy, cost-effective and fast accessible. If any Business is looking to grow and transform in today's competitive market, SAP provides the best solution for it. ERP Management Software provides most powerful tool that helps you do this more efficiently. The Software which is available, that can vary widely in usability and its functionality.

Few Basic Functions are *Finance and Accounting, Human Resources Management and Customer Relationships Management*. [2]

In CRM – Marketing includes Campaign management, Lead Management, Case Management Etc. ERP Includes - Business Intelligence (BI), Sales Force Automation (SFA), E-commerce and Automated Marketing. Any kind of organization, Large or Small and regardless of its industry can maintain data processing through ERP. [3]

III. SAP HANA DATABASE

SAP launched S/4HANA database in February 2015 with much fanfare, so much so that SAP CEO Bill McDermott declared S/4HANA the “biggest launch in 23 years, if not in the entire history of the company.”¹ Surprisingly, SAP revealed few details about what S/4HANA could actually do.

S/4 Hana is a SAP's ERP platform. It has its own In-Memory Hana Database. Before S/4 Hana, the previous version of SAP is not dependent on Database and uses third party database systems like DB2, Oracle Database system, MS SQL Database etc. [4]

Initially, SAP S/4HANA was released as a Financial Solution for Next-Generation. The Advantage of SAP HANA Library is that it is build into the database, it full fill the need to migrate huge amount of data from outside system or use third party big data systems . The SAP HANA Predictive Analytics Library (PAL) has capability to analyse regression, time series and social networks. A best example is the material forecast of production which is based on the demand. [5]

IV. SAP HANA OVERVIEW

SAP HANA is an In-memory database platform which can be established or deployed on Premise or on Demand. Basically, it is an innovative in-memory database management system. SAP HANA make

V. DEPLOYMENT OPTIONS FOR SAP S/4HANA

Multiple options exist through which HANA can be Implemented or deployed.

On-Premise

An SAP S/4HANA on-premises deployment consists of Traditional in-house IT Infrastructure

full use of capabilities of current Hardware to enhance application performance, reduce cost of ownership and also enables some new scenarios and applications that were not previously possible. [6]

AS a Developer, the key aspect is to minimize the data movements. In SAP HANA used HANA database (in-memory database), can perform direct operation on data in memory next to the CPUs, application will perform much better through it. This is the Key to development on the SAP HANA data Processing platform. [7]

Traditional Database Architecture

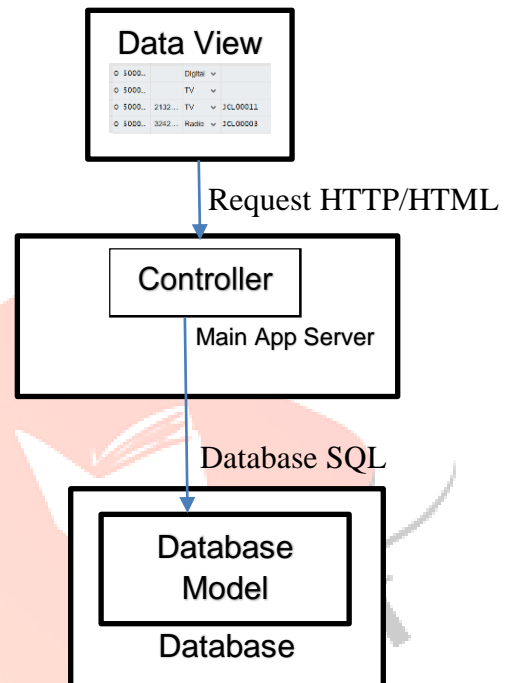

Fig.1.1 Traditional way of Application Services

SAP HANA Database Architecture

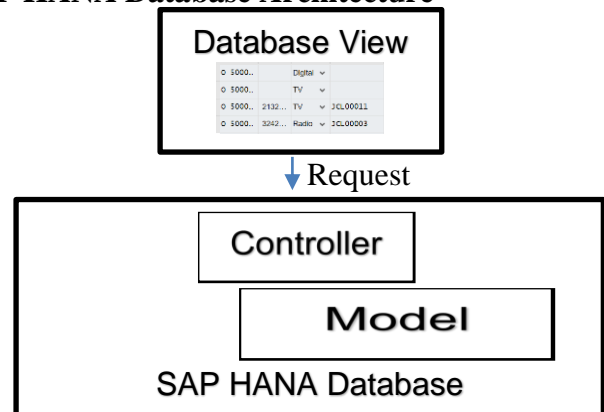

Fig. 1.2 SAP HANA Database Application Services

models. It describes an instance of SAP S/4HANA which is physically hosted on customer Resources.

Cloud

There can be multiple cloud options for SAP S/4HANA Deployment which includes the external cloud integration facility.

- **SAP S/4HANA Cloud** – This deployment provides SAP S/4HANA functionality for establishing a customer Instance of the solution on a partitioned cloud server alongside other customers. The Functional scope is limited here due to standardized setup.
- **Private Cloud** – This kind of deployment provides SAP S/4HANA Functionality without the need for the customer to maintain the technical backend. It is best for companies running SAP ERP.[8]

Hybrid

A Hybrid server model gives the opportunity to pick what works for them and combine it into an ad-hoc solution to full-fill their demand.

For example, an inhouse server can be suitable for companies that do not want to rely on the internet to hold their secure data. but to give users a high degree of uptime, cloud can be incorporated. So, in this case the companies priority may be to select hybrid database strategy for their maintenance.[9]

VI. ENHANCEMENT OF DATABASE PERFORMANCE USING HANA

Database performance increased by using HANA Database which means using HANA database fast access can be done. One of another option to increase performance is using Segmentation approach with HANA. Segmentation is the way to divide marketplace into parts or segments which are definable, accessible, actionable and profitable. We can say, A company can find it impossible to target the entire market, due to time, cost and effort restrictions. There needs to have an accurate segment – a mass of people who can be identified and targeted with reasonable effort, cost and time. Segmentation is flexible based on the characteristics that can be created or customized depending on the unique business requirements. you can add multiple characteristics if possible. for any of the characteristics, the blank value can be made as an acceptable input.[10]

Example, Segmentation process for An Vehicle Manufacturing Organization, where finding the count of records which have been purchased for a particular market and then finding the count of recording for different vehicle type owners.

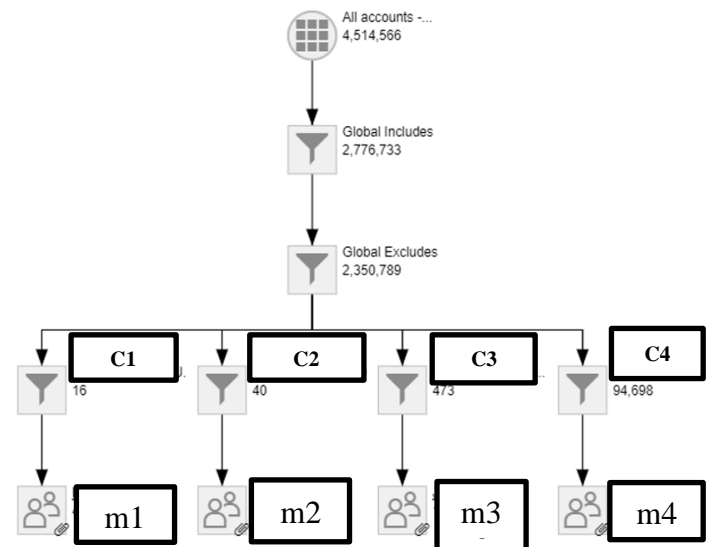

Fig. 1.4 HANA Segmentation

In Fig. 1.4, Graphical representation defined for HANA Segmentation. Take a small instance of any Enterprise provides global services for vehicle manufacturing. For each of the new customer an account will be created. Finally in above Fig. 1.4, Records counted which have Vehicle Colors as C1 , C2 , C3 , and C4 through segmentation process.

There exists multiple models of same color , again can filter it on basis of model as above for m1 , m2 , m3 , m4 . if want to find the count of accounts on basis of any conditions, it can be done through filtering in segmentation process as mentioned in fig. 1.4. Here segment “Global Includes” have been filtered on basis of few conditions that have been implemented through **AND/OR Strategy**. Similarly for each segment filtration have been applied.

Hence, Segmentation Process helps for fast accessing of count of records for a particular category type. Segmentation process used HANA Database which is In-memory set up.

VII. IMPLEMENTATION FOR FAST ACCESS

First of all, There need to store all records which are present in database into HANA Database. To find the count of records on basis of few conditions that can be applied here as shown in fig. 1.5 & Fig. 1.6.

The screenshot shows a 'Filter Details' window. Under 'Description', it says 'Global Excludes'. The 'Exclude' checkbox is checked. Below, the 'Attribute List' is 'Global - Customer Brand Relationships'. A dropdown menu is open, showing 'VIP Flag' selected, with a sub-menu showing 'X (Equal To 'X')'. There is an 'Add Filter' button on the right.

Fig. 1.5 Filtering

Fig. 1.5 defines the filtering of “Global Excludes”, it means in global excludes segment, count of all records excluded which have VIP Flag set. Means all those accounts count displayed which have not set VIP Flag value yet in database.

All Accounts have been fetched which have VIP flag set from a huge number of records.

Fig. 1.6 AND/OR Strategy

Similarly, “Global Includes” can be filtered like as shown in fig.1.6. Conditions,

```

('YSVR' OR
 ('51' OR '52' OR '50')
 OR
 'JAG').
  
```

VIII. FUTURE SCOPE

- 1. Flexible** – there is no way to migrate back to RDBMS if once HANA database have been implemented.
- 2. HANA Helps in a Big memory for CACHE** Data in the database and it always responsible for very fast Processing. But due to it the Budget also increases.
- 3. The main prospect of HANA** is to give the business data to the users as fast as possible. Working on HANA is much more efficient than SAP ERP.[12]

IX. CONCLUSIONS

Through this Paper, we can conclude that SAP S/4 HANA is the future of database because it takes much lesser time for processing of data by any other database . It gives a complete report of data in very short period of time which is helpful for the enterprise to make strategy for future enhancement. Recently most of the enterprises have managed there database into SAP ERP and now enhancing this into HANA Database. It became easy for those organisations to use either On-Premises HANA Database or Private Cloud HANA Database.[15]

ACKNOWLEDGMENT

It is a matter of great pleasure for me to submit this report on the Research Paper entitled “**Enhancing Database Performance Using SAP S/4HANA**”, as a part of curriculum for the award of “Master of Technology” in Computer Science & Engineering, Rao Pahlad Singh College of Engineering & Technology, Balana (Mahendragarh). I would like to express my sincere gratitude to the faculty of Computer Science & Engineering

Department, Rao Pahlad Singh College of Engineering & Technology, Balana (Mahendragarh) for the constant encouragement, expert advice, guidance, devotion and timely suggestions which helped me at every stage of this work. I would also like to thank to all my family members and friends who have helped me in one way or another.

REFERENCES

- [1] Febrice Devaux. 2019. True Processing in Memory with DRAM accelerator. Hot Chips 31 (2019).
- [5] Boncheol Gu, Andre S. Yoon, Duck-Ho Bae, Insoon Jo, Jinyoung Lee, and etc. 2016. Biscuit: A Framework for Near-data Processing of Big Data Workloads. In Proceedings of the 43rd International Symposium on Computer Architecture (ISCA '16). 153–165
- [2] Chetan Khemch and Bhojwani, Pradip S. Ingle. “SAP HANA High Performance Analytical Appliance” - 2019 JETIR April 2019, Volume 6, Issue 4 (JETIR),
- [3] Pedro L. B. Maschio - Distinguished Analyst – “Trends and Outlook: Cloud Adoption for SAP S/4HANA” - Thought Leadership Paper | August 2021.
- [4] SAP S/4HANA- From Wikipedia- https://en.wikipedia.org/wiki/SAP_S/4HANA
- [5] Donghun Lee†, Minseon Ahn†, Jungmin Kim†, Kangwoo Choi†, Oliver Rebolz† - “Optimizing Data Movement with Near-Memory Acceleration of In-memory DBMS”.
- [6] Stephan Kessler, Jens Hoff SAP SE Walldorf, Germany & Stephan Kessler, Jens Hoff SAP SE Walldorf, Germany – “SAP HANA goes private – From Privacy Research to Privacy Aware Enterprise Analytics”
- [7] SAP. SAP HANA Modeling Guide. <https://help.sap.com/viewer/e8e6c8142e60469bb401de5fdb6f7c00/2.0.03/enUS/a9ab474a16d34e56bd72572b9a598216.html>.
- [8] CNIL. Data Protection around the World - <https://www.cnil.fr/en/data-protection-around-the-world>.
- [9] Amazon Web Services. Amazon Aurora Serverless, 2020. <https://aws.amazon.com/rds/aurora/serverless/>, accessed 2020-11-10
- [10] ISG Provider Lens™ | Quadrant Report July 2021- “SAP HANA Ecosystem Services”- Quadrant Report -U.S. 2021
- [11] Färber, Franz, Norman May, Wolfgang Lehner, Philipp Große, Ingo Müller, HannesRauhe, and Jonathan Dees. "The SAP HANA Database--An

design summary." IEEE Data Eng. Bull. 35, no. 1 (2012): 28-33.

[12] Plattner, Hasso. "The impact of columnar in-memory databases on enterprise systems: implications of eliminating transaction-maintained aggregates." Proceedings of the VLDB Endowment 7, no. 13 (2014): 1722-1729.

[13] White paper "SAP HANA and SAP S/4HANA – The right steps towards a digital advantage" – FUJITSU,

[14] Wang, J. Blocki, N. Li, and S. Jha. Locally differentially private protocols for frequency estimation. In 26th USENIX Security Symposium, USENIX Security, Vancouver, BC, Canada, August 16-18, pages 729–745, 2017.

[15] Färber, Franz, Sang Kyun Cha, Jürgen Primsch, Christof Bornhövd, Stefan Sigg, and Wolfgang Lehner. "SAP HANA knowledgebase: data management for contemporary business applications." ACM Sigmod Record 40, no. 4 (2012): 45-51.

[16] J. McGlone, P. Palazzari, and J. B. Leclere. 2018. Accelerating Key In-memory Database

Functionality with FPGA Technology. In 2018 International Conference on ReConfigurable Computing and FPGAs (ReConFig). 1–8.

[17] Hasso Plattner. 2014. The Impact of Columnar In-memory Databases on Enterprise Systems: Implications of Eliminating Transaction-maintained Aggregates. Proc. VLDB Endow. 7, 13 (Aug. 2014), 1722–1729.

[18] Thomas Willhalm, Ismail Oukid, Ingo Müller, and Franz Färber. 2013. Vectorizing Database Column Scans with Complex Predicates.

[19] David Sidler, Zsolt István, Muhsen Owaida, and Gustavo Alonso. 2017. Accelerating Pattern Matching Queries in Hybrid CPU-FPGA Architectures. In Proceedings of the 2017 ACM International Conference on Management of Data (SIGMOD '17). 403–415.

[20] Thomas Willhalm, Nicolae Popovici, Yazan Boshmaf, Hasso Plattner, and etc. 2009. SIMD-scan: Ultra Fast In-memory Table Scan Using On-chip Vector Processing Units. Proc. VLDB Endow. 2, 1 (Aug. 2009), 385–394.

