



# Emerging Trends In Iot-Enabled Water Supply Systems

S.ARIVARASAN<sup>1</sup>, N.Chandru<sup>2</sup>, S.Gokul<sup>3</sup> and R.Arun prasath<sup>4</sup>

<sup>1</sup>Associate Professor, Computer Science and Engineering, V.S.B Engineering College, Karur, Tamandu, India

<sup>2</sup> Student, Computer Science and Engineering, V.S.B Engineering College, Karur, Tamandu, India

<sup>3</sup> Student, Computer Science and Engineering, V.S.B Engineering College, Karur, Tamilnadu, India

<sup>4</sup> Student, Computer Science and Engineering, V.S.B Engineering College, Karur, Tamandu, India

## ABSTRACT

According to a recent poll, water has become a major concern due to reduced rain fall and a rise in population in many places. People are suffering as a result of this problem since they do not have enough for their daily requirements. Water cannot be delivered efficiently due to a lack of monitoring; certain portions of the city receive water while others do not; hence, continual monitoring, water supply scheduling, and proper distribution are required. Other issues include excessive usage, tank overflow, pipeline leaks, and interruptions in water delivery. Water is a basic need for every human being. Many times, due to a lack of monitoring, overflow of these overhead tanks can occur, wasting a lot of water. Another issue is that overflow in the pipelines with more pressure can cause pipeline damage, and leakage detection is another issue. All of these issues are caused by a lack of monitoring, manual work, and a lack of man power. Before beginning this project, I conducted a study of Bangalore city to better understand water supply distribution and system challenges. After doing the survey, I discovered that all of the labor is manual and that a better technology is required to ensure appropriate distribution.

This allows the consumer to adjust their water consumption without incurring additional costs. If the consumer consumes too much water, the supplier will cut off the water supply. The fundamental purpose of this project is to ensure that there is no wastage or blockage in the delivery of water to all homes, as well as to create water bills for specific families utilizing IoT platforms. To put this system together, we'll be using Arduino. Water flow sensors and a valve to regulate the water from the tank ultrasonic sensor provides a sequence of electric pulses through which the user's water use, flow rate, can be determined.

**Keywords**—ARDUINO UNO, BLUETOOTH MODULE, DC MOTOR, LCD.

## INTRODUCTION

A water distribution system is made up of several components such as pipelines, valves, pumps, and tanks. The pipeline configuration aids in the conveyance of water from the source to the individual residence. The most significant aspect for a lifetime of projected loading circumstances is the design and operation of a water distribution system. A water distribution system must also be capable of assisting in the event of atypical events such as pipe breakage, mechanical failure of pipes, valves, and control systems, power outages, and erroneous demand estimates. The Internet of Things (IoT) has had a significant influence on today's world. The concept of wirelessly linking everything simplified things. With the sensors created particularly for items, we can link anything. The sustainability of accessible water resources is currently a severe concern in many parts of the world. This issue is inextricably linked to insufficient water use and integrated water mismanagement. Water is extensively used in agriculture, industry, and household use. Water monitoring is an essential restriction for several human uses. Unnecessary water waste can be reduced by

levying small fees that are affordable to the poor. At the moment, just one bill is generated for the whole building, which is distributed equitably among the building's users. As a result, persons who use a great amount of water are equivalent to those who use a little amount of water, and they pay additional money for water consumption.

As a result, most bodies of water and groundwater resources are over utilized, resulting in water shortage. It is critical that we understand how much water we have access to. Water resource management and distribution is a critical problem since it entails methods to safeguard water sources from contamination and overuse. Water supply, quality, and management are the most pressing issues in India. In developed metropolitan areas, water demand outweighs supply, resulting in lower water availability; consequently, appropriate management is required.

Manpower is required to transport water to various locations. The volume of water distributed and the water bills are not checked in such circumstances. Industries. This is an intelligent system that employs ultrasonic sensors to create a series of electric pulses that may be used to determine the quantity of water used by the user, the flow rate, and the amount of water delivered. The suggested system continually monitors the water level in the main tank and turns the motors ON/OFF based on the level. A control valve and an ultrasonic sensor govern the flow of water through the pipe. This procedure may be carried out using an IoT platform.

## LITERATURE SURVEY

[1] The paper uses historical analysis to focus on the water systems' successes and vulnerability issues, and to explain how management has been able to respond to different pressures over time. Each water system has been exposed to an array of pressures, including technological changes, socioeconomic and demographic changes, all of which have influenced the functioning of their water governance regimes.

[2] The system design is consisted of four main components such as Arduino UNO microcontroller and Bluetooth module, current and water flow sensors, RGB LED, and alarm buzzer. Current and water flow sensors will measure the current and water flow driven in installation. Three different situations have been applied to test the device performance.

[3] The paper proposes a system design which uses pH sensor, turbidity sensor and conductivity sensor for determine its quality of the water. The system uses the solenoid valve for regulating the pipeline for supplying the potable water

[4] Smart cities have successfully applied the Internet of Things (IoT) technology in many sectors. Moreover, Complex Event Processing (CEP) can analyze and process large data sets produced by IoT sensors in real-time.

[5] This study first discusses the architecture and various components of IoT based water management system in detail followed by in-depth survey of all existing IoT based water management systems. Various measurement parameters such as water level, pH level, turbidity, salinity, etc.

[6] The provisions of the European law have defined "Smart Metering" as a tool for remote meter readings and management of energy networks. Currently, after years of research and many real-life applications, it is one of the most popular solutions that defines friendly and modern cities.

[7] The available water is not used in proper amount and hence many times the water is wasted. It is also observed that, the drainage water is mixing with the sources of clean water and contaminating it. Due to improper drainage system the present clean water is also wasted.

[8] This paper experiences the speed control of a direct current servomotor, type SM-S2309S, with the help of the Arduino UNO platform, which is the simplest solution for the development of electronic applications. The study experiences also speed and step control of a stepper motor, type 28BYJ-48, with the Arduino UNO platform.

[9] Nowadays there are various implementation is available to determine the water quality but there is a lack in real time challenge to maintain the quality of supplying the water to the houses. So here the paper proposes a system design which uses pH sensor, turbidity sensor and conductivity sensor for determine its quality of the water.

[10] Both the status and progress of SWM implementation are quite different among countries, although governments across the world have been applying water policies responding to water scarcity, population growth, and water demand management. However, the absence of strong water policies and political support for SWM implementation resulted in the slow and retarded spread of SWM implementation.

## PROPOSED METHOD

Wastage of water in the process of manually operated water pump, human error associated with manually operated system, incorrect bill creation, delay in bill availability, and delay in payment process are all issues that have led to the development of a "IOT based Automatic Water Billing (AWB)" system. A low-cost water meter is proposed in the AWB system, which measures the flow rate of water passing through the supply pipe of a specific user and generates invoices based on that user's water use. This allows the consumer to adjust their water consumption without incurring additional costs. If the consumer consumes too much water, the supplier will cut off the water supply.

A water billing system based on IoT is presented. This system is made up of an ATMEGA328P microcontroller that is linked to an ultrasonic sensor, a water motor, and a flow sensor. The system measures the water level in the tank using an ultrasonic sensor. Each supply pipe has a Flow Sensor that regulates the flow of water to each user. The water is delivered to the dwellings from the main tank. When an ultrasonic sensor detects an empty water tank in a residence, the controller sends a signal to the solenoid valve, which opens to allow for water delivery. Only when the water exit valve is closed is the water inlet valve opened, and vice versa. The system collects data and updates payment details based on IOT water use.

## SOFTWARE DESCRIPTION

### ARDUINO IDE

The term "IDE" refers to an official program introduced by Arduino.cc that is mostly used for editing, compiling, and uploading code to the Arduino Device. Virtually all Arduino modules are compatible with this open-source software, which is simple to install and begin compiling code on the fly. In this tutorial, we'll go through the software, how to install it, and how to get it ready for programming apps with Arduino modules. The Arduino IDE is an open-source program used primarily for developing and compiling code for the Arduino Module. It is an official Arduino program, making code compilation so simple that even a layperson with no prior technical expertise may start learning. It is easily available for operating systems such as MAC, Windows, and Linux and operates on the Java Platform, which has built-in functions and commands for debugging, editing, and compiling code in the environment. A variety of Arduino modules are available, including the Arduino Uno, Mega, Leonardo, and Micro, among others. Each of them has a microcontroller on the board that is programmed and takes data in the form of code. On the board of each of them is a microcontroller that has been programmed and takes input in the form of code. The primary code, also known as a sketch, written on the IDE platform will eventually generate a Hex File, which is then copied and uploaded into the board's controller. The IDE environment consists primarily of two fundamental components: the Editor and the Compiler, the former of which is used for creating the needed code and the latter for compiling and uploading the code into the specified Arduino Module. This environment supports both the C and C++ programming languages.

### IDE Specifications:

The IDE environment is divided into three sections:

1. Menu Bar
2. Text Editor
3. Output Pane



## PROTEUS

Proteus is a simulation and design software tool for electrical and electronic circuit design created by Lab center Electronics. It also has a 2D CAD drawing capability. The tagline "From concept to completion" is appropriate. It is a software package that includes schematic, simulation, and PCB design. The ISIS program is used to create schematics and model circuits in real time. The simulation enables for human interaction during run time, resulting in real-time simulation. ARES is used to design PCBs. It provides the capability of seeing output in 3D perspective of the created PCB as well as components. The product's designer can also create 2D drawings.

ARES provides surface mount and through-hole PCB design with up to 14 inner layers. It contains the imprints of several types of discrete components, including ICs, transistors, headers, connections, and others. The PCB Designer has access to both automatic and manual routing methods. It is possible to convert the ISIS schematic straight to ARES.

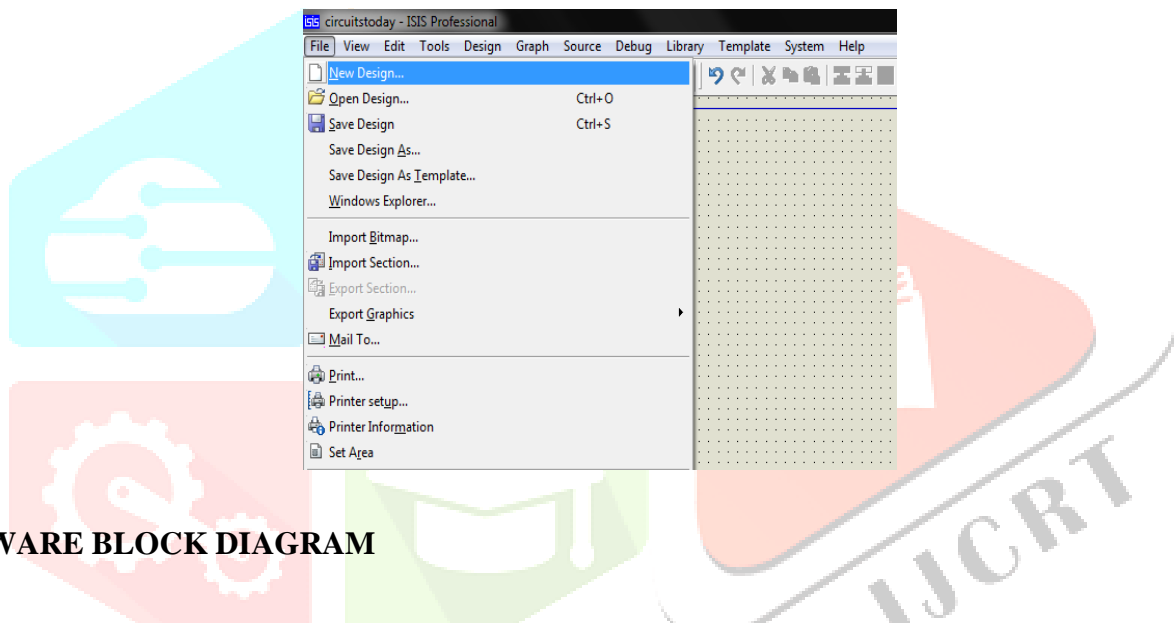

## HARDWARE BLOCK DIAGRAM

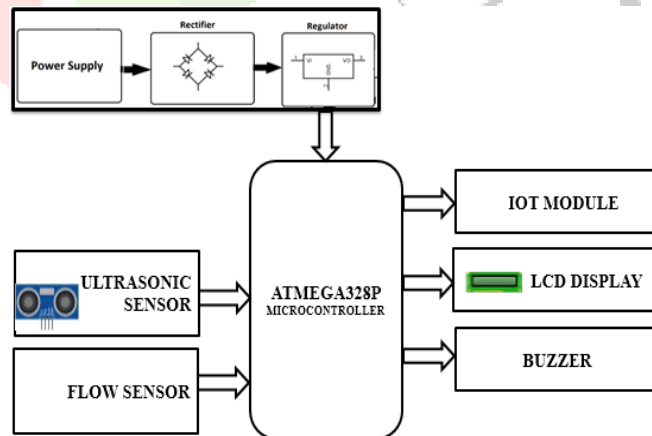

## HARDWARE BLOCK DIAGRAM

## HARDWARE EXPLANATION

This project aims to distribute water to every person. If the water level is high in some places in my project, it will divide the water to the wanted places.

The ultrasonic sensor senses the water level and displays it on the LCD, and also sends a message to the IOT. If the water is high, it will divide through the flow sensor and indicate the LCD, and a beep sound will be on to alert everyone. This message is also sent to the higher efficient.

## METHODS

### MODULE LIST

- POWER SUPPLY
- ARDUINO UNO
- ULTRASONIC SENSOR
- FLOW SENSOR
- NODEMCU
- LCD
- BUZZER

## MODULE DESCRIPTION

### POWER SUPPLY

The source is where the power comes from. The electrical source is usually an outlet, a battery, or a generator. The power supply converts the electricity from the source into the proper voltage and format. Because there are several alternatives, the specific power supply function is determined by whether it needs to control energy or convert power.

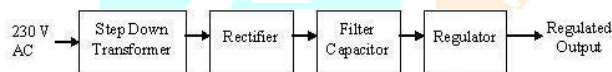

### TRANSFORMER

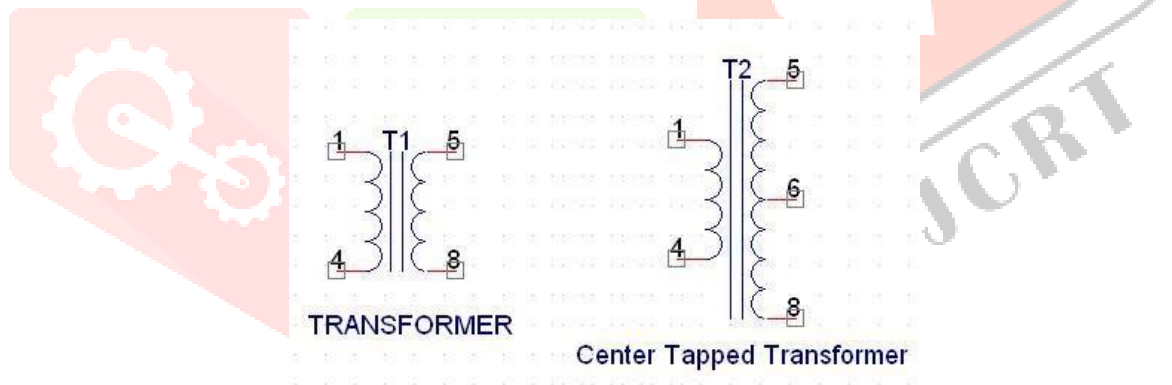

A transformer is made up of two coils, commonly known as "WINDINGS," namely the PRIMARY and SECONDARY. They are connected via inductively coupled electrical conductors, also known as CORE. A change in main current generates a change in the magnetic field in the core, which induces an alternating voltage in the secondary coil. When a load is connected to the secondary, an alternating current flow through the load. In an ideal situation, all of the energy from the main circuit is transmitted to the secondary circuit via the magnetic field. So  $P_{primary} = P_{secondary}$   $I_p/V_p = I_s/V_s$  The secondary voltage of a transformer is determined by the number of turns in both the primary and secondary windings.  $V_s/V_p = N_s/N_p$ .

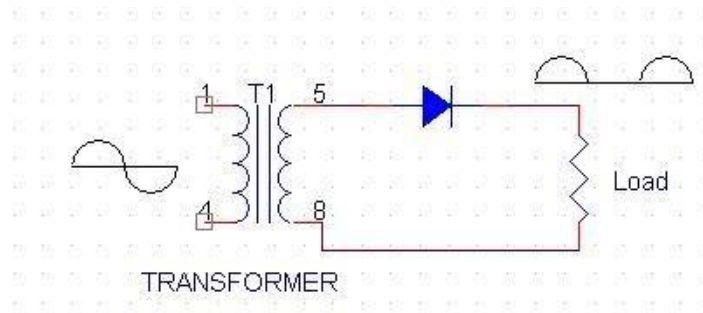
**RECTIFIER: -**

A rectifier is a device that transforms an alternating current signal into a direct current signal. We utilize a diode for rectification. A diode is a device that enables current to flow only in one direction, namely when the anode of the diode is positive with respect to the cathode, also known as the forward biased state, and prevents current in the reversed biased situation. Rectifiers are categorized into the following types: Half-wave, full-wave, and bridge rectifiers are examples of rectifiers.

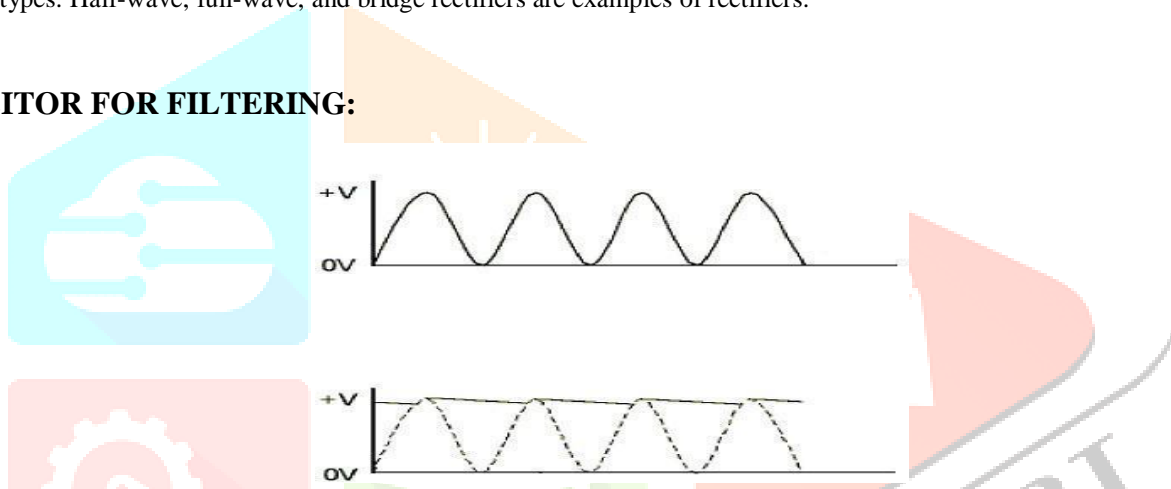
**CAPACITOR FOR FILTERING:**

Although both half wave and full wave rectifiers provide DC output, neither produces a consistent output voltage. Smoothing the waveform received from the rectifier is required for this. This may be done by employing a capacitor at the output of the rectifier this capacitor is also named as "FILTER CAPACITOR" or "SMOOTHING CAPACITOR" or "RESERVOIR CAPACITOR". Even after utilizing this capacitor, some ripple will remain. We connect the Filter Capacitor to the rectifier's output; the capacitor will charge to the peak voltage during each half cycle, then gently discharge its stored energy through the load when the rectified voltage drops to zero, attempting to maintain the voltage as constant as possible. The ripple will reduce when we increase the value of the filter capacitor. But the cost will rise as a result.

The value of the Filter capacitor is determined by the circuit's current consumption, waveform frequency, and acceptable ripple.  $C = \frac{V_r F}{I}$ , where  $V_r$  is the allowed ripple voltage. (Should not exceed 10% of the voltage)  $I$  denotes the current absorbed by the circuit in Amperes.  $F$  denotes the waveform's frequency. A half wave rectifier has one peak in one cycle, resulting in  $F=25\text{hz}$ , whereas a full wave rectifier has two peaks in one cycle, resulting in  $F=100\text{hz}$ . A

**VOLTAGE REGULATOR**

It is a device that transforms a fluctuating input voltage to a constant controlled output voltage. There are two kinds of voltage regulators.

- 1) Regulator of Linear Voltage They are also known as resistive voltage regulators because they dissipate excess electricity as heat.
- 2) Regulators are switched. They control the output voltage by quickly switching the current on and off. Because their output is either ON or OFF, they squander relatively little power and so achieve better efficiency than linear voltage regulators. Yet, because of their switching behavior, they are more complicated and create a lot of noise. Switching regulators are more expensive at low output power levels, but significantly cheaper for larger output wattage levels than linear regulators.

## ARDUINO UNO

The Arduino UNO is a standard Arduino board. UNO means "one" in Italian. The initial release of Arduino Software was labeled as UNO. It was also the first USB board made available by Arduino. It is regarded as a powerful board that is employed in a variety of tasks. The Arduino UNO board was created by Arduino.cc. The Arduino UNO is built on the ATmega328P microprocessor. In comparison to other boards, such as the Arduino Mega, it is simple to use. The board is made up of digital and analog I/O pins, shields, and other circuitry. The Arduino UNO has six analog input pins, fourteen digital pins, a USB connection, a power jack, and an ICSP (In-Circuit Serial Programming) header.

**ATmega328 Microcontroller-** It is an ATmel family single chip microcontroller. It has 8-bit processor code. Memory (SRAM, EEPROM, and Flash), Analog to Digital Converter, SPI serial ports, I/O lines, registers, timer, external and internal interrupts, and an oscillator are all included. **ICSP pin -** The In-Circuit Serial Programming pin allows the user to program the Arduino board's firmware. **Power LED Indicator-** The ON condition of the LED indicates that power is turned on. The LED will not light up if the power is turned off. **Digital I/O pins-** The digital pins have a HIGH or LOW value. Digital pins are those with numbers ranging from D0 to D13. **TX and RX LEDs-** The illumination of these indicates a successful data transfer.

**AREF-** The Analog Reference (AREF) pin is used to send a reference voltage from the external power source to the Arduino UNO board. It is used to include a Reset button in the connection. **USB-** It enables the board to communicate with the computer. It is required for programming the Arduino UNO board. **Crystal Oscillator-** At a frequency of 16MHz, the Crystal oscillator makes the Arduino UNO a powerful board. The voltage regulator transforms the input voltage to 5 volts. **GND** stands for ground pins. The ground pin functions as a zero-voltage pin. The input voltage is denoted by the symbol  $V_{in}$ . **Analog Pins-** Analog pins are those with numbers ranging from A0 to A5. Analog pins' job is to read the analog sensor used in the connection. It also serves as GPIO (General Purpose Input Output) pins.

## ULTRASONIC SENSOR

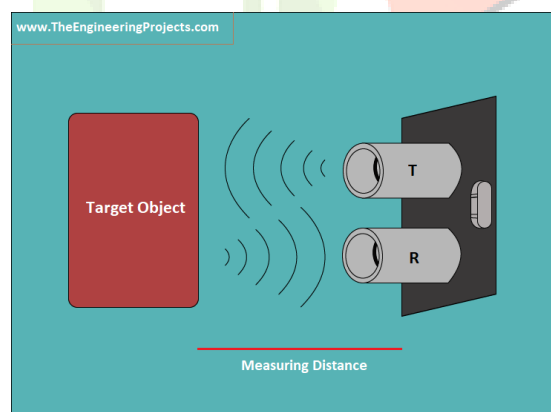

an ultrasonic detecting method used to identify concealed tracks, discontinuities, and water levels in metals, composites, polymers, and ceramics. As ultrasonic sensors employ sound instead of light for sensing, the laws of physics showing the propagation of sound waves through solid materials have been applied for this purpose. This blog will teach us about the ultrasonic sensor's functioning principle and applications. The image above depicts the HC-SR-04 ultrasonic sensor, which includes a transmitter and a receiver. The pin arrangement is as follows:

- VCC - +5 V supply
- TRIG - Sensor trigger input. The microcontroller sends a 10-second trigger pulse to the HC-SR04 ultrasonic module.
- ECHO-Sensor output echo. This pin is read/monitored by the microcontroller in order to identify the obstruction or determine the distance.

GND - Ground Sound is a mechanical wave that travels through a media that can be solid, liquid, or gas. Sound waves can travel across media at different speeds depending on the medium of propagation. Sound waves of a high frequency reflect from boundaries, producing different echo patterns. Ultrasonic Sensor Characteristics 1. Power supply voltage: 5V (DC). 2. The supply current is 15mA. 3. The modulation frequency is 40 hertz. 4. 0 - 5V output (Output high when obstacle detected in range). 5. Maximum beam angle of 15 degrees. 6. Dimensions: 2 cm - 400 cm. Precision: 0.3cm. 8. Positive TTL pulse for communication.



At regular intervals, ultrasonic sensors generate brief, high-frequency sound pulses. They go through the air at the speed of sound. If they impact an object, they are reflected back to the sensor as echo signals, which calculates the distance to the target based on the time between generating the signal and getting the echo. Background interference is effectively suppressed by ultrasonic sensors. Almost any substance that reflects sound, regardless of color, may be detected. Transparent materials or thin foils are no match for an ultrasonic sensor. Microsonic ultrasonic sensors are ideal for target distances ranging from 20 mm to 10 m, and because they record the period of flight, they can provide pinpoint precision. Some of our sensors can even resolve the signal to 0.025 precision.

## FLOW SENSOR



A flow sensor is a device that monitors the flow of a fluid, such as a gas or liquid. Flow sensors use both mechanical and electrical subsystems to sense changes in the physical properties of a fluid and compute its flow. Measuring these physical properties is dependent on the fluid's physical properties. Since gaseous, liquid, and non-Newtonian fluids behave so differently, the methods we employ to quantify their flow must differ as well. Flow sensors are classified into numerous categories. We'll go through two of the most common types here: differential pressure and thermal mass flow sensors. Differential Pressure Type 1 Flow Detectors the Bernoulli equation shows that the velocity of a fluid is directly related to its pressure:  $dp = (\text{density} * \text{velocity}^2) / 2$ .

Differential pressure flow sensors calculate fluid pressure. The sensors monitor pressure at two different velocities while maintaining fluid density. With most differential pressure flow sensors, a single pressure detecting node, such as a pitot tube, stands on the fluid flow path's edge. The fluid is accelerated by a nozzle or a change in orifice diameter, and it is measured at a greater velocity. Once the sensor has determined the pressure differential, we can use the Bernoulli equation to calculate the fluid velocity. Lastly, the fluid velocity may be used to calculate the entire flow through the pipe. To precisely compute the fluid's velocity, various factors must be controlled.

As a result, rather than adapting to an existing pipe, differential pressure-based flow sensors are often assemblies that "interrupt" the piping. The differential pressure approach is used by a variety of sensors, including: Venturi tubes Rotameters Plates with orifices Arrays of pitot tubes the accuracy and system pressure loss of each of these sensors varies. Because of its performance and



adaptability, differential pressure flow sensors are the most prevalent type of flow sensor. 2) Thermoelectric Mass Flow Sensors

Thermal mass flow sensors are commonly employed in gaseous, low-flow, high-accuracy applications such as semiconductor production. They use the thermal characteristics of a fluid to monitor the flow through a system.

A thermal mass flow system can be configured in one of two ways, but both rely on a fluid's ability to absorb thermal energy to determine the quantity of energy in the fluid. Here's a quick rundown of the two options:> Method one: A heating element and a thermal sensing element collaborate to measure the amount of energy absorbed by the fluid as it travels past the heating element and the thermal sensor. The fluid first absorbs the energy from the heating element. The fluid is then measured by the sensor to determine how much energy it has absorbed. Method two: A single heating element operates to maintain a constant temperature. When the fluid absorbs energy, it cools the heating element, necessitating additional energy in the system to keep the temperature stable. We determine mass flow by determining how much energy the heating element expends to keep itself at a constant temperature.

## NODEMCU



NodeMCU is an open-source Lua-based firmware for Espressif's ESP8266 WiFi SOC that employs an on-module flash-based SPIFFS file system. NodeMCU is written in C and is built on the Espressif NON-OS SDK. The firmware was originally created as a companion project to the popular ESP8266-based NodeMCU development modules, but it is now community-supported and may be run on any ESP module.

Construction & Specs 2.5 to 3.3V operating voltage 800 mA is the operating current. On-board voltage regulation of 3.3V 600mA The ESP8266 has two switches: one for reset and one for flashing. The reset button is used to reset the NodeMCU, while the flash button is used to download and flash the firmware. The board has an LED indication that is attached to the D0 pin. The NodeMCU board also has a CP2102 USB to UART module, which converts data from USB to serial, allowing it to be controlled and programmed from a computer. The esp8266 has four power pins: one for input power supply and three for output power supply.

## LCD



Liquid Crystal Display, or LCD in LCD 16\*2, is a display technology that is used in displays for computer monitors, Televisions, smartphones, tablets, and other mobile devices. While LCD and CRT screens have similar appearances, they operate differently. A liquid crystal display contains a backlight that illuminates each pixel that is placed in a rectangular network, as opposed to electrons diffracting at a glass panel. The LCD 16\*2 is a type of electronic display that shows information and messages. As the name implies, it has 16 Columns and 2 Rows, allowing it to show 32 letters (16 x 2), each of which is made up of 5 x 8 (40) Pixel Dots.

Hence the total number of pixels in this LCD may be computed as  $32 \times 40$ , or 1280 pixels. LCD 16X2 specifications The LCD 16X2 specs are detailed further below. This display's working voltage varies from 4.7V to 5.3V. The display bezel is 72 x 25mm. Without a backlight, the operational current is 1mA. The module's PCB dimensions are 80L x 36W x 10H mm, and the LED color for the backlight is green or blue. The number of columns is sixteen. The number of rows is two, and the number of LCD pins is sixteen. 32 characters It operates in both 4-bit and 8-bit modes. Each character has a pixel box of 58 pixels and a font size of 0.125width x 0.200height.

## BUZZER



A buzzer is a device that produces a buzzing or beeping sound when activated. It is commonly used as an alarm or warning signal in various applications, such as in electronic games, timers, doorbells, and security systems. The sound is typically generated by an oscillating circuit that drives a small speaker or piezo element. Buzzer can be either active or passive. An active buzzer has an internal oscillator and generates a tone when a voltage is applied to it. A passive buzzer, on the other hand, requires an external oscillator circuit to produce a tone. Buzzer is a common component used in electronics projects and can be easily controlled by a microcontroller or other digital circuitry.

Because the self-excited buzzer is powered by DC voltage, it does not require an AC signal to operate. To make the buzzer sound, it merely has to output the driving level at the drive port and amplify the driving current through the triode. It's quite easy, and the self-excited buzzer isn't covered here. This document solely discusses the other excited buzzer, which requires a 1/2-D square wave signal to operate. The individually excited buzzer may be driven in two ways: directly via the PWM output port, or indirectly using the I/O timing flip level to construct the driving waveform.

## CONCLUSION

This proposed effort is a crucial prerequisite for individuals in the current world to tackle water-related difficulties. By adding automatic theft prevention, reliable data monitoring from the central server assists habitats in receiving appropriate water. Water theft in government pipes may be completely eliminated by completing the recommended study effort, and habitats can meet their increased water requirements by purchasing. So that acquiring water for those in need is not a difficult task. This suggested work is not only suited for water delivery, but it may also be used in the future to distribute liquid petroleum gas and other fuels via pipes. An IoT-based water distribution system can significantly improve the efficiency and reliability of water distribution networks. By integrating smart sensors, data analytics, and automated control systems, the system can detect and prevent leaks, monitor water quality, optimize energy consumption, and reduce operational costs. Moreover, the system can provide real-time insights into the performance of the network, enabling operators to make informed decisions and take proactive measures to prevent potential failures. However, the implementation of an IoT-based water distribution system requires significant investment in hardware, software, and skilled personnel. Therefore, careful planning, design, and maintenance are essential to ensure the long-term sustainability and effectiveness of the system. Overall, an IoT-based water distribution system can bring significant benefits to the

water industry, such as improved water conservation, enhanced customer satisfaction, and better environmental sustainability.

## ADVANTAGES

- Efficient water distribution
- Reduces water wastage
- Improved maintenance
- Cost-effective
- Sustainability
- Customer satisfaction

## DISADVANTAGES

- High initial cost
- Technical difficulties
- Privacy and security concerns
- Limited coverage
- Data accuracy
- Maintenance and repair costs
- Dependence on technology

## APPLICATION

- Smart Metering
- Leak Detection
- Water Quality Monitoring
- Predictive Maintenance
- Real-Time Monitoring
- Remote
- Water Conservation

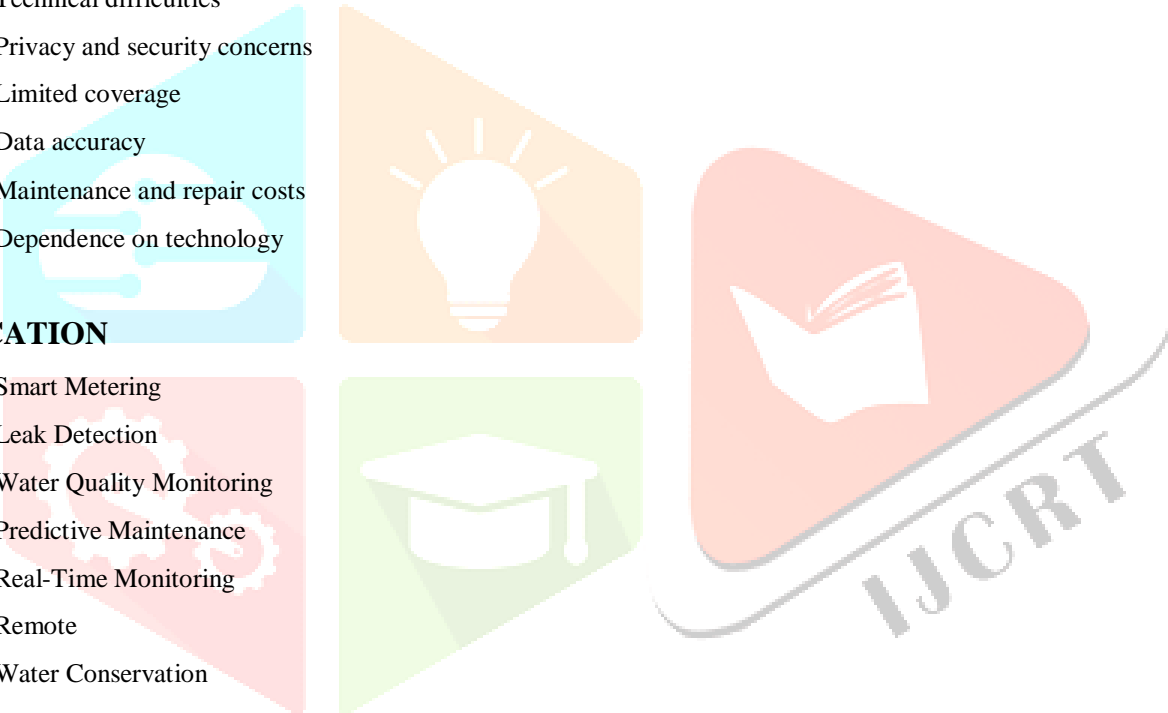

## FUTURE WORKS

- Integration with smart city infrastructure: In the future, IoT-based water distribution systems can be integrated with other smart city infrastructure like traffic management, waste management, and emergency response systems to create a more comprehensive smart city ecosystem.
- Predictive maintenance: The use of machine learning algorithms to predict potential issues in the water distribution system can help prevent breakdowns and reduce maintenance costs.
- Real-time monitoring and analytics: Real-time monitoring and analytics of the water distribution system can help identify leaks, reduce water loss, and optimize the system's performance. Integration with weather forecasting: Integrating weather forecasting data into the water distribution system can help predict demand and optimize the system's
- Performance accordingly. Integration with smart home technology: IoT-based water distribution systems can be integrated with smart home technology to allow homeowners to monitor and control their water usage and detect leaks in real-time.
- Water quality monitoring: In the future, IoT-based water distribution systems can be equipped with sensors to monitor water quality in real-time and provide alerts in case of contamination.

Water conservation initiatives: IoT-based water distribution systems can help encourage water conservation by providing real-time feedback on water usage and implementing water-saving measures like low-flow fixtures and rainwater harvesting. Use of renewable energy sources: The use of renewable energy sources like solar power to power IoT-based water distribution systems can reduce the system's carbon footprint and make it more sustainable

## REFERENCES

- [1]. Sapna Suryawans B. Marimuthu, K. Chithra, (2017), 'Ultrasonic water level indicator and controller using AVR microcontroller', International Conference on Information Communication and Embedded Systems, Vol.3, No.5, pp. 25-44. 10.
- [2]. Rohini Bhuse, MeghaGite, Dhanashri Hande, (2017), 'Waste Management System Based on IoT', Matoshri Collage of Engineering & Reasearch Centre, Vol.5, No.2, pp. 1835-1837.
- [3]. Sagar Khole, Tushar Kople and A.P More, "Automated Drinking water supply system and theft identification using Embedded technology", International Journal of Innovative Research in Computer and Communication Engineering, Vol.3, 2015, pp.1-6. 7.
- [4]. Ahmad T. Jaiad, and Hamzah Sabr Ghayyib, "Controlling and Monitoring of Automation of Water Supply system based on IOT with theft identification", International journal of research – GRANTHAALAYAH, Vol.5, No.5, 2017.
- [5]. Libelium, "Smart water sensors to monitor water quality in rivers, lakes and the sea", Retrieved March 26, 2018, <http://www.libelium.com/smart-water-sensors-to-monitor-waterquality-in-rivers-lakes-and-the-sea>.
- [6]. F. U. Qureshi, A. Muhtaroglu, & K. Tuncay, "Near-Optimal Design of Scalable Energy Harvester for Underwater Pipeline Monitoring Applications with Consideration of Impact to Pipeline Performance". IEEE Sensors Journal, 17(7), pp.1981–1991. 1 Apr. 2017.
- [7]. S. K. Alshattnawi, "Smart Water Distribution Management System Architecture Based on Internet of Things and Cloud Computing", IEEE International conference on new trends in computing sciences, pp. 289- 294, 11 Jan. 2018.
- [8]. B. Zhou, C. Bian, J. Tong, S. Xia, "Fabrication of a miniature multiparameter sensor chip for water quality assessment", Journal of Sensors, vol. 17(1), 14 Jan. 2017. D. Nguyen, & P. H. Phung, "A Reliable and Efficient Wireless Sensor Network System for Water Quality Monitoring". In IEEE 2017 International Conference on Intelligent Environments (IE), pp. 84–91.
- [9]. S. Vaishali, S. Suraj, G. Vignesh, S. Dhivya, S. Udhayakumar, "Mobile integrated smart irrigation management and monitoring system using IOT", Proc. of IEEE International conference on Communication and Signal Processing, India, 08 Feb. 2018.