



## AN OVERVIEW: VISIBLE LIGHT COMMUNICATION

<sup>1</sup>Prof. Sarita Patil,<sup>2</sup>Prof. Sujata Albhar,<sup>3</sup>Prof. Nitin Shirirao

<sup>1</sup>Assistant Professor,<sup>2</sup>Assistant Professor,<sup>3</sup>Assistant Professor

<sup>1</sup>MCA Department,

<sup>1</sup>Siddhant Institute of Computer Application, Pune, India

**Abstract:** The term “Visible Light Communication” (VLC) refers to the communication technology that utilizes the visible light source as a signal transmitter, the air as a transmission medium, and the appropriate photodiode as a signal receiving component. Visible light is thus, by definition, comprised of usually-perceivable electromagnetic waves. The visible spectrum covers wavelengths from 380nm to 750 nm. In this paper, we have studied the main concepts of and challenges to VLC. In this paper, we have also studied the overview of VLC technology, from its physical aspects and communication architecture to its main applications and research challenges.

**Index Terms -** Visible light communication (VLC), optical Communication, Light emitting diode (LED), data transfer.

### I. INTRODUCTION

#### What is VLC TECHNOLOGY?

In telecommunication is used as “Visible light communication”. Visible light communication is the use of visible light as a communication medium. Visible light Communication is a subdivision of Optical Wireless Communication technology. In this technology it is used as fluorescent lamps to transmit signal at 10kbit/s and LED is used to transmit 500Mbit/s over a small distance. VLC can be used as transmission medium for all over the place computing, because light producing devices (such as indoor/outdoor lamps, TVs, traffic signs, commercial displays and car headlights) are used everywhere. The block diagram of visible light communication is as below.

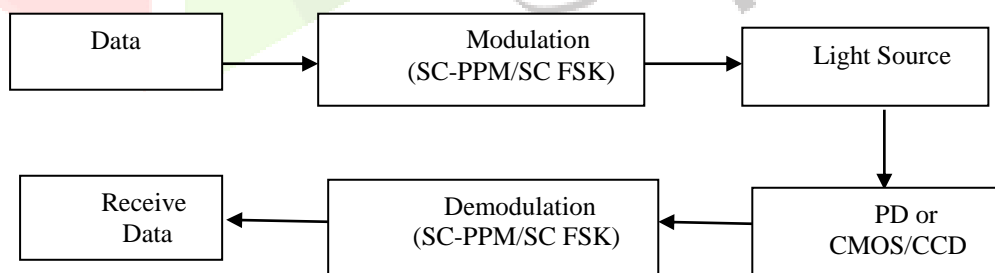

Fig. 1 Block Diagram of VLC

In sender side first data is appended from the user and then send to the Modulation Model. The modulation model is converting the data to the binary format it can be represented as a digital signal. Before converting the data is send to the light source module which generates the on/ off patterns of the LED's.

In receiver side, the receiver data module has a photodiode to detect On and Off states of the transmitting LED's. The photodiode module captures these sequences and generates the binary sequence of the received signal. The binary sequence is send to the demodulation module which converts the data into original format. It sends the data to the receiver data module which display the final result.

### Architecture of VLC

There are two parts of the VLC system first is the transmitter and second is the receiver. The transmitter and receiver are mainly three common layers. First is Physical Layer, Second is MAC Layer and final is Application Layer.

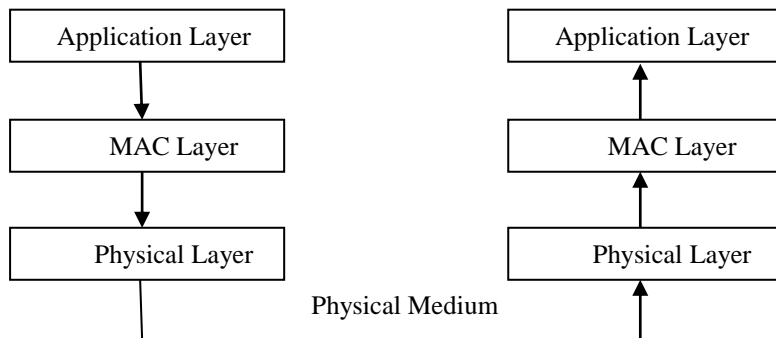

Fig.2 Architecture of VLC

### II. Optical Wireless Communication

Optical Wireless Communication (OWC) refers to broadcasting data using a random communication medium, such as visible light, infrared, or ultraviolet. In the 1960s, Bell Labs first transmitted data via laser beam, resulting in the growth of the field of OWC. On top of the decagon, research and application of OWS have concentrated on military and deep space communication, which has restricted chances for civilian use. The beginning of distributed infrared communication on the condition that it is a promising solution for short-range communication. Since VLC can be used for indoor and outdoor communications, VLC can be used to create smart lighting systems, vehicle-to-vehicle networks, and provide location-based services.

#### Architecture of OWC

Optical Wireless Communication there is three major subsystems. First is Transmitter, second is channel and third is receiver.

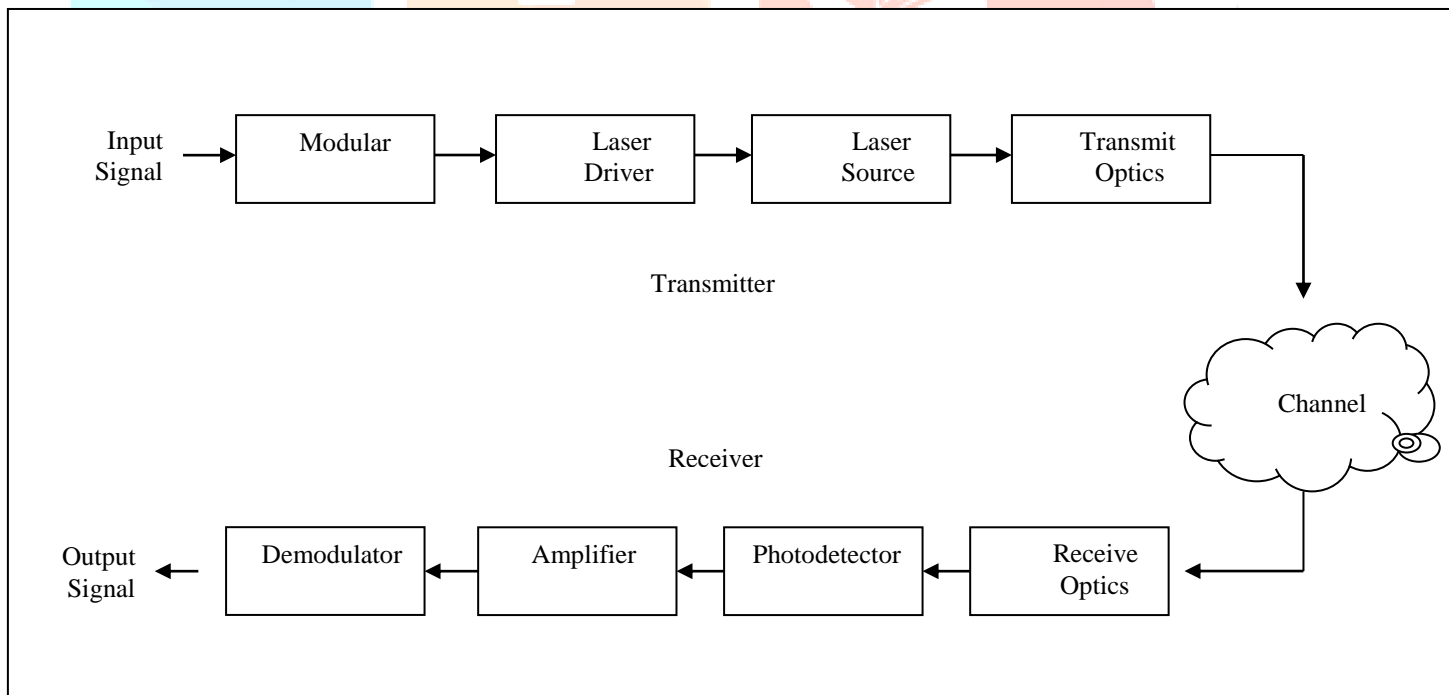

Fig. 3 Architecture of OWC

#### Transmitter

The goal of the transmitter is to transfer the information into a signal for a modular module. In this modulator, modulate the signal and send it to the laser driver. A laser diode acts as an optical source. The optical source converts information from the electric domain to an optical signal. The transmitting optics collects the signal and sends it to the receiver mode.

Channel

For the OWC, the channel it is a vacuum, atmosphere, or water. In case of the atmosphere channel faces very attenuation problem like fog, haze, cloud, and rain. Atmospheric turbulence is caused by random fluctuations of the refractive index of the medium due to random temperature fluctuations. Atmospheric turbulence is the main limiting factor for the performance of an FSO communication link.

Receiver

In the receiver, the optical signal is send to the receive optic and this signal is focus on photo detector. Photodetector module is convert optical signal into electrical forms. Then amplifier amplifies the signal and also increases the signal to noise ration. Then finally demodulator module gives the final output signal.

III. APPLICATIONS OF VLC

The application is used low energy cost and high transport cost and no impact on health and environment. These are following application of Visible Light Communication.

1) Li-Fi

Li-Fi is a wireless communication technology. Li-Fi uses light to transmit data and position between devices. Li-Fi is used in 802.11 protocols. It is transmitting data over the visible and infrared spectrums. A current example is LED lamps, which are used for the transmission of data in visible light. Li-Fi technology has a high-speed data transmission rate and a high-frequency rate of more than ten thousand times. Li-Fi technology consists of real-world applications of the Internet of Things, cell phones, and goods for sale. The mobile device's light display communicates with the color sensor on the product, which converts the light into digital information. Light-emitting diodes communicate synchronously from consumer products to cell phones.

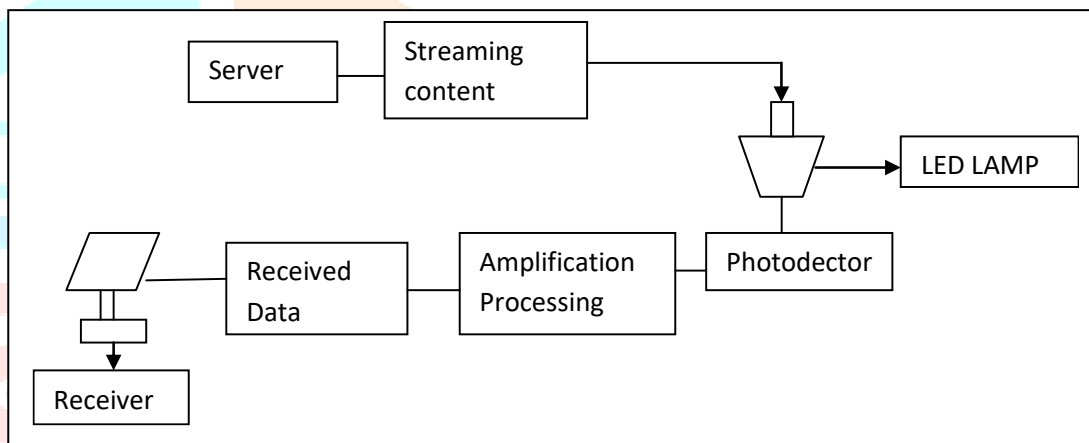

Fig. 4 Li-Fi System

2) Vehicle to vehicle Communication

The VLC technique is discovered. Vehicle-to-vehicle light communication VLC can be used for vehicle communication due to the existing vehicle lighting and traffic light infrastructure. LED is based on traffic lights, street lights, and car lights. Vehicles not only can communicate with each other but also can communicate with traffic lights using Li-Fi technology. The vehicle safety communication application project includes emergency electronic brake lights, pre-crash sensing, lane change warning, left turn assistant, traffic signal violation, and stop sign movement assistant. All of this high-priority application requires dependable reachability with low latency.

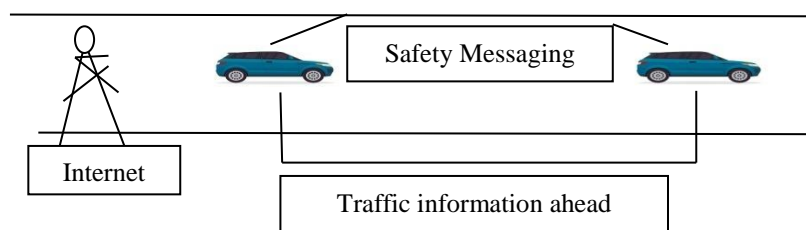

Fig. 5 Vehicle to Vehicle Communication

### 3) Underwater communication

Radio frequency waves do not travel well in sea water because of its good conductivity. Therefore, VLC communication should be used in underwater communication networks; it stands for UVLC. The VLC is an untethered, remotely operated vehicle. UTROV performed different work, like observatory maintenance of the oceans and deployment opportunities from the ships. Underwater communications are used for data collection and analysis, underwater environment monitoring, water pollution, early warning of floods or tsunamis, and global warming caused by rising ocean levels.

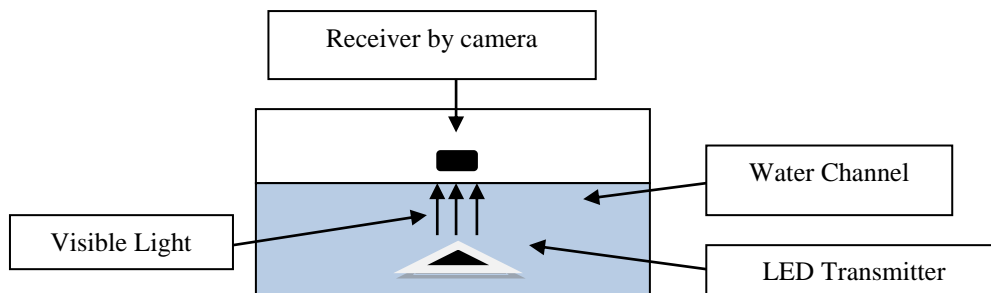

Fig.6 Underwater Communication System

### IV. Conclusion

In this paper, we have studied concepts and application of Visible Light Communication. Visible Light Communication is providing wireless communication. We observe in current market it is high demand of wireless resources and it is populated by the mobile devices. This high demand of wireless resources and communication raises a series of issues related to the current infrastructure of wireless networks. In this paper, we can identify the upcoming Wi-Fi spectrum, where the demand for resources becomes greater than the capacity offered by the network.

### References

- [1] J Pierre De Vries, Ljiljana Simic, Andreas Achtzehn, Marina Petrova, and Petri Mähönen. The wi-fi “congestion crisis”: Regulatory criteria for assessing spectrum congestion claims. *Telecommunications Policy*, 38(8):838–850, 2014.
- [2] Stefan Schmid, Giorgio Corbellini, Stefan Mangold, and Thomas R Gross. Led-to-led visiblelight communication networks. In *Proceedings of the fourteenth ACM international symposium on Mobile ad hoc networking and computing*, pages 1–10. ACM, 2013.
- [3] Shlomi Arnon. *Visible light communication*. Cambridge University Press, 2015.
- [4] Weiping Sun, Okhwan Lee, Yeonchul Shin, Seongwon Kim, Changmok Yang, Hyoil Kim, and Sunghyun Choi. Wi-fi could be much more. *IEEE Communications Magazine*, 52(11):22–29, 2014.
- [5] Aleksandar Jovicic, Junyi Li, and Tom Richardson. Visible light communication: opportunities, challenges and the path to market. *IEEE Communications Magazine*, 51(12):26–32, 2013.
- [6] Xiaoming Zhu and Joseph M Kahn. Free-space optical communication through atmospheric turbulence channels. *IEEE Transactions on communications*, 50(8):1293–1300, 2002.
- [7] Rui Hou, Yawen Chen, Jigang Wu, and Haibo Zhang. A brief survey of optical wireless communication. In *Proc. Australas. Symp. Parallel Distrib. Comput.(AusPDC 15)*, volume 163, pages 41–50, 2015.
- [8] Stefan Schmid, Theodoros Bourchas, Stefan Mangold, and Thomas R Gross. Linux light bulbs: Enabling internet protocol connectivity for light bulb networks. In *Proceedings of the 2nd International Workshop on Visible Light Communications Systems*, pages 3–8. ACM, 2015.
- [9] Stefan Schmid, Thomas Richner, Stefan Mangold, and Thomas R Gross. Enlighting: An indoor visible light communication system based on networked light bulbs. In *Sensing, Communication, and Networking (SECON)*, 2016 13th Annual IEEE International Conference on, pages 1–9. IEEE, 2016.
- [10] Kaiyun Cui, Gang Chen, Zhengyuan Xu, and Richard D Roberts. Traffic light to vehicle visible light communication channel characterization. *Applied optics*, 51(27), 2012.