



Exploring The Effect Of Material Variation, Tooth Count, On Spur Gears Strength And Weight

¹Nirav Meghpara, ²Jasmin Bhimani, ³Pooja Ghodasara

^{1,2,3}Assistant Professor, Mechanical Engineering Department, VVP Engineering College, Rajkot, India

Abstract: This research paper explores the use of five different materials, including Gray Cast Iron (FG 350), Malleable Cast Iron (Whiteheart), Bronze (Sand Cast), Steel (30C8), and Cast Steel (Grade-1) Hardened & Tempered, for designing spur gears based on strength and wear criteria. The study varied the number of teeth from 17 to 25 and drew graphs for beam strength, wear strength, and total weight of the pair with the material as the legend. The results show that increasing the number of teeth improves strength irrespective of the material. Steel exhibits the highest beam strength, while Malleable Cast Iron (Whiteheart) has the lowest. Gray Cast Iron provides the maximum wear strength, while Bronze has the least wear strength. Furthermore, the overall weight of the pair is highest for Bronze and lowest for Gray Cast Iron. These findings can assist engineers in selecting appropriate materials for spur gear design, optimizing their performance and weight characteristics..

Index Terms - Spur gear, beam strength, wear strength, total weight.

I. NOMENCLATURE

| | |
|------------|---|
| m | Module (in mm) |
| z | Number of teeth |
| b | Face width (in mm) |
| σ_b | Permissible bending strength (in MPa) |
| S_{ut} | Ultimate tensile strength (in MPa) |
| Y | Lewis form factor |
| S_b | Bending strength (in N) |
| S_w | Wear strength (in N) |
| Q | Ratio factor |
| K | Load-stress factor |
| σ_c | Surface endurance strength of the material (in MPa) |
| d | Pitch diameter (in mm) |
| E | Modulus of elasticity (in MPa) |
| kW | Power (in kW) |
| BHN | Brinell hardness number |
| M_t | Torque (in N-mm) |
| P_t | Tangential force (in mm) |
| P_{eff} | Effective tangential force (in N) |
| C_s | Service factor |
| C_v | Velocity factor |
| α | Pressure angle (in degree) |

II. ABBREVIATION

| | |
|-------|---------|
| p | Pinion |
| g | Gear |
| min | Minimum |

III. INTRODUCTION

A spur gear is a type of cylindrical gear in which the teeth are parallel to the axis of rotation. It is commonly used to transmit power and motion between parallel shafts in a wide range of industrial applications, including machinery, automobiles, and appliances. Spur gears have many advantages, including their ability to provide a high level of accuracy and efficiency, as well as being easy to manufacture and maintain. They can be designed to handle high loads and can operate at high speeds without significant wear and tear.

Madhusudan. G [1] described the approach to spur design in educational aspect and yield systematic detailed design of spur gear based on different load conditions whether its static ,dynamic or wear load. Simplified design method for spur gear was presented by Edward E. Osakue [2] which appeared as an acceptable approach in the primary design level of spur gear. This has been reformulated from Hertz contact stress and Lewis root bending stress. Divyesh B. Asodariya [3] adopted meta heuristic optimization technique to design a spur gear under different optimal parameters. In this research, the parameters were analyzed by both method ie analytical and using genetic algorithm, the result obtained by both were compared and found in good agreement to each other.

The current research article used the mechanical properties of Gray Cast Iron (FG 350), Malleable Cast Iron (Whiteheart), Bronze (Sand Cast), Steel (30C8), and Cast Steel (Grade-1) for computing beam strength wear strength and total weight of the pair.

IV. TYPE STYLE AND FONTS

In the design of gear, it is required to decide the number of teeth on the pinion and gear. There is a limiting value of minimum number of teeth on pinion. The minimum number of teeth to avoid interference is given by,

$$z_{min} = \frac{2}{\sin^2 \alpha}$$

In the design of gear, it is required to express the face width in terms of module. The optimum range of the face width is,

$$8m < b < 12m$$

In the preliminary stages of gear design, the face width is assumed as $b=10m$.

Beam strength is the maximum value of the tangential force that the tooth can transmit without bending failure.

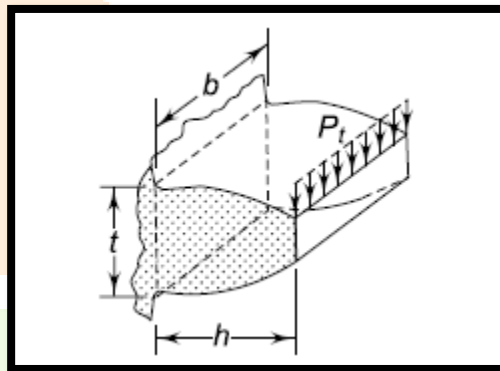

Figure 1 Gear tooth as cantilever

The equation of beam strength is,

$$S_b = m b \sigma_b Y$$

Where,

$$\sigma_b = \left(\frac{1}{3}\right) S_{ut}$$

Wear strength is the maximum value of the tangential force that the tooth can transmit without pitting failure.

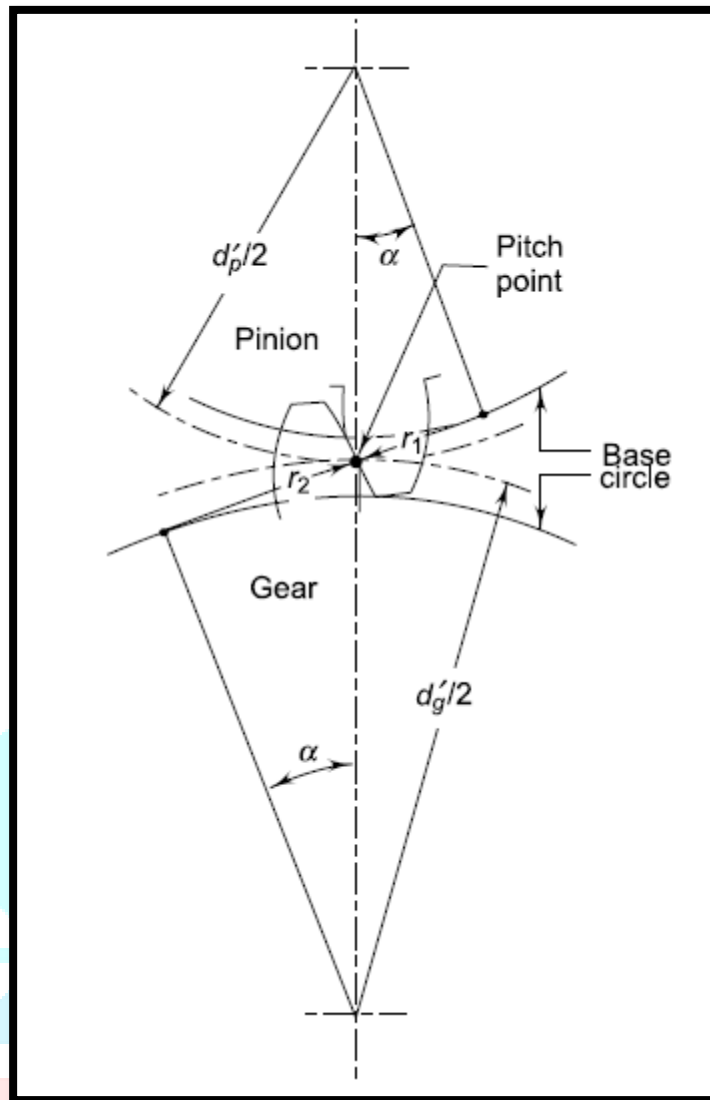

Figure 1 Contact between two meshing teeth at the pitch point

The equation of wear strength is,

$$S_w = b Q d_p K$$

Where,

$$\text{For internal gears, } Q = \frac{2 z_g}{z_p + z_g}$$

$$K = \frac{\sigma_c^2 \sin \alpha \cos \alpha \left(\frac{1}{E_p} + \frac{1}{E_g} \right)}{2}$$

$$\sigma_c = 0.27 \times 9.81 \times BHN$$

To determine the tangential component of the resultant force between two meshing teeth following equation are used.

$$M_t = \frac{60 \times 10^6 (kW)}{2\pi n}$$

$$P_t = \frac{2M_t}{d}$$

The effective load between two meshing teeth is given by,

$$P_{eff} = \frac{C_s P_t}{C_v}$$

V. RESULTS AND DISCUSSION

Spur gear is designed under given condition,

Input power = 7.5 kW

Input shaft speed = 1000 RPM

Output shaft speed = 250 RPM

Pressure angle = 20 degree

Results are computed by varying number of teeth from 17 to 25. Based on the obtain results, variation of beam strength, wear strength and total weight of the pair are plotted by varying number of teeth.

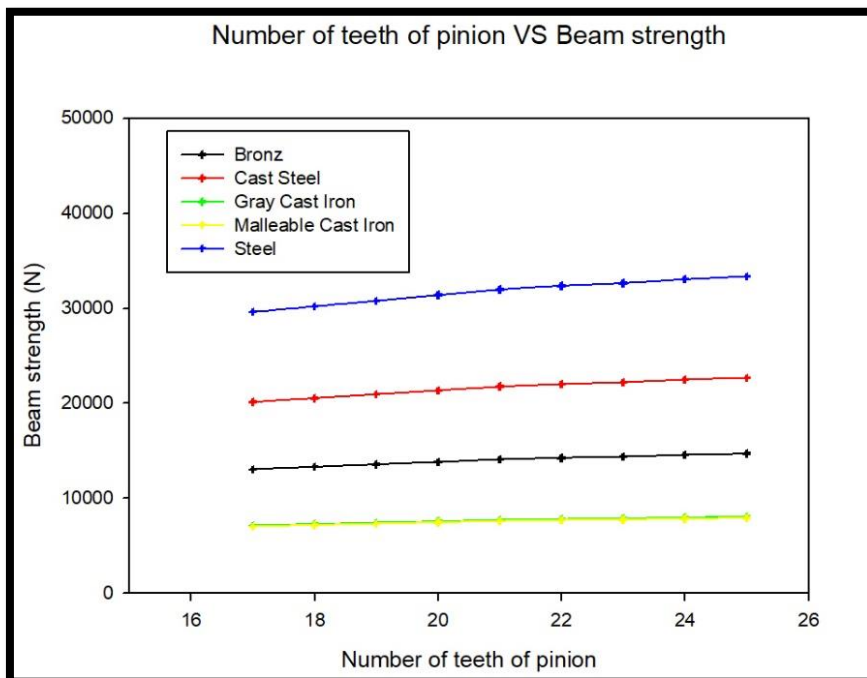

Figure 2 Number of teeth vs Beam strength

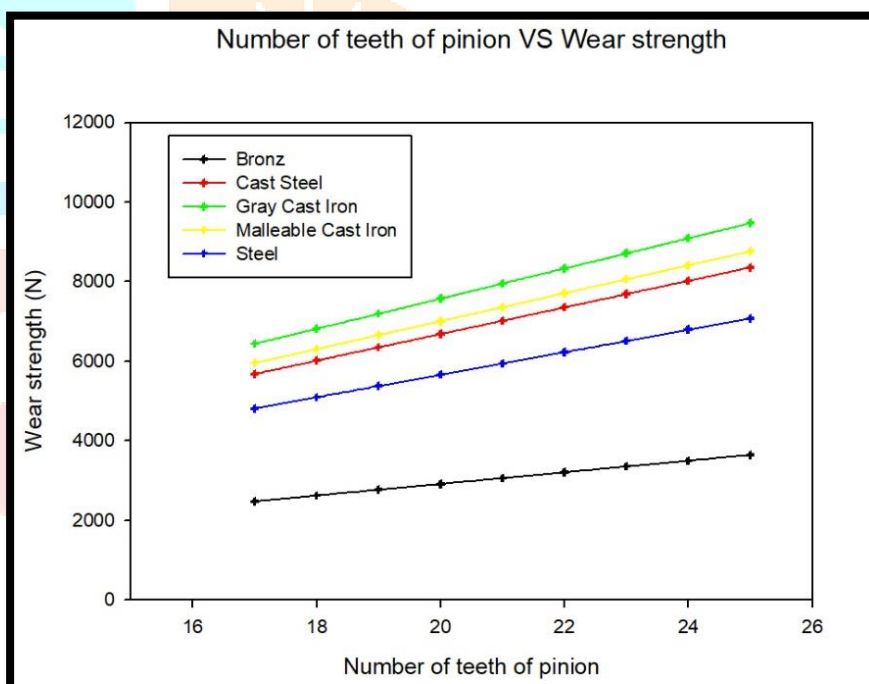

Figure 3 Number of teeth vs wear strength

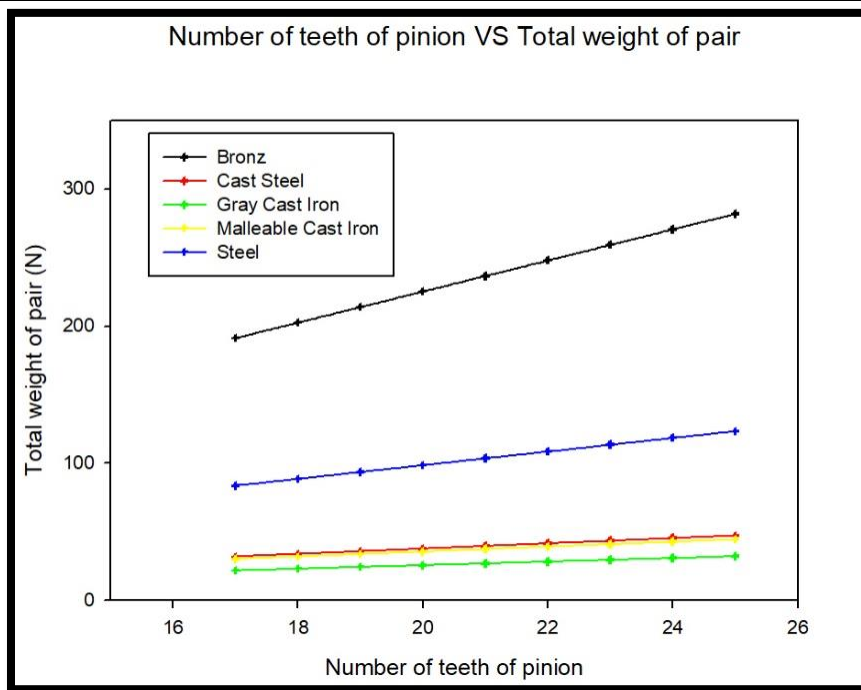

Figure 4 Number of teeth vs Total weight of pair

VI. CONCLUSION

After computing the results, we can conclude the following things,

1. If the selection of gear pair is based on weight criteria, we should select gear material as Gray Cast Iron. Because it has the least weight among all other material that we have considered for the study.
2. We are getting maximum beam strength in Steel material and maximum wear strength in Gray Cast Iron material.

REFERENCES

- [1] Madhusudan, G., and C. R. Vijayasimha. "Approach to spur gear design." *Computer-Aided Design* 19.10 (1987): 555-559.
- [2] Osakue, Edward E. "Simplified Spur Gear Design." *ASME International Mechanical Engineering Congress and Exposition*. Vol. 50657. American Society of Mechanical Engineers, 2016.
- [3] Asodariya, Divyesh B. "A Comparative Study of Multi Objective Decision-Making Methods to Design a Spur Gear under Optimum Parameters." (2022).
- [4] Bhandari, V. B. "Design Data Book."