



DEEP LEARNING TECHNIQUES USED FOR FAKENEWS DETECTION: A REVIEW AND ANALYSIS

Sumaira Farooq , Saqib Gulzar Bhat

1. ABSTRACT

Smart People can quickly obtain and publish the news through many platforms i.e., social media, blogs, and websites, among others. Everything that is available on these plat-forms in not credible and it became imperative to check the credibility of articles be-fore it provesto be detrimental for the society. Multiple initiatives have been taken up by platforms like twitter and Facebook to check the spread of fake news omits platforms. Several researches have been undertaken utilizing machine learning (ML) and deep learning (DL) methodologies to address the problem of determining the re-liability of news. Traditional media solely employed textual content to spread in-formation. However, with the introduction of Web 2.0, fake images have become more readily circulated. The news piece, along with the graphic statistics, lends credibility to the material. The picture data is occasionally supplemented with the news pieces. For this research the prime focus is DL based solutions for text-based fake news detection. This research discusses about various techniques to automated detection of fake news. The paper gives a comparative analysis of various techniques that have been successful in this domain. Various datasets that have been used frequently are also highlighted. Despite various researches have been conduct-ed for tackling fake news, these approaches still lack is some areas like multilingual fake news,early detection and so on.

Keywords–Fake news detection; social nets; deep learning; Long-Short Term Memory (LSTM); text classification; words embedding technique

2. INTRODUCTION

The People obtain and share information through social media, which has become an essential information platform. Its growing popularity has also allowed for the wide-spread distribution of false information, which has enormous detrimental consequences for society. As a result, it is vital to identify and control

fake news on these platforms in order to ensure that customers obtain correct information and social harmony is maintained. The traditional media used only the textual content to spread the data. But with the advent of Web 2.0, the fake images are also widely circulated. The news article along with the visual data makes the content appear credible. The news articles are sometimes complemented with the image data as well. So, the fake content that is spread online can be detected using Visual-based approaches [1], Linguistic-based approaches [2],[3],[1],[4],[5], multimodal -based approaches [6],[7][5]. The majority of social media users are naive, and they are influenced by misleading information spread on these sites. They may unwittingly disseminate the misleading content and encourage others to do so by commenting on it. Some political analysts feel that misinformation and rumors had a role in Donald Trump's win in the 2016 US presidential election [2],[3].

The earlier approaches used various ML methods for fake news detection. But, with the extreme use of online platforms the content that is present online is increasing exponentially. The ML techniques are not much efficient to handle this amount of data. DL techniques on the other hand does automatic feature selection are therefore have proved effective for FND problem.

The contribution of the paper is three-folds. The paper discusses about various types of fake news items that are shared on online platforms, and provides taxonomy of recognition techniques. The main focus of this paper exists the DL approaches for text-based detection of fake news. A complete review of literature is provided apart from a comparative analysis of various datasets. The paper provides an outline of a general framework of a detection of fake news model. The paper also identifies and addresses various gaps or issues that still exist in fake news detection.

2.1. DEEP LEARNING MODELS FOR DETECTION OF FAKE NEWS:

- Due to the over growing use of social broadcasting over the past decades, and the efficiency of creation of the tempered content, it becomes very difficult to detect the fake content.
- The existing approaches [8][9][10] used machine learning techniques. But with the amount of data available the trend has shifted to deep learning-based detection approaches [11][12][4] as these are very efficient in extracting the features from huge data.
- The Convolutional Neural Network (CNN) networks particularly are used significantly in computer vision task. Text-CNN, a variant of CNN also performs very well of Natural Language Processing tasks as well [10].
- The Recurrent Neural Network (RNN) based models are very efficient in memorizing the long-term dependencies in the text. Variants of RNN i.e., LSTM, gated recurrent unit (GRU) and other gated networks are also widely used. The following sections discuss about various deep learning algorithms that are widely used for Detection of Fake News.

A. **Convolutional Neural Networks (CNN):** CNNs are capable of detecting patterns and have been effectively used to extract features from both pictures and text. The convolutional layer and the pooling layer are the two primary components of CNN. The convolutional layer is made up of a collection of learnable filters that slide over the matrix's rows [13]. In existing papers [9][14][15], the authors suggest a Text-Image CNN (TI-CNN) model for detecting false news that takes into account both text and visual information. Beyond the explicit features retrieved from the data, convolutional neural networks are used to study the latent properties that are not captured by the explicit features, as part of the development of representational learning.

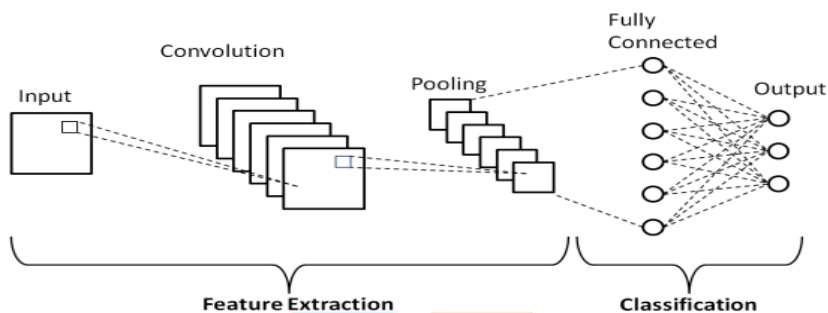

Figure 1: Convolutional Neural Network [16]

B. **Recurrent Neural Network (RNN):** RNNs are artificial neural networks that create a directed or undirected graph of nodes over time. This enables it to behave in a temporally dynamic manner. RNNs, which are descended from feed forward neural networks, can manage variable length input sequences by utilizing their internal state (memory) [15],[13],[17]. Recurrent neural networks can run any pro-gramme to handle any sequence of inputs, [8],[11]. Bahad et al. [9] presented at RNN, which merges multimodal characteristics such as textual and visual data, as well as user profile features, and leverages the attention mechanism to align features.

C. **Long Short-term memory (LSTM):** The LSTM is a kind of recurrent neural network. The preceding step's output is utilized as an input in the current RNN stage. It addressed the issue of RNN long-term dependence, which happens when an RNN is unable to predict words stored in long-term memory but is able to provide more accurate predictions based on current data [18]. LSTMs were developed to address the issue of vanishing gradients that may arise when using normal RNNs for training. The Internal Cell State is not tracked by the LSTM because it only has three gates. The information preserved in the Internal Cell State of an LSTM recurrent unit is incorporated in the Gated Recurrent Unit's hidden state. This data is gathered and sent to the next Gated Recurrent Unit.

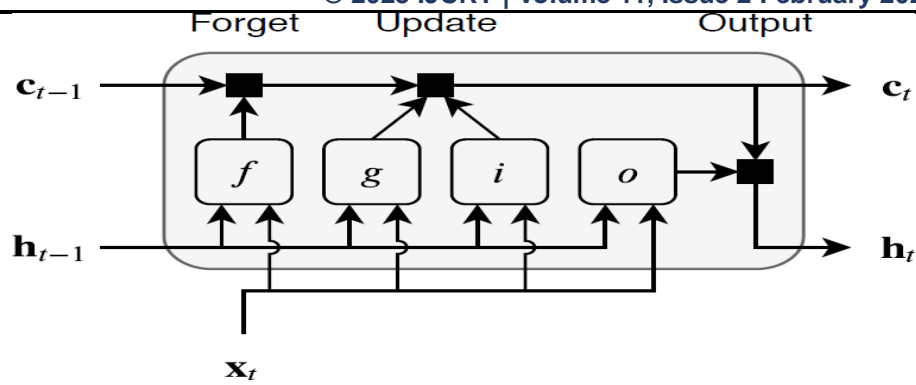

Figure 2: Architecture of LSTM [19]

D. **Bidirectional LSTM/RNN:** BiLSTM (Bidirectional LSTM) is a kind of LSTM that increases model presentation on sequence classification problems [16]. It's a two- LSTM sequence processing paradigm with one for forward processing and the other for backward processing. For natural language processing tasks, bidirectional LSTM is a common solution.

E. **Gated recurrent units (GRUs):** Cho et al. [16] introduced the Gated Recurrent Unit (GRU), a well-known recurrent network variant that uses gating algorithms to govern and manage info flow between neural network cells. As seen in Fig. 3, the GRU is comparable to an LSTM but has fewer parameters since it includes a re-set gate, an update gate, but no output gate. The primary difference between a GRU and an LSTM is that the GRU has two gates (reset and update gates), whereas the LSTM has three gates (namely input, output and forget gates)

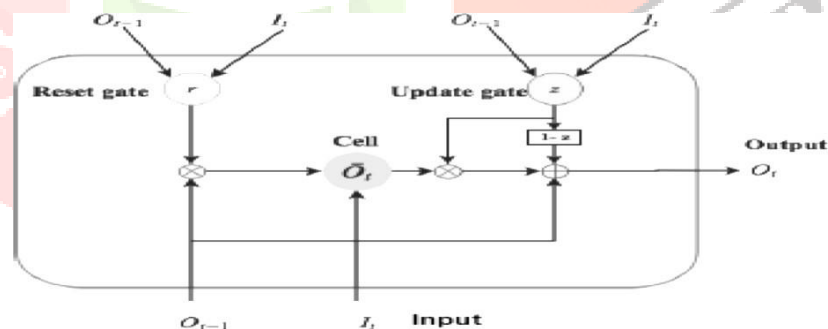

Figure 3: A gated recurrent unit (GRU) cell's basic structure consists of reset and up-dated gates [16].

2.2 FAKE NEWS DETECTION TAXONOMY:

For the aim of algorithm-based detection of fake news, we establish a taxonomy that classifies the detection methods as: feature-based, ML-based, platform-based, languages-based, and detection level-based.

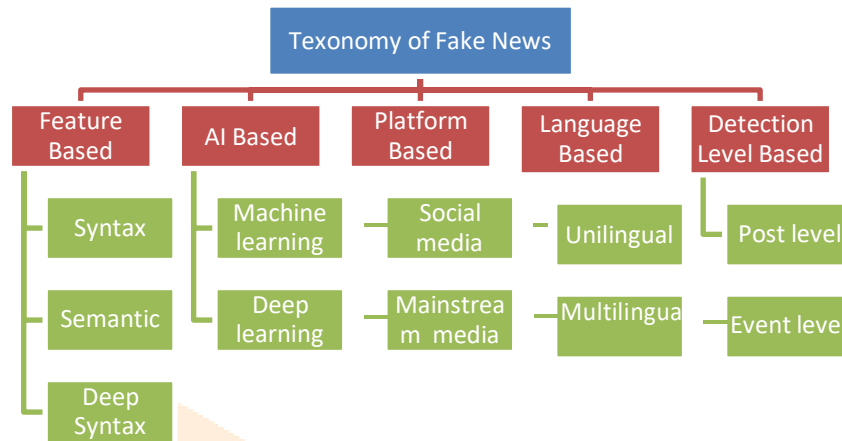

Figure 4: Taxonomy of paradigms for fake news detection.

A. **Feature based:** This method relies on a person or software algorithm using linguistics to detect fake news [3]. The study in [4] presents a unique text analysis-based computational technique for detecting fake news automatically. The linguistic based methods can be further classified on the basis of:

i. **Semantics:** Semantic features are those that produce a collection of shallow meaning representations, such as sentiment, named entities, or relations researchers [22] describe a novel semantic false news detection system based on relational properties retrieved directly from text, such as sentiment, entities, and facts.

ii. **Syntax:** The word analysis is insufficient for predicting false news, other linguistic methodologies, such as syntax and grammar analysis, must be used taken into account. Researchers have transformed texts into parse trees that characterize sentence structure using Probability Context-Free Grammars (PCFG) [23][24].

iii. **Deep syntax:** Probability Context Grammars [2] are used to implement the deep syntax technique. Probability Context Free Grammars, which perform deep syntactic tasks via parse trees, enable Context Free Grammar analysis. Context Free Grammars [4] has been extended to include Probabilistic Context Free Grammar. Sentences are broken down into a collection of rewrite rules, which are then used to analyse different syntax patterns. The syntax can be compared to recognized structures or patterns of lying to help determine if something is real or not [24].

B. **Artificial Intelligence (AI) Based:** various approaches for FND have been studied in the literature.

ML and DL methods are two widely used techniques for FND.

i. **Machine learning:** Machine learning is a type of artificial intelligence that allows computers to learn from prior data and complete tasks on their own. The study [18] proposes an SVM-based technique for recognizing satirical news based on factors including absurdity, humor, syntax, and punctuation. The models had an accuracy rate of 90% and a recall rate of 84%. The purpose is to decrease the negative impact of spoof news on the general audience.

ii. **Deep learning:** Deep learning is a highly specialized subset of machine learning. Deep learning is based on a layered structure of algorithms known as an artificial neural network. In this study, researchers learn the problem of fake news discovery. They concentrate on fake news finding styles grounded on text-features [25].

C. **Platform Based:** This is about the digital environment in which the dataset's news is shared and distributed to the public. To detect fakes news, the researchers used two distinct sorts of media sites.

i. **Social Media:** It's a double-edged sword to use social media for news update. Researchers conduct a detailed comparative evaluation of several techniques using datasets provided by the Verifying Multimedia Use (VMU) task developed in the scope of the 2015 and 2016 mediaeval benchmarks [26].

ii. **Mainstream Media:** Mainstream Media (MSM) is a media of communication may be defined as those that deliver consistent messages in a one-way process to a big, homogeneous audience with similar features and interests. It is concerned with various news websites for collection and analysis of fake data like Washington post, CNN, PolitiFact etc. Many fake sites are also used to circulate misleading data. Fake-Newsnet [27] is a multimodal fake news repository that has its data collected from two websites namely PolitiFact and gossip cop.

D. **Language Based:** On the basis of the number of languages considered by the models, the FND model is usually bifurcated as Unilingual and multilingual;

i. **Unilingual:** Many existing models have used only a single language for text-based FND. To recognize fake news in Persian texts and tweets, researchers created an LSTM hybrid model using a 14-layer bidirectional long short-term memory (BLSTM) neural network [28]. Based on the findings, the suggested model has a 91.08 percent accuracy rate in fake news detection and rumors.

ii. **Multilingual:** The propagation of fake news is a global issue, in [19] research assesses textual qualities that are not bound to a single language when defining textual data for news detection. Complexity, stylometric, and psychological text aspects were investigated using corpora of news articles in American English, Brazilian Portuguese, and Spanish. Researches in [19],[22],[23] have retrieved traits to distinguish between fraudulent, authentic, and satirical news in multilingual environment.

E. **Detection Level Based:** On the basis of the type of detection level, a FND model can be either a Post level detection model or event-level detection model.

- i. **Post level:** It only includes the tweet or post at hand, other auxiliary information is not considered.
- ii. **Event Level:** Apart from the tweet or post, it also considers other auxiliary information like other post that is relevant to the post that is being considered. Existing deep learning models have made significant progress in tackling the challenge of detecting false news [31][32].

3. LITERATURE REVIEW:

The review of literature highlights previous research and experiments on fake news detection using machine learning and deep learning. Researchers present in paper [15] about LSTM RNN infrastructures for large scale aural modeling in speech recognition. They use a mongrel approach for aural modeling with LSTM RNN where Hid-den Markov model (HMM) state posteriors are estimated using neural networks. Researchers in [13], present an analysis of n- gram and machine learning-based fake news detection method. They investigate and compare two distinct ways of giving birth and six various ways of using machine brackets. Using a point birth method of Term Frequency-Reversed Document Frequency (TF-IDF) and a classifier of Linear Support Vector Machine (LSVM), experimental appraisal provides the stylish donation with a delicacy of 92. On behalf of fake news, they united to construct a fake news dataset on kaggle.com.

Various articles have discussed a detection of fake news model based on Bidirectional LSTM-intermittent neural network. The result network in [13], two intimately available unshaped newspapers datasets are used to estimate the presentation of the model.

Fake news detection using unidirectional LSTM, in terms of accuracy, the LSTM-RNN model surpasses the original CNN model [14]. In this learning, a model LSTM and 14- subcaste are utilized to detect fake news in Persian texts and tweets [17], researchers used a BiLSTM neural network. Based on the obtained findings, the suggested model has 91.08 accuracy in detecting fake news and rumors. According to the confusion matrix, the researcher's models' performance capability is 92.04, their recall is 91.09, and their f1 criteria are 91.57. They also compare the results, to Bayesian, k-NN, arbitrary wood, direct Retrogression, Perceptron neural network, SVM, decision tree, Probabilistic grade, Ada boost, grade boost, and redundancy tree methods.

Accordingly, the current exploration [28] strives to illuminate on false update problem and the procedure of relating false news using deep literacy approaches. According to the Fake News Challenge (FNC-1) dataset, we've developed different models to descry fake news. Bidirectional LSTM [15] are all used in our models (Bi-LSTM) In the negative of other studies on the same dataset where they reported delicacy for a test data deduced from thesame training dataset, the trials achieved71.2 delicacy for the sanctioned testing dataset.

In paper [18], the TI-CNN (Text and Image Information Grounded Convolutional Neural Network) model is explored. TI-CNN is simultaneously trained using text and image information by projecting the unambiguous and idle characteristics into a single point space. The usefulness of TI-CNN in solving the fake news detecting challenge has been proved by extensive examination of real-world fake news datasets. The dataset in these paper sweats on the news about [17] American presidential election. They'll edge further data about the France public choices to further probe the differences among true and false news in other languages.

In this study [25], researchers learn the problem of fake news discovery. They concentrate on fake news finding styles grounded on text-features. Experimenters recommend a mongrel CNN-LSTM model as a combination of a convolution layer, used to extract unlabeled features [19] and the LSTM layer was utilized to capture long-term sequence dependencies in order to learn a regulatory grammar and increase prediction accuracy. Trials on two real-world datasets show the CNN-LSTM model's exceptional delicacy in recognizing fake news. Researchers [34] discussed about an ensemble bracket model for detecting bogus news in this composition that beat the state-of-the-art Decision Tree, Random Forest, and Extra Tree Classifier. On the ISOT dataset, experimenters obtained training and testing accuracy of 99.7 and 44.14, respectively. For the Fabricator dataset, they obtained 99 percent training and testing accuracy.

4. DATASETS FOR DETECTING FAKE NEWS

This section gives an overview of the various datasets available for FND. Table 1 provides a comparative analysis of various frequently used datasets. These datasets are collected from various online platforms and main-stream media websites.

Table 1. Comparison of various available datasets

Dataset	Year of release	Platform	Content type	Data category	Total No of claims	Label	No. of items
CREDBANK	2015	Twitter	News items posted on twitter	Variety	60,000,000	5-point credibility scale	1049
Buzz Face	2016	Facebook	News items posted to the Facebook by nine new outlets.	Political	2263	Mostly true, mostly false, mixture of	1656, 104, 244,

						true and	259
						false, no	
						factual	
						content	
PHEME	2016	Twitter	Nine different	Variety	330	False,	250,
			newsworthy			True	4812
			events				
LIAR	2017	PolitiFact	Political	Political	12836	Pants-on-	1050
		t	statements			fire, false,	
						slightly	Others
						true, half	2063-2638
						true,	
						largely	
						true, and	
						true	
Fake Newsnet	2020	Twitter	US Politics,	Political/	602,659	Fake and	420
			Entertainment	celebrity		true	,528
							(PolitiFact)
							,4947
							,16694(Gos
							sip Cop)

- A few patterns emerge when comparing fake news databases. The majority of the datasets are small, which can make existing deep learning models that need huge quantities of training data inefficient.
- Only few datasets have more than half a million samples, the largest of which being CREDBANK and FakeNewsCorpus, which each have millions of samples. Furthermore, many databases' categories their data in a restricted number of ways, such as false vs. true.
- More fine-grained labeling may be found in datasets like, LIAR, and FakeNewsCorpus. While several datasets incorporate data from a number of groups, others focus on specialized topics like politics and Gossip Cop. Because of the small number of categories, these data samples may have restricted context and writing styles.
- Fake Newsnet [35], a multimodal dataset that includes text as well as images with it, is not available in their whole but can be retrieved as sample data. This is mostly due to the fact that the bulk of these datasets use Twitter data for social settings and hence is not publicly available per licensing

regulations.

- The LIAR dataset is generally well-balanced in terms of labels: with the exception of 1050 pants-fire incidents, the occurrences for all other labels vary from 2063 to 2638. The given datasets are outdated and out of date. Such datasets are un-suitable for addressing the issue of fake news data for recent news data since the techniques of fake news producers vary with time.

5. COMPARATIVE ANALYSIS AND DISCUSSION

A comparison of several fake news detecting techniques: Table 1 summarizes the findings of a study of several false news detection algorithms based on machine learning and deep learning offered by various researchers.

Table.2: Analysis of various fake news detection techniques

Ref	Year	Contributions	Technique used	Dataset	Result (Acc)	Challenges
[1]	2018	LSTM RNN Infrastructures for large scale aural modeling in speech recognition.	LSTM, RNN	LIAR	79%	Does not achieve higher accuracy
[2]	2018	The feature extraction approach is Long Short-Term Memory (LSTM)	LSTM	Kaggle	92%	Only text-based characteristics are used to identify fake news.
[3]	2018	New features for training classifiers have been added.	Transformer-Based Approach	There are 2482 news stories on the US election.	85%	Only a little dataset is available. Authors should be able to employ a large number of datasets in the future, as well as deep learning algorithms with superior fake news forecasting.

[4]	2019	By verifying tweets using specific taught characteristics,	BiLSTM-CNN	5400 twitter tweets	86.11%	Only text-based characteristics may be used to classify if something is fake or not.
[5]	2019	BiLSTM is a machine learning algorithm that detects bogus newsin Persian texts and tweets.	BI-LSTM	Liar dataset	91.07%	To classify whether something is false or real, they can only use text-based characteristics.
[6]	2019	CNN-LSTM is usedto identify fake news based on the relation between article headline and article body	CNN-LSTM	There are 3482 news stories on the US election.	71.2%	Does not achieve Higher accuracy.
[7]	2020	TI-CNN is trained with both text and visual data at the same time.	TI-CNN	The dataset efforts on the news about American presidenti al election	60% to 94%	Does not attain a greater level of accuracy, and is limited to a small data set.
[8]	2021	using an ensemble model that combines three widely used machine learning models, namely, Decision Tree, Random Forest and Extra Tree Classifier	Decision Tree, Random Forest and Extra Tree Classifier	ISOT and LIAR	99.8%-99.9% Liar	Only text-based characteristics may be used to classify if something is fake or not.

Random Forest and

Extra Tree

Classifier.

[9]	2021	Three sets of characteristics linked to linguistic, user-oriented, and temporal propagation were presented.	Bi-directional LSTM-Recurrent Neural Network	Twitter and Weibo	90%	The sample was limited to 1,111 Twitter posts and 818 Weibo posts.
[10]	2021	All semantic features, user-based features, structural features, sentiment-based features, and predicted features were projected into a classifier.	Deep Diffusive Neural Network	400K official media articles and 60K erroneous information in an Italian Facebook data collection	90%	Failed to identify the factor that has a detrimental influence on the information.

- Platform content available on social media is less as compare to the mainstream media, therefore the textual methods for FND performs better in such cases.
- When the text data on online platform is complemented with the propagation data, user information for detection, such methods perform better. When huge amount of data is used, DL methods perform better than the ML because feature engineering is done automatically.
- The comparison analysis on various basis above table shows that while performing FND for LIAR dataset using LSTM RNN approach has accuracy of 79% means it does not achieve higher accuracy, while researchers developed a hybrid model of long short-term memory (LSTM) and a 14-layer bidirectional long short-term memory (BiLSTM) neural network [28]. Based on the findings, the suggested model has a 91.08 percent accuracy rate in detecting fake news and rumors in deep learning.

- The study examines many DL approaches for FND, among which LSTM may learn long-term dependencies and hence accomplish multiple problems that prior learning algorithms for recurrent neural networks were unable to perform (RNNs). Furthermore, Bidirectional long-short term memory (Bidirectional LSTM) outperforms LSTM since input flows in both directions and data may be used from both sides. It may also be used to simulate the sequential interactions between words and sentences in both directions.

6. GENERAL FRAMEWORK

The next part gives a generic framework for FND (Figure 5) to define if a given news article is real or fake based on the text data. The process starts from selecting and preprocessing the dataset. The comparison of various datasets is available in above section 4 table 1.

- Apart from the datasets that are available various webs API's can also be used for collection of raw data. The data collecting technique for developing a fake news detection system is determined by the task specification.
- In earlier research, examples of fake news were gathered from a list of suspect websites. Fake detection, fact-checking, truthfulness categorization, and rumor detection are just some of the uses for datasets. The first is a forecast that a certain piece of information (news item, review, remark, etc.) will be purposely false.
- Fact-checking is the process of analyzing and confirming factual statements contained in a piece of information; unlike false detection, fact-checking functions at the statement or claim level. In that it attempts to anticipate whether or not a piece of information is true, veracity classification is comparable to fake detection. Finally, rumor detection seeks to differentiate between confirmed and un-verified information (rather than true or false), with unverified information having the potential to be true or false or to stay unresolved [36].

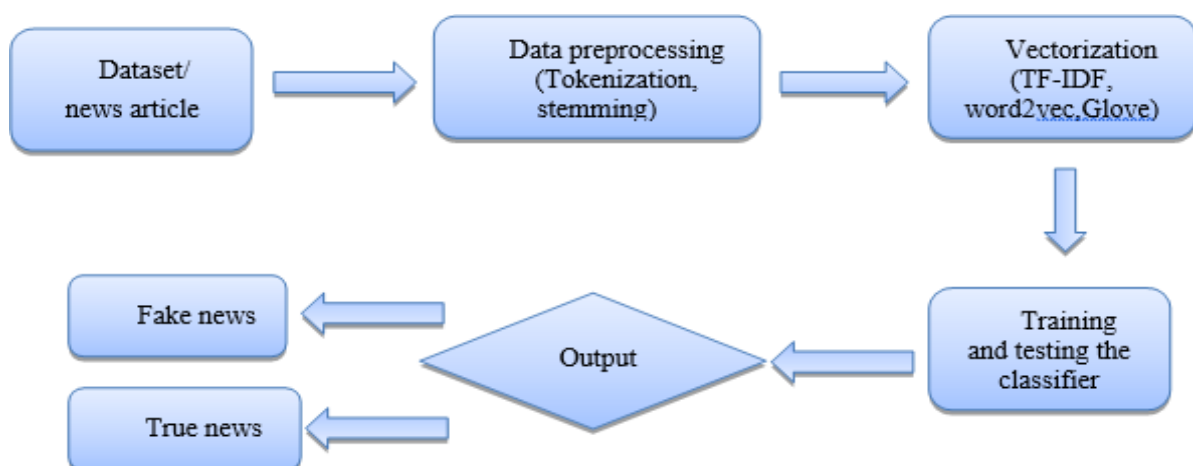

Figure 5: General Framework of the Fake news Detection system

- The next process involves data preprocessing to convert raw data into a clean dataset for making analysis easier.
- Once the dataset is cleaned and ready, the text is converted to numerical sequence or feature vector. Then word embedding is done which is a learnt text representation in which words with related meanings are represented similarly. Word2Vec, one-hot encoding, GloVe, term frequency-inverse document frequency (TF-IDF) etc. are some of the methods that are frequently used for learning a word embedding from text data.
- GloVe embeddings perform better on some data sets, whereas word2vec embeddings perform better on others. They both do an excellent job of capturing the semantics of analogy, which leads us a long way toward lexical semantics in general.
- Other pretrained embedding like Bert and Robustly Optimized BERT (RoBERTa) [18] are also used. BERT and RoBERTa are transformer-based models for NLP. RoBERTa architecture reduces the pre-training time.
- When the feature vector is complete, it is passed into the trained DL model. The CNN (Convolutional Neural Network) is the most basic model in Machine Learning, although it has the issue of categorization of pictures with varied Positions, Adversarial instances, Coordinate Frame, and other minor limitations such as performance. The other frequently used model is the RNN model, but it suffers with gradient exploding and disappearing problem. Also, it is quite difficult to train an RNN.
- Tanh or Relu cannot handle extremely lengthy sequences when employed as an activation function. To overcome these limitations, Researchers use LSTM. LSTMs were developed to address the issue of vanishing gradients that might arise while training a regular RNN.

Once the model is ready, it will then be evaluated on various performance matrices. There are a set of performance evaluation metrics that are particularly used for performance evaluation in credibility detection task. I.e., confusion matrix, precision, recall or sensitivity, and F1- Score

Although there are several techniques and methods that have been established in the last decade to counter fake news but there are still several open research issues and challenges. The section below provides various challenges and open areas that need to be catered.

1. **Multilingual:** On the basis of the number of languages considered by the models, the FND model is usually bifurcated as Unilingual and multilingual. Multilingual news as news can be in any language now-a-days. Earlier the news was unilingual and detection for fake news was a bit easier.
2. **Early detection:** No early detection of news, it takes almost a month to detect fake news which is very challenging.
3. **Quick and real-time:** The finding of the source in real time is important for con-trolling the feast of ambiguous information and reducing the negative effect on society.
4. **Real-time data collection:** It is challenging to collect real-time data, automate rumor detection, and track down the original source. Information pollution, fake news, rumors, disinformation, and insinuation have emerged as a byproduct of the digital communication environment, proving to be extremely destructive
5. **Other Challenges:** Fake news spreading across various languages and platforms, sophisticated and dynamic network architectures, large amounts of unlabeled real-time data, and early identification of rumors are just a few of the perplexing difficulties that have yet to be addressed and warrant additional exploration Improving the credibility and future of the online information ecosystem is a shared responsibility of the social community.

8. CONCLUSION

Social media have pressed the capability to change information at a much bigger pace, to a far broader audience than ever before. This information is not always veracious, because anyone can broadcast anything on the Internet. The existing approaches used machine learning techniques. But with the amount of data available the trend has shifted to deep learning-based detection approaches as these are very efficient in extracting the features from huge data. Various deep learning techniques are used for this purpose which includes CNN, RNN and LSTM. The CNN and RNN networks particularly are used significantly in commuter vision and NLP tasks respectively. Variants of RNN i.e., LSTM, GRU and other gated networks are also widely used and are proven to be must efficient. For the embedding of data, many techniques like word2vec, Glove, TF-IDF, one hot encoding are used. GloVe embeddings perform better on some data sets, whereas word2vec embeddings perform better on others. They both do an excellent job of capturing the semantics of analogy. The paper discusses about some datasets that are

available for fake news detection. Although there are various techniques and methods that have been developed in the last decade to counter fake news but there are still several open research issues and challenges like multilingual, no early detection of news, tempered images, low accuracy, lack of quick & real time discovery etc.

9. REFERENCES

- [1] V. K. Singh, R. Dasgupta, K. Raman, and I. Ghosh, "Automated Fake News Detection Using Linguistic Analysis and Machine Learning Automated Fake News Detection Using Linguistic Analysis and Machine Learning," no. July, 2017, Doi: 10.13140/RG.2.2.16825.67687.
- [2] D. De Beer and M. Mathee, *Approaches to Identify Fake News: A Systematic Literature Review*, no. Macaulay 2018. Springer International Publishing, 2021.
- [3] S. Raza and C. Ding, "Fake news detection based on news content and social contexts: a transformer-based approach," *Int. J. Data Sci. Anal.*, 2021, doi: 10.1007/s41060-021-00302-z.
- [4] C. Caucheteux, A. Gramfort, and J.-R. King, "Disentangling Syntax and Semantics in the Brain with Deep Networks," 2021, [Online]. Available: <http://arxiv.org/abs/2103.01620>.
- [5] K. Nakamura, S. Levy, and W. Y. Wang, "r/Fakeddit: A new multimodal benchmark dataset for fine-grained fake news detection," *Lr. 2020 - 12th Int. Conf. Lang. Resour. Eval. Conf. Proc.*, pp. 6149–6157, 2020.
- [6] X. Z. B, J. Wu, and R. Zafarani, *SAFE: Similarity-Aware Multi-modal Fake*. Springer International Publishing, 2020.
- [7] C. T. Duong, R. Lebet, and K. Aberer, "Multimodal Classification for Analyzing Social Media," 2017, [Online]. Available: <http://arxiv.org/abs/1708.02099>.
- [8] A. Abedalla, A. Al-Sadi, and M. Abdullah, "A closer look at fake news detection: A deep learning perspective," *PervasiveHealth Pervasive Compute. Technol. Healthc.*, no. October, pp. 24–28, 2019, doi: 10.1145/3369114.3369149.
- [9] P. Bahad, P. Saxena, and R. Kamal, "Fake News Detection using Bi-directional LSTM- Recurrent Neural Network," *Procedia Comput. Sci.*, vol. 165, no. 2019, pp. 74–82, 2019, doi: 10.1016/j.procs.2020.01.072.
- [10] J. Zhang, B. Dong, and P. S. Yu, "FAKEDETECTOR: Effective Fake News Detection with Deep Diffusive Neural Network," May 2018, [Online]. Available: <http://arxiv.org/abs/1805.08751>.
- [11] W. H. Bangyal et al., "Detection of Fake News Text Classification on COVID-19 Using Deep Learning Approaches," *Comput. Math. Methods Med.*, vol. 2021, pp. 1–14, Nov. 2021, doi: 10.1155/2021/5514220.
- [12] A. Abedalla, A. Al-Sadi, and M. Abdullah, "A closer look at fake news detection: A deep learning perspective," in *ACM International Conference Proceeding Series*, Oct. 2019, pp. 24–28, doi: 10.1145/3369114.3369149.
- [13] H. H. Sak, A. Senior, and B. Google, "Long Short-Term Memory Recurrent Neural Network Architectures for Large Scale Acoustic Modeling."

- [14] Y. Yang, L. Zheng, J. Zhang, Q. Cui, Z. Li, and P. S. Yu, "TI-CNN: Convolutional Neural Networks for Fake News Detection," 2018, [Online]. Available: <http://arxiv.org/abs/1806.00749>.
- [15] P. Bahad, P. Saxena, and R. Kamal, "Fake News Detection using Bi-directional LSTM-Recurrent Neural Network," in *Procedia Computer Science*, 2019, vol. 165, pp. 74–82, doi: 10.1016/j.procs.2020.01.072.
- [16] I. H. Sarker, "Deep Learning: A Comprehensive Overview on Techniques, Taxonomy, Applications and Research Directions," *SN Comput. Sci.*, vol. 2, no. 6, pp. 1–20, 2021, doi: 10.1007/s42979-021-00815-1.
- [17] M. Education, "The Use of LSTM Neural Network to Detect Fake News on Persian," vol. 12, no. 11, pp. 6658–6668, 2021.
- [18] T. Yesugade, S. Kokate, S. Patil, R. Varma, and S. Pawar, "Fake News Detection using LSTM," pp. 2500–2507, 2021.
- [19] T. Yesugade, S. Kokate, S. Patil, R. Varma, and S. Pawar, "Fake News Detection using LSTM," *Int. Res. J. Eng. Technol.*, 2021, [Online]. Available: www.irjet.net.
- [20] H. Li, H. Wang, and G. Liu, "An Event Correlation Filtering Method for Fake News Detection."
- [21] M. Potthast, "A Stylometric Inquiry into Hyperpartisan and Fake News," no. February, 2017.
- [22] A. M. P. Braşoveanu and R. Andonie, "Semantic Fake News Detection: A Machine Learning Perspective," *Lect. Notes Comput. Sci. (including Subser. Lect. Notes Artif. Intell. Lect. Notes Bioinformatics)*, vol. 11506 LNCS, pp. 656–667, 2019, doi: 10.1007/978-3-030-20521-8_54.
- [23] M. Shrestha, "Detecting Fake News with Sentiment Analysis and Network Metadata," 2018.
- [24] A. A. A. A. Et al., "Detecting Fake News using Machine Learning: A Systematic Literature Review," *Psychol. Educ. J.*, vol. 58, no. 1, pp. 1932–1939, 2021, doi: 10.17762/pae.v58i1.1046.
- [25] A. Drif and S. Giordano, "Fake News Detection Method Based on Text-Features," no.c, pp. 26–31, 2019.
- [26] C. Boididou et al., "Verifying information with multimedia content on twitter: A comparative study of automated approaches," *Multimed. Tools Appl.*, vol. 77, no. 12, pp. 15545–15571, 2018, doi: 10.1007/s11042-017-5132-9.
- [27] "Learning to detect misleading C. Boididou, S. Papadopoulos, L. Apostolidis, and Y. Kompatsiaris, D. content on Twitter," *ICMR 2017 - Proc. 2017 ACM Int. Conf. Multimed. Retr.*, pp. 278–286, 2017, and 10.1145/3078971.3078979, "No Title."
- [28] M. H. Goldani, S. Momtazi, and R. Safabakhsh, "Detecting fake news with capsule neural networks," *Appl. Soft Comput.*, vol. 101, 2021, doi: 10.1016/j.asoc.2020.106991.
- [29] "Declare: Debunking fake news and false claims using K. Popat, S. Mukherjee, A. Yates, and G. Weikum, P. evidence-aware deep learning," *Proc. 2018 Conf. Empir. Methods Nat. Lang. Process. EMNLP 2018*, and doi: 10.18653/v1/d1.-1003 22–32, 2020, "N."
- [30] "Multimodal fusion with recurrent neural networks for rumor Z. Jin, J. Cao, H. Guo, Y. Zhang, and J. Luo, D. detection on microblogs," *MM 2017 - Proc. 2017 ACM Multimed. Conf.*, pp. 795–816, Oct. 2017, and 10.1145/3123266.3123454., "No Title."

- [31] “FANG: Leveraging Social Context for Fake V. H. Nguyen, K. Sugiyama, P. Nakov, and M. Y. Kan, 2020 News Detection Using Graph Representation,” Int. Conf. Inf. Knowl. Manag. Proc., pp. 1165–1174, and D. 10.1145/3340531.3412046., “N.”
- [32] “J. Ma et al., ‘Detecting rumors from microblogs with recurrent neural networks,’IJCAI Int. Jt. Conf. Artif. Intell., vol. 2016-Janua, pp. 3818–3824, 2016.”
- [33] M. Mohsen Sadr, A. M. Chalak, S. Ziaei, and J. Tanha, “The Use of LSTM Neural Network to Detect Fake News on Persian Twitter,” 2021.
- [34] X. Zhou, A. Jain, V. V. Phoha, and R. Zafarani, “Fake News Early Detection,” Digit. Threat. Res. Pract., vol. 1, no. 2, pp. 1–25, 2020, doi: 10.1145/3377478.
- [35] J. P. bots and fake news spreaders at P. Pizarro, profiling fake and PAN’20: bots and gender profiling 2019, news spreaders on T. 2020. I. 2020 I. 7th International, C. on D. S. and A. A. (DSAA), and pp. 626–630 (2020), “No Title.”
- [36] A. D’Ulizia, M. C. Caschera, F. Ferri, and P. Grifoni, “Fake news detection: A survey of evaluation datasets,” PeerJ Comput. Sci., vol. 7, pp. 1–34, 2021, doi: 10.7717/PEERJ- CS.518

