



INTERNATIONAL JOURNAL OF CREATIVE RESEARCH THOUGHTS (IJCRT)

An International Open Access, Peer-reviewed, Refereed Journal

HAND GESTURE CONTROLLED WHEELCHAIR

¹Reshma Anilkumar, ²Amal M R

¹PG Scholar, Department of computer science, st.Albert's college (Autonomous), Ernakulam, Kerala, India

²Assistant Professor, Department of computer science, st.Albert's college (Autonomous), Ernakulam, Kerala, India

Abstract: It is admirable that the ever-growing technology can bring about new changes in the healthcare sector. The persons with disabilities are always facing barriers in accessing the basic services, these barriers can be effectively addressed through advanced technologies like IoT. By taking these possibilities of technology, a wheelchair is developed that will be beneficial to mankind. Here an accelerometer sensor is used, which gives the analog signal according to the tilt of the accelerometer in x (x positive axis, x negative axis) and y (y positive axis, y negative axis) direction and RF module is used to transmit the signal from the transmitter section to receiver section then the movement of the wheel is controlled. Wheelchairs are essential for the elderly and disabled to move from one place to another. But it requires the help of others to control it, and this is where hand gesture-controlled wheelchairs come in handy where it can aid the disabled and control the direction by using simple gesture movements.

Index Terms: IoT, Accelerometer, Analog Signal, RF module, Gesture

I.INTRODUCTION

Disability arises from social attitudes and environmental limits that prevent active interaction and interpersonal communication with others. As per the census 2011, more than 2 crore people are affected by disabilities, which implies that 2.2% of the total Indian population is affected by some form of disability. Apart from this most of the available public infrastructure services are not disable-friendly and a wheelchair-dependent person has to rely on others for their own different needs. Statistics show that the number of people suffering from permanent or temporary disability due to population aging and other non-communicable diseases is increasing day by day. People with disabilities generally face barriers in society to meet basic needs. These barriers can be better addressed by new technologies like IoT. IoT is an indispensable innovation in modern technology. It consists of sensors and electronic devices with various technologies to connect and share data with various systems through communication networks.

The hand is one of the most flexible parts of the human body. It can create more gestures than any other body part. Hand gesture is considered as the most powerful non-verbal communication tool to transfer information between two people. The main concern is how to implement a system that addresses the issue of accessibility for the disabled to their basic needs. This project intends to develop a hand gesture-controlled wheelchair useful for the physically challenged. A person who is dependent on a wheelchair always finds it difficult to move from one place to another on their own choice without the help of others, that is, they always depend on others for their locomotive needs. Gesture controlled wheelchair allows the physically challenged or partially paralyzed person to move as per their desire whenever

they want by using simple hand gestures that control the wheelchair. The proposed system in this project will help them become self-reliant and independent with customizable features to meet their mobility needs.

II.LITERATURE REVIEW

G.Bourhis and K.Moumen in a published paper show that a number of guidance systems are currently available in the market to ensure comfortable navigation for a physically challenged person. The systems developed are highly competitive in bringing change to old traditional systems [1].

Mahipal Manda and B Shankar Babu developed a wheelchair using MEMS technology, can be integrated to develop a useful wheelchair control system using hand movements. Powered wheelchair with high navigational intelligence can be counted as one of the big steps towards integration of physically challenged [2].

Rakhi A. Kalanthri and D. K. Chitra demonstrated in their work that the wheelchair can be controlled in four directions by tilting the acceleration sensor. Ultrasonic sensors are used to control the movement of the wheelchair, avoiding the possibility of collisions with objects until the user is able to take over some of the responsibility of steering. It simply calculates the degree of inclination and decides which direction to move [3].

A study by Kannan Megalingam, Srikanth, and Raj shows that a combination of touch screen and Bluetooth technology allows disabled people to swipe across the screen to control movement. Apart from this, even in situations where the disabled cannot move their arms, a second person can control the movement instead of pushing the wheelchair [4].

The concept developed by Shreedeeep Gangopadhyay ensures that it works completely independently without any wires or restrictions. The ability to avoid obstacles is kept within certain limits from the wheelchair. The wheelchair is configured to turn in a different direction if it detects obstacles while moving [5].

III.NEED OF THE STUDY

Wheelchairs are used by a person with mobility impairments for easy navigation in and out and for other important mobility needs. This device is very useful for the movement from one place to another, especially for old-aged people with difficulty in mobility.

IoT- based wheelchairs have been designed to provide navigation assistance in different ways to the user. The aim of the project is to build a wheelchair having some sort of intelligence, thereby assisting the user in his/her movement. According to the World Health Organization (WHO), only a small percentage of people with disabilities can have access to wheelchairs. Therefore, this project needs to come up with a smart wheelchair that offers many features using the latest components and technologies at a very reasonable cost. Access to mobility equipment is linked to levels of confidence, self-efficacy, and willingness to use technology. Mobility devices can also reduce the social stigma associated with disability by increasing the independence of a person with a mobility impairment. It can also increase access for users who might otherwise be denied access due to security concerns.

Gesture controlled wheelchair has already been built by incorporating additional features such as navigation assistance and motion control using joysticks, touch screens, etc. But they have some common drawbacks. Most of them are not suitable for a person with a limited range of hand movements. It can also cause more strain on the arms. Therefore the proposed system intends to develop a wheelchair with some sort of intelligence, especially focused on the partially paralyzed person to meet their mobility needs and comfort level with customizable features at an affordable cost.

IV.METHODOLOGY

A wheelchair has to be created to control the direction using hand gesture movements. The objective of this project is to develop a smart wheel chair which sense the Gestures of the hand to run the wheelchair. Here two sections are included, one for the transmitter block and other for the receiving block. Both sections need to be designed and implemented separately. Accelerometer is used as the sensor to detect the tilting of the hand, which in turn transmit the signals though the RF modules.

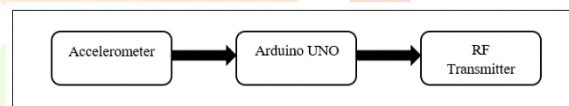

Fig. 1.Transmitter Section

The Fig.1 demonstrate the work flow of transmitter module, where the movement of the hand (Wrist) is sensed using the accelerometer which is the sensor in form of analog signal and send it to the microcontroller of the Arduino. Then the data collected is transmitted in form of Radio frequency signal via, the RF Transmitter module.

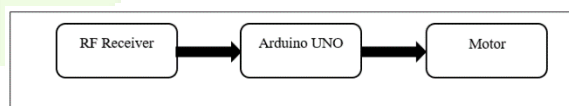

Fig. 2.Receiver Section

The Fig.2 demonstrate the work flow of receiver module, which shows how the direction of the wheelchair is controlled. The data transmitted from the transmitter section is received by the RF receiver module and send to the microcontroller of Arduino in receiver section which gives the desired output by controlling the motor driver(L293D).

V.CIRCUIT DEVELOPMENT

The circuit development represents the proposed wheelchair system. It assembles various circuits together results in schematic representation.

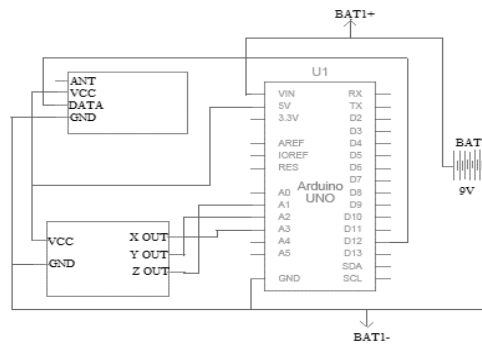

Fig. 3.Circuit Diagram of Transmitter Section

Fig.3 illustrate the circuit development of transmitter section consist of Arduino board, accelerometer, RF transmitter module, and a 9v battery. Accelerometer consist of GND, VCC and x, y, z out pins which is connected to the 5V, GND and A3, A2, A1 pins of the Arduino respectively. Which detect the tilt along the x, y, z axis. RF transmitter module consist of 4 pins such as ANT, VCC, GND, and DAT. DAT (Data) pin is connected to the digital pin 12 of the Arduino, GND and VCC to the respective pins of Arduino.

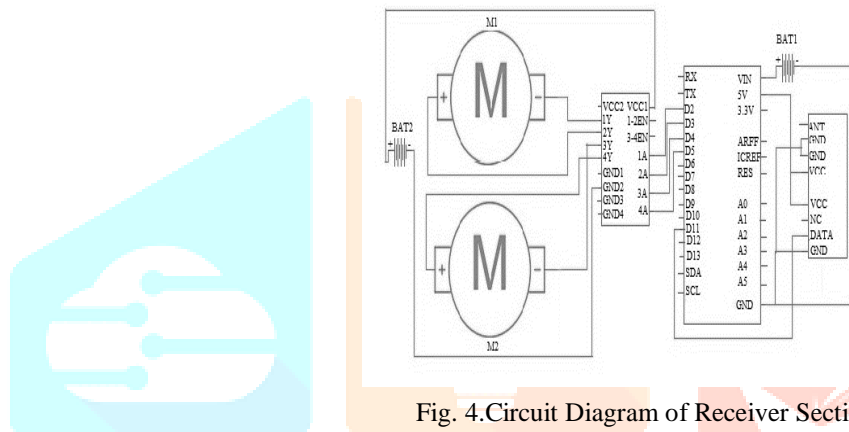

Fig. 4.Circuit Diagram of Receiver Section

Fig.4 illustrate the circuit development of receiver section which consist of an Arduino, RF receiver module, L293D motor module and 9v battery. RF receiver module contain 8 pins. Where DAT pin is connected to the digital pin 11 of Arduino, VCC and GND to the respective pins of the Arduino. For powering the Arduino, a 9v battery is connected to the VIN and GND of the Arduino. The L293D is provided with separate power for the working of the motor.

VI.WORKING

The transmitter section can be placed on the wrist like a wearable device. When a forward tilting is detected from adxl335 as analog signal the character ‘f’ is transmitted to the micro controller of Arduino in receiver section through RF pair modules, and the motor driver will control the movement of the wheel in forward direction i.e., both the m1 and m3 pin of the motor are set as HIGH and rest as LOW. When the character ‘b’ is transmitted over the RF module as a result of backward tilting of the wrist the motor driver will control the movement in backward direction. Similarly the right and left tilting will control the movement in right and left direction.

Based on the difference in initial value and real-time value read by accelerometer it determines which direction the wrist is moved. Only Acceleration along x and y axis are considered for determining the direction. When the tilt is in forward direction along the x axis the value of x decreases otherwise value increases and when tilting is along the y axis in forward direction the value of y decreases otherwise increases.

Table. 1.Working direction of wheelchair

Hand Direction	Left Motor	Right Motor
Forward	Forward	Forward
Backward	Backward	Backward
Left	Stop	Forward
Right	Forward	Stop

When both the wheels of wheelchair move in forward direction the wheelchair moves forward. When both wheels move backward the wheelchair moves in backward direction. Wheelchair moves in left direction when the left wheel stops and right wheel move forward and to right direction when the right wheel stops and left wheel moves forward.

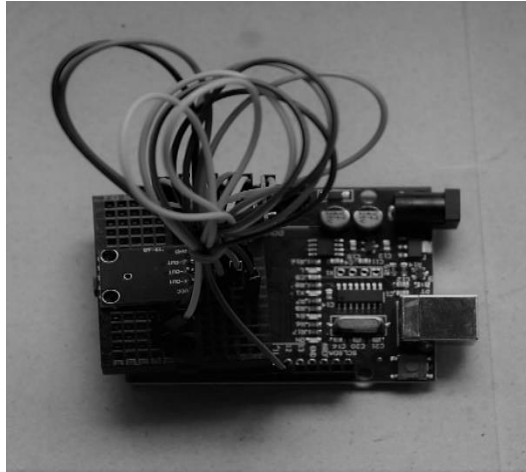

Fig. 5. Prototype of Transmitter Section

The Fig.5 shows the hardware connection of the transmitter section, consist of Arduino UNO, adxl335(accelerometer), RF transmitter module, and power supply. This connection will be placed on the wrist like a wearable device. The circuit operate when it gets signal from accelerometer according to the tilt.

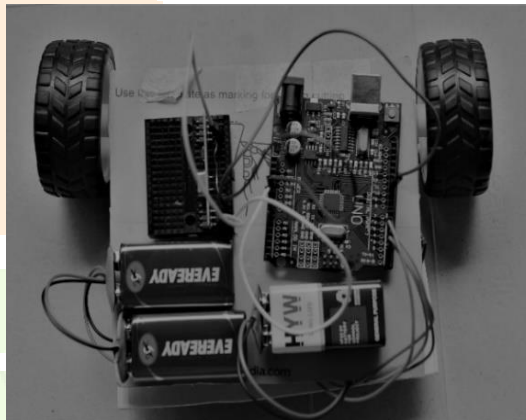

Fig. 6. Prototype of Receiver Section

The Fig.6 shows hardware connection of receiver section, consist of Arduino UNO, RF Receiver module, L293D motor driver, motors and power supply. The circuit works when the RF receiver module receive the radio frequency signal from the RF transmitter module.

VII.SCOPE OF STUDY

A manual gesture-controlled wheelchair has the potential to bridge the gap between humans and machines. In addition, these hand gesture signals can be changed or advanced into speech and brain signal recognition, becoming a milestone in helping people with total paralysis. We can further improve this by making wheelchairs more cost-effective and offering higher possibilities with various sensors and wireless remotes, thus making the system more robust. Features such as head movement detection and eye retina movement detection can also be incorporated using optical sensors to control the direction of the wheelchair. Also, various safety measures can be installed in the wheelchair, such as tracking systems to track the wheelchair and its user, and a GSM system to receive important and urgent messages from wheelchair users.

VIII.CONCLUSION

This paper describes the basic concepts of a hand gesture-controlled wheelchair using an accelerometer as the sensor that detects hand movement and controls the direction of the wheelchair. In this project we have discussed the major obstacles faced by disabled people in performing various activities to fulfil their basic needs. Hand gesture recognition systems are gaining importance in user interfaces as they provide more convenience. The wheelchair's proposed design paves the way for motion control using embedded hardware-controlled devices, and the results of the proposed system show it is effective and competitive in performance, accuracy and efficiency.

IX. REFERENCES

- [1] Bourhis, G., Moumen, K., Pino, P., Rohmer, S., & Pruski, A. (2002). *Assisted navigation for a powered wheelchair*. IEEE Xplore. Retrieved November 4, 2022, from <https://ieeexplore.ieee.org/document/385072>.
- [2] Mahipal Manda, B Shankar Babu, M Abhishek, & J Srikanth. (2018, September). *HAND GESTURES CONTROLLED WHEELCHAIR*. <https://www.jetir.org/papers/JETIRE006094.pdf>.
- [3] Kalantri, R. A., & Chitre, D. K. (2013, August). *Automatic Wheelchair using Gesture Recognition*. www.ijeat.org. Retrieved November 4, 2022.
- [4] Megalingam, R. K., Sreekanth, S., A, G., Teja, C. R., & Raj, A. (2017, January). *Wireless gesture controlled wheelchair*. IEEE Xplore. Retrieved November 4, 2022, from <https://ieeexplore.ieee.org/document/8014621>.
- [5] Shreedeeep Gangopadhyay, Somsubhra Mukherjee & Soumya Chatterjee. (2013, September). *Intelligent gesture controlled wireless wheelchair for the physically handicapped* - iraj. Retrieved October 9, 2022, from http://iraj.in/journal/journal_file/journal_pdf/1-7-139029269940-45.pdf.
- [6] Mahmood, M., Rizwan, M. F., Sultana, M., & Imam, M. H. (2020, June 7). *Design of a low-cost hand gesture controlled automated wheelchair*. IEEE Xplore. Retrieved November 4, 2022, from <https://ieeexplore.ieee.org/document/9230849>.
- [7] Francis, J., & Kadan, A. B. (2014, August). *Significance of hand gesture recognition systems in vehicular automation-A survey*. IJCA. Retrieved November 4, 2022, from <https://www.ijcaonline.org/archives/volume99/number7/17389-7931>.
- [8] John, F., Shaju, J., Mathai, M. K., & Seby, M. (2019, November 3). *Gesture controlled wheelchair*. Journal of Embedded Systems and Processing. Retrieved November 4, 2022, from <http://matjournals.in/index.php/JoESP/article/view/4419>.
- [9] Noman, A. T., Rashid, H., Khan, M. S., & Islam, M. E. (2018, October). *A new design approach for gesture controlled smart wheelchair utilizing microcontroller*. IEEE Xplore. Retrieved November 4, 2022, from <https://ieeexplore.ieee.org/document/8745607>.

