



# REVIEW ON IDENTIFICATION, EXTRACTION AND PURIFICATION TECHNIQUES OF HERBAL DRUGS.

M.G.Shinde,S.k.Bais,R.A.Gangthade \*

Fabtech college of pharmacy sangola,Dist-Solapur -413307

## ABSTRACT

People are growing more interested in herbal medicines today because of their numerous advantages. Herbal formulations are now widely recognised as successful therapies for a variety of diseases. More than 80% of the world's population relies on herbal goods and medications to maintain a healthy lifestyle, even if the majority of these usage are unusual. An surge in the use of herbal products has also resulted in a number of product abuses and adulterations, which have disappointed buyers and suppliers and, in some cases, had disastrous outcomes. The development of trustworthy analytical methods that can quantitatively analyse marker/bioactive compounds, other essential elements, and correctly profile the phytochemical composition presents considerable challenges for scientists. Standardization is a crucial stage for the establishment.

**Key Words:** Authentication, Chromatography, Extraction, Purification, Standardization, Herbal technology, Herbal medicine.

## Objective:

Recognize the various approaches utilised in advanced herbal medication technology.

## Introduction:

The core concepts underlying the widely used herbal technology are covered in this article. Except for Allopathy , all of India's officially recognised medical practises, including Ayurveda, Yoga, Unani, Siddha, Homeopathy, and Naturopathy, mainly rely on herbal remedies. Every day, millions of Indians use herbal medicines as spices, DIY remedies, health foods, over-the-counter (OTC) drugs for selfmedication, or drugs supplied by non-allopathic systems . Herbal medicines have grown exponentially in popularity over the past several years in both emerging and developed countries due to their natural origins and absence of negative effects.

Herbal medicines are the result of years of therapeutic trial and error by practitioners of traditional systems of medicine.(1) ( The market for natural products has grown, and interest inThe need for alternative treatments has expanded globally, which has boosted the use of conventional medical systems. Herbal drug technology is used to turn botanical materials into medications, and standardisation and quality control with the proper integration of modern scientific techniques and traditional knowledge are essential.(2)

• The methods of identification include the following.

### (a) Expert Determination

Expert judgement is the most trustworthy method of identification in terms of reliability or correctness. The relevant group has typically been treated by specialists (monographs, revisions, synopses), and it is likely that the more recent floras or manuals incorporate the experts' taxonomic ideas. Botanical gardens, herbaria, museums, colleges, and universities are typically where you can locate experts. Although this procedure is very reliable, there are some drawbacks, such as the requirement for professionals to spend their valuable time on it and identification delays.

### b) Recognition

It is almost as trustworthy as professional judgement. The reason for this is the identifier's substantial prior experience with the pertinent plant group. In certain groups, this is practically impossible.

### (c) Comparison:

A third method involves contrasting an unknown with samples, images, drawings, or descriptions that are known. Despite being a dependable process, it could be extremely time-consuming or even impossible because there aren't enough equivalent materials. Naturally, the accuracy and dependability of the used samples, drawings, or descriptions determine how reliable the comparability .

### D) The Use of Keys and Related Instruments (Synopses, Outlines, etc.):

Due to the fact that it doesn't require the resources, time, or knowledge required for comparison and recognition, this method is by far the most popular.

## AUTHENTICATION OF PLANT

The proper plant species and parts are used as raw materials for herbal products thanks to a quality control process called herbal authenticity (3)

### Authentication of Herbal Drugs:

The building blocks for making a botanical product are authentic raw ingredients. Moreover, each stage of harvest, storage, processing, and formulation has the potential to substantially alter the final product's quality and consistency. Procedures to provide quality control in manufacture and storage are crucial tools because the best efficacy and safety of these commodities must be guaranteed. The evaluation of pharmacological, toxicological, or clinical studies using botanical substances also requires these check.

#### 1) Taxonomic method

The first stage of identifying and authenticating botanical materials requires using traditional botanical procedures to gather and record the plant at its source. Using this technique, it is possible to pinpoint the drug's botanical source and ascertain its scientific Latin binomial designation (i.e., genus or species). It is the initial phase of authentication. Before authenticity, the necessary prerequisites always include information such as the botanical name, vernacular names, location of the plant material collection, collector's information, habitat, season of collection, altitude, and parts collected, among others.

## 2) Herbarium Voucher Sample

For reference in the future, the sample of material should be preserved as a voucher sample in a herbarium or research facility.

## 3) Macroscopic method

The macroscopic identification of botanical materials is determined by factors such as shape, size, colour, texture, surface features, fracture characteristics, odour, taste, and other organoleptic aspects that are contrasted with a standard reference material.

## 4) Microscopic method

The structural, cellular, and interior tissue characteristics of botanicals are ascertained using microscopy. It is typically used to distinguish between two herbals that are identical and to identify them. This method is frequently employed since it is practical, quick, and applicable to exclusive drugs. Star anise is an illustration of a plant that may be identified with the help of microscopic methods (*Illicium verum* Hook.f). Star anise, as its name suggests, is a fruit with a star shape and an anise flavour that was once only found in southern China but has since spread to all of Eastern Asia's tropical and subtropical regions. In China and India, the fruit is mostly used to flavour foods and confections as a fragrant spice. It is wellknown for its healing capabilities in Rheumatism, back pain, and hernias are all treated using traditional Chinese medicine. Unfortunately, there are more and more instances of newborns in western nations like the United States who experience severe neurological symptoms like seizures, vomiting, and fast eye movement. 4)

## Physicochemical methods

Total ash, water soluble ash, acid insoluble ash, and sulfated ash are among the parameters. The identification of the particular pharmaceuticals or proprietary medicines can be determined by comparing these values to the normative values of the Indian pharmacopoeia.(4)

## EXTRACTION

The process of extracting medicinal plants involves separating active plant components or secondary metabolites such alkaloids, flavonoids, terpenes, saponins, steroids, and glycosides from inert or inactive material using a suitable solvent and accepted extraction techniques.

## Different extraction method

Commonly used methods in the extraction of medicinal plants

- (i) Maceration
- (ii) Infusion
- (iii) Digestion
- (iv) Decoction
- (v) Percolation
- (vi) Soxhlet extraction
- (vii) Microwave-assisted extraction
- (viii) Ultrasound-assisted extraction

### 1. Maceration

Whole or coarsely crushed plant material is kept in contact with the solvent in a sealed container during the maceration process (for fluid extract) for a predetermined period of time with regular stirring until soluble material dissolves. This method functions better with drugs that are thermolabile (6)

### 2. Decoction

To remove the water-soluble and heat-stable components, the crude drug is cooked in water for 15 minutes, cooled, filtered, and then sufficiently cold water is run through it to produce the necessary volume [4].

### 3. Infusion

It is a diluted solution made up of the easily soluble components of crude medications. Fresh infusions can be created by briefly macerating the particles in either cold or boiling water [4].

### 4. Digestion

In Digestion Light heating is employed in this sort of maceration to facilitate the extraction procedure. It is used when a moderately high temperature is allowed since it improves the menstrual fluid's ability to act as a solvent [4].

### 5. Percolation

This is the technique most usually used to extract active ingredients for tinctures and fluid extracts. A percolator—a narrow, conical vessel open at both ends—is typically used. The specified amount of menstruum is soaked into the dry components for roughly 4 hours in a container that is tightly sealed before the mass is packed and the percolator's lid is shut. More menstrual fluid is added to the mixture to create a thin film over the bulk, which is then allowed to macerate for a period of time.

### 6. Sonication

Utilizing ultrasound at frequencies between 20 kHz to 2000 kHz throughout the procedure results in cavitation by increasing the permeability of cell walls. The technique works well in certain circumstances, like when extracting rauwolfia roots, but the greater costs prevent it from being used widely. The procedure's occasional but known negative impact of ultrasound energy (greater than 20 kHz) on the therapeutic ingredients is a drawback.

due to the production of free radicals in plants, medication molecules can undergo unfavourable modifications (6)

### Supercritical fluid extraction

Since the late 19th century, several chemical compounds have been extracted using supercritical fluid technology. It typically uses CO<sub>2</sub> as the mobile phase and pressurises the entire chromatographic flow path. When a fluid's pressure and temperature are above their respective critical values, it is said to be supercritical (T<sub>c</sub>- critical temperature and P<sub>c</sub>-critical pressure). The critical point is at the right upper end of the phase diagram, and the region beyond it is known as the supercritical zone. It is not above the T<sub>c</sub>.

it is feasible to liquefy a gas by putting it under more pressure. In other words, a supercritical fluid might act like a gas or a liquid but is truly neither. These are a supercritical fluid's distinguishing qualities.

viscosity, density, and diffusivity [6]. The portions of the curve that correspond to the gas, liquid, and solid states are defined. The vapor-liquid coexistence curve ends at the critical point. No phase transition occurs at the critical temperature, meaning that no matter how much pressure is applied, the fluid cannot change from a gaseous state to a liquid state. There is only one phase in the supercritical environment, which is described as neither a gas nor a liquid and possesses physical and thermal characteristics halfway between those of a pure liquid and a solid(7)

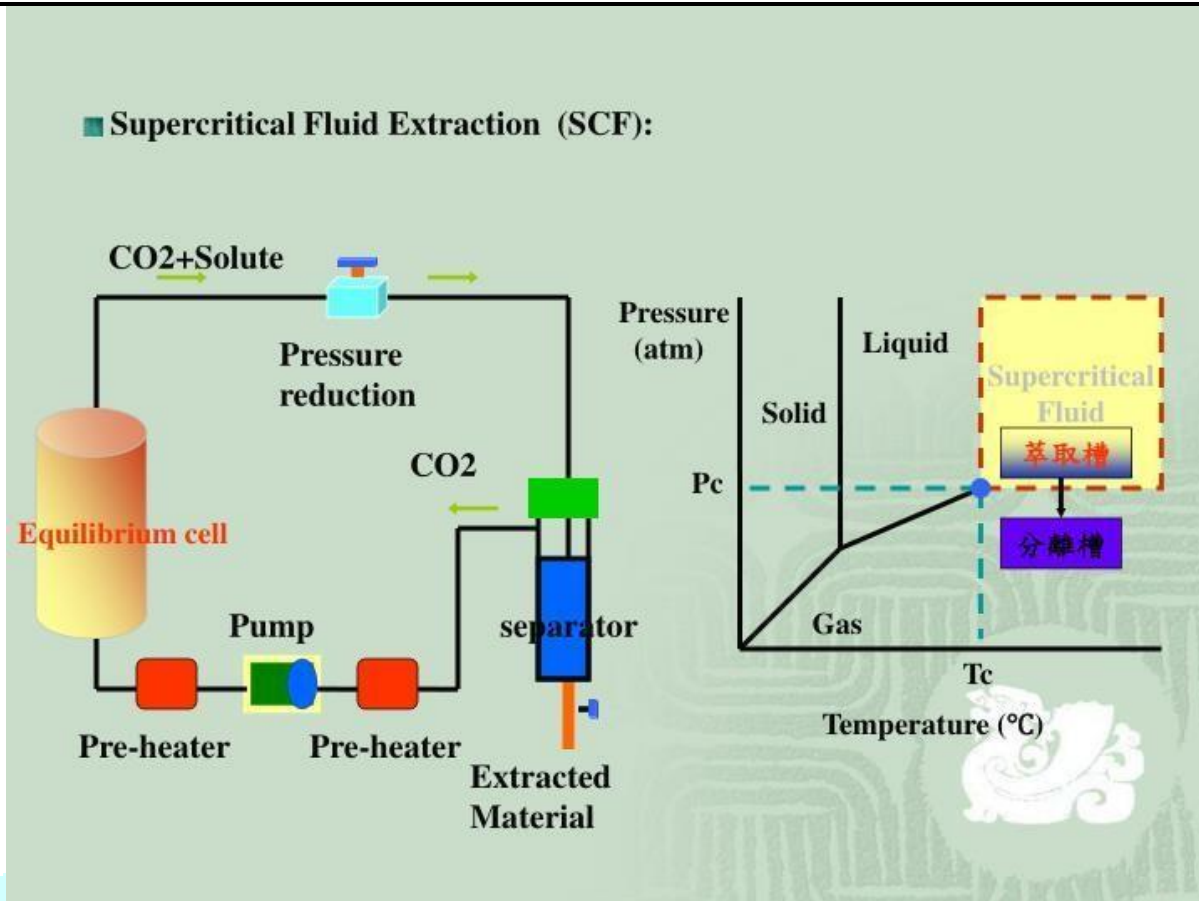

### Microwave-assisted extraction

This is one of the more sophisticated extraction techniques used to prepare medicinal herbs. The method makes use of an ionic transfer mechanism and dipole rotation to displace charged ions from the solvent and drug material. This technique works well for flavonoid extraction. Electromagnetic radiation with frequencies between 300 MHz and 300 GHz and wavelengths between 1 cm and 1 m is used in this process.] Energy produced by the microwaves at a frequency of 2450 Hz ranged between 600 and 700 W. The method bombards an object with microwave radiation, which can absorb electromagnetic energy and turn it into heat. The heat created as a result makes it easier for the solvent to enter the drug matrix. Using a polar solvent causes ion dipole rotation and migration. Improve the penetration of the solvent and aid in the extraction process. The use of nonpolar solvents is not recommended by this method since the microwave radiation that is released when one is utilised will only generate very little heat(7)

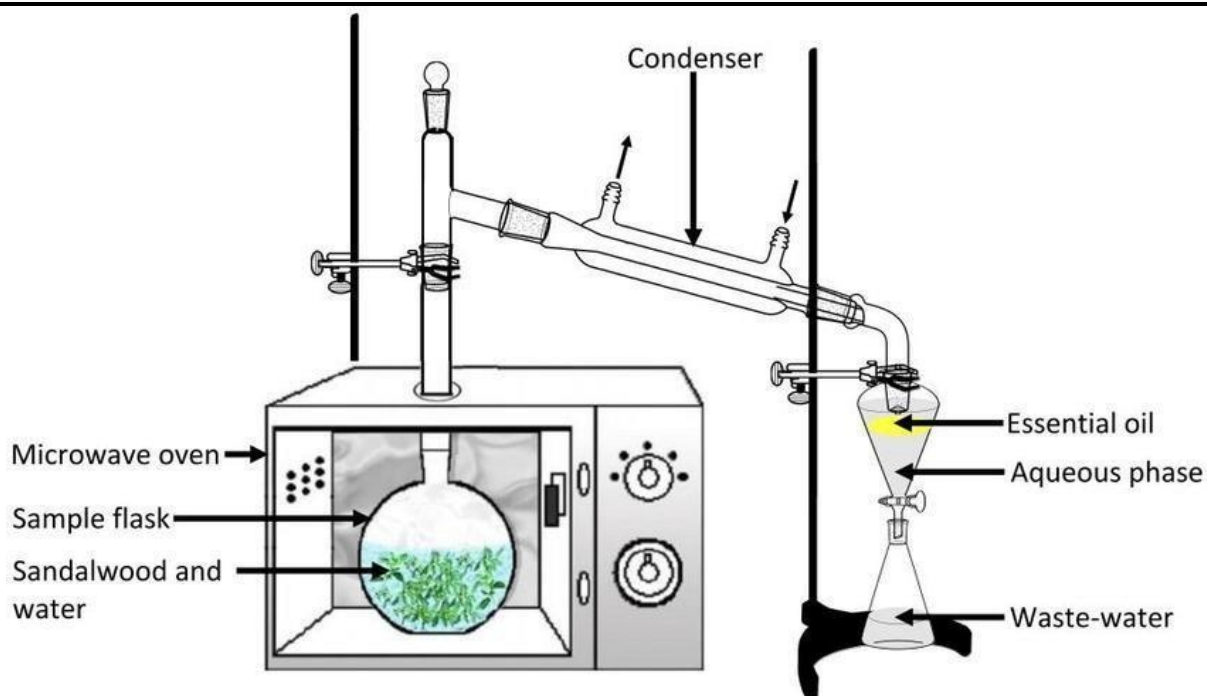

#### • Ultrasound-assisted extraction.

In order to damage plant cell walls and enhance the drug surface area for solvent penetration, this procedure applies sound energy at very high frequencies, greater than 20 KHz. Secondary metabolites will consequently be released. In this procedure, plant material must first be dried before being ground into fine powder and properly sieved. After mixing the prepared sample with the proper extraction solvent, it is loaded into the ultrasonic extractor. The high sound energy applied speeds up extraction by lowering the need for heat(7)

#### Advantages:

Ultrasound-assisted extraction can be utilised on small samples; it maximises yield while cutting down on extraction time and solvent use.

#### Disadvantages

It is challenging to duplicate this technique, because using a lot of energy may destroy the phytochemical by creating free radicals (7)

#### Solid Phase Extraction

Depending on the components' needs, solid phase extraction is a sample preparation technique used for component isolation, enrichment, and purification from aqueous solutions. Qualities that are chemical and physical. A solid phase or sorbent is used to contact aqueous samples in this process, where the substance is adsorbed on the surface of the solid phase before being eluted. In comparison to the amount of analysis in the sample, the extract amount is insignificant. Analytical laboratories frequently utilise solid phase extraction. Additionally, it solves problems with the liquid-liquid extraction process, such as unsatisfactory phase separation, low recovery, and excessive organic solvent waste. In addition, costly glassware is required for liquid-liquid extraction. A substance known as a sorbent is used to adsorb or absorb various fluids. Different Packing Types for Solid Phase Extraction Based on the particle size, packing is utilised in solid phase extraction(8)

## Steps involved in Solid Phase Extraction

The Solid Phase Extraction Operation is divided into five steps as follows:

Step 1: Wetting of Sorbent.

Step 2: Conditioning of sorbent.

Step 3: Loading of sample.

Step 4: Interference Elution.

Step 5: Analytic Elution(8)

## ISOLATION AND PURIFICATION OF TECHNIQUES

General isolation technique :

1)Chromatographic techniques 2)spectroscopic techniques

techniques utilised to determine the properties of the isolated chemicals. The first step in developing drugs for potential novel treatments for human ailments is the identification and isolation of bioactive components from herbal extracts(9)

The ingredients in the extracts from the aforementioned procedures are a complicated mixture that include numerous types of natural compounds with distinct polarity. pure bioactive materials chemical need additional separating and purifying. The process of identifying and characterising pure bioactive natural products still faces significant challenges regarding their separation.

product. Natural product purification and separation have recently experienced new development [28]. By isolating and purifying a large number of bioactive natural compounds,2)spectroscopic technique utilising several methods of separation, including TLC, HPTLC, paper chromatography, column chromatography, gas chromatography, OPLC, and HPLC. Due to their practicality, affordability, and effectiveness, thin-layer chromatography

(TLC) and column (10)

### • Chromatographic techniques

The most adaptable and easily accessible separation method is chromatography. Chromatography is a process that uses a stationary phase and a mobile phase to separate and identify different parts of substances, mixtures, or components. Many chromatographic techniques are used to separate and purify plant components. It takes a complex system of mixes to make herbal medication. Therefore, the preferred methods for identifying "botanical drugs" are primarily designed to obtain a distinctive fingerprint of a particular plant that indicates the presence of a specific quality-defining chemical element. For the aim of quality control of herbal medicines, chemical fingerprints created using chromatographic techniques, notably hyphenated chromatography, are highly advised because they may accurately depict the "chemical integrities" of the herbal medicines. be utilised to authenticate and identify herbal goods as a result(11)

### Herbal drugs chromatographic techniques –

- Thin layer chromatography (TLC)
- High performance liquid chromatography (HPLC)
- Ultra-high performance liquid chromatography
- Hydrophilic interaction chromatography (HILIC)
- Gas chromatography (GC)
- Two-dimensional (2D) chromatography(12)

## THIN-LAYER CHROMATOGRAPHY

**Principle:**

Principle of Thin Layer Chromatography Thin-layer chromatography (TLC), like other chromatographic methods, is based on the separation principle. The relative affinity of chemicals for the two phases is what drives the separation. The substances in the mobile phase pass over the stationary phase's surface. The compounds that have a stronger attraction for the stationary phase move slowly whereas the other compounds move quickly during the movement. As a result, the mixture is successfully separated. The mixture's distinct components emerge as spots at the end of the separating procedure. Respective levels on the plates. Their character and nature are identified by suitable detection techniques.

**Components of Thin Layer Chromatography (TLC) • TLC plates:**

preferably ready made with a stationary phase: These are stable and chemically inert plates, where a thin layer of stationary phase is applied on its whole surface layer. The stationary phase on the plates is of uniform thickness and is in a fine particle size. • **TLC Chamber**

This is used for the development of TLC plate. The chamber maintains a uniform environment inside for proper development of spots. It also prevents the evaporation of solvents and keeps the process dust free.

• **Mobile phase:**

This comprises of a solvent or solvent mixture The mobile phase used should be particulate-free and of the highest purity for proper development of TLC spots. The solvents recommended are chemically inert with the sample, a stationary phase. • **A filter paper:**

This is moistened in the mobile phase, to be placed inside the chamber. This helps develop a uniform rise in a mobile phase over the length of the stationary phases.

## Thin Layer Chromatography (TLC)

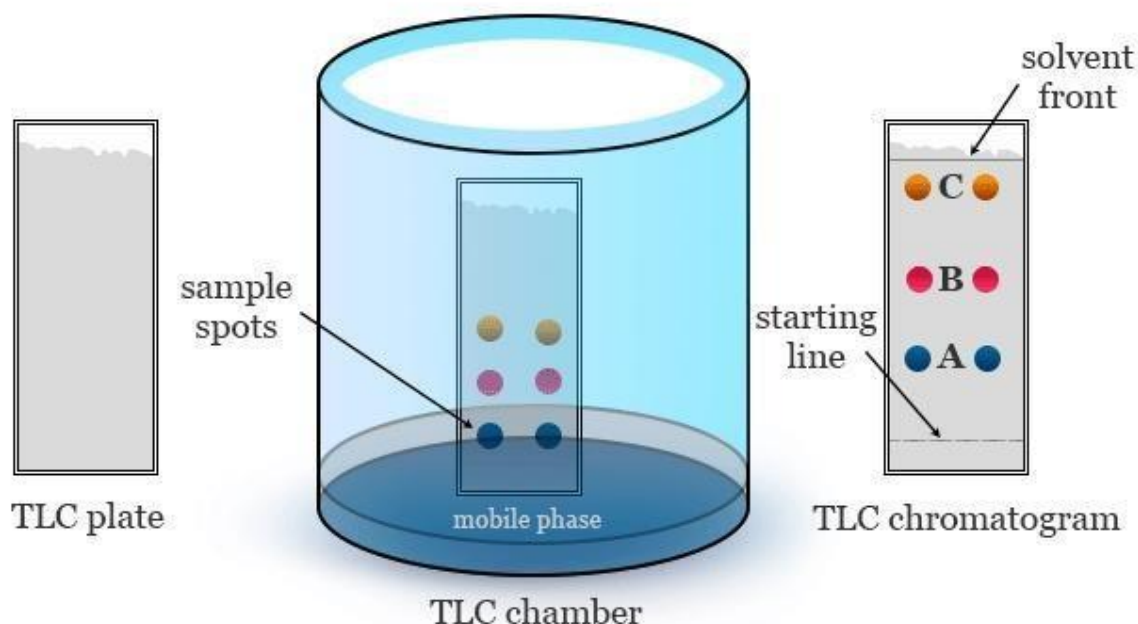

Priyamstudycentre.com



## APPLICATIONS OF TLC

1. TLC used in wide variety of industry and research
2. Testing and quality control of pharmaceutical formulation
3. Examination of antibiotic and drug residues in food.

### Column Chromatography

The process of column chromatography Each of these distinctive components can be isolated using chromatographic techniques since proteins differ in their size, shape, net charge, stationary phase utilised, and binding ability. The most common application of these techniques is column chromatography. Using this method, biomolecules can be made pure. The material to be separated is put to a column first (stationary phase), followed by wash buffer (mobile phase). Their flow via the inside column material, which is supported by fibreglass, is ensured. The samples are gathered at the device's base in a volume- and time-dependent way.

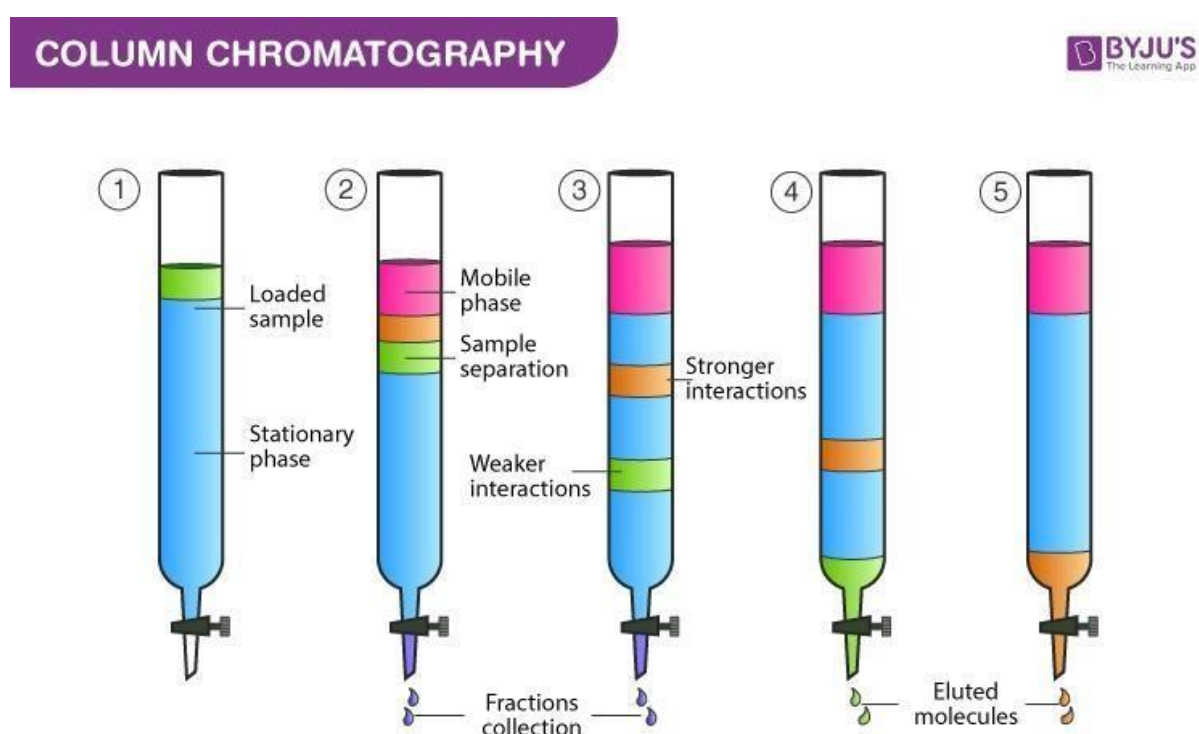

### High Performance Thin Layer Chromatography

The pharmaceutical industry regularly makes use of the HPTLC technology for process development, adulterant identification and detection in herbal products, as well as for figuring out whether mycotoxins and pesticides are present and for quality control of medical herbs and foods. Numerous studies have shown that running multiple samples simultaneously is possible when using less mobile phase than in HPLC. Additionally, mobile phases with a pH of 8 or higher have been said to work with HPTLC. The pharmaceutical industry regularly makes use of the HPTLC technology for process development, adulterant identification and detection in herbal products, as well as for figuring out whether mycotoxins and pesticides are present and for quality control of medical herbs and foods. Numerous studies have shown that running multiple samples simultaneously is possible when using less mobile phase than in HPLC. Additionally, it has been reported that mobile phases with a pH of 8 or above are compatible with HPTLC.

## High Performance liquid chromatography

1) In analytical HPLC, the crucial factors to be taken into account are resolution, sensitivity, and quick analysis times, while in preparative HPLC, the crucial factors to be taken into account are throughput or recovery as well as the level of solute purity. Larger stainless-steel columns and packing materials (particle size 1030 m) are required for preparative HPLC (pressure >20 bar). Examples of silica columns in normal phase include Bromanil 10 m, kormas 16 m, and Choralcelo AS 20 m, while those in reverse phase include kormas C18, kormas C8, and YMC C18. Compounds are to be isolated or purified, but in analytical work, information about the sample is what is sought after. This is crucial in the modern pharmaceutical sector, because novel products—natural and synthetic—must be released onto the market as soon as feasible. (11)

## Purification technique for isolated phytoconstituent.

The process of isolating the components of plant extracts or useful sections one at a time and purifying them into monomer compounds using physical and chemical processes is known as the separation of phytochemicals. Solvent extraction, precipitation, crystallisation, fractional distillation, salting-out, and dialysis are some of the traditional isolation techniques still in use today. The separation of phytochemicals, however, also benefits from the use of contemporary separation techniques such as high performance liquid chromatography, ultrafiltration, and high performance liquid drop countercurrent chromatography. The common techniques and their unique applications for isolating phytochemicals are described in this section.

### Solvent technique

#### • Acid and basic solvent method

When using the acid and basic solvent method, care should be taken to consider the strength of the acidity or alkalinity, the contact time with the separated components, the heating temperature, and time, in order to prevent structural changes of some compounds under harsh conditions or the inability of the chemical structures to be returned to their original States.

#### • Polarity gradient extraction method

Using this technique, the separation goal is accomplished based on the various polarities of the various plant extract constituents and the various partition coefficients in twophase solvents. The polarity of the components in plant extracts is typically taken into account when choosing between different two-phase solvent systems. For instance, the n-butanol-water system can separate the components with strong polarity from the ones with medium polarity. can be separated using an ethyl acetate-water system, while a chloroform-water system can be used to separate components with weak polarity.

#### • Precipitation method

It is a technique that relies on the creation of some phytochemicals as precipitates through reactions with particular reagents, or the precipitation of some components from solutions through the addition of particular reagents, which can lessen the solubility of some components in solutions. If the target components are necessary for the formation of precipitation, the precipitation process must be reversible.

- **Different techniques of characterization of bioactive constituents-**

- 1) Standard isolation methods
- 2) Methods of extraction
- 3) The separation of natural plant components requires the extraction of plant material as a key step. and their cleansing.
- 4) Plant matrices naturally contain a variety of chemicals with different physical and chemical properties, making them complicated in nature [8].
- 5) Therefore, it is essential to thoroughly separate plant matrices from the rest of the organism and generate pure molecules that are of interest to plants in order to characterise them.
- 6) Extraction techniques can be divided into various categories [9].
- 7) They have been divided into groups in this chapter according to the temperatures they operate in.  
Methods for Low or Room Temperature
- 8) The cold extraction technique. The procedure has been written about in the literature. Briefly, samples of dried plant components (chopped, crushed) (13)

- **Drug for advance technology :**

### **SHANKPUSHPI (CONVOLVULUS PLURICAULIS)**

The powerful memory enhancer and brain tonic known as Shankpushpi—also known by the names Shankhini, Kambumalini, Shankpushpi, Sadaphuli, and Sankhaphuli—actively works to increase intelligence and brain function. The plant was given the name shankpushpi because of its shankh or conch-shaped blooms. Additionally, it aids in improving focus, learning capacities, mental tiredness, sleeplessness, tension, anxiety, and depression, among other things. Due to its antidepressant effect, it enhances mental wellness and could assist in controlling depression.

Ayurveda claims that Shankpushpi relieves anxiety and tension by calming the brain. Its Medhya (improves intelligence) characteristic also helps memory by functioning as a brain tonic. Take Shankpushpi powder with warm milk or water to assist improve focus and memory. Additionally, shankpushpi pills and capsules can enhance cognitive abilities. Ayurvedic Shankpushpi Syrup is a memory and mental acuity enhancer. It helps with mental acuity issues, forgetfulness, memory loss, poor recall, etc. However, medications or supplements can only enhance alertness, attention span, brain functioning, nerve coordination, and the capacity of the brain to retain information; they may not be able to alter your procrastinating patterns. Daily brain exercises are therefore necessary to improve cognitive capacities. capabilities. Shankpushpi has the status of a nerve tonic in Ayurveda. Because of this Daily brain exercises are therefore necessary to improve cognitive capacities. capabilities. Shankpushpi has the status of a nerve tonic in Ayurveda. It contains substances including tryptanoids, flavonol glycosides, anthocyanins, and steroids, for example(13)

### **Conclusion**

Plants, herbs, and ethnobotanicals have been utilised for health promotion and disease treatment since the dawn of humans and are being used today in many parts of the world. The foundation of contemporary medicine today is made up of plants and other natural resources, which also significantly influence how commercial drug preparations are made today. Around 25% of medicines given globally are made from plants. However, plants are frequently employed in healthcare rather than pharmaceuticals. Some people prefer using herbal remedies as a form of medicine. Others utilise herbs as a complementary therapy to traditional medications. However, the only accessible or inexpensive form of healthcare in many

underdeveloped nations is traditional medicine, of which herbal medicine is a vital component. No matter the reason, folks who use herbal remedies should be confident that the goods they purchase are secure and contain what they claim to, whether it is a specific herb or a specified quantity of a specific herbal component. Sciencebased information on dose, contraindications, and efficacy should also be provided to consumers. Global legal harmonisation is required to do this in order to direct the ethical production and distribution of herbal medicines. If there is enough scientific evidence to support the use of a herb, then proper legislation should permit its promotion in order to reap the benefits for the improvement of public health and the treatment of disease.

## Reference

- 1]Parul Agarwal ,Shashi Alok , Amreen Fatima And Amita Verma. Current Scenario Of Herbal Technology Worldwide ,International journal of pharmaceutical science and research ,Vol.4,Issue 11.(2013).
- [2]Bande Nilam Pralhad ,Gowekar Narendra. Recent Trends In Herbal Drugs. Journal of Emerging technologies and enovative research May 2021,Vol 8,Issue 5.
- [3]Pauzi.A.N, Muhammad N, Abdullah.N And Kamal.N. Current Authentication Methods Of Herbs And Herbal Products . Food Research (2022).
- [4]S.Sudha revathy, R.Rathinamala,M.Murugesan .Authentication Methods For Drugs Used In Ayurveda ,Siddha And Unani System Of Medicine. International journal of pharmaceutical science and research (2012).Vol.3,Issue 08.
- [5]Abdullahi R. Abubakar And Mainul Haque .Basic Extraction And Fractionation Procedures For Experimental Purposes . Journal Of Pharmacy And Bioallied Sciences.
- [6]K.Sahira Banu , Dr.I.Cathrine .General Techniques Involved In Phytochemical Analysis International journal of advanced research in chemical science April 2015 ,Vol 2, Issue 4 [7]Vaibhav Shinde , Kakasaheb R.Mahadik .Supercritical Fluid Extraction: A new Technology to Herbals .International Journal Of Herbal Medicine .January 2019.
- [8] Komal Patel ,Namrata Panchal ,Dr. Pradnya Ingle .Extraction methods International journal of advanced research in chemical science, Vol 6,Issue 3, 2019.
- [9]Andrew G.Mtewa ,Serawit Deyno, Felicien M.,Kasali ,Amanjot Annu, Duncan C. Sesaazi.International Jouranal Of Sciences : Basic And Applied Research International journal of sciences basic and applied research.
- [ 10] Md. Golam Rasul . Extraction ,Isolation And Characterization Of Natural Product From Medicinal Plants. December 2018.
- [11) Rushi Patel And Krushang Patel .Significance Of Various Chromatographic Techniques In Herbal Drug Analysis .Journal Of Chemical Of Pharmaceutical Research (ISSN:0975-7384) [12]Ankit Bansal .Chemometrics : A New Scenario In Herbal Drug Standardization.J.Pharm Anal.2014 Aug.
- [13]Gavali Pratiksha Suresh , Garute Komal Somnath, Sidhir Garje ,Ghazali Aarti Sanjay.Advance Herbal Technology. International journal of creative research thoughts. 1 January 2022.Vol.10,Issue 1 .