



INTERNATIONAL JOURNAL OF CREATIVE RESEARCH THOUGHTS (IJCRT)

An International Open Access, Peer-reviewed, Refereed Journal

MARINE DRUGS

Priyanka Mahajan^{2nd}, Mohammed Sufiyan^{1st}, Zahid Anwer^{3rd}

Abstract: This review give idea about elaborative aspects of marine drug, its classification, uses in different diseases, source. Also focused on marketed preparation of marine drugs, their scope in market and their output concern with patients, it included marine pharmacology in India & marine life and its related pollution.

Keywords- marine drugs, marine natural products, seaweed polyphenols, marine microalga, brown seaweed, marine organisms, microorganisms, drugs.

I. INTRODUCTION

DEFINATION OF MARINE DRUG

The study and identification of medically implanted or creatures in marine environments is known as marine pharmacognosy. It is a branch of terrestrial pharmacognosy, and the majority of medications are derived from sponges, algae, fungi, and marine bacterial and viral species.

HISTORY

Nearly three lakh known species of plants and animals from marine sources, representing 34–36 Phyla, are found in the oceans, which make up nearly 70% of the earth's surface. Some of these species are only originate in the marine ecosystem. The first living things are thought to have emerged in the ocean more than 3500 million years ago, and evolutionary development has given many marine organisms the necessary defences to endure in a hostile environment that includes high and low temperatures, changes in salinity and pressure, and the threat of mutation, bacterial and viral pathogens. One class of substance that can be extracted from marine organisms is called marine alkaloids. They can exhibition a variability of biological functions while having complicated and unique chemical structures. A naval surgeon, or less frequently a ship's doctor, oversees maintaining the crew's health while they are on board a warship. Since the start of time, humans have trusted on the seas for a variability of needs, including food, waste disposal, recreation, and economic possibilities. The World Register of Marine Species, Worms, estimates that there are around 240,000 marine species in existence (2021 census). Have complex and special chemical structures, but at the same time, they can show diversity in biological activities. A naval surgeon, or fewer frequently a ship's doctor, oversees maintaining the crew's health while they are on board a warship. Through human existence we have relied on the oceans – as a source of food, a place to dump trash, a destination for fun, a source of employment, etc.

The term "marine bio resources" refers to a variety of living things, including bacteria, fungi, other microorganisms, cyanobacteria, micro- and macro algae, sponges, Mollusca, other invertebrates, fish, fish co-products, plants, as well as chemicals derived from these kinds of living things. Despite some debate, it is generally accepted that estuaries, salt marshes, mangrove forests, and coral reefs are among the several types of maritime ecosystems. The open ocean, and the deep-sea ocean Marine topmost predators (counting sure species of predatory fish, seabirds, sea turtles, and marine mammals) have be situated future as ecosystem sentinels founded on their visible nature and capacity to indicate or respond to changes in ecosystem assembly and function that would otherwise be hard to detect ...

The drugs which are found from marine organisms are known as marine drugs. These marine drugs are used since olden times. Chines and Japanese are very well-known to use these resources. Interestingly, innumerable goods derivative from the marine organisms in some 'crude forms' have been usually used transversely the globe by the old-style physicians for thousands of years. Many of the species contain toxic compound the marine atmosphere is an annoying source of both biological and chemical variety. This variety has been the source of single chemical complex the marine with the potential. Industrial development has pharmaceuticals, cosmetics, nutritional increases molecular properties, fine chemical and chemicals. Marine toxins were informed to have a high potency about their pharmacological activities, and, thus, sometimes jointly denoted to as' toxins

SCOPE OF MARINE-The annual salaries at the U.S. Marine Corps range from \$27,358 on average to \$108,400. In comparison to the U.S. Marines, U.S. Navy SEALs are a more elite and self-confessed force. United States Marines don't like to be called soldiers. If you don't want to offend someone, call them Marines (usually capitalized). Soldiers are people who are members of the US Army and National Guard. Airmen are those who serve in the Air Force. Memberships of the Navy are sailors. Similar to the Army, the Marines categorise their enlisted personnel into "Military Occupation Specialties," or MOSs. The Marine Corps uses four-digit MOS designations to define and choose the range of positions and services made available by the USMC. When you sign, you will serve four years of demanding duty. After that, you can decide whether to re-join the Marine Corps or leave it. Although

the term "end of active deal" is used, you are still required to spend four years in the prepared inactive reserve. Small fish, crustaceans, and zooplankton are the ocean's main consumers. Fish, coral, penguins, whales, and other animals that consume zooplankton are the secondary consumers. The top killers in the ocean, sharks, killer whales, and leopard seals, eat both primary and secondary customers. Marine creation means a new or used watercraft, boat, marine motor, and a boat or watercraft promo. Since they often have to undergo far more rigorous basic training than those in the Army do, Marine Corps personnel—who are referred to as marines rather than soldiers—have a reputation for being among the toughest and best-trained combatants. The term also takes in an external motor or a boat with an inboard/external motor attached to it. The 2nd Battalion, 5th Marines based in Camp Pendleton boasts of its combat record that stretches back to the First World War. It is also the most ornamented battalion unit in the history of the Marine Corps. Previously known as the Marine Special Operations Regiment, the Marine Raider Regiment (MSOR). The Marine Raiders are a special operations unit of the Marine Corps Special Operations Command of the United States Marine Corps (MARSOC).

MARINE PHARMACOLOGY IN INDIA -

India has almost 8,000 kilometres of coastline with a variety of marine environments, including mangrove forests, dense, rocky intertidal coastlines, and coral. The potential of India's maritime environments is still largely untapped for its biotechnology and new medication development programmes. A handful of the carefully selected organisations are presently working to find life-saving pharmaceuticals from marine sources, including the Central Drug Research Institute in Lucknow, the Bose Institute in Kolkata, and the Central Institute of Fisheries Education in Mumbai. Numerous other Indian institutions, universities, and pharmaceutical companies have also acknowledged the significance of these subjects.

In the past, marine pharmacology received a lot of attention both in India and throughout the world. While taking into account the advantages of their abundance in nature and large-scale manufacturing, it is still necessary to examine the potential of the oceans as sources for the advancement of novel pharmaceuticals. The drug business is currently focused on finding novel molecules having previously undisclosed pharmacological features that can be used to generate new therapeutic agents for commercial application. This review has mostly concentrated on various marine medication types now in use and in various phases of studies for approval and future marketing. The examination has similarly tried to delve into the limitation and future leanings of the drug from marine sources.

Marine microorganisms in drug discovery: -

Marine microorganisms are predicted to be a valuable source of innovative, efficient medications due to their tremendous genetic and biochemical diversity. According to Parkes et al. (1994), marine bacteria make up 10% of the biosphere's living biomass carbon and represent a radically different environment than their global counterparts. Although they also exist in open oceans and are linked to marine life, these bacteria are primarily found in deposits. It was unexpected to learn that many of the bioactive substances found in marine invertebrates are really created by the microorganisms that live inside of them. Production of such expensive antibiotics and other important drugs is pushed by competition between bacteria for nutrients and space in the marine atmosphere. It is encouraging to learn that marine invertebrate-associated microbes make good candidates for a medication discovery effort (Jensen & Fenical, 2000; Henschel et al, 2003; Imada, 2004; Thakur et al, 2005). In addition to providing more than 70% of naturally occurring antibiotics, actinomycetes constitute a significant bacterial phylum. The quest for antibiotics from this source is ongoing because the oceans are a massive repository of new actinomycete species. The status of various potential medications derived from marine microorganisms was recently examined by Professors Jensen and Fenical of the Scripps Institute of Oceanography in the United States (Jensen & Fenical, 2000).

MARINE LIFE-

BIRDS.

FISHES.

REPTILES.

SEA LIONS.

SEALS.

SHARKS & RAYS.

SQUID & OCTOPUSES.

WHALES & DOLPHINS.

TYPES OF POLLUTION-

Marine debris pollution.

Plastic pollution.

Ocean acidification.

Nutrient pollution.

Toxicants.

Underwater noise.

Other.

Marine medicine –

The field of marine medicine focuses on the prevention and treatment of morbidity among seafarers, the treatment of disorders brought on by exposure to high ambient pressure settings, and the therapeutic use of these environments.

Source of marine drug-

It has been demonstrated that several marine species are powerful medication suppliers. Sponge, soft coral, sea fans, sea hares, nudibranchs, bryozoans, and tunicates make up the majority of these invertebrates.

Marine resources –

Marine sediments come in four different types: lithogenous, biogenous, hydrogenous, and cosmogenous. The three categories of marine resources are typically: biotic resources, abiotic (mineral and energy) resources, and commercial resources (navigation, aviation, trade and transport etc.). Typically, live and non-living resources are used to divide up marine resources.

10 Marine producers-

1. Phytoplankton
2. Seaweed
3. Algae
4. Rhodophyta
5. Brown algae
6. Sea lettuce
7. Cladophora
8. Diatoms
9. Euglenoids
10. Dinoflagellates

Table.1: Selected example of marine natural products, which are currently in market or in clinical phases.

PRODUCT	SOURCE	APPLICATION AREA	STATUS
ARA-A	Marine sponge	Antiviral	Market
ARA-C	Marine sponge	Anticancer	Market
CEPHALOSPORINS	Marine fungi	Antibiotic	Market
CONOTOXINS	Cone snail	Chronic pain	Phase 1/2/3
GTS21	Nemertine worm	Alzheimer disease	Phase 1/2
LAF389	Sponge	Cancer	Phase 1
BRYOSTATIN-1	Bryozoan	Cancer	Phase 2
YONDELIS™	Sea squirt	Cancer	Phase 2/3
DOLASTATIN-10	Sea slug	Cancer	Phase 2
ILX651	Sea slug	Cancer	Phase 1
CEMADOTIN	Sea slug	Cancer	Phase 1
DISCODERMOLIDE	Sponge	Cancer	Phase 2
HTI286	Sponge	Cancer	Phase 1
APLIDIN™	Sea squirt	Cancer	Phase 1
SQUALAMINE LACTATE	Shark	Cancer	Phase 2
IPL512602 (steroid)	Sponge	Inflammation, asthma	Phase 2

MARINE NATURAL PRODUCTS –

Numerous natural chemicals produced by these organisms have chemical warfare properties and are powerful physiological process inhibitors. Many exhibit pharmacological properties and are beneficial in the treatment of cancer, AIDS, and arthritis. Many different compounds exhibit distinctive structural characteristics and different biological activity. Marine drugs are extremely strong bioactive molecules in recent years an important number of novel metabolites with strong pharmacological properties have been exposed from the marine organism although there are only a few marine drives from marine natural products are now in the clinical pipeline with more clinical development. [2]

CLASSIFICATION OF DRUG MOLECULES OF MARINE ORGANISMS-

The enormous quantum of fresher and effective drug molecule derived from the wide spectrum of marine organism across the world may be carefully and logically classified based on their specific pharmacologic activities as stated below-

- (A) Anti-neoplastic Agents-
- (B) Cardiovascular active drugs-
- (C) Marine toxins-
- (D) Microbial drugs-
- (E) Anti-biotic substances-
- (F) Anti-inflammatory and antispasmodic agents-
- (G) Miscellaneous pharmacologically active substance-

(A)Anti-neoplastic Agents-

Antineoplastic drugs are medicines used to treat cancer. Other names for antineoplastic drugs are anticancer, chemotherapy, chemo, cytotoxic, or hazardous drugs. These drugs originate in many forms, including liquids or pills.

Crassin acetate-

It is the member of cembranoids which are cyclic diterpenes.

Biological source: It is obtained from the CARIBBEAN GORGONIAN pseudoplexaura porosa.

USES: crassin acetate was experimental to be moderately inert to the mammalian system but on the contrary found to be extremely cytotoxic to human leukemic cells in vitro and to the mouse fibroblasts.

SINULARIN-

Biological source: sinularia and its dihydro congener are obtained from sinularia flexibilis.

Uses: It possess anticancer actions

SINULARIN FLUDARABINE SYNONYM: 2-fluorovidarabine, 2F-AraA.

CHARACTERISTIC FEATURES:

1. It is found as crystals from ethanol and water having MP 260 c
2. It shows specific optical rotation
3. It is sparingly soluble in water and organic solvents

Uses: it is used as an antineoplastic agent.

(B)Cardiovascular active drugs-

Cardiovascular drugs are the common name of compounds used to treat different heart disorders (such as congestive heart failure, angina, or arrhythmia) or diseases of the vascular system (e.g., hypertension).

The cardiovascular active drugs may be broadly classified under the following two categories, namely:

- (a) Cardio tonics
- (b) Hypotensive compounds

LAMININ:

Biological source: Laminin is obtained from a marine algae laminaria Angus tata

CHEMICAL STRUCTURE CHARACTERISTIC FEATURES:

- It is the abundant structural component of the basal lamina
- It is critical to the stability of the extracellular medium and to the adhesion of cells to the basement membrane
- It belongs to the family of HETEROTRIMERIC GLYCOPROTEINS composed of a heavy chain, which are linked by disulphide bonds to form an asymmetrical cross- shaped structure.

USES:

- It shows hypotensive effect.
- It also exhibits diverse biological actions.

ELDOISIN:

It is a controlling hypotensive compound. It also shows strong vasodilator effects

Biological source: Eldoisin is obtained from the posterior salivary glands of *Eledone* spp. [small octopus] *Eledone moschata*

Chemical structure of eldoisin

CHARACTERISTIC FEATURES:

- Eldoisin is obtained as a sesquihydrate powder that gets decomposed at 230 °C
- It has specific optical rotation
- It is originating to lose its activity progressively when incubated in blood.

USES:

1. It is found to stimulate extra vascular smooth muscle.
2. Eldoisin acts as a potent vasodilator and hypotensive agent.
3. It similarly stimulates lacrimal secretion.
5. Its reasons salivation and improves capillary permeability in certain specific species.

SEPONGOSIN:

It is chemically nucleoside (methoxy derivative of adenosine) derived it reduces equally the rate and the force of contraction of heart.

Biological source: It is found from the Caribbean sponge *Cryptothoa crypta* and with a minor structural adjustment of the parent isolated nucleoside recognized as arabinosylnucleoside.

USES:

1. It exhibited various coronary effects resembling to those of adenosine, for instance coronary vasodilation and negative inotropy.
2. It is originating to exert more marked and pronounced long-acting effects.
3. It acts as a hypotensive at such a dose level at which adenosine is observed to be absolutely inactive.
4. It reduces the rate as well as the force of contraction of heart.

(C)MARINE TOXINS-

Marine toxins are chemicals and bacteria that can contaminate certain types of seafood. Eating the seafood may result in foodborne illness. The seafood may look, smell, and taste normal.

TETRODOTOXIN:

It is normally abbreviated as TTX, it is a potent neurotoxin

Biological source: Tetrodotoxin is found from the ovaries and liver of many tetrodontidae; particularly the spheroids *Rubripes* (globe fish) it is also obtained from the puffer fish (tetrodon species) *Spherooides rubripes* (GLOBE FISH)

USES: Tetrodotoxin gets bound mainly to the Na⁺ channels on the external of excitable membrane, so inducing Na⁺ influx in K⁺ influx within a few milliseconds of the accompanying membrane depolarization

BREVETOXIN:

Biological source: a plethora of polycyclic polyether metabolites have been obtained from the Dinoflagellate *Ptychodiscus brevis*; and now the Brevetoxins are commonly known as from the generic nomenclature that is p. brevis toxins.

USES:

- It exerts an excitatory effect on the isolated neuromuscular and other cells.
- It causes both neurological and gastrointestinal disorder

CIGUATERA TOXINS:

Biological source: Ciguatoxin (CTX) is found in *Gymnothorax javanicus* (Moray Eel), besides in a variety of coral reef fish, for instances: *Lutjanus bohar* (Red snapper).

USES:

- It causes neurological problems
- It causes cardiac and gastrointestinal problems.
- CTX- is found to apply its actions at the ends specifically.
- interestingly CTX acts as a cardio tonic at the nerve ends specifically.
- whereas at higher dose levels there is an apparent depression in both heart rate and in respiration.

(D)ANTIMICROBIAL DRUGS-

Antimicrobials – with antibiotics, antivirals, antifungals and ant parasitic – are medications used to prevent and treat infections in humans, animals and plants.

Zonanol:

Biological source: Zonanol and Iso-Zonanol are both found from *dictyopteris zonaroides* (brown algae).

USES: Zonanol is used as anti-inflammatory.

(E)ANTIBIOTICS-

Antibiotics are chemical substances formed by an existing organism that kill or stop the growth of disease-causing micro-organisms such as fungi and bacteria. Examples of antibiotics

A few antibiotics from the various marine organisms, namely:

- okadaic acid,
- acanthifolicin
- norhalichondrin -a

OKADAIC ACID-

Synonym: Halochondrine A (marine black sponge)

Biological source: it is found from *Halichondria* (Okadai)

CHEMICAL STRUCTURE CHARACTERISTIC FEATURES:

1. It is obtained from dichloromethane
2. It has specific optical rotation 3. It also reported as in crystal from

USES:

1. It is important biochemical tool as tumour promoter and probe of cellular regulation
2. It is found to be far more cytotoxic to KB- cells
3. It can transport divalent cat ions e.g.: Ca⁺

ACANTHIFOLICIN-

Biological source: Acanthifolicin is found from *pandaros acanthifolium* (sponge)

CHEMICAL STRUCTURE CHARACTERISTIC FEATURES:

1. It possesses an antibacterial activity
 2. It also exerts cytotoxic actions
 3. It is originating to be lethal to mice at low dose level
1. It is probe of cellular regulation
 2. It is more cytotoxic.

NOR HALICHONDRIIN-A-

Biological source: norhalichondrin & some other halichondrin structural analogues have been found from halichondria okadaei (sponge).

CHARACTERISTIC FEATURES:

- It is a polyether macrolide.
- The structure action correlation studies about their derivative; and, their structural remains are of significant biological interest

USES: It is creating to use antitumor activity.

(F) ANTI-INFLAMMATORY and ANTI-SPASMODIC AGENT-

Anti-inflammatory: is the property of a substance or treatment that reduces inflammation or swelling. About half of analgesics are anti-inflammatory medications, also referred to as anti-inflammatories.

Antispasmodic: A drug that calms, stops, or lessens the frequency of muscle spasms, particularly in smooth muscles like those in the gut wall.

TETRADO TOXIN-

Biological source: Tetrodotoxin is obtained from liver and ovaries of puffer fish

USES:

1. It is used as anti- inflammatory
2. It has analgesic effect
3. It acts as muscle relaxant

(G)MISCELLANEOUS PHARMACOLOGICALLY ACTIVE SUBSTANCE-

Chemicals and chemical products that are employed in industrial, domestic, or research settings. The specific drug preparations, as well as the ingredients used in the production and stabilisation of pharmaceutical preparations and agricultural agents, are all included in this list.

LATRUNCULINS-

Biological source: latrunculin are gained from latrunculin magnifica keller (red sea sponge) they are also found in chromodoris elisabethina (pacific nudibraanch) and the spongia mycofijiensis (fijian)

USES:

1. They are exclusively in founding of molecular mechanism of motile methods
2. Unlike cytochalasins the LAT-A and LAT- B do not afford any change in the polymerization rate of active filaments.

DOMOIC ACID-

Biological source: It is derived from the red algae chondria armata okamura (rhodomelaceae), commonly known as DOMOI in Japanese, hence the name domoic acid.

CHEMICAL STRUCTURE: Domic acid is a neurotoxin that disrupts neurochemical functions, causing temporary memory loss, brain damage, and, in severe cases, human death. In marine mammals, domic acid frequently causes convulsions and tremors.

Producing drugs from marine sponges-



Fig.: Sponges



Fig.: Sponge cell surrounded by bacterial colony

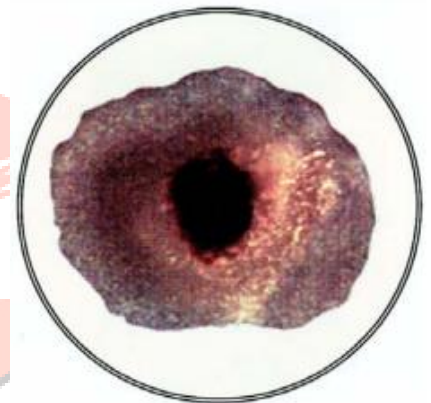

Fig.: Sponge suberites domuncula

Marine sponges may contain a variety of uncommon metabolites, such as cytotoxic and anticancer compounds. Natural populations of sponges are either insufficient or unreachable for the generation of industrial amounts of concentration metabolites. New sponges can be grown from cuttings from a parent sponge in the water or under more controlled settings in aquariums. The principles of sponge cells and different types of cell aggregation offer a new method of creating sponge metabolites. From a team of scientists in Spain and New Zealand, a review on producing sponge biomass to get past supply limitations for using marine sponges to make pharmaceuticals is now available. The analysis of production methods includes sponge cell and prim morph culture, controlled-environment aquariums, marine aquaculture, and more. Currently, the only practical and inexpensive ways to produce sizable amounts of sponge biomass are through marine and aquarium cultivation. Future metabolite production from cultivated sponge cells and prim morphs may be viable, even though large-scale biomass production from cell and prim morph cultures is not yet practical. The investigation of production methods includes discussions of sponge cell and prim morph culture, marine aquaculture, controlled aquarium conditions, and other topics.

CLASSIFICATION OF MARINE PHARMACOLOGY–

Marine pharmacology can be classified based on source of the applicant drug.

1. Genetically engineered marine organisms
2. Manufacture of pharmaceuticals and nutraceuticals of marine origin
3. Chemicals produced by or found in marine organisms shown to have a wide variety of applications as pharmaceuticals.

Some of the drugs of marine origin approved for human use in different parts of the world are as follows:

Cytarabine (cytosine arabinoside or arabinosyl cytosine, ara-C)-



Cytarabine, aka 1- β -D-Arabinofuranosylcytosine, Ara-C, CYTOSAR-U® (Pfizer, New York City, NY, USA), and DEPOCYT® (Pacira Pharma, San Diego, CA, USA; Bedford Lab, Seattle, DC, USA, Enzon Pharmaceuticals, Piscataway, NJ, USA), (Figure 1C) is the synthetic analog of naturally occurring spongothymidine

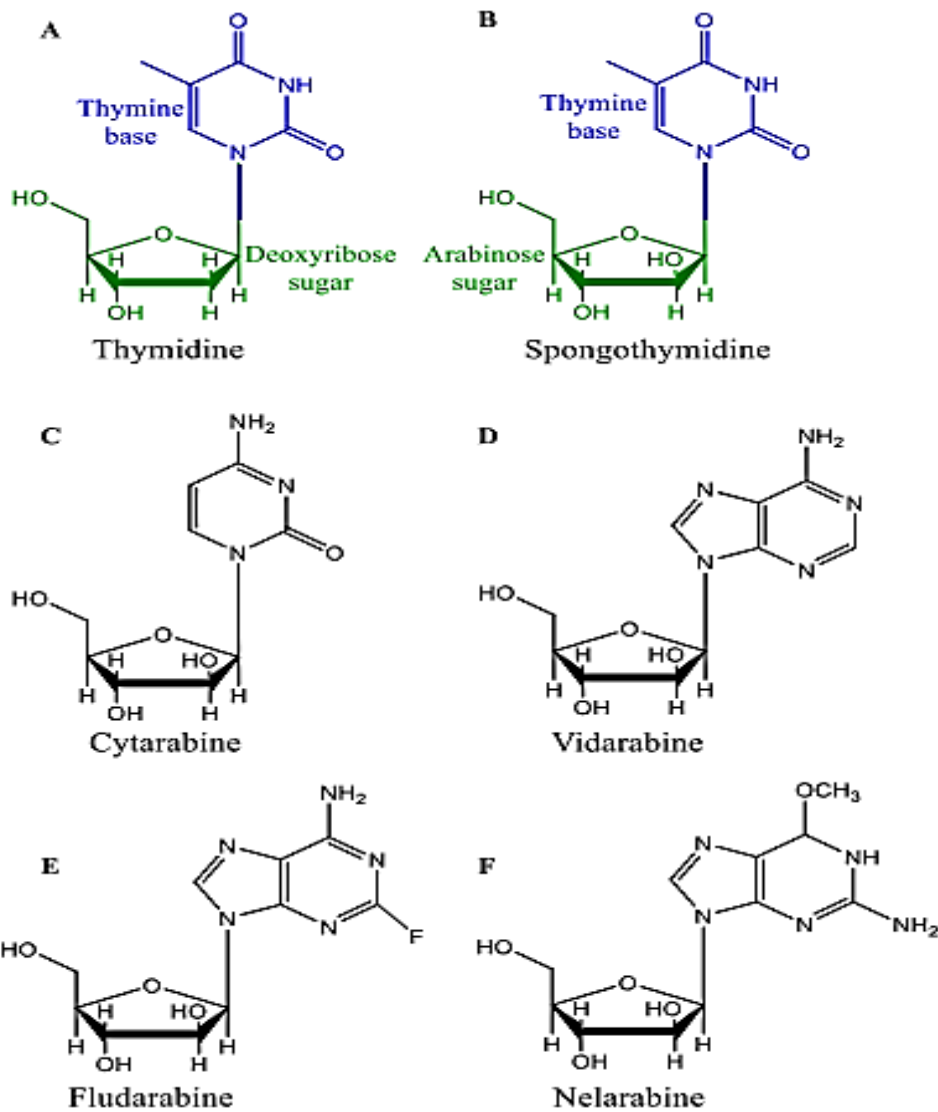

Figure. The structure of thymidine & other arabinosides

Even today, more than 50 years after its initial approval in 1969, cytarabine one of the most powerful anticancer agents—is used to treat acute leukaemia . Cytarabine, a prodrug, is phosphorylated intracellularly to produce the active substance ara-cytidine-50-triphosphate (ara-CTP). The intracellular conversion of ara-C to ara-CTP raises the concentration of ara-bioactive CTP before rapidly acting as a potent inhibitor of mammalian DNA synthesis (Figure 2). The intermediates that result in the harmful effect are the integration of ara-CTP into the developing DNA, which causes a faulty DNA strand, as well as DNA polymerase inhibition, which is essential for megaloblastosis. In the S phase of the cell cycle, the faulty DNA matures into abnormal chromosomes with numerous chromatid breaks and disintegrates, which causes cell death.

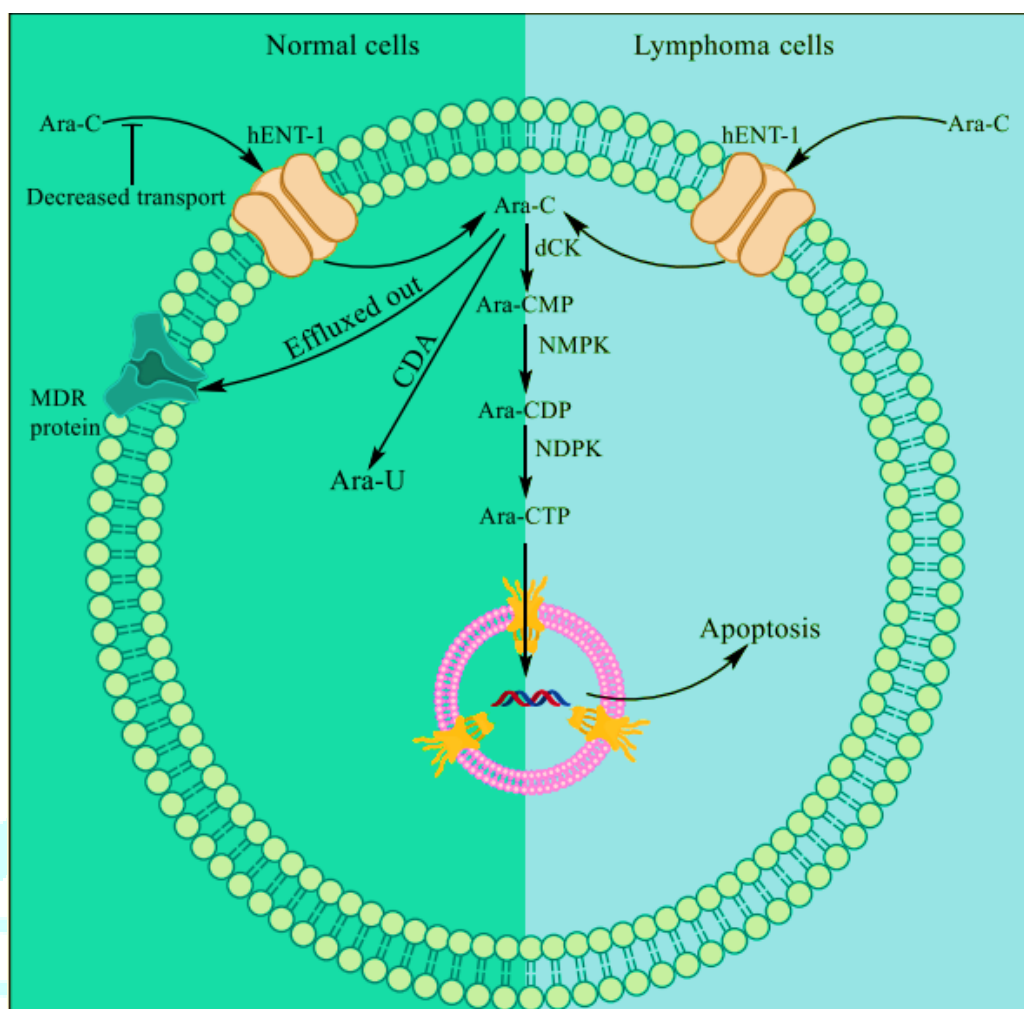

Figure 2. Mechanism of lymphoma cytotoxicity and ara-C resistance in healthy cells. Compared to normal cells, lymphoma cells export less ara-C and import more of it. A series of phosphorylation processes are catalysed by deoxycytidine kinase (dCK), nucleoside monophosphate kinase (NMPK), and nucleoside diphosphate kinase (NDPK), which convert ara-C into bioactive ara-C and bioactive ara-CTP.

The cytidine deaminase (CDA) enzyme, which is present in the liver and intestine, converts Ara-C, when administered orally, to the inactive form uracil arabinoside. When ara-C is administered intravenously, active drug concentrations in plasma and cerebral fluid are much higher since uracil arabinoside accounts for around 80% of the medication's excretion in urine. DepoCyt® (Pacira Pharmaceuticals, San Diego, USA), a liposomal formulation of cytarabine for sustained delivery of the drug, was licenced by the US Food and Drug Administration (FDA) in 1999 for the treatment of lymphomatous meningitis. Because of delayed, prolonged delivery and the potential for nanosized liposomes to evade the drug efflux pump as they enter the cells intact, the liposomal preparation of cytarabine alone or in combination with anthracyclines like daunorubicin is more effective. Patients taking cytarabine medication frequently experience anorexia, nausea, vomiting, diarrhoea, haemorrhage, and myelosuppression as side effects. Cytarabine risks for central nervous system (CNS) toxicity and renal and hepatic failure have been documented following prolonged intravenous or intrathecal dosing. An intriguing question about the specificity of cytarabine toward leukemia with respect to other carcinomas has also been investigated since its discovery.

Cytarabine is an artificial pyrimidine nucleoside derivative from spongothymidine and primarily isolated from a Caribbean sponge species *Tethya crypta*. It is FDA approved and mostly used in different types of leukaemia, including acute myelocytic leukaemia, lymphocytic leukaemia, meningeal leukaemia, and blast crisis phase of chronic myelogenous leukaemia.

Vidarabine (adenine arabinoside, ara-A or arabinofuranosyladenine)-



The Caribbean Sponge *T. crypta* was used to create the synthetic purine nucleoside known as vidarabine, which is currently derived from the bacteria *Streptomyces antibioticus*. It is approved by the FDA for treatment in superficial keratitis, acute keratoconjunctivitis, and recurrent epithelial keratitis caused by HSV types 1 and 2.

Vidarabine, also known as 9-D-Arabinofuranosyladenine, Ara-A, and VIRA-A® (King Pharmaceuticals, Bristol, TN, USA), is a man-made version of arabinonucleosides that was influenced by spongothymidine and spongouridine, which are found in nature. Vidarabine displays little to no suppression of RNA viruses but selective inhibition of DNA viruses. Vidarabine was primarily created as a potential anticancer drug but was formally approved by the US FDA in 1976 as an ophthalmic ointment (3%) with indications for the treatment of keratoconjunctivitis, recurrent epithelial keratitis brought on by HSV1/2, and superficial keratosis resistant to idoxuridine. However, the medicine was taken off the market since a superior commercial substitute was available. Due to the drug's relatively low solubility and high body clearance, the therapeutically active concentration was not reached. Additionally, the drug is quickly delaminated by adenosine deaminase to its sedentary form arabinosyl hypoxanthine, which limits its clinical use to specific pathological conditions. However, little progress was made when the medication was used in combination with the adenosine deaminase inhibitor deoxycoformycin (dCF, pentostatin). The more potent alternative fludarabine (described in the section after this) quickly gained popularity.

Ziconotide-

However, the medicine was taken off the market since a superior commercial substitute was available. Due to the drug's relatively low solubility and high body clearance, the therapeutically active concentration was not reached. Additionally, the drug is quickly deaminated by adenosine deaminase to its sedentary form arabinosyl hypoxanthine, which limits its clinical use to specific pathological conditions. However, little progress was made when the medication was used in combination with the adenosine deaminase inhibitor deoxycoformycin (dCF, pentostatin). The more potent alternative fludarabine (described in the section after this) quickly gained popularity.



Brand Names Prialt Generic Name Ziconotide

Drug Bank Accession Number DB06283

Indication Ziconotide is intended to manage severe chronic pain in patients who have failed to respond to prior treatments and for whom intrathecal therapy is necessary. 18Associated Conditions Severe, Chronic Pain

Pharmacodynamics

Ziconotide blocks N-type calcium channels that are important for nociceptive signalling, mainly in the dorsal horn of the spinal cord^{5, 7, 8, 9,12,14,18}. Although binding can alter, Ziconotide has been identified as having a small therapeutic window^{13, 18}, necessitating cautious dosing to assure therapeutic properties while limiting side effects. Patients on Ziconotide may develop neuropsychiatric and cognitive problems, decreased levels of consciousness, and increased serum creatine kinase levels. Additionally, ziconotide may raise your risk of contracting an infection, particularly severe meningitis instances. It is recommended that patients take off the dose if they are stopping opiates for ziconotide instigation¹⁸. Acute and persistent inflammatory pain can be managed with a wide variety of drugs, but chronic neuropathic pain is more difficult to manage. Over-the-counter pharmaceuticals like acetaminophen can frequently effectively treat mild to moderate acute pain, but stronger analgesics like opioids are needed for severe acute pain.

Ziconotide, also referred to as SNX-111, is a brand-new non-opioid analgesic medication. It is a synthetic version of the peptide - conotoxin MVIIA (-MVIIA), which is present in the venom of the sea snail *Conus magus*, which eats fish. Ziconotide must be delivered intrathecally to patients in order to achieve maximal analgesic efficacy with a lower risk of major side effects because it has a limited ability to pass the blood-brain barrier. With this spinal route of administration, ziconotide can quickly reach its high local concentration, which accelerates the onset of analgesia. A novel non-opioid analgesic medication is ziconotide, also referred

to as SNX-111. It is a synthetic version of a peptide called ω -conotoxin MVIIA (ω -MVIIA), which is present in the venom of the sea snail *Conus magus*, which eats fish. Ziconotide must be delivered intrathecally to patients in order to achieve maximal analgesic efficacy and minimise the risk of major adverse effects due to its insufficient capacity to pass the blood-brain barrier. This spinal route of administration enables ziconotide to achieve its high local concentration in a little amount of time, which accelerates the onset of analgesia. An alternative is to utilise a temporary external micro infusion device. To obtain the ideal mix of analgesic efficacy and side effects, the dose of ziconotide can be titrated progressively using a fermentation pump in accordance with the needs and comfort of the patient.

Ziconotide is a powerful analgesic with a unique mechanism of action that involves the potent and targeted blockade of N-type calcium channels, which regulate neurotransmission at several synapses. The capacity of ziconotide to block spinal cord-level pain signalling is probably what gives it its analgesic effectiveness. Ziconotide, a peptide medication, has only been licenced for treating patients' severe chronic pain when given intrathecally. Significantly, chronic use of ziconotide does not lead to the development of tolerance or addiction. The current review examines the various pre-clinical research that demonstrated ziconotide's antinociceptive mechanism of action in animals, as well as the innumerable studies that addressed the *in vitro* biochemical and electrophysiological effects of ziconotide. This review also takes into account the pivotal Phase 3 (and other) clinical trials that were conducted to support ziconotide's approval for the treatment of severe chronic pain. It also makes an effort to provide some insight into the potential discovery and development of newer analgesic medications that would act in a manner similar to ziconotide but might provide improved safety, tolerability, and usability in the future.

Ziconotide: Structural considerations and *in vitro* biochemical and electrophysiological studies:

The ω -conotoxins, such as ω -GVIA, ω -MVIIA, ω -MVIIC, and ω -CVID, constitute a structurally related group of polypeptide molecules that are found naturally in the venom of certain species of marine snail. In general, the ω -conotoxins bind to voltage-gated calcium channels with high affinity and effectively block calcium flux. Individual peptides show distinctive specificities for diverse channels despite structural conservation among the various ω -conotoxins and among their binding sites on voltage-activated calcium channels.

Summary: Ziconotide, an N-type calcium channel antagonist, is used to treat people with severe chronic pain who are unable to take alternative medications such intrathecal morphine and systemic analgesics or who have not responded to them well.

Trabectedin-

A marine natural product that is taken from the tunicate species *Ecteinascidia turbinata*, which is often found in the Mediterranean and Caribbean Seas. The tetrahydroisoquinoline class alkaloid trabectedin was the first marine-derived anticancer particle to receive EU authorisation for use in the treatment of soft-tissue sarcoma and relapsed instances of platinum-sensitive ovarian cancer.



Eribulin mesylate (E7389) or halichondrin B-

It is a polyether macrolide natural particle initially extracted from marine sponges, with potent anticancer activity described in preclinical animal models. Eribulin is a potent particle On-going Phase III studies are estimating the comparative clinical efficacy of eribulin versus capecitabine and eribulin versus other preferred treatment choice. Which produces irretrievable antimetabolic activity leading to cell death by apoptotic pathway.



Soblidotin (auristatin PE or TZT-1027)-

Is dolastatin 10 the source of a synthesised dolastatin backbone? In addition to its inhibitory effect on tubulin, it is a vascular disruptive drug that causes the internal vasculature of the tumour to collapse. This medication is undergoing clinical Phases I, II, and III trials with several firms in an effort to deploy it as a weapon against particular monoclonal antibodies connected via unique peptides.

Tetrodotoxin-

A very well recognized “marine toxin,” and highly relieved guanidine-derivative. It is not an anti-tumour agent, currently in Phase III trials as analgesic against incompetently controlled pain related to the cancer. A Phase II trial is constant to assess the effectiveness of tetrodotoxin against the neuropathic pain related to chemotherapy-induced peripheral neuropathy.

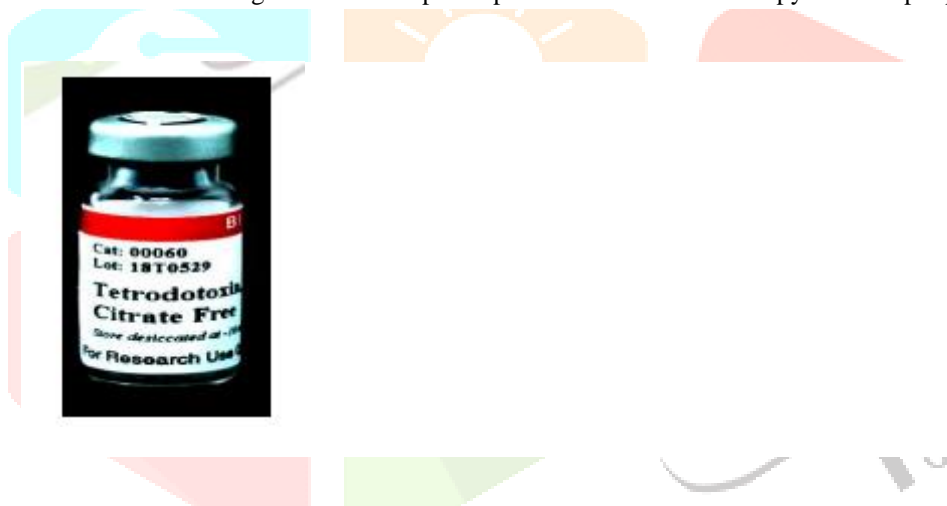

DMXBA (GTS-21) [3-(2,4-dimethoxybenzylidene)-anabaseine; GTS-21]-

It is a synthetic copy of anabaseine, an alkaloid that is present in a variety of aquatic worm species belonging to the phylum Nemertea. According to reports, DMXBA helps the central nervous system, enhances cognition, and treats sensory gating deficiencies in a range of lab animals. Cognitive functions have significantly improved in schizophrenia individuals participating in a Phase II clinical trial of the particle.

Plitidepsin

It is a natural marine depsipeptide that is currently discovered through complete synthesis. The main source of its isolation was an *Aplidium albicans* tunicate discovered in the Mediterranean Sea. Plitidepsin has an exceptionally low nanomolar (nM) range of IC₅₀ values and is a highly effective apoptosis inducer. The most significant side effects associated with most plitidepsin schedules included muscle toxicity, an increase in transaminases, overall weariness, diarrhoea, and cutaneous rash.

Elisidepsin (PM0273)

It belongs to the Kahalalide family of chemicals and is a brand-new cyclic peptide derivative derived from marine sources. Phase II progress is now being made, and there is preliminary indication of anticancer potency and an encouraging therapeutic index. It has demonstrated strong in vitro cytotoxic activity against a variety of human tumour cell lines, which may be due to the production of oncolytic cell death as opposed to apoptotic cell death.

PM00104 (Zalypsis)

It is a brand-new alkaloid with the ability to bind DNA. It is related to jorumycin, which is recovered from the skin and mucus of the Pacific nudibranch (*Jorunna funebris*), as well as to renieramiycins, which are extracted from several sponge and tunicate species. Previous preclinical in vivo research using these compounds revealed considerably strong antitumor activity in cells from breast, prostate, and kidney cancers with only a mild antitumor effect on colon cancer cells. The primary toxicities associated with Zalypsis therapy during the Phase I trials were reversible haematological abnormalities or an imbalance in liver enzymes.

Uses:**Antibacterial****Immunomodulatory****Anti-fungal****Anti-inflammatory****Anticancer****Antimicrobial****Neuroprotective****Analgesic****Antimalarial properties****Marine Bioactive Compounds Available on the Market-**

The most appropriate way to continue the topic-by-topic discussion of marine pharmaceuticals is to offer a short-term indication of the marine drugs mentioned in this study in Table 1. Table 1 also provides information on the variety of marine medications now used in clinical settings. These medications are divided into six groups based on a non-uniform classification methodology that keeps the context flowing throughout each category. The majority of medications are grouped according to how complicated their structures are to make, such as "spongonucleosides," "antibody-drug conjugates," and "peptides or proteins employed as drugs or used in drug preparations," although some are also categorised according to how they work, such as "microtubule inhibitors" and "deoxyribonucleic acid (DNA) alkylating agents", or their natural source of abundance, such as "fish oil and its components as drugs". Table 1 briefly summarizes significant and relevant info along with the suggestions for clinical use and the mechanisms of action of drugs.

Name (drug bank ID)	Brand name (company)	Source organisms	Type (MW)	Mechanism of action	Treatment indications, approving agency (year)
		Spongonucleosides			
CYTARABINE,AR A-C (DB00987)	CYTOSAR-U® (Pfizer, New York City NY,USA) and DEPOCYT® (Pacira pharma, san diego,CA,USA, Bedford Lab, Seattle,WA,USA, Enzon Pharmaceuticals, piscataway,NJ,USA)	Cryptotethia crypta (sponge)	Small molecule (243.22Da)	Synthetic spongonucleosides analog, arrests cells in S phase by inhibiting DNA synthesis	Remission induction in acute nonlymphocytic leukemia, FDA (1969)[5] Lymphomatous meningitis, FDA, (1999)[6]
VIDARABINE,AR A-A (DB00194)	VIRA-A® (King Pharmaceuticals, bristol,FL,USA)	Cryptotethia crypta (sponge)	Small molecule (267.24Da)	Synthetic spongonucleosides analog, stops the replication	Acute keratoconjunctivitis and recurrent superficial keratitis caused by HSV-1 and HSV-2, FDA, (1976)[7]

				of herpes viral DNA	
FLUDARABINE, F-ARA-A (DB01073)	FLUDARA® (Sandoz, Basel, Switzerland) and OFORTA® (Sanofi-Aventis, Paris, France)	Cryptotethia crypta (sponge)	Small molecule (285.23Da)	Synthetic spongoucleosides analog, inhibits DNA synthesis by inhibiting DNA polymerase alpha, ribonucleotide reductase, and DNA primase	B-cell CLL, FDA (1991)[8]
NELARABINE (DB01280)	ARRANON® (GSK, Brentford, UK) ATRIANCE® (Novartis, Basel, Switzerland)	Cryptotethia crypta (sponge)	Small molecule (297.27Da)	Synthetic spongoucleosides analog, is metabolised into ara-GTP, competes with Dgtp, and is incorporated into the DNA, inhibiting DNA elongation	T-cell acute lymphoblastic leukemia and T cell lymphoblastic lymphoma, FDA (2005)
HISTOCHROME	Pacific-ocean institute of Bioorganic Chemistry, Vladivostok	Scaphechinus mirabilis (sea urchin)	Small molecule (220 Da)	The drugs prevents DNAdam age and regulates apoptosis under oxidative stress condition	Used to treat degenerative diseases of the retina and cornea, macular degeneration, etc. myocardial ischemia/reperfusion injury etc. Russia (1999)[10]
		MICROTUBULE INHIBITORS			
ERIBULIN MESYLATE (DB08871)	HALAVEN® (Eisai Bunkyo, japan)	Halichondria okadai (sponge)	Small molecule ,orphan (826.00 Da)	Polyether macrolide, arrests cells in G2/M phase by	Metastatic breast cancer, FDA(2010)[11] unresectable or metastatic liposarcoma, FDA(2016)[12]

				inhibiting microtubule growth after direct interaction	
			DNA ALKYLATING AGENT		
TRABECTEDIN, ET-743(DB05109)	YONDELLS® (PharmaMarSA, Madrid,Spain)	Ecteinascidia turbinata (tunicate)	Small molecule ,orphan (761.80 Da)	DNA alkylating agent, forms adducts with DNA guanine residue ion the minor groove, bends the DNA helix towards the major groove, and disrupts the association of DNA binding proteins	Soft-tissue sarcoma and relapsed platinum-sensitive ovarian cancer, EMA(2007)[13] unresectable or metastatic liposarcoma or leiomyosarcoma, FDA(2015)[14]
LUBINECTEDIN (DB12674)	ZEPZELCA™ (PharmaMar SA, Madrid,spain)	Ecteinascidia turbinata (tunicate)	Small molecule ,orphan (761.80 Da)	DNA alkylating agent, forms adducts with DNA guanine residue ion the minor groove, bends the DNA helix towards the major groove, and disrupts the association of DNA binding proteins	Metastatic SCLC,FDA (2020)[15]

		ANTIBODY-DRUG CONJUGATES			
BRENTUXIMAB VEDOTIN (DB08870)	ADCERTIS® (Seattle genetics, bothell, wahington ,WA,USA)	Dolabella auricularia (mollusk)	Biotech (-153 kDa)	The antibody component (IgG1)target CD30 and MMAE disrupts the microtubules after internalization	Hodgkin lymphoma and systemic anaplastic large-cell lymphoma, FDA(2011)[116]
POLATUZUMAB VEDOTIN (DB12240)	POLIVY™(Genentech,san,francisco,CA,USA)	Dolabella auricularia (mollusk)	Biotech (-150 kDa)	The antibody component (IgG1)target CD79b and MMAE disrupts the microtubules after internalization	Relapsed or refractor diffuse large B-cell lymphoma,FDA(2019)[17]
ENFORTUMAB VEDOTIN (DB13007)	Padcev® (Astellas Pharma US inc.Northbrook,II, USA)	Dolabella auricularia (mollusk)	Biotech (-153 kDa)	The antibody component (IgG1)target nectin-4 and MMAE disrupts the microtubules after internalization	Treatment of patients with advanced, treatment-resistant urothelial cancer, FDA(2019)[18]
BELANTAMAB MAFODOTIN (DB15719)	Blenrep® (GlaxoSmithKline, Brentford UK)	Dolabella auricularia (mollusk)	Biotech (-153 kDa)	The antibody component (IgG1)target BCMA (B-cell maturation antigen)and MMAF	Treatment of adult patients with relapsed or refractor multiple myeloma who have received at least 4 prior therapies, including antibody, and an immunomodulatory agent, FDA (2020)[19]

				disrupts the microtubules after internalization	
		PEPTIDES OR PROTEINS USED AS DRUGS OR IN DRUG PREPARATION			
PILIDEPSIN(DB04977)	APLIDIN® (PharmaMar SA, Madrid, Spain)	Aplidium albicans (sea squirt)	Small molecule, orphan(1110.30 Da)	Blinds to the gene product of Eef1A2, thus inhibiting cancer cell viability	Tumours in pancreatic, stomach, bladder and prostate cancers, TGA(2018)[20]
ZICONOTIDE (DB06283)	PRIALT® (Azur Pharma, Dublin, Ireland)	Conus magus (marine snail)	Small molecule (26.39.20 Da)	Blocks excitatory neurotransmitter release by inhibiting the N-type calcium channels of primary nociception afferent nerves and relieves pain	Severe chronic pain, FDA(2004)and EMA(2005)[21]
PROTAMINE SULFATE (DB09141)	PROSULF® (CP pharma, Hong Kong, china; Wockhardt Mumbai, India; etc.) PROTAM® (Eipico, Ramadan city, Egypt)	Salmon sperm heads	Biotech (-4.3 kDa)	Reversal of the anticoagulant effect of heparin by forming an inactive complex with heparin	Heparin overdose, FDA(1939)[22.23]
KEYHOLE LIMPET HEMOCYANIN (DB05299)	IMMUCOTHEL® VACMUNE® (Biosyn Corporation,	Keyhole limpet (marine mollusk)	Biotech (350 to 390 kDa)	An immunomodulatory	IMMUCOTHEL for bladder cancer,[24]VACMUNE as protein carrier for vaccine development

	Carlsbad, CA,USA)				[25], the Netherlands (1997), Austria and south Korea (2001),Argentina (2004/2005)[26]
		FISH OIL AND ITS COMPONENTS USED AS DRUGS			
OMEGA-3-ACID ETHYL ESTERS (DB09539)	LOVAZA® (GSK, Brentford, UK) OMACOR® (GSK, Brentford,UK)and OMTRYG® (Trygg Pharma, Oslo, Norway)	Fish	Small molecule (330.51 to 356.55 Da)	Reduces triglyceride synthesis by inhibiting 1,2-diacylglycerol acyltransferase	Reduce triglyceride (TG)levels, FDA (2004)[27-29]
ICOSAPENT ETHYL (DB001559)	VASCEPA ® (Amarin pharma, Dublin, Ireland)	Fish	Small molecule (330.51 Da)	Reduces triglyceride synthesis by inhibiting 1,2-diacylglycerol acyltransferase	Reduces the risk of myocardial infarction, stroke, coronary revascularization and unstable angina, FDA(2012)[30]
OMEGA-3-CARBOXYLIC ACIDS (DB09568)	EPANOVA® (AstraZeneca pharmaceuticals, London, UK)	Fish	Small molecule (302.45 to 328.49 Da)	Reduces triglyceride synthesis by inhibiting 1,2-diacylglycerol acyltransferase	Reduce triglyceride (TG)levels, FDA (2014)[31]
FISH OIL TRIGLYCERIDES (DB13961)	OMEGAVEN® (Fresenius Kabi, bad homburg, Germany)	Fish	Small molecule (mixture of fatty acids, 7000 to 1000 Da each)	Source of calories and essential fatty acids	PNAC,FDA(2018)[32]

Table. : Marketed medications with a marine origin, along with their trade name, place of origin, mode of action, and indication for treating diseases Orphan medications are pharmaceuticals made in industry for uncommon disorders. Their manufacture is not viable due to their need to treat rare illnesses, hence government funding is frequently used to develop them.

Potential Role of Seaweed Polyphenols in Cardiovascular-Associated Disorders-

One third of all fatalities worldwide are caused by cardiovascular diseases (CVDs), which are the primary cause of disease and have a high fatality rate. These cover a variety of conditions affecting the heart and blood arteries, such as coronary artery disease, pulmonary arterial hypertension, deep vein thrombosis, and cerebrovascular illness. Family history, smoking, obesity, dyslipidaemia, diabetes mellitus, and hypertension have all been implicated as key determinants of these disorders, with the latter being the most common cause of CVDs.

Seaweed Polyphenols-

Macroalgae, another name for seaweeds, are a large class of macroscopic organisms that make up a few thousand species in the marine ecosystem. Depending on their colour, seaweeds are divided into three primary phyla: Chlorophyta (green algae), Rhodophyta (red algae), and Phaeophyta (brown algae). The marine macroalgae's colours are attributed to pigments such as fucoxanthin for brown algae, phycobilin for red, and chlorophyll for green. Since ancient times, seaweeds have been prized for their health benefits and have been eaten as sea vegetables in Asian nations. Due to their unique composition, knowledge about the effects of dietary seaweeds on health and wellbeing has recently come to light. Several studies have exposed that seaweeds are not only a good basis of carbohydrates, dietary fibre, proteins and peptides, vitamins, oils, fats, polyunsaturated fatty acid, and minerals, but also contain a large concentration of antioxidants compounds such as polyphenols.

The majority of phytochemicals present in the human diet, including in fruits, vegetables, seeds, essential oils, and foods and beverages made from their derivatives, are polyphenols, a heterogeneous group of chemicals. These plant secondary metabolites range structurally from simple molecules to highly polymerized compounds and comprise many phenolic structures. Based on its biological function, chemical makeup, and origin, the polyphenol family can be divided into different subgroups. To make things easier, polyphenols can be divided into phenolic acids, flavonoids, stilbenes, lignans, and other phenolic compounds based on the chemical makeup of the aglycones. The most widely distributed of these are flavonoids, which can be further broken down into six primary subclasses: flavanols, flavanones, flavones, isoflavones, and anthocyanins. Epidemiological, clinical, and nutritional research all point to the importance of dietary polyphenols in maintaining human health. A lower risk of certain chronic diseases, including as cancer, metabolic and neurological disorders, and CVDs, has been linked to their regular ingestion.

POLYPHENOLS		
PHENOLIC ACIDS 1. Hydroxycinnamic acids 2. Hydroxybenzoic acids	NON FLAVONOIDS 1. Stilbenes 2. Lignans 3. Tannins	FLAVONOIDS 1. Flavone 2. Flavonol 3. Flavanone 4. Flavonol 5. Isoflavone 6. Anthocyanidins
	PHALOROTANNINS 1. Eckols 2. Fuhals 3. Fucophloethols 4. Phloethols 5. Fucols 6. Isofuhals	

Figure. : Classification of polyphenols and the six major subclasses of tannins in algae, the phlorotannin's

Biological Properties of Fucoxanthin in Oil Recovered from Two Brown Seaweeds Using Supercritical CO₂ Extraction-

Together with macro-algae, also known as seaweeds and micro-algae, algae can be divided into two types. Seaweeds are photosynthetic, just like real plants, and they build simple biomasses in the intertidal zones. There are around 9000 different species of seaweed. These species have been broadly categorised into three main groupings of brown (Phaeophyta), red (Rhodophyta), and green (Chlorophyta) seaweeds based on their pigmentation. Unsaturated fatty acids (FAs), polysaccharides, iodine organic products, macro- and microelements, vitamins, and other physiologically bioactive substances are all found in seaweeds. The second-most diverse group of marine algae is made up of about 2000 different species of brown seaweed. The ones that are most frequently employed at the industrial level are *Sargassum* spp., *Laminaria* spp., *Ascophyllum* spp., *Fucus* spp., and *Turbinaria* spp. The complete plant exists as a source of biomass because terrestrial plants have many of the distinct organs that seaweeds lack. Due to their high CO₂ absorption rate in comparison to terrestrial plants, seaweeds have recently received significant attention as viable

biomass sources. Due to the bioactive compounds found in seaweeds, which also have anti-tumour and anti-viral activities, they have high potential for use as antioxidants, antimicrobials, anticoagulants, antithrombotic, and anti-inflammatories in the treatment of many disorders. As a result, seaweeds have been investigated as potential sources for bio-energy, fertiliser, cosmetics, medicine, and feed. Fucoxanthin, a marine carotenoid with exceptional biological capabilities, can be found in marine brown seaweeds, macro algae, and diatoms. Numerous studies have demonstrated that fucoxanthin has great potential and potential use in improving human health. More than 10% of the estimated total production of carotenoids in nature comes from a carotenoid that is plentiful in edible brown algae. This substance contributes to efficient photosynthesis for adaptation to their atmosphere, assisting marine brown algae to persist in shallow coastal waters. It also plays a role in light harvesting and energy transmission. Although the physiological effects of the carotenoids found in seaweeds have received less attention, fucoxanthin has recently received significant attention because of its potent antioxidant qualities against the effects of cancer, hypertension, obesity, and inflammation.

Supercritical Fluid Extraction with Carbon Dioxide:

Figure 3 displays the SC-CO₂ procedure at a lab scale. A 200 mL stainless steel extraction vessel was filled with precisely 100 g of freeze-dried seaweed powder. The extraction vessel was then capped after a thin layer of cotton was placed on top of the sample and at the bottom of the extraction vessel. The extraction vessel was filled with liquid CO₂ using a high-pressure pump (Milroyal; Milton Roy, PA, USA). This was done in order to achieve the appropriate pressure. A back-pressure regulator was used to regulate the CO₂ pressure. The extraction vessel was connected to a water bath to maintain the temperature. The amount of CO₂ used during the extraction process was measured using a gas flow metre (Shinagawa, DC-1, Tokyo, Japan). For the purpose of extracting oil, the seaweeds were examined at a temperature of 45 °C and a pressure of 250 bars. Throughout the whole two-hour extraction time, the CO₂ flow rate remained constant at 27 g/min. Co-solvent ethanol (96%) was employed, flowing at a rate of 1 mL/min. The extracted oil was then taken out of the separator and preserved at 4 °C for later use and analysis after the ethanol had been evaporated in a rotary vacuum evaporator (EYELA N-1100, Tokyo, Japan).

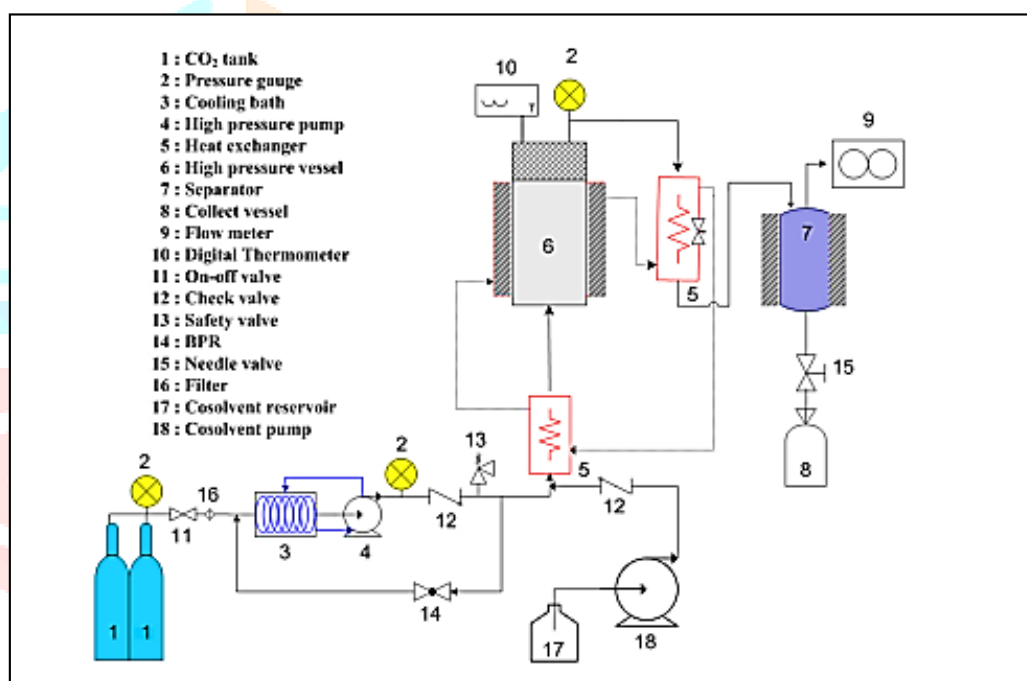

Figure. : Schematic diagram of supercritical fluid extraction with ethanol as co-solvent

CONCLUSION- In marine pharmacology is the identification of the implant or animal marine environment the drugs which are found from marine organisms are known as marine drug in this paper we study the marine medicine deals with the study and the speciality of the marine drug is to prevent the morbidity amongst seafarer in adding principle of sponge cells and many types of cell aggregates delivers an alternative method for manufacturing sponge metabolites.

REFERENCE-

- [1] Author1 LastnameA.F; Author3 LastnameA.F. Title. Container 2000, Volume, pages Used.
- [2] Petit, C.; Sieffermann, J. Testing consumer preferences for iced-coffee: Does the drinking environment have any influence? 2007, 18, 161-172.
- [3] The Textbook of Pharmacognosy.
- [4] Mayer AM, Glaser KB, Cuevas C, Jacobs RS. The odyssey of marine pharmaceuticals: A Current pipeline perspective
- [5] Haefner B, Drugs from the deep: marine natural products as drug candidates, *Drug Discovery Today*, 2003, 8, 536-544.
- [6] Hentschel U, Fieseler L, Wehrl M, Gernert C, Steinert M, Hacker J and Horn M, Microbial diversity of marine sponges. In: *Marine Molecular Biotechnology*, WEG Müller (Ed), Berlin-Heidelberg: Springer-Verlag, 2003, pp. 59-88.
- [7] [Belarbi El Hassan, Gómez Antonio Contreras, Chisti Yusuf, Camacho Francisco García and Grima Emilio Molina, Producing drugs from marine sponges, *Biotechnol Adv*, 2003, 21 (7), 585-598]
- [8] Quitain, A.T.; Kai, T.; Sasaki, M.; Goto, M. Supercritical carbon dioxide extraction of fucoxanthin from *Undaria pinnatifida*. *J. Agric. Food Chem.* 2013, 61, 5792–5797.
- [9] Eom, S.-H.; Kim, Y.-M.; Kim, S.-K. Antimicrobial effect of phlorotannins from marine brown algae. *Food Chem. Toxicol.* 2012, 50, 3251–3255.
- [10] Skov MJ, Beck JC, de Kater AW, Shopp GM: Nonclinical safety of ziconotide: an intrathecal analgesic of a new pharmaceutical class. *Int J Toxicol.* 2007 Sep-Oct; 26(5):411-21. [Article]
- [11] Miljanich GP: Ziconotide: neuronal calcium channel blocker for treating severe chronic pain. *Curr Med Chem.* 2004 Dec; 11(23):3029-40. [Article]
- [12] McGivern JG: Ziconotide: a review of its pharmacology and use in the treatment of pain. *Neuropsychiatr Dis Treat.* 2007 Feb; 3(1):69-85. [Article]
- [13] Bowersox SS, Mandema J, Tarczy-Hornoch K, et al. Pharmacokinetics of SNX-111, a selective N-type calcium channel blocker, in rats and cynomolgus monkeys. *Drug Metab Dispos.* 1997; 25:379–83. [PubMed] [Google Scholar]
- [14] Ellinor PT, Zhang JF, Horne WA, et al. Structural determinants of the blockade of N-type calcium channels by a peptide neurotoxin. *Nature.* 1994; 372:272–5. [PubMed] [Google Scholar]
- [15] Bergmann, W.; Feeney, R.J. Contributions to the study of marine products. XXXII. The nucleosides of sponges I. *J. Org. Chem.* 1951, 16, 981–987. [CrossRef]
- [16] Kremer, W.B. Drugs five years later: Cytarabine. *Ann. Intern. Med.* 1975, 82, 684–688. [CrossRef]
- [17] Glantz, M.J.; LaFollette, S.; Jaeckle, K.A.; Shapiro, W.; Swinnen, L.; Rozental, J.R.; Phuphanich, S.; Rogers, L.R.; Gutheil, J.C.; Batchelor, T. Randomized trial of a slow-release versus a standard formulation of cytarabine for the intrathecal treatment of lymphomatous meningitis. *J. Clin. Oncol.* 1999, 17, 3110–3116. [CrossRef]
- [18] Buchanan, R.A.; Hess, F. Vidarabine (Vira-A®): Pharmacology and clinical experience. *Pharmacol. Ther.* 1980, 8, 143–171. [CrossRef]
- [19] Mayer, A.M. The Global Marine Pharmaceuticals Pipeline. Available online: <https://www.midwestern.edu/departments/marinepharmacology/clinical-pipeline> (accessed on 30 June 2022)
- [20] Chu, M.-Y. Incorporation of arabinosyl cytosine into 2–7S ribonucleic acid and cell death. *Biochem. Pharmacol.* 1971, 20, 2057–2063. [CrossRef]
- [21] World Health Organization; International Society of Hypertension Writing Group. 2003 World Health Organization (WHO)/International Society of Hypertension (ISH) statement on management of hypertension. *J. Hypertens.* 2003, 21, 1983–1992.
- [22] Cardoso, S.M.; Pereira, O.R.; Seca, A.M.; Pinto, D.C.; Silva, A.M. Seaweeds as preventive agents for cardiovascular diseases: From nutrients to functional foods. *Mar. Drugs* 2015, 13, 6838–6865. [CrossRef] [PubMed]
- [23] Heo, S.J.; Park, E.J.; Lee, K.W.; Jeon, Y.J. Antioxidant activities of enzymatic extracts from brown seaweeds. *Bioresour. Technol.* 2005, 96, 1613–1623. [CrossRef] [PubMed]
- [24] Sivagnanam, S.P.; Yin, S.; Choi, J.H.; Park, Y.B.; Woo, H.C.; Chun, B.S. Biological properties of fucoxanthin in oil recovered from two brown seaweeds using supercritical CO₂ extraction. *Mar. Drugs* 2015, 13, 3422–3442. [CrossRef] [PubMed]
- [25] Corona, G.; Coman, M.M.; Guo, Y.; Hotchkiss, S.; Gill, C.; Yaqoob, P.; Spencer, J.P.E.; Rowland, I. Effect of simulated gastrointestinal digestion and fermentation on polyphenolic content and bioactivity of brown seaweed phlorotannin-rich extracts. *Mol. Nutr. Food Res.* 2017, 61. [CrossRef] [PubMed]
- [26] Tierney, M.S.; Smyth, T.J.; Rai, D.K.; Soler-Vila, A.; Croft, A.K.; Brunton, N. Enrichment of polyphenol contents and antioxidant activities of Irish brown macroalgae using food-friendly techniques based on polarity and molecular size. *Food Chem.* 2013, 139, 753–761. [CrossRef] [PubMed]
- [27] Malve, H. (2016). Exploring the ocean for new drug developments: Marine pharmacology. *Journal of pharmacy & bioallied sciences*, 8(2), 83.
- [28] <https://www.slideshare.net/SudheerKandibanPRda/marine-sdrugs-56601492>
- [29] Newswire, P.R. Jazz Pharmaceuticals Announces U.S. FDA Accelerated Approval of zepzelca™ (lurbinectedin) for the Treatment of Metastatic Small Cell Lung Cancer. Available online: <https://www.prnewswire.com/news-releases/jazz-pharmaceuticalsannounces-us-fda-accelerated-approval-of-zepzelca-lurbinectedin-for-the-treatment-of-metastatic-small-cell-lung-cancer-301077082.html> (accessed on 30 June 2022).
- [30] FDA. Blenrep®. Available online: <https://www.fda.gov/drugs/resources-information-approved-drugs/fda-grantedaccelerated-Approval-belantamab-mafodotin-blmf-multiple-myeloma> (accessed on 30 June 2022).
- [31] Brown, D.; Todd, A.; Varadarajan, S. 462. Nucleotides. Part XXXVII. The structure of uridylic acids an and b, and a synthesis of spongouridine (3-*-D*-arabofuranosyluracil). *J. Chem. Soc.* 1956, 2388–2393. [CrossRef]
- [32] Miyashita, K.; Mikami, N.; Hosokawa, M. Chemical and nutritional characteristics of brown Seaweed lipids: A review. *J. Funct. Foods.* 2013, 5, 1507–1517.
- [33] Miyashita, K.; Nishikawa, S.; Beppu, F.; Tsukui, T.; Abe, M.; Hosokawa, M. The allenic carotenoid fucoxanthin, a novel marine nutraceutical from brown seaweeds. *J. Sci. Food Agric.* 2011, 91, 1166–1174
- [34] Lee, J.-H.; Chun, B.-S. Effect of antioxidant activity of mixture obtained from brown seaweed and

Wheat germ oils using different extraction methods. Food. Sci. Biotechnol. 2013, 22, 9–17.

[35] Chandini, S.K.; Ganesan, P.; Bhaskar, N. In vitro antioxidant activities of three selected brown Seaweeds of India. Food Chem. 2008, 107, 707–713.

[36] Luo, H.-Y.; Wang, B.; Yu, C.-G.; Qu, Y.; Su, C. Evaluation of antioxidant activities of five selected Brown seaweeds from China. Med. Plants. Res. 2010, 4, 2557–2565.

[37] Rauck RL, Wallace MS, Leong MS, et al. A Randomized, Double-Blind, Placebo-Controlled Study of Intrathecal Ziconotide in Adults with Severe Chronic Pain. J Pain Symptom Manage. 2006; 31:393–406. [PubMed]

[Google Scholar]

