



## “A STUDY ON ENERGY GENERATION FROM THE TRAFFIC WIND MILLS FOR SMART ROAD NETWORK”

<sup>1</sup>Prof.Manjunath Sharanappanavar, <sup>2</sup>Rutuja Kusannavar, <sup>3</sup>Rashmi Meled, <sup>4</sup>Shivani Nandagadkar,

<sup>5</sup>Megha Mastamardi

<sup>1</sup>Assistant professor, Department of Civil Engineering, SGBIT, Belagavi. <sup>2,3,4,5</sup>Final year students of bachelor of engineering, department of civil engineering, SGBIT, Belagavi.

Email.ID: <sup>1</sup> [sharanappanavarmanju@gmail.com](mailto:sharanappanavarmanju@gmail.com), <sup>2</sup> [rutu10699@gmail.com](mailto:rutu10699@gmail.com), <sup>3</sup> [meledrashmi@gmail.com](mailto:meledrashmi@gmail.com), <sup>4</sup> [nadagdkarshivani8@gmail.com](mailto:nadagdkarshivani8@gmail.com), <sup>5</sup> [megharmastamardi96@gmail.com](mailto:megharmastamardi96@gmail.com).

### Abstract:

Wind power is one of the rarest and most abundant forms of energy. Electricity can be generated with the help of a vertical wind turbine. This project aims to use this wind energy more efficiently to generate more electricity, so we have chosen the highway as our input area where we can take advantage of the traffic on both sides of the road. In the current operation, the turbine is designed and designed as specified, the blades used are semi-circular and connected to a disk attached to the shaft. The shaft is connected to the pulley with the aid of a bearing, and the pulley is connected to an alternator, which generates power. Enhanced power is stored in the battery and can be used in street lighting, signal or toll. In this project a small model was created for testing purposes. The project also aims to produce high cost at low cost, so that the government can think about the project and be able to use this type of axis wind turbine on highways at low cost.

### 1. INTRODUCTION

#### 1.1 Wind turbine

As human population grows and our natural resources suffer from increasing demand, it is more important than ever to invest in renewable energy. Our use of fossil fuels as energy has been tracked as a leading cause of environmental issues. The result of the use of fossil fuels is carbon dioxide, which has been named as a major contributor to global warming.

There are only a few types of energy that do not produce carbon dioxide. These are nuclear power and renewable energy sources such as wind, solar, and water. Renewable energy sources are the cleanest of these sources, as no waste is produced as a by-product of these sources.

The motivation for this project is to contribute to the global trend towards clean energy in a feasible way.

#### 1.2 Wind turbine classification

There are two main types of wind turbines. The two most common categories of wind turbines include vertical axis or horizontal axis wind turbines. Turbines are classified by the way the generator shaft is positioned. The horizontal axis wind turbine HAWT was developed before the vertical axis wind turbine

(VAWT), which led to its popularity and widespread use.

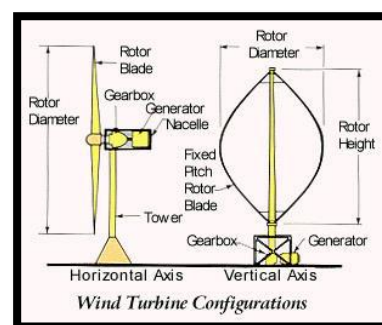

Fig:1.1 showing the classification horizontal

and vertical wind axis wind turbine

- i. Horizontal axis wind turbine  
Horizontal wind turbines (HAWT) have a main rotor line and an electric generator at the top of the tower, and must be pointed in the air. Smaller turbines are equipped with a simple air valve, while larger engines usually use a wind sensor connected to a servo motor. Most have a gearbox, which converts slow-moving blades to a fast turn ready to drive an electric generator. As the tower produces chaos behind it, the turbine is usually placed at the top of its supporting tower. Turbine

blades are made stronger to prevent blades from being pushed into the tower due to high winds. In addition, the blades are placed a long distance in front of the tower and are sometimes tilted forward in the air for a small amount.

Rotor, torque and speed characteristics can be controlled and improved on modern HAWT by changing the pitch angle of the rotor blades. It can be done using mechanical or electronic blade pitch control system. This process improves wind turbine performance while protecting the turbine from extreme wind conditions and higher speeds.

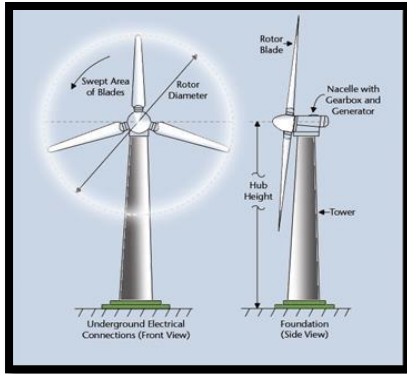

FIG: 1.2. Typical Horizontal axis wind turbine

## ii. Vertical wind turbine axis

Vertical axis turbines (or VAWTs) have a main rotor line arranged directly. Another advantage of this arrangement is that the turbine does not need to be pointed in the air in order to operate, which is an advantage in an area where the direction of wind varies widely, for example when a turbine is connected to a structure. Also, a generator and gearbox can be installed near the ground, using a direct drive from the rotor assembly to the ground gearbox, to improve accessibility. Fig.no 1.3 shows the wind axis of a normal wind turbine.

1. Savonius Type Windmill (1920): - Contains half-cylinders facing opposite sides in such a way that they have about half an S-shaped cross. The two circular drums are mounted on a vertical axis with a gap in the axis between the two drums.



FIG:1.3. Savonius Type wind turbine

2. Darrius (High-Speed Wind Machine) (1905): - A modern circular propeller-type wind turbine using an efficient way to cut a large air area with a small blade

area. It has 2 or 3 curved blades with cross-section of airfoil and continuous chord length. Both ends of the blades are connected to a straight shaft. So the power on the blades due to the rotation is strong. This gives strength to help withstand the force of the wind, it meets. So blades can be made simpler than the type of propeller. An added benefit is that it supports its blades in a way that minimizes bending stress in normal operation.



Fig.1. 4. Typical Vertical axis wind turbine

## 2. LITERATURE REVIEW

### 2.1 D.A Nikkam 2015, Design and Development of Vertical Axis Wind Turbine Blade

D.A. Nikam et al. analyzed the literature review on design and development of vertical axis wind turbine blade. This paper explains that the wind mill such as vertical and horizontal wind mill is widely used for energy production. The horizontal wind mill is highly used for large scale applications which require more space and huge investment. Whereas the vertical wind mill is suitable for domestic application at low cost. The generation of electricity is affected by the geometry and orientation of the blade in the wind turbine. To optimize this by setting the proper parameter for the blade design. The experimental result indicates that the blade plays critical role in the performance and energy production of the turbine. The optimized blade parameter and its specification can improve the generation of electricity.

### 2.2 Dr. BOESL 2013, Highway Wind Turbines

Extensive data is collected on wind patterns produced by vehicles on both sides of the highway. Using the collected data, a wind turbine is designed to be placed on the medians of the highway. Although one turbine may not provide adequate power generation, a collective of turbines on a long strip of highway has potential to generate a large amount of energy that can be used to power streetlights, other public amenities or even generate profits by selling the power back to the grid. This design concept is meant to be sustainable and environmentally friendly. Additionally, a wind turbine powered by artificial wind has a myriad of applications. Theoretically any moving vehicle can power the turbine such as an amusement park ride. The highway wind

turbine can be used to provide power in any city around the globe where there is high vehicle traffic.

### 2.3 Dr Hettiarachchi N. K 2014, Design, Fabrication and testing of VAWT with wind deflectors

Extensive data is collected on wind patterns produced by vehicles on both sides of the highway. Using the collected data, a wind turbine is designed to be placed on the medians of the highway. Although one turbine may not provide adequate power generation, a collective of turbines on a long strip of highway has potential to generate a large amount of energy that can be used to power streetlights, other public amenities or even generate profits by selling the power back to the grid. This design concept is meant to be sustainable and environmentally friendly. Additionally, a wind turbine powered by artificial wind has a myriad of applications. Theoretically any moving vehicle can power the turbine such as an amusement park ride. The highway wind turbine can be used to provide power in any city around the globe where there is high vehicle traffic.

### 2.4 P.Kartikeyen et al 2019, Design and development of ENLIL turbine for highways electrification.

ENLIL is a vertical axis wind turbine that transforms highways into renewable energy sources by using the dynamics of the city. Enlil will generate energy by using the winds created by the vehicles as well as the natural winds. This turbine uses the wind pressure generated by the fast-moving vehicles on roads such as big trucks and busses that helps to rotate its blade. It is designed with vertical long blades such that it will use the utmost quantity of wind energy.

### 2.5 Samir j, deshmkh et.al 2017, Design and development of vertical axis wind turbine.

His paper gives ideas to learn about the design and fabrication of complex Aero foil blades. Vertical axis wind turbine represents a very promising future for wind power generation. A vertical wind turbine can give output more than conventional HAWT. The rotor that is designed to harness enough air to rotate the shaft at low and high wind speeds. The efficiency of turbine is increased by proper designing of the aero foil shape blade; the major components are placed at the ground level which ensures the safety of turbine. Thus, it can be concluded that Vertical axis wind turbine can produce power more with higher efficiency compared to traditional wind turbine. At a very low speed wind velocity thus, this technology has the capacity to completely displace current technology in use for wind farms.

## 3. PARAMETERS

- 1) Speed
- 2) Start up speed
- 3) Cut in speed
- 4) Voltage regulation
- 5) Battery bank voltage
- 6) Inefficiency
- 7) Blade material
- 8) Number of blades
- 9) Diameter
- 10) Tip speed ratio
- 11) Taper
- 12) Pitch and Twist
- 13) Bearing

## 4. DATA COLLECTION

### 4.1 Traffic Volume Count

The Traffic Volume Count counts the number of vehicles passing through the road over a period of time. It is usually presented in terms of the Passenger Car Unit (PCU).

#### Purpose of Traffic Volume Count

The purpose of traffic volume calculation is to draw an estimate based on the data collected. Provide possible solutions and a proposal for the development of a identified problem. The objective included includes identifying the hourly and hourly traffic distribution, identifying the level of service and comparing modal shapes to different road arrangements. Following are the Summery sheets of traffic volume count.

Table 4.1: Showing the summary sheet of Traffic volume count from Bogarves circle to Chennai circle

Date	Time	Two wheeler	3 wheeler	4 wheeler	LCV	HCV	Bus
8/01/22	8:00am-8:00pm	19332	3984	3388	824	646	687
8/01/22	8:00am-8:00pm	18248	3848	3525	787	597	666
9/01/22	8:00am-8:00pm	18734	4611	3194	1091	740	711
9/01/22	8:00am-8:00pm	19287	3808	3312	1107	703	771

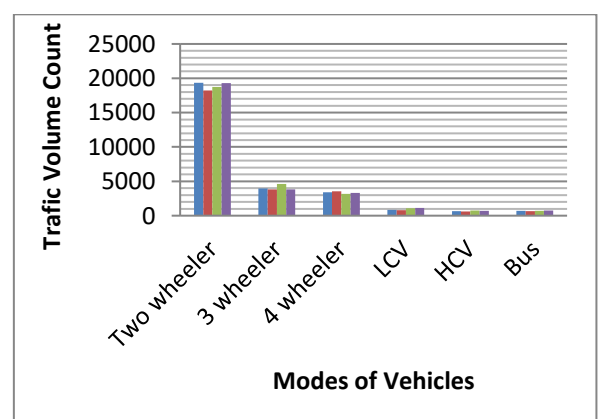

Figure 4.1 : Graphical representation of Traffic volume count from bogarves circle to chennama circle

Table 4.2: Showing the summary sheet of Traffic volume count from RTO circle to Chennai circle

Date	Time	Two wheeler	3 wheeler	4 wheeler	LC V	HC V	Bu s
15/01/22	8:00am - 8:00pm	16174	3908	4094	1040	655	690
15/01/22	8:00am - 8:00pm	15106	5037	4282	848	642	640
16/01/22	8:00am - 8:00pm	17250	3908	3838	1228	843	706
16/01/22	8:00am - 8:00pm	15735	5473	5030	2465	1497	866

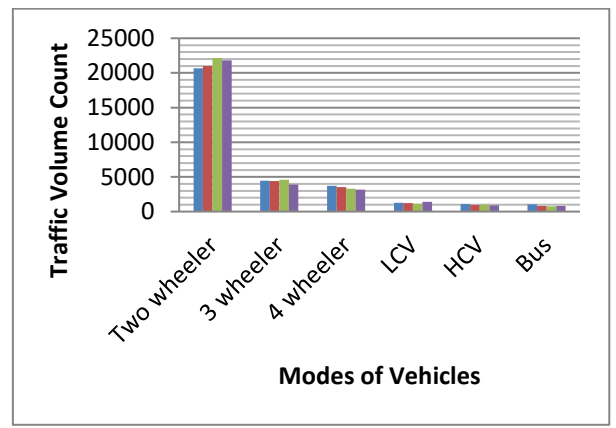

Figure 4.3: Graphical representation of Traffic volume count from RTO circle to Chennai circle

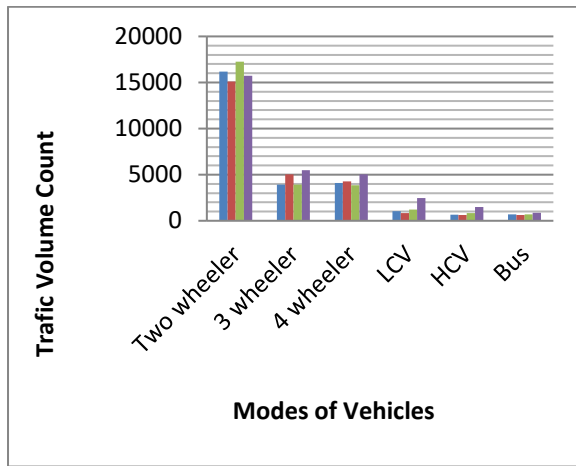

Figure 4.2 : Graphical representation of Traffic volume count from RTO circle to Chennai circle

Date	Time	Two wheeler	3 wheeler	4 wheeler	LC V	HC V	Bus
22/01/22	8:00am - 8:00pm	20678	4439	3719	1291	1067	1039
22/01/22	8:00am - 8:00pm	20990	4395	3537	1236	936	814
23/01/22	8:00am - 8:00pm	22152	4612	3312	1129	984	780
23/01/22	8:00am - 8:00pm	21799	3896	3181	1392	900	800

Table 4.3: Showing the summary sheet of Traffic volume count from Kolhapur circle to Chennai circle

#### 4.2 Speed survey

Speed surveys were conducted to measure the distribution of traffic speeds in a traffic source somewhere on the highway.

Speed testing can be done manually or through tubes placed across the road known as ‘automatic traffic counters’ (ATC’s). Manual speed surveys often provide a more accurate indication of vehicle speed as they include features such as weather, obstacles in free flow conditions, high-speed emergency vehicles, and removal of traffic ‘clusters’ in the study. ATCs are available 24 full hours, a seven-day period and thus receive a large range of results and traffic flow. However due to their nature they will not consider the features a conductor can record as part of a personal study.

SL.NO	2 WHEELER	3 WHEELER	4 WHEELER	LC V	HCV	Buses
Distance (km)	1.4	1.4	1.4	1.4	1.4	1.4
Avg. Time (hrs)	0.0182	0.020	0.0148	0.022	0.020	0.023
Avg. velocity (km/hr)	78.56	67.78	64.893	66.33	70.59	61.14
In m/sec	21.82	18.82	18.02	18.42	19.60	16.98

Table No-3.4 showing the summary sheet of speed survey from Chennai circle to RTO circle

SL.NO	2 WHEELER	3 WHEELER	4 WHEELER	LCV	HC V	Buses
Distance (km)	1.4	1.4	1.4	1.4	1.4	1.4
Avg. Time (hrs)	0.0193	0.020	0.0168	0.020	0.026	0.021
Avg. velocity (km/hr)	78.94	67.70	85.96	72.59	56.97	64.33
In m/sec	21.92	18.80	23.87	20.16	15.82	17.86

Table No-3.4 showing the summary sheet of speed survey from RTO Circle to Chennai circle

## 5. DESIGN PARAMETERS

Velocity of Wind,  $V = 7 \text{ m/s}$   
 Length of blade,  $l = 0.226 \text{ m}$   
 Breadth,  $b = 0.077 \text{ m}$   
 Area of Blade =  $l \times b = 0.0174 \text{ m}^2$   
 Power generated-150 w  
 Rated wind speed-6.5 m/sec  
 Aspect ratio-8.91  
 Solidity-16.66  
 Diameter-Height-300mm300m  
 Number of blades-3

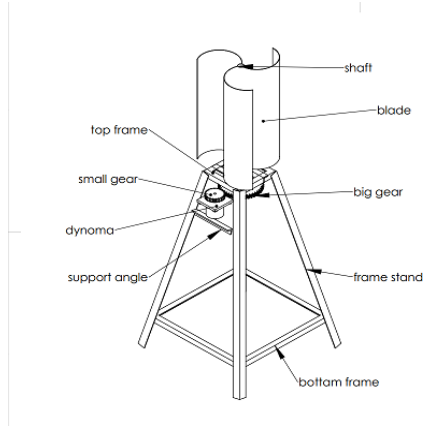

Figure 4.4 showing the parts of wind mill

## 6. COMPONENTS

1. Angle
2. Dynamo
3. Gear
4. Shaft
5. Blades
6. Nut ,Bolts and Washer
7. Bearing
8. Other attachments
9. Wiring

## 7. RESULT AND CONCLUSION

1. Based on the traffic surveys, data collected and data analysis Amount of Traffic in the Study Area found per day as -56532 numbers of vehicles from bogarves to chennamma circle, from RTO circle to chennamma circle-53116 numbers of vehicles and for chennamma circle to kollhapur circle is- 64141 number of vehicles.

Average velocity found as 18.94 from chennamma circle to RTO Circle and 19.73 is for RTO Circle to chennamma circle.

2. Traffic Wind Mills for the Smart Road Network is designed with following specification.

- Height of wind turbine=1400mm
- Height of blade = 500mm
- Velocity of wind = 7m/s
- Diameter of shaft = 25mm
- Numbers of blade = 3 no's

3. Fabrication of the Traffic Wind Mills for the Smart Road Network is done with the following specifications.

- Height of wind turbine=1400mm
- Height of blade = 500mm
- Velocity of wind = 7m/s
- Diameter of shaft = 25mm

4. By referring our whole study on ENERGY GENERATION FROM THE TRAFFIC WIND MILLS FOR SMART ROAD NETWORK'' we conclude that a sufficient amount of mixed traffic is found using which traffic wind mills can be operated effectively with 71 watt by using multi meter device which can be used for the light poles for public use which intern decreases burden on service providers of power supply to the public.

## 8. REFERENCES

- [1]Dr. Hettiarachchi N.K., Jayathilake R.M., Sanath J.A. "Performance Simulation of a Small Scale Vertical Axis Wind Turbine (VAWT) with the Integration of a Wind Deflector System", Department of Mechanical and Manufacturing Engineering, Faculty of Engineering, University of Ruhuna, Mar 19, 2014
- [2]. Wind turbine [online].Viewed 2014 June
- [3].The-Importance-Of-Wind-Energy [Online]. Viewed 2014 June 04.
- [4].Vertical axis wind turbine [online].Viewed 2014 June 4.
- [5]. Computing forces, moments and the center of pressure. [Online] . Viewed 2014 September 25.
- [6]J.P.Baird, S.F Pender, "Optimization of a vertical axis wind turbine for small scale applications", 7th Australian Hydraulics and Fluid Mechanics Conference, Brisbane, 18-22 August 1980.
- [7]. Power in the wind [online]. Viewed 2014 December 20.
- [8].P.Kartikeyen et al 2019, Design and development of ENLIL turbine for highways electrification.
- [9]. Samir j, deshमुख et.al 2017, Design and development of vertical axis wind turbine.
- [10]. Sahishnu R Shah, Rakesh kumar(2018) Design, modeling and economic performance of a vertical of a vertical axis wind turbine.