



PERFORMANCE ANALYSIS OF DIFFERENT MPPT CONTROL METHODS USING BOOST CONVERTER FOR PHOTOVOLTAIC SYSTEMS

1st S. Vijai Ananth¹, 2nd S. Singaravelu²

1st Research Scholar ¹, 2nd Professor ²

1st Department of Electrical and Electronics Engineering, Annamalai University, Tamilnadu, India,

2nd Department of Electrical and Electronics Engineering, Annamalai University, Tamilnadu, India

ABSTRACT: PV systems were turned-out as efficient and satisfying way of electrical energy production for urban electrification in all over the world. As the power generated by a PV cell in directly depending on the climatic condition such as temperature and irradiation. Although the direct PV generated power can not be utilized by load due to its instability and fluctuations. Now a day's researches are concentrating of efficient power point tracing MPPT methods to operate the PV system at its maximum efficiency. This paper presents the competitive analysis of different MPPT controller like P&O, INC and ANFIS methods. This proposed PV system applied different MPPT methods using DC to DC boost converter with resistive load. The proposed PV system has done using Matlab/Simulink platform to many efficiencies, Accuracy, ripple as a comparison of above mentioned MPPT methods.

Index terms- MPPT, PV Cell, P&O, INC, ANFIS, Matlab/Simulink

I. INTRODUCTION

The future electrical energy needs, cannot be fulfill by conventional energy resource due to its demand and raising price. The concentration on non-conventional energy resource are increased by researches to develop the innovative electricity generation system using solar, wind, Tidal, Biomass etc.[1].Among the other non-conventional energy resource solar energy plays virtual role but it has limitations due to change in insulation conditions. The solar power system is now operated with variation of maximum power point tracking methodologies to extract maximum efficiency. Among the varies type of MPPT controller it is not known how many of these are operating efficiency at varying climatic condition [2]. This paper is aimed to integrate the accuracy and stability of globally occurred these major MPPT methods at different temperature and irradiance level using dc to dc boost converter with different circuits [2]. In this paper, perturb & Observe algorithm [INC] and ANFIS MPPT methods on proposed for investigation of performance of various climatic conditions. The MPPT not only increase the stability of PV power but also enhance the operating life time of PV system. In order to utilize the proposed MPPT methods using Matlab/Simulink platform, the PV array is modeled in on environment including converter for load[3].The proposed PV system includes a 1KW PV paneled-DC boost converter, load and MPPT controller will involved for a comparative analysis.

MATHEMATICAL MODEL OF 1KW PV SYSTEM

PV system consist of a 1kw solar array dc-dc boost converter mppt control load and sensors, these are different types of dc to dc converter are available to transform the generated PV power to load. But the selection of exact type of dc-dc converter depends On the proposed system voltage level involved .In this paper a dc to dc boost converter with dc filter in PV system side is involved [3].The equivalent circuit formation of a PV cell is discussed below.

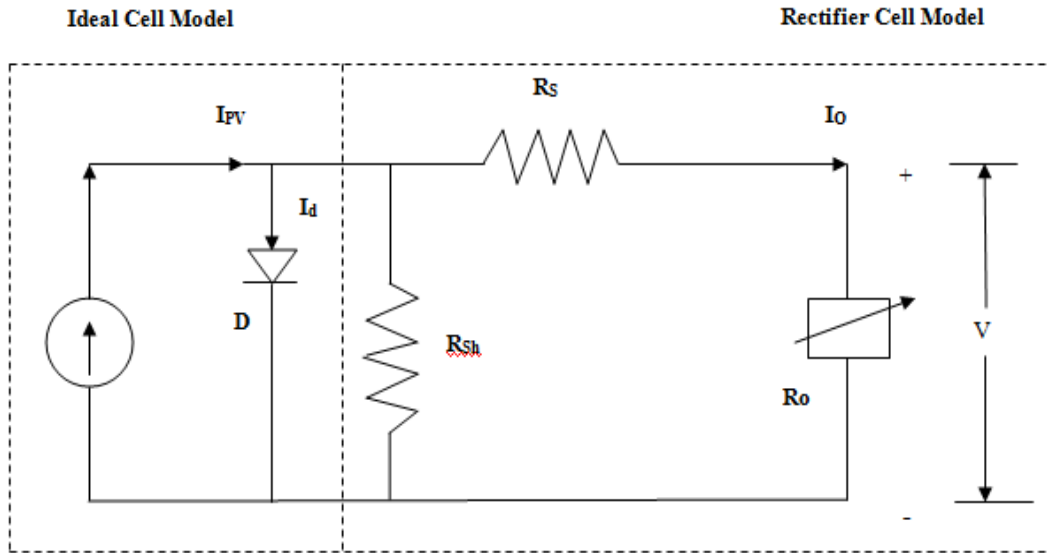

Figure 1. Equivalent circuit of solar cell

Figure 1. Shows the equivalent circuit model of single diode solar cell. Here R_o is load resistance, R_s is the series resistance and R_{sh} is the shunt resistance. The current of PV cell can be equated by, (2.1)

$$I_o = I_{scr} / [e^{qV_o/kT} - 1] \quad (2.1)$$

Where,

I_{scr} – Is the short circuit current generated by photon

k – Is the Boltzmann's constant

T – Is the cell operating temperature in Kelvin (k)

q – Is the charge of the electron

V_o – Is the open circuit voltage

n_s and n_p are number of starting connected in series and parallel respectively. Where n_s , decides the voltage and n_p decides the current requirement of PV panel. The series PV cells connected together to form one starting. The series and parallel connection of starting from array [4]. The output current of PV module is given as, (2.2)

$$I_o = n_p I_{ph} - n_p I_{sr} [e^{(k \times \frac{V_o}{n_s})} - 1] \quad (2.2)$$

Where,

I_o – PV array output current

V_o – PV array output voltage

I_{pv} – Current generated by PV cell which is directly proportional to solar irradiation (w/m²)

I_{sr} – Cell reverse saturation current and it depends on temperature (T)

K_o – Constant

$K_o = q/kTA$

Where A is p-n junction Ideality factor [4]. From equation (ii) I_{pv} is calculated as follows, (2.3)

$$I_{pv} = [I_{scr} + k_i(T-T_0)]G/100 \quad (2.3)$$

Where,

G-Irradiance (w/m²)

T- Cell operating temperature

T₀-Reference temperature

K_i-Shotr circuit current co-efficient

The reverse saturation current I_{sr} is calculated as, (2.4)

$$I_{sr} = I_{rr}[T/T_0]e(qE_g/K_A[1/T_0-1/T]) \quad (2.4)$$

Where, I_{rr} is reverse saturation current at T₀, E_g is band gap energy of semiconductor recommended in the cell. By changing T, G, n_s, n_p and V_{pv} any of their five parameters, a specific PV module can be simulated. The electrical specification of the 1kw PV system is shown in table 1.

Table 1. PV array specifications

SL.NO.	PARAMETER	VALUE
1	Number of parallel string	4
2	Number of series string	1
3	Maximum Power [P _{max}]	1000W
4	Array Voltage at [V _{mpp}]	119.6V
5	Array current at [I _{mpp}]	8.35A
6	Array open circuit voltage[V _{oc}]	148.4V
7	Array short circuit current[I _{sc}]	8.92A
8	V _{oc} Temperature co-efficient	-0.32%/°C
9	I _{sc} Temperature co-efficient	+0.04%/°C

DC-DC boost converter is extracted from power converter family is constructed with inductor, diode, IGBT as a switch output capacitor and load. The inductor current increase only when switch is closed and if the switch is opened both inductor voltage and supply voltage

are directed through load. These the higher output voltage is appeared across the load [5]. The Simulink model of proposed boost converter is shown in figure 2.

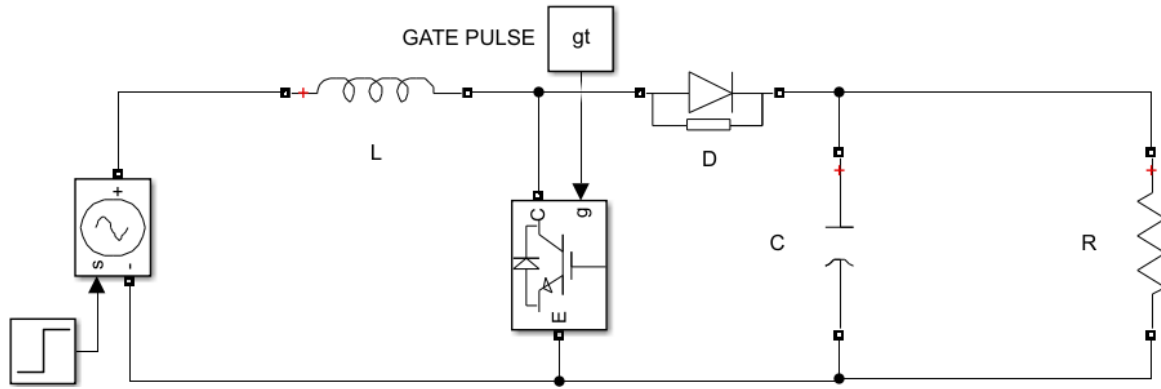

Figure 2. Simulink model of dc-dc boost converter

II. MPPT METHODS

2.1. Perturb And Observe Method

This algorithm does not require previous knowledge of PV generator characteristic and it is easy to implement [6]. In this type the power stability is maintained by varying supply voltage. In this method the output power is continuous measured and composed with previously measured power. As the name implies this method is based on the perturbation of the system by increasing/decreasing the duty cycle for the boost converter and then observing the change on the output power to make possible change on duty cycle. If the

values of current power P_k of the generator is greater than the last value P_{k-1} then the same some previous algorithm direction is maintained otherwise the perturbation direction of P&O algorithm is shown in figure 3.

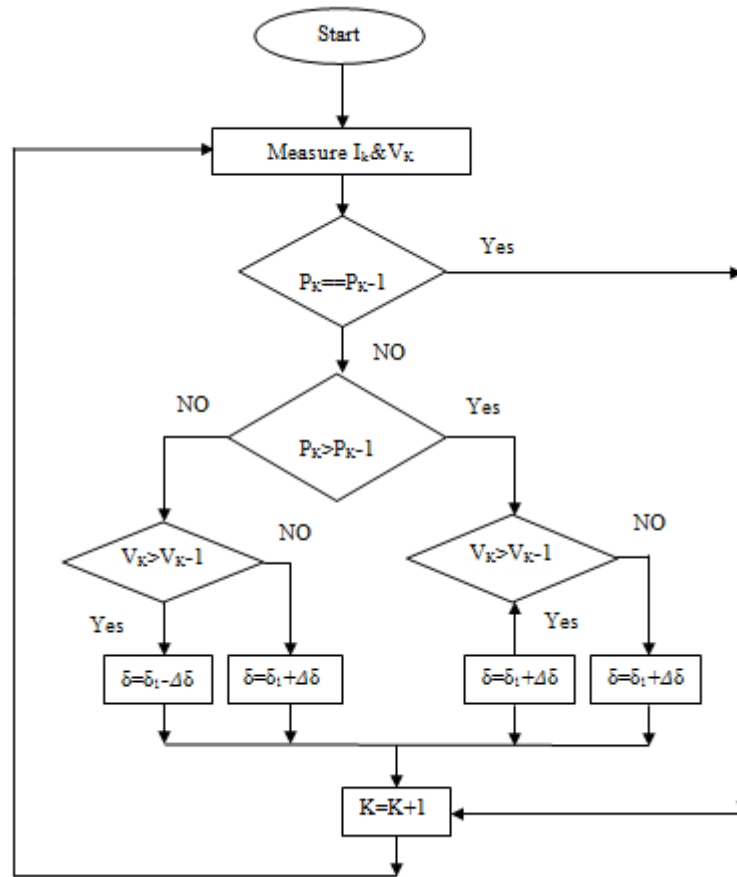

Figure 3. Flowchart of the P & O algorithm

3.2 Incremental Conductance Method

This method uses the slope of PV array power characteristics to track the maximum power as shown in figure.4. Incremental conductance method is based on the truth that the slope of PV array power curve is zero at maximum power point ($dp/dv=0$) positive for values of output power smaller than maximum power point ($dp/dv>0$) and negative for values of the output power greater than maximum power point ($dp/dv<0$) [7][8]. On the derivative of the array power is zero the tracking power is ended but is not easy to maintain the system stable at bad weather conditions due to frequent change in temperature and irradiance levels. Now a day's variable step-size or adaptive

step size INC methods are induced and extract maximum power without fluctuation for a PV array the generalized power equation is given as, (3.1)

$$P_{pv} = I_{pv} \times V_{pv} \quad (3.1)$$

Where,

I_{pv} =Array current

V_{pv} =Array voltage

P_{pv} =Array power

INC method is based on differentiation of power with respect to voltage and equate it to zero in equation (3.2)

$$D(P_{pv})/d(V_{pv}) = d(I_{pv} \times V_{pv})/dV_{pv} = I_{pv} \times dV_{pv}/dV_{pv} + V_{pv} \times dI_{pv}/dV_{pv} = 0 \quad (3.2)$$

$$dI_{pv}/dV_{pv} = -I_{pv}/V_{pv} \quad (3.3)$$

The above equation (3.3) it is clear that I_{pv}/V_{pv} is nothing but Instantaneous conductance and dI_{pv}/dV_{pv} is Incremental conductance and in the power curve slope where these two values are equal in said to be maximum power point region.

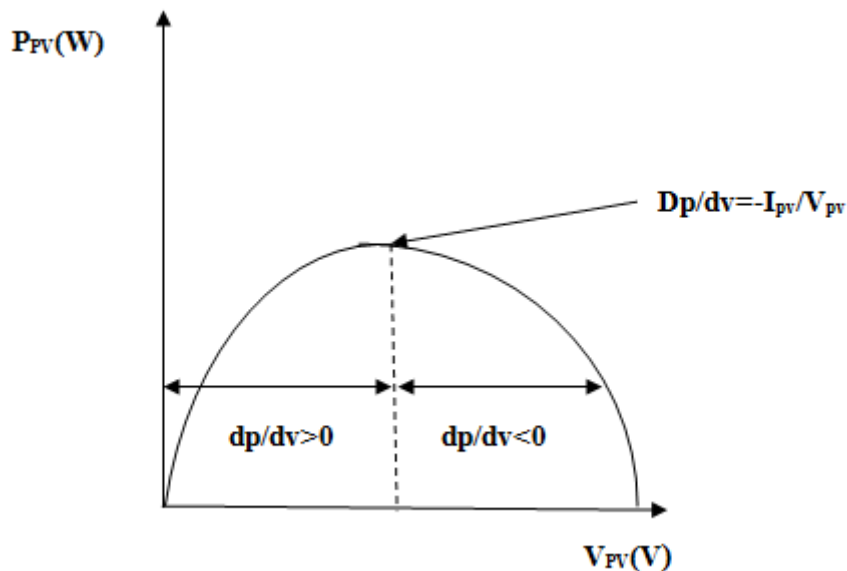

Figure 4. PV curve of PV array

In each sample the operating point of maximum power point evaluated as there groups,

$$d P_{PV}/dV_{PV} > 0; \text{ Which means } V_{PV} < V_{mpp} \quad (3.4)$$

$$d P_{PV}/dV_{PV} = 0; \text{ Which means } V_{PV} = V_{mpp} \quad (3.5)$$

$$d P_{PV}/dV_{PV} < 0; \text{ Which means } V_{PV} > V_{mpp} \quad (3.6)$$

The algorithm of the Incremental Conductance method is shown in figure 5.

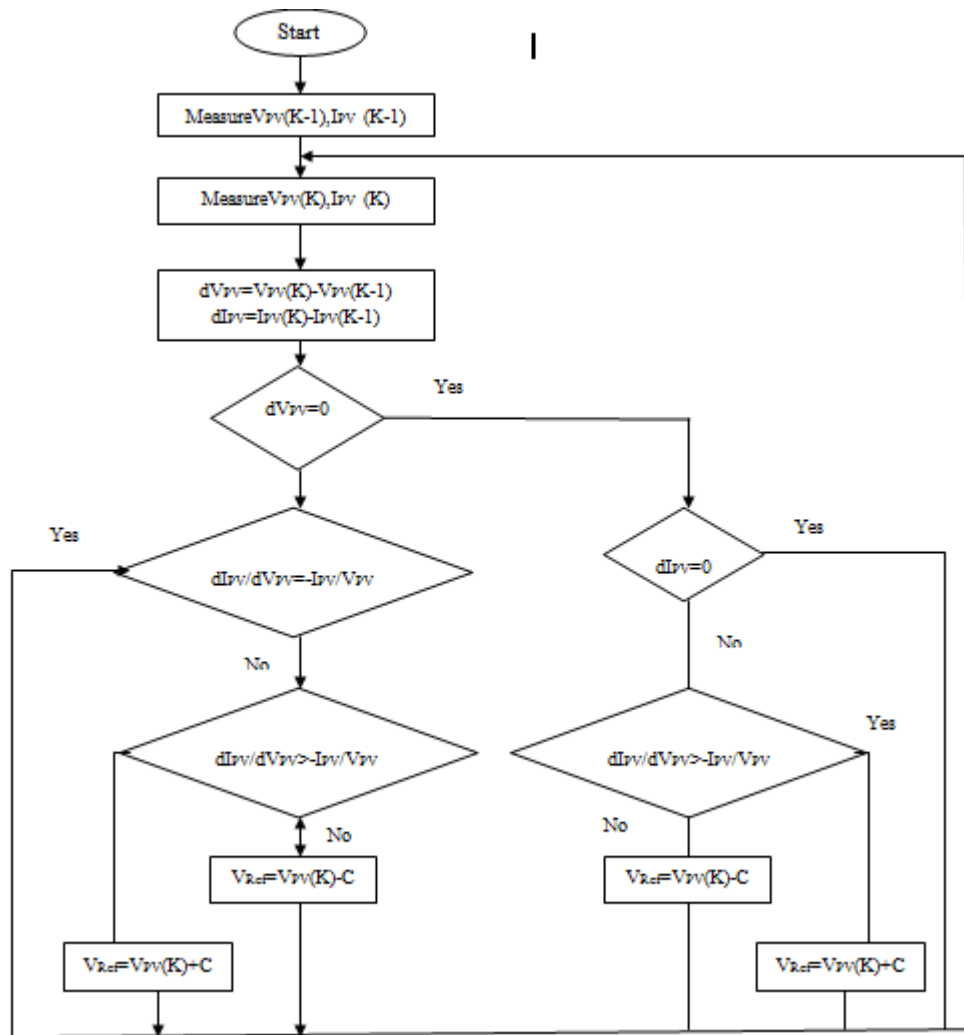

Figure 5. Flowchart for INC algorithm

The major advantage of INC method is that it is more stable and compactable with rapidly changing climatic conditions [9].

3.3 ANFIS Maximum Power Point Tracking Technique

3.3.1 Mppt Design

ANFIS is a control technique for Sugeno-type fuzzy systems. It is a combination of two learning techniques such as ANN and FUZZY logic system into a single machine. ANN is based on statistics training, while fuzzy logic is based on skilled knowledge. ANFIS has a feature of input-output mapping of training data sets when it is trained with enough number of epochs [10]. After the values of membership functions are adjusted one, the developed ANFIS model becomes a learned model which is ready to be used for the solar maximum PowerPoint tracking application [11]. This technique has six layers including 0th layer (input layer).

They are as follows:

Layer 0: Input layer which is passive in nature. In this layer PV array voltage and current are provided as the input.

Layer 1: Inputs are provided for each individual nodes N1 to N7 i.e., for 7 nodes. It is also called as membership layer, where all the neurons are provided with the membership data pattern values. 7 linguistic variables that are used for the fuzzy theory to describe the

membership functions. Relation between input and output membership functions of this layer are denoted by Equation (3.7) and Equation (3.8)

$$Y_{1i}^1 = \mu_i N_i (\theta) \quad i = 1, 2 \dots 7 \quad (3.7)$$

$$Y_{1j}^1 = \mu_j N_j (\theta') \quad j = 1, 2 \dots 7 \quad (3.8)$$

Where, Y_{1i}^1, Y_{1j}^1 represents the layer 1 output nodes and, $\mu_i N_i, \mu_j N_j$ represents the layer 1 membership functions. Memberships are bell shaped with maximum value 1 and minimum value 0. Bell shaped membership functions represented by Equation (3.9) and Equation (3.10) with the required parameters.

$$F(\theta; A B C) = \frac{1}{1 + \left| \frac{\theta - C}{A} \right|^{2B}} \quad (3.9)$$

$$F(\theta'; A B C) = \frac{1}{1 + \left| \frac{\theta' - C}{A} \right|^{2B}} \quad (3.10)$$

Where, A, B parameters vary the width of the curve and the parameter C locates the center of the curve. For this, the parameter B should be positive. A, B and C parameters are also said to be as premise parameters. This layer checks the weight of each membership function. It takes all its inputs from the 0th layer and computing the membership values specified the degree to all the input pattern values. Here all crisp values are converted into fuzzy sets by the process called fuzzification.

Layer 2: Pre-condition matching of fuzzy rules is performed using Equation (3.11) in this layer, i.e., activation level of each rule gets computed in this layer. Number of fuzzy rules decides the number of layers in the model. All pattern values are fired and those fired values are normalized in this layer. Neurons receive the input information from the previous layers, which represents the fuzzy sets. If neurons have a greater number of inputs, then the conjunction of all rules is processed by fuzzy operation. This operation is used to combine the multiple inputs to form suitable fuzzy rules. Here, the numbers of neurons that are processed are 49.

$$Y'_2 = \mu M_i (\theta) \text{ And } \mu M_i (\theta') \quad (3.11)$$

Layer 3: This layer is also called as Norm layer, which provides the output values from the weighted sum of previous inputs from inference of the rules. Each neuron of this layer performs the normalization, and those outputs are called normalized firing strengths that are given by Equation (3.12)

$$Y_3' = \frac{Y'_2}{\sum_i Y_{2i}'} \text{ Where } i=1, 2, \dots, M \quad (3.12)$$

It is a fixed node where it also calculates the ratio of ith rule activation level to that of all fuzzy rules.

Layer 4: This layer integrates the weighted sum of previous inputs. It is an adaptive node that calculates the contribution of ith rule towards the overall output, i.e., in this defuzzification process of fuzzy system takes place with the weighted average method. So, it gives the crisp output by defuzzifying of the entire layer's fuzzy output. ANFIS applies a standard defuzzification process by including

the centroid technique. And the overall output is represented in Equation (3.13). In this layer all the neurons are trained by least square estimation to produce the optimum output.

$$Y_4' = Y_3' = \sum_{i=1}^M M_i \theta + N_i \theta' + R_i \text{ where } i = 1, 2, \dots, M \quad (3.13)$$

Where, $M_1, M_2, \dots, M_M, N_1, N_2, \dots, N_M$ and R_1, R_2, \dots, R_M are the consequent parameters of the layer.

Layer 5: It has a single neuron that produces the final output that has the weighted sum of all integrated outputs of the previous layers and hence termed as an Output layer. Then the final output is given by Equation (3.14)

$$Y_5' = \sum_i Y_4' \quad (3.14)$$

Where,

Y_5' is the 5th layer output and Y_4' is the 4th layer output.

The output of ANFIS model is the change in duty cycle ΔD . ANFIS MPPT coding is done on MATLAB m-file to create ANFIS file [12]. The ANFIS structure created in simulation's shown in Figure 6. The steps involved for creating a simulation model is as follows:

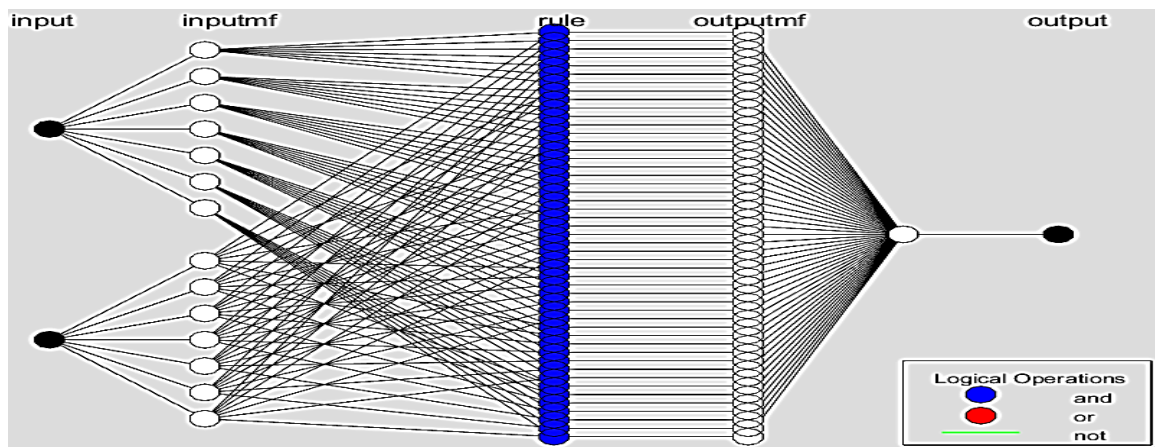

Figure 6. ANFIS structure generated by the matlab

Step 1: Generation of Training And Checking Data

1KW solar array with load resistance is simulated in MATLAB/ SIMULINK which is presented in chapter 2 for the condition from open circuit to short circuit by varying load resistance. Input-output pairs of 57 data sets i.e., panel voltage, current and duty cycle are

generated for the condition from open circuit to short circuit [13]. The ANFIS model data is shown in the Table 2. Figure 7. Shows the training and checking data correlation curve.

Table 2. ANFIS model data

SL.NO.	PARAMETER	VALUE
1	Number of nodes	131
2	Number of linear parameters	49
3	Number of nonlinear parameters	42
4	Total number of parameters	91
5	Number of training data pairs:	1000
6	Number of checking data pairs	0
7	Number of fuzzy rules	49

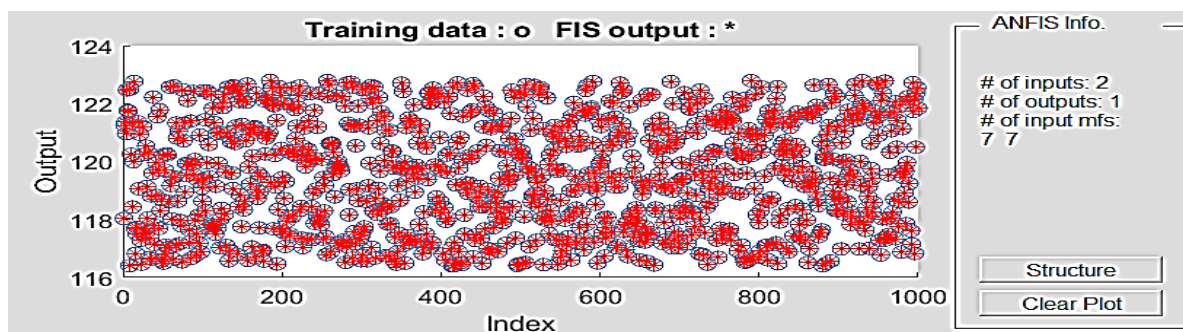
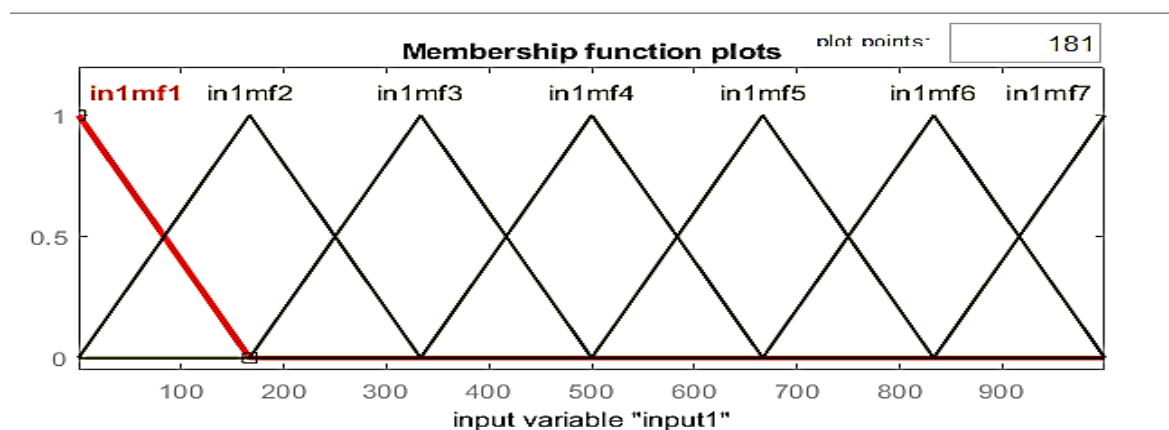

Figure 7. Training and checking data plot

Step 2: Configuration of Fuzzy System for Training

Seven numbers of triangular membership functions are chosen for input and output control parameters. The plotted membership functions of 2' numbers of input such as V_{pv} and I_{pv} are shown in Figures 8(a). and 8(b). respectively.



(a)

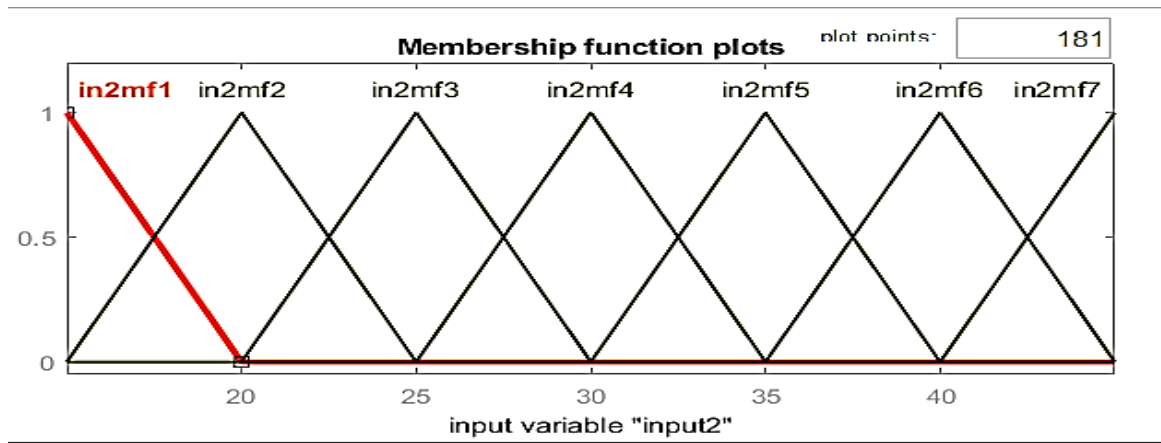

(b)

Figure 8.Membership functions Inputs (a) & (b)

Step 3: ANFIS-Training

ANFIS training is done for 100 epochs; rule viewer is shown in Figure 9. The 49 rules are shown in Fig. 11. The ANFIS generated surface's shown in Fig. 10. Which is a 3D plot between PV voltage PV current and change in duty cycle.

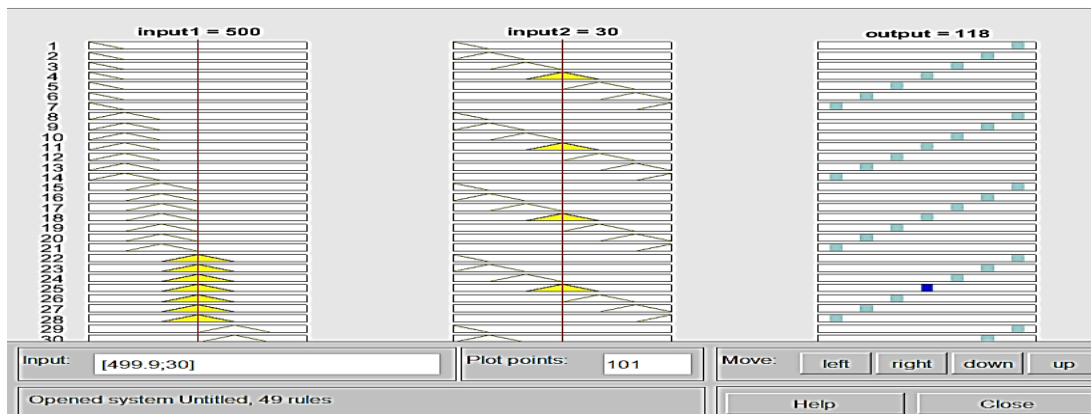

Figure 9. ANFIS MPPT rule viewer

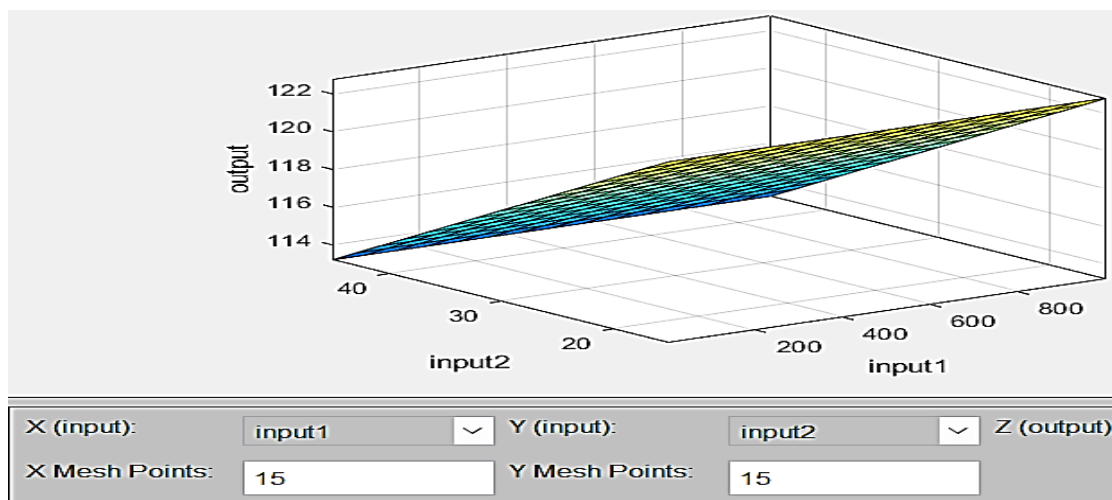

Figure 10. ANFIS MPPT surface viewer

Step 4: Checking data command (chkdata) through MATLAB is used to prevent MPPT model form over fitting during training. Figure 12. shows the training and checking error profile for 100 epochs. The result of the training is as follows: trnRMSE = 0.00104; chkRMSE = 0.075.

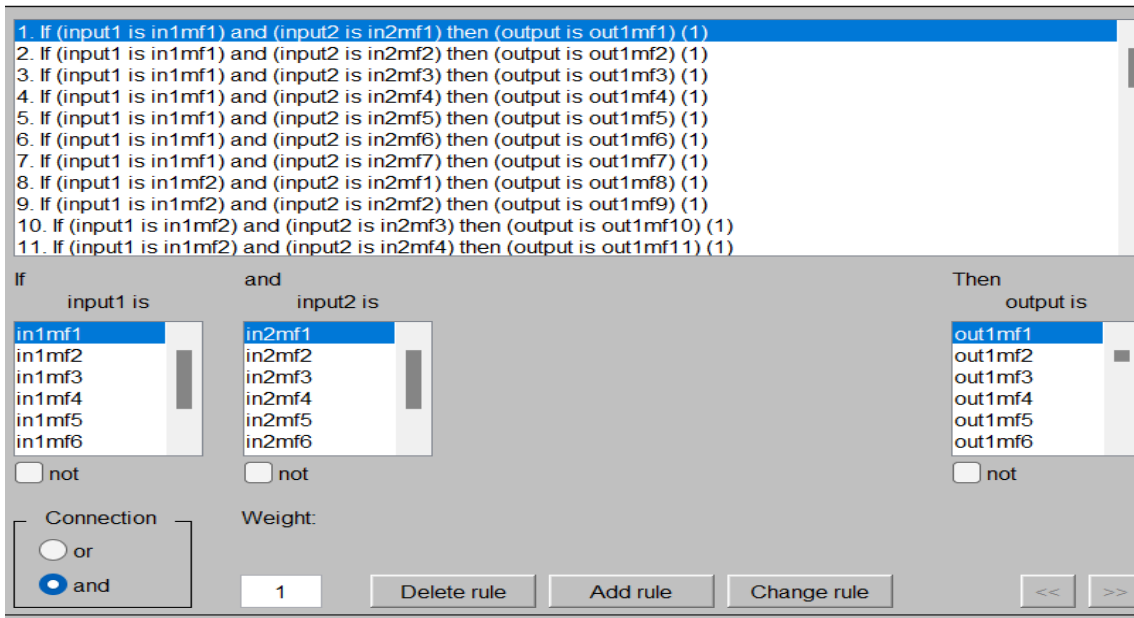

Figure 11. ANFIS MPPT rules

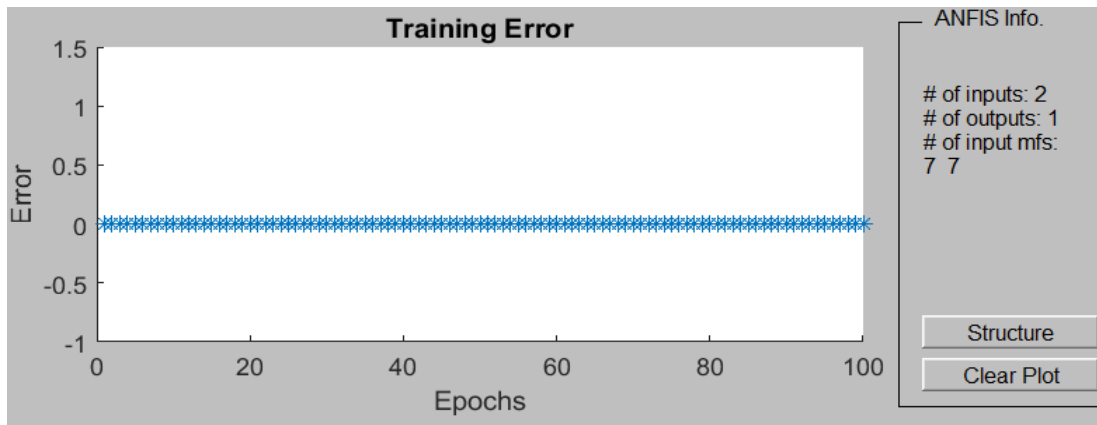

Figure 12. Epoch Vs training error 'o', check error 'x'

The proposed 1KW PV system is performed with three different MPPT techniques namely, Perturb and Observe method, Incremental conductance Method and Artificial neuro fuzzy inference system. The performance of each MPPT controller is separately observed as shown in figure 13.

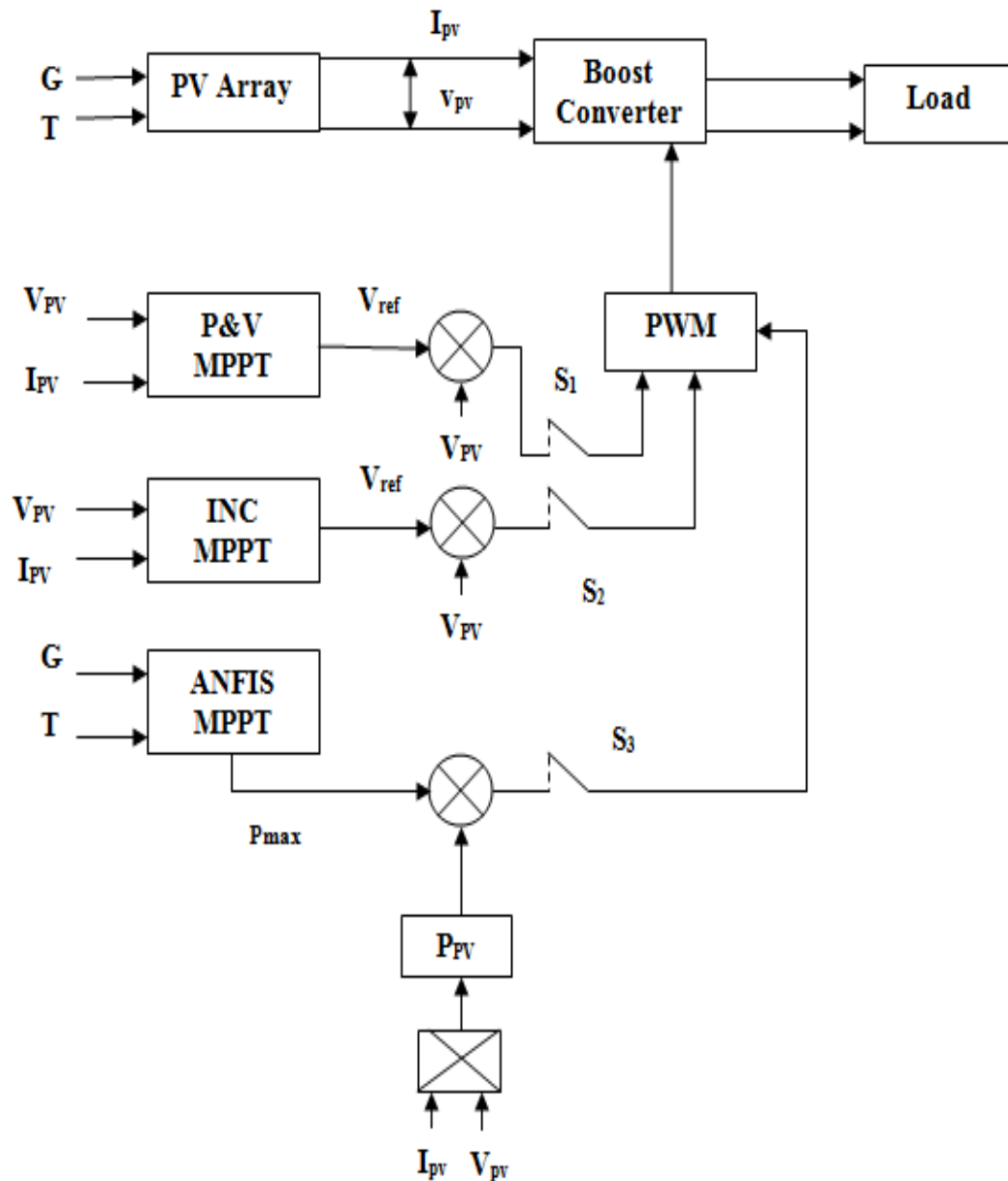

Figure 13. Block diagram of proposed PV system

III. RESULTS AND DISCUSSIONS

Figure 14. shows the I-V and P-V output characteristics of 1KW PV system with different temperature (15°C, 25°C and 45°C) at standard irradiances (1000W/M²). The Maximum voltage is 119.6V, Maximum current is 8.35A and Maximum Power is 1KW are observed. Figure 15. shows the I-V and P-V characteristics of 1KW PV system with different irradiances (100W/M², 500W/M² and 1000W/M²) at standard temperature (25°C).

As the result, INC method is unstable due to oscillations in output waveforms (reference in figure 16. violet color for INC MPPT) but settles faster than P-&-O and ANFIS methods. P-&-O method is also unstable but less oscillation in output parameters when compared with INC MPPT method (reference in figure 16, green color for P-&-O MPPT). ANFIS MPPT controlled configuration

performs well without any oscillations on output side parameters when compared with hill climbing techniques as shown in figure 16. (red color for ANFIS).

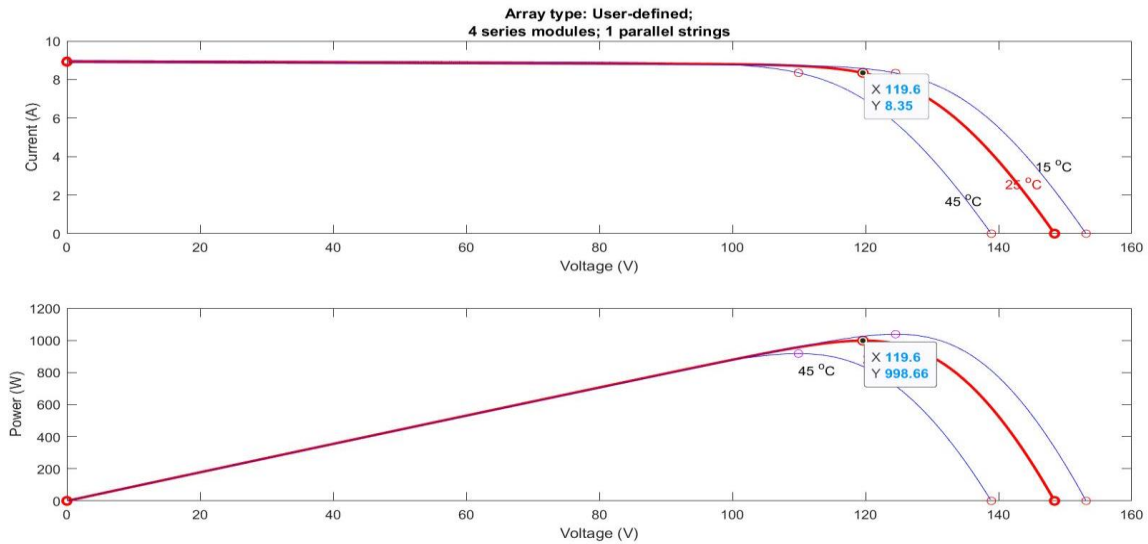

Figure 14. I-V & P-V Characteristics of 1KW PV system for standard irradiances (1KW/M²).

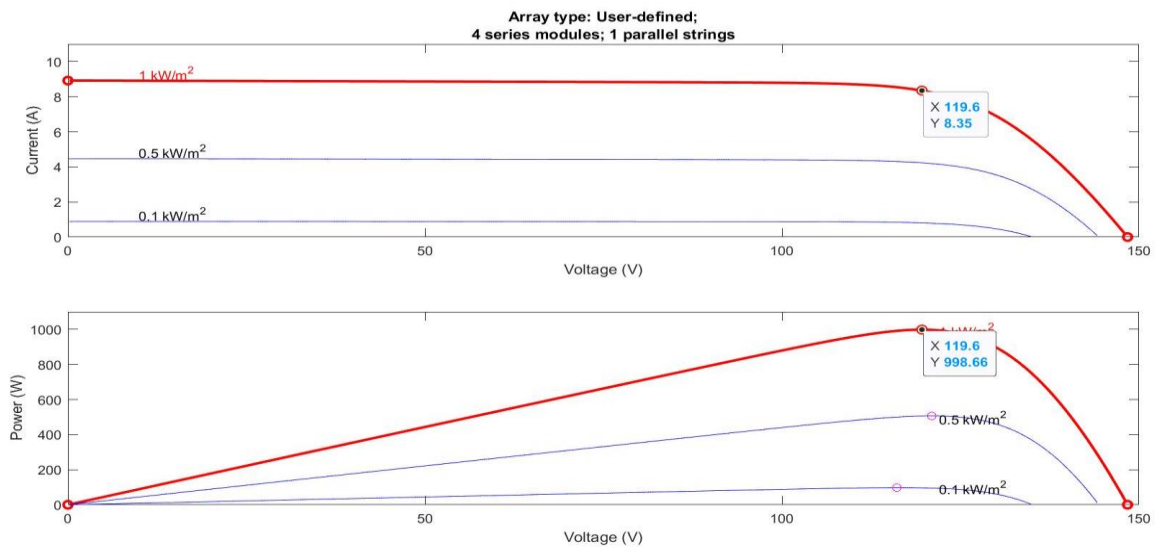

Figure 15. I-V & P-V Characteristics of 1KW PV system for standard temperature (25°C).

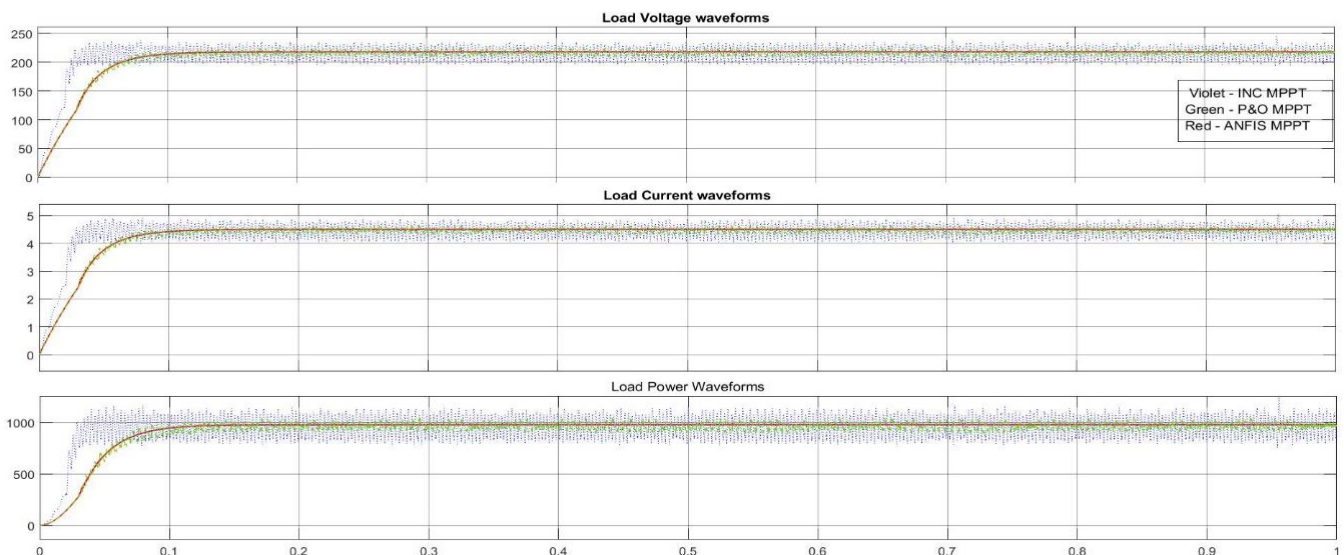

Figure 16. Comparison of Load voltage, current & Power waveforms.

IV. CONCLUSION

The mathematical model of IKW PV system is developed using MATLAB/SIMULINK as presented in section 2, which is used to test its stability and efficiency with different maximum power point tracking controllers. In this paper, the most commonly used MPPT techniques such as Perturb & observe method, Incremental conductance method (Hill climbing methods) and artificial neural based fuzzy inference system (ANFIS) are compared. The duty cycle of DC-to-DC converter is driven by ANFIS MPPT controller which ensures the load power stability and enhanced overall system efficiency. Figure 16 shows the comparative analysis of P-&-O, INC and ANFIS MPPT controller performance on Load voltage, Load current and Load power waveforms. It is very clear that ANFIS controller has proved its excellence and stability on load side by zero ripple in load side parameters. It also extracts maximum power for variable climatic conditions and supplied to load at same quantity as compared with other hill climbing methods as shown in Figure 16. The observations made in this paper are simulated in SIMULINK platform; the physical observation may vary due to hardware selection.

V. ACKNOWLEDGMENT

The authors gratefully acknowledge the support and facilities provided by the authorities of the Annamalai University, Annamalainagar, Tamilnadu and India to carry out this research work.

REFERENCES

- [1] Parag K. Atri, P. S. Modi, Nikhil Shashikant Gujar,2020,"Comparison of Different MPPT Control Strategies for Solar Charge Controller", International Conference on Power Electronics & IoT Applications in Renewable Energy and its Control (PARC,IEEE.vol.1,pp-423-431.
- [2] A.Pradeep Kumar Yadav, S.Thirumaliah, G.Haritha, 2012, "Comparison of MPPT Algorithms for DC-DC Converters Based PV Systems", International Journal of Advanced Research in Electrical, Electronics and Instrumentation Engineering, Vol.pp.18-23.
- [3] Ali RezaReisi , Mohammad Hassan Moradi , ShahriarJamasb,2013, "Classification and comparison of maximum power point tracking techniques for photovoltaic system": A review, Renewable and Sustainable Energy Reviews,vol.19, 433–443.
- [4] Hasan Mahamudul, Mekhilef Saad, and Metselaar, Ibrahim Henk, 2012,"A Modified Simulation Method of Photovoltaic Module in Simulink Environment", International Conference on Electrical and Computer Engineering,IEEE,pp.607-610.
- [5] R.Nagarajan , R.Yuvaraj,2017, "Implementation of PV - Based Boost Converter Using PI Controller with PSO Algorithm", International Journal Of Engineering And Computer Science,vol.6,pp. 20479-20484.
- [6] M. A. Elgendy, B. Zahawi and D. J. Atkinson, 2011, "Evaluation Of Perturb and Observe Mppt Algorithm Implementation Techniques". International Journal of Engineering and Computer Science, vol.6, pp. 20479-20484.
- [7] SAIDI Khadidja, MAAMOUN Mountassar, 2017, "Comparative study of Incremental Conductance and Perturb & Observe MPPT Methods forPhotovoltaic System", IEEE.vol.2, pp-23-0330.
- [8] S.Zahra Mirbagheri , Saad Mekhilef, 2013,"MPPT with Inc.Cond method using conventional interleaved boost converter", Energy Procedia (Science Direct),vol.42,pp.24-32.
- [9] Srushti R. Chafle, Uttam B. Vaidya,2013, "Incremental Conductance MPPT Technique FOR PV System", International Journal of Advanced Research in Electrical, Electronics and Instrumentation Engineering Vol. 2, Issue 6,pp-543-550.
- [10] Dragan Mlakić,2016, MSEE, Full Professor Srete Nikolovski, Anfis as a Method for Determinating MPPT in the Photovoltaic System Simulated in Matlab/Simulink, <https://www.researchgate.net/publication/301788981>, Conference Paper,vol.2,pp-653-660.
- [11] S. R. Revathy, V. Kirubakaran, M. Rajeshwaran, T. Balasundaram, V. S. Chandra Sekar, Saad Alghamdi, Bodour S. Rajab,5 Ahmad O. Babalghith, and Endalkachew Mergia Anbese,2022. "Design and Analysis of ANFIS – Based MPPT Method for Solar Photovoltaic Applications", Hindawi International Journal of Photoenergy Volume vol.12, Article ID 9625564, 9 pages.
- [12] Hasan Mahamudul, Mekhilef Saad, and Metselaar, Ibrahim Henk,2012, "A Modified Simulation Method of Photovoltaic Module in Simulink Environment", 7th International Conference on Electrical and Computer Engineering 20-22, vol.3,pp-11-17,Dhaka, Bangladesh.
- [13] R. K. Kharb, M. F. Ansari, and S. L. Shimi,2014, "Design and implementation of ANFIS based MPPT scheme with open loop boost converter for solar PV module," International Journal of Advanced Research in Electrical, Electronics and Instrumentation Engineering, vol. 3, no. 1, pp. 6517–6524.

