



# CAN based Intelligent Vehicle Collision Avoidance System

1Priyanka M G, 2Vinod B Durdi

<sup>1</sup>Student, <sup>2</sup>Associate Professor

<sup>1</sup>Department of Telecommunication engineering

<sup>1</sup>Dayananda Sagar College of Engineering, Bangalore, India

**Abstract:** Transportation is very important in our daily lives and its development has greatly facilitated much of our work. Accidents are considered one of the most devastating phenomena. There are many reasons for traffic accidents, but most accidents are caused by driver carelessness and uncontrolled speed. In this article, we propose an intelligent vehicle collision avoidance and safety system. Designed to reduce accidents, the system uses ultrasonic sensors to detect and display messages to the driver about vehicles approaching other vehicles. It also notifies the driver of any obstacles that are approaching him. GSM Alert is introduced into the system, pressure sensors detect accidents and send alert messages to the driver. One of the leading causes of accidents is drunk driving. This is because not all police officers can check every vehicle to determine if the person has been drinking. Therefore, there is a need for an effective system for screening drunk drivers with an alcohol detector.

**Index Terms - Automobile, GSM, alcohol detector, Collision, pressure sensor**

## I. INTRODUCTION

Travelling is a significant need in human existence, and this is currently shown to be risky. As the number of vehicles on the road increases, the number of accidents is increasing every day. However, the number of deaths and injuries related to these accidents has decreased due to automobile safety laws and new technologies in the automobile industry. Some of these accidents are caused by misjudging the distance to the nearest vehicle. Collision often occurs when vehicles are driving very close to each other and the driver is asleep or is unaware that a car is approaching. The safety of public and private vehicles is currently a major concern, so a variety of technologies are used to prevent the accidents. Traffic accident is a serious threat to populated places. Accidents are primarily due to three main factors: they sleep, overtake, and drink while driving. To overcome this circumstance our proposed system detects the alcohol content inside the vehicle, sends SMS very interval of time whenever an accident or threat is nearing. When an accident occurs in the vehicle, the installed sensor detects it and transmits the location of the vehicle to the relevant institution.

## II. LITERATURE SURVEY

A. Mohammad Ababneh, et al. [1].

In this article, we propose a intelligent vehicle collision avoidance and safety system. This system is designed to detect an impending collision on the and serves to prevent or reduce the severity of the impending collision from the rear or front of the vehicle. The method presented here uses ultrasonic sound sensor technology, which recognizes and displays messages to the driver for vehicles approaching the vehicle. The system measures the distance between two vehicles which travels in same lane and direction. If the object 's trajectory is towards its vehicle and becomes dangerous, the system places a security measure in its own vehicle.

B. Md Sanauallah Chowdhury, et al. [3].

Car accidents are considered one of the most devastating phenomena. Although there are different reasons behind car crashes, most of the accidents are caused by the driver's inattention and 's failure to control the speed. Furthermore, it seems there were problems in reaching the accident site in time due to lack of consciousness. As a solution, the introduction of Internet of Things (IoT) technologies can decrease the accidents. In this article, an intelligent system is described to warn and control the vehicle's speed , also notifying individuals when an accident occurs. This system always monitors the distance between the vehicle and 4,444 obstacles ahead, using the proximity sensor. It will warn the driver to control the speed and slow down when it reaches the critical distance. Whenever an accident occurs for uncertain conditions, a warning email will be sent to responsible person with the vehicle's details.

### III. PROBLEM STATEMENT

In an emergency, it's important to save one life every seconds. The use of vehicles is increased by shares. Accidents due to traffic jams are also increasing by 4,444 cases per day. This delays the arrival of the ambulance to the scene or the arrival of the from the scene to the hospital, causing casualties. Therefore, it should take the victim to the hospital whenever possible. It is advantageous if the investigation time can be minimized by forwarding the report to the investigation department, as every incident must be reported to the investigation department.

### IV. SYSTEM OVERVIEW

In our system, different sensors have been used to avoid accidents. LPC1768 is used which has inbuilt CAN support to increase the speed of communication between different sensors and controller. LCD display is used to display the accident detection, CAN communication and alcohol detection if present in the vehicle. The implementations of CAN in the field of automotive sector. It is developed on CAN protocol platform using the help of existing embedded system of vehicles. Sensors and actuators are used to get the data and controller is used to perform the instructions based on the data received from the sensors. Benefits of implementing this concept are:

- Safety of passengers can be achieved by locking the ignition system of the vehicle if the driver is drunk – Alcohol Detection
- If an accident took place, the data sent from controller to the CAN data line using this information accident alert SMS is sent. GSM module will send a text alert to relatives of the passengers and concerned authorities.

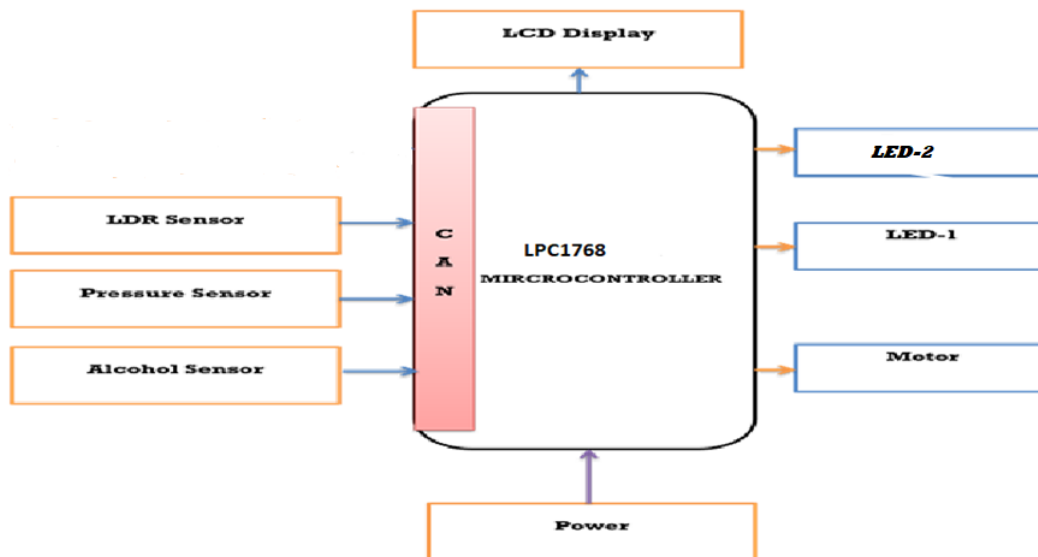

### V. EXPERIMENTAL RESULTS

1. Alcohol sensor: The sensor detects the alcohol inside the vehicle in air. If the alcohol present in air crosses the threshold value, then the alcohol is detected and displayed in the LCD (Fig 1). The engine of the vehicle stops detecting a red LED glow in the system and SMS ( Fig 2) is sent to the respective person/authority.



Fig 1: Alcohol detection in the system

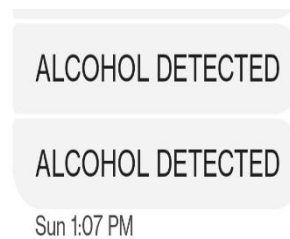

Fig 2: SMS alert for alcohol detection

2. Pressure sensor: When there is pressure applied on the vehicle, the system it detects it as accident and immediately the engine of the vehicle stops and displayed in LCD (Fig 3). The engine stops and red LED glow is detected in the system and SMS (Fig 4) is sent to concerned person.



Fig 3: Accident displayed in LCD

ACCIDENT LOCATION:<http://www.google.com/maps/?q=12.909314780223378,77.56666506506677>

Fig 4: SMS alert with location

## CONCLUSION

The results of the project mainly have three applications. One is designed to prevent and control the vehicle from emergencies caused by obstacle approaching the vehicle, the second is to detect a drunk driver using an alcohol sensor that prevents the driver from starting the vehicle. The third is pressure sensor where the accidents are detected and sends the location via SMS to respective authority and uses a microcontroller to display information on the LCD.

## REFERENCES

- [1] [www.google.com](http://www.google.com)
- [2] Mubashir Murshed, Md Sanallah Chowdhury (2019) ICATIS. "IoT-based Car Accident Prevention and Detection System with Smart Brake Control".
- [3] Adnan M. Al-Smadi, Wasan Al-Ksasbeh, Mohammad Ababneh, Manar Al-Nsairat (IEEE, 2020). "Intelligent Automobile Collision Avoidance and Safety System".
- [4] "Road Traffic Injuries", World Health Organization (WHO), [Online], Available : <https://www.who.int/news-room/fact-sheets/detail/roadtraffic-injuries>
- [5] "How manual gearboxes work", [www.howcarswork.com](http://www.howcarswork.com), [Online] Available : <https://www.howacarworks.com/basics/how-manualgearboxes-work>
- [6] Amitya kumar tripathy, sejal chopra, Samantha Bosco, Srinidhi Shetty, Firdos Sayyad,"Travolution-An Embedded System in passenger car for road safety",ICTSD2015, Feb 04-06-2015, Mumbai, India
- [7] "Accident Prevention using eye-blinking and head movement", ETCSIT (2012) IJCA
- [8] [https://en.wikipedia.org/wiki/List\\_of\\_countrcou\\_by\\_traffic-related\\_death\\_rate](https://en.wikipedia.org/wiki/List_of_countrcou_by_traffic-related_death_rate)
- [9] Smart Vehicle Monitoring by Accident Detection and Prevention System, N.Shankar, B.Indurani, International Journals of Innovative Technology and Exploring Engineering (IJITEE), 2018.
- [10] Ruikar M. "National Statistics of Road Traffic Accidents in India" J orthoptraumatol rehabl 2013