



# INTERNATIONAL JOURNAL OF CREATIVE RESEARCH THOUGHTS (IJCRT)

An International Open Access, Peer-reviewed, Refereed Journal

## IoT Based Real-Time Health Monitoring System Using NIR Spectroscopy

Department of Electronics and Communication Engineering

Poojya Doddappa Appa College of Engineering, Kalaburagi

**Authors:** [Sangappa, Susheel Reddy, Sushil Kumar, Umesh Belle]<sup>1</sup>, [Prof. Pratik Shankar]<sup>2</sup>

### ABSTARCT:

The main focus of the method is to implement a prototype model for the real time patient monitoring system. The proposed method is used to measure the physical parameters like body temperature, heart beat rate, Blood Glucose level and Blood pressure monitoring with the help of biosensors. Conventionally there are number of techniques available for the ICU patient's health monitoring system with wired communication technology. In the novel system the patient health is continuously monitored and the acquired data is transmitted to a using Wi-Fi wireless sensor network. Embedded processor supports for analyzing the input from the patient and the results of all the parameters are stored in the database. If any abnormality felt by the patient indications will send to the medical officials or to the Care taker. The implementation of the system is achieved by the advanced ARDUINO microcontroller and simulation results are obtained.

Now a day's health monitoring is essential for all human beings. In recent years several techniques are used for health monitoring purpose. Here we proposed a Wi-Fi based wireless sensor network for monitoring purpose. Because, it has both data acquisition and data transmission principle. Each of us requires a periodic monitoring of vital parameters and correct treatments based on this data. These processes become even more crucial when people reach a certain age and are not capable to follow their health condition properly without a special medical personnel or sophisticated equipment to perform the monitoring. Therefore, a particular interest is focused on continuous monitoring techniques. For continuous monitoring, Atmega328 microcontroller is used. In this case several sensor units are considered. Namely, Temperature sensor, Heart beat rate sensor. All of sensors are used only for sensing purpose. If the sensed value is equal to normal value, it stops further process. Otherwise, it sends control signals to patient via Actuator.

### 1. INTRODUCAION:

Much architecture for remote health monitoring procedures were developed in the recent years such as smart phone based remote health monitoring application. In remote health care monitoring application, we cannot make use of the available bandwidth successfully, if we use the traditional mode of transmitting the data continuously. It reduces the node life time, even leads to failure of data due to delay and buffer overloading, which is not acceptable particularly in the health care application. The problems that occur due to the improper data association collected from patients have been discussed. The architecture proposed is consists of a central gateway which gathers the data from all the users and transmit it to the central server periodically, where clinicians can classify the user's health status. Therefore, a particular interest is focused on continuous monitoring techniques. Unlike the spot checking, this type of monitoring is able to providing long term information about the patient, helps to record emergency situations and react effectively to any significant change in person's health conditions in a real time. Health care is an important part of everyday life for all human beings on the planet. Each of us requires a periodic monitoring of imperative parameters and right treatments based on this data. These processes become even more crucial when people attain a certain age and are not able to follow their health condition properly without a special medical recruits or sophisticated equipment to perform the monitoring the older person gets, the wider spectrum of possible diseases and unexpected emergency situations might occur. In order to avoid this, he or she needs to be related to the hospital, observed by medical staff and provided with immediate help if some of the parameters are abnormal.

### 2.LITERATURE SURVEY:

- [1] **S. M. Riazul islam et al** proposes an intelligent collaborative security model to minimize security risk; discusses how different innovations such as big data, ambient intelligence, and wearable's can be leveraged in a health care context; addresses various IoT and health policies and regulations across the world to determine how they can facilitate economies and

societies in terms of sustainable development; and provides some avenues for future research on IoT-based health care based on a set of open issues and challenges

- [2] **Junaid Mohammed et al** monitors patient's ECG wave anywhere in the world using IOIO- OTG Microcontroller. Android application is created for ECG Monitoring. IOIO-OTG microcontroller is connected to android phone using USB cable (or) Bluetooth dongle. After collecting data, the wave is sent to android application. Monitor and store ECG waves in that android-based application.
- [3] **Mohammed S. Jasses et al** focused-on body temperature monitoring using Raspberry pi board in cloud-based system. In that paper, Raspberry pi is monitor body temperature and then these parameters are transfer by wireless sensor networks (WSN). Then these data are added to the cloud-based websites. Using this website monitor body temperature.
- [4] **Hasmah Mansor et al** monitor body temperature using LM35 temperature sensor. The LM35 temperature sensor is connected to the Arduino uno board. After that creating a website in SQL database format. Arduino uno board is connected to that website. Then sensor output is sent to the website. Using this website anybody can monitor body temperature in login process.
- [5] **Afef Mdhaffar et al** present a new IoT-based health monitoring approach in which collected medical sensor data is sent to an analysis module via low-cost, low-power and secure communication links provided by a Lora WAN network infrastructure
- [6] **Mathan Kumar et al** discussed about monitors ECG, Respiration rate, heart rate and body temperature. These sensors are connected to PIC16F887A microcontroller. After collecting data from sensors, the data is uploaded to the website manually for monitoring purpose created an android application and webpage for monitoring the health status.
- [7] **Soumya Roy et al** monitor ECG waves of patients. AT Mega 16L microcontroller is used for monitoring ECG waves. Zigbee module is used for transferring ECG waves. Zigbee module is sends data to nearest connected system for ZigBee.

### 3. PROPOSED METHODOLOGY:

BLOCK DIAGRAM:

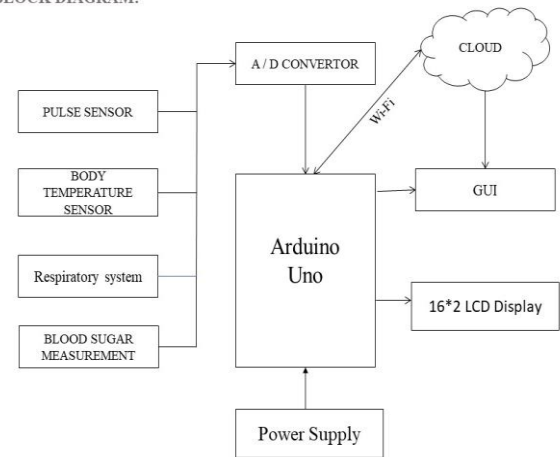

#### Arduino UNO:

The Arduino Uno is a microcontroller board based on the ATmega328 (datasheet). It has 14 digital input/output pins (of which 6 can be used as PWM outputs), 6 analog inputs, a 16 MHz ceramic resonator, a USB connection, a power jack, an ICSP header, and a reset button. It contains everything needed to support the microcontroller; simply connect it to a computer with a USB cable or power it with AC-to-DC adapter or battery to get started.

#### 16\*2 LCD DISPLAY:

Liquid crystal display (LCD) has material which joins together the properties of both liquid and crystals. They have a temperature range within which the particles are essentially as mobile as they might be in a liquid, however are gathered together in an order form similar to a crystal.

The LCD is much more informative output device than a single LED. The LCD is a display that can easily show characters on its screen. They have a couple of lines to large displays. Some LCDs are specially designed for specific applications to display graphic images. 16x2 LCD (HD44780) module is commonly used. These modules are replacing 7-segments and other multi-segment LEDs. LCD can be easily interfaced with microcontroller to display a message or status of the device. It can be operated in two modes: 4-bit mode and 8-bit mode. This LCD has two registers namely command register and data register. It is having three selection lines and 8 data lines. By connecting the three selection lines and data lines with the microcontroller, the messages can be displayed on LCD.

#### HEART RATE SENSOR:

Heart beat sensor is designed to give digital output of heart beat when a finger is placed inside it. This digital output can be connected to Arduino directly to measure the Beats per Minute (BPM) rate. It works on the principle of light modulation by blood flow through finger each pulse. IC LM358 is used for this sensor. Its dual low power operational amplifier consists of a super bright red LED and

light detector. One will act as amplifiers and another will be used as comparator. LED needs to be super bright as the light must pass through finger and detected at another end. When heart pumps a pulse of blood through blood vessels, finger becomes slightly opaquer so less light reach at the detector. With each heart pulse, the detector signal varies which is converted to electrical pulse.

#### TEMPERATURE SENSOR:

The core functionality of the DS18S20 is its direct-to-digital temperature sensor. The temperature sensor output has 9-bit resolution, which corresponds to 0.5°C steps. The DS18S20 powers-up in a low-power idle state; to initiate a temperature measurement and A-to-D conversion, the master must issue a Convert T [44h] command. Following the conversion, the resulting thermal data is stored in the 2-byte temperature register in the scratch-pad memory and the DS18S20 returns to its idle state. If the DS18S20 is powered by an external supply, the master can issue “read-time slots” (see the 1-Wire Bus System section) after the Convert T command and the DS18S20 will respond by transmitting 0 while the temperature conversion is in progress and 1 when the con-ersion is done. If the DS18S20 is powered with parasite power, this notification technique cannot be used since the bus must be pulled high by a strong pull up during the entire temperature conversion. The bus requirements for parasite power are explained in detail in the Powering the DS18S20 section.

VCC pin supplies power for the sensor. It is recommended to power the sensor with between 3.3V to 5V. Please note that the analog output will vary depending on what voltage is provided for the sensor.

GND is a ground connection.

#### RESPIRATORY SENSOR:

The sensor works based on light intensity losses difference obtained due to thorax movement during respiration. The output of the sensor launched to support electronic circuits to be processed in Arduino Uno microcontroller such that the real-time respiratory rate (breath per minute) can be presented on LCD.

#### SOFTWARE REQUIREMENT:

**Blynk App:** allows to you create amazing interfaces for your projects using various widgets we provide.

Blynk was designed for the Internet of Things. It can control hardware remotely, it can display sensor data, and it can store data, visualize it and do many other cool things.

There are three major components in the platform:

**Blynk Server:** responsible for all the communications between the smartphone and hardware. You can use our Blynk Cloud or run your private Blynk server locally. It's open-source, could easily handle thousands of devices and can even be launched on a Raspberry Pi.

#### 4.RESULTS:

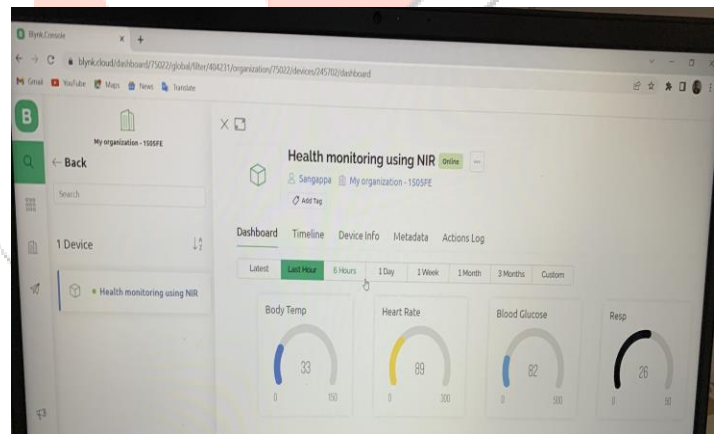
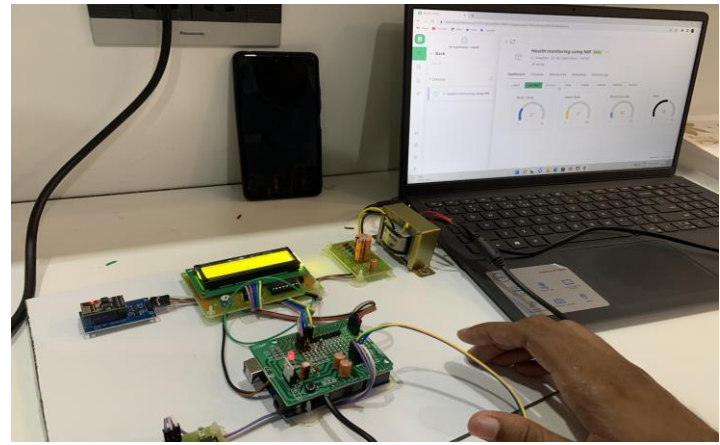

The Above Figure shows the results of this project.

#### 5.CONCLUSION:

In this paper, we proposed a Wi-Fi based remote health monitoring and control system using atmega328 microcontroller, which is capable to continuously monitor the patient's heart beat, blood pressure and other critical parameters in the hospital. We also proposed a continuous monitoring and control mechanism to monitor the patient condition and store the patient statistics in server. For the performance valuation, simulation results are taken by using PROTEUS 7 simulation tool.

**6. REFERENCE:**

- [1] S. M. Riazul islam, Daehan kwak, MD. Humaun Kabir, Mahmud Hossain, and Kyung-sup kwak,” The Internet of Things for Health Care: A Comprehensive Survey”, DOI 10.1109/TDSC.2015.2406699, IEEE Transactions.
- [2] Junaid Mohammed, Abhinav Thakral, Adrian Filip Ocneanu, Colin Jones, Chung-Horng Lung, Andy Adler,” Internet of Things: Remote Patient Monitoring Using Web Services and Cloud Computing”, 2014 IEEE International Conference on Internet of Things (iThings 2014), Green Computing and Communications (GreenCom2014), and CyberPhysical- pp 256-263, 2014
- [3] Mohammad S. Jassas, Abdullah A. Qasem, Qusay H. Mahmoud,” A Smart System Connecting e-Health Sensors and the Cloud a Smart System Connecting eHealth Sensors and the Cloud” Proceeding of the IEEE 28th Canadian Conference on Electrical and Computer Engineering Halifax, Canada, pp 712-716, May 3-6, 2015.
- [4] Hasmah Mansor, Muhammad Helmy Abdul Shukor, Siti Sarah Meskam, Nur Quraisyia Aqilah Mohd Rusli, Nasiha Sakinah Zamery,” Body Temperature Measurement for Remote Health Monitoring System” IEEE International Conference on Smart Instrumentation, Measurement and Applications (ICSIMA)26-27 November 2013.
- [5] Afef Mdhaffar, Tarak Chaari, Kaouthar Larbi, Mohamed Jmaiel and Bernd Freisleben “IoT-based Health Monitoring via Lora WAN”, IEEE EUROCON 2017.
- [6] K. Mathan Kumar, R.S. Venkatesan,” A Design Approach to Smart Health Monitoring Using Android Mobile Devices” IEEE International Conference on Advanced Communication Control and Computing Technologies (ICACCCT), pp 1740-1744,2014.

