



INTERNATIONAL JOURNAL OF CREATIVE RESEARCH THOUGHTS (IJCRT)

An International Open Access, Peer-reviewed, Refereed Journal

SELF-DRIVING CAR USING AI

¹Aakash Makwana , ²Prathamesh Patkar, ³Harsh Amin , ⁴Chinmay Nandoskar , ⁵Prof. Shripad Kulkarni

¹ Student , ² Student, ³ Student , ⁴ Student , ⁵ Professor

Electronics and Telecommunications Department

MCT's Rajiv Gandhi Institute of Technology, Mumbai, India.

Abstract: This paper is intended to represent a mini version of a Self-driving car with IoT and AI using Raspberry Pi and Arduino UNO. The high-resolution 8-megapixel Pi camera provides the necessary information. Raspberry Pi analyses and acquires data samples and will train in Pi using neural networks and machine learning algorithms that lead to lane and traffic detection, lanes and traffic lights and cars alternate accordingly. In addition to these properties the car will be overtaking with the appropriate LED indications on coming across any obstacles.

Keywords :

OpenCV = Open Computer Vision

ML = Machine Learning

AI = Artificial Intelligence

IoT = Internet of Things

1.0 INTRODUCTION

In recent years, autonomous cars have been a prominent focus of automotive engineering research. Designing dynamic route tracking as a crucial component of the control system is one of the most difficult technological difficulties facing autonomous vehicles. Every year, the number of serious traffic accidents rises, from 347 in 2020 to 389 in 2021. There is a pressing need to automate the automobile sector. However, because a vehicle's steering wheel direction varies as it drives in real-time, control methods for autonomous cars that are based on steering angle result in erroneous tracking with regard to a location on the planned track. An autonomous vehicle is defined as a vehicle with advanced characteristics that enable it to steer, brake, and accelerate on its own. Semiautonomous and fully autonomous cars are the two primary categories of autonomous vehicles. Semi-autonomous vehicles can accelerate, brake, and turn, maintain a safe distance from the car in front, and maintain lane integrity at speeds up to 130 km/h, but a driver is still necessary and retains complete control. A completely autonomous vehicle can drive from one location to another without the assistance of a human driver. Recent research has recommended that intelligent transportation systems, variable smarter suspensions, steering systems, torque distribution, steering by wire, and vehicle dynamic modelling improvement be used to develop safer and smarter automobiles. Various research on societal implications, legislation, human-machine interactions, and autonomous implementation techniques have been done. The goal of a semi-autonomous vehicle is for an algorithm to detect or learn various parts of a car, such as wheels or other car components, objects/people traveling/present around the driverless car, and as it is exposed to more inputs, connections to the eventual outputs and actions to be triggered in the car in response begin to develop.

2.0 LITERATURE SURVEY

1. The research article "Working Models for Self-Driving Cars with Convolutional Neural Networks, Raspberry Pi, and Arduino" by Aditya Kumar Jain. The proposed approach uses a camera mounted on a raspberry pi in the car to capture the image. The Raspberry Pi is connected to the same network as the laptop, and the Raspberry Pi delivers the captured image to a convolutional neural network. The image is converted to grayscale before it is sent to the neural network. The model predicts one of four possible outcomes: left, right, forward, or stop. When the result is predicted, the Arduino signal will be activated and the car will be able to drive in a particular direction using the controller.
2. The research paper "Self Driving Cars: A Peep into the Future" presented by T. Banerjee, S. Bose, A. Chakraborty, T. Samadder Bhaskar Kumar, T.K. Rana. This research paper describes the design of embedded controller for self-driving, electric, impact-resistant, and directional GSM vehicles. The vehicle's position, starting point, and destination are properly tracked by the GPS module and the coordinates are mapped to allow navigation. When the vehicle is visible from the front, the speed of the vehicle is automatically adjusted by maintaining a safe distance, which is a function of speed. A stepper motor-driven rotational

distance measuring sensor continuously monitors the distance between the vehicle in front and the vehicle on the side and adjusts the speed limit and lane change accordingly.

3. "Self Driving and Driver Relaxing Vehicle" entitled paper published by a Qudsia Memon, Muzamil Ahmed, Shahzeb Ali, Azam Rafique Memon, and Wajiha Shah. In this study, they had created two self-driving car application that allows drivers to rest for a short period of time. It also presents a concept centered around the modified Google car idea, where Google cars need to arrive automatically at static destinations. In this prototype, they created a dynamic target. Here, self-driving cars track vehicles traveling along a given route. This vehicle is followed by this prototype.
4. ChunChe Wang, ShihShinh Huang, LiChen Fu, Pei Yung Hsiao article "Driving Assistance System for Night Vision Lane Recognition and Vehicle Detection". The purpose is to improve driving by developing a support system. This study combines lane detection with vehicle identification technology to improve driver safety at night. It can detect lanes and help locate markers. To extract an edge, use a cenny edge detection operation, followed by the selection of potentials edge points.
5. The paper "A Vision-based Method for Improving Safety of Self Driving" by Dong, D., Li, X., and Sun gives details about a simulator that can recognize traffic signs, lanes, and road segmentation.
6. R.Mohanapriya, L.K. Hema, Dipesh Warkumar Yadav, Vivek KumarVerma's published "GPS-based autonomous vehicles for future public transport". The four-wheeled robot is equipped with a GPS and GSM system. The robot is guided by a GPS system and can move from one place to another without human intervention. In the former case, it promises to report any theft in the GSM system. Vehicle owners can receive SMS notifications notifying them of problems and turn off the ignition. In the latter case, the project was designed that way that the vehicle can only be turned on if an authorized person sent the predefined location to the vehicle.

3.0 PROPOSED APPROACH

A. Block Diagram

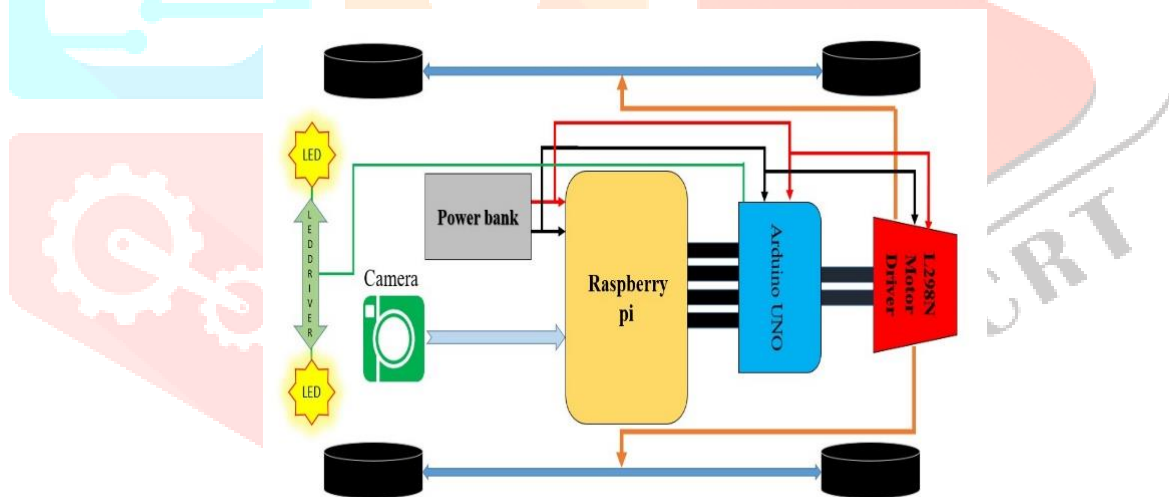

Fig 1 : Block Diagram

B. Our Proposed Method

In our system we have used a pattern matching approach that uses a camera to recognize a unique pattern printed on the road. The camera collects this pattern, processes it using the Raspberry Pi, and then tells the car to go in the desired direction. The camera also collects images of the surroundings to identify various obstacles in the area. If an obstacle gets too close to the vehicle then the vehicle will stop and change the path accordingly. Special patterns and road signs are placed along the route to determine which type of operations need to perform on a vehicle.

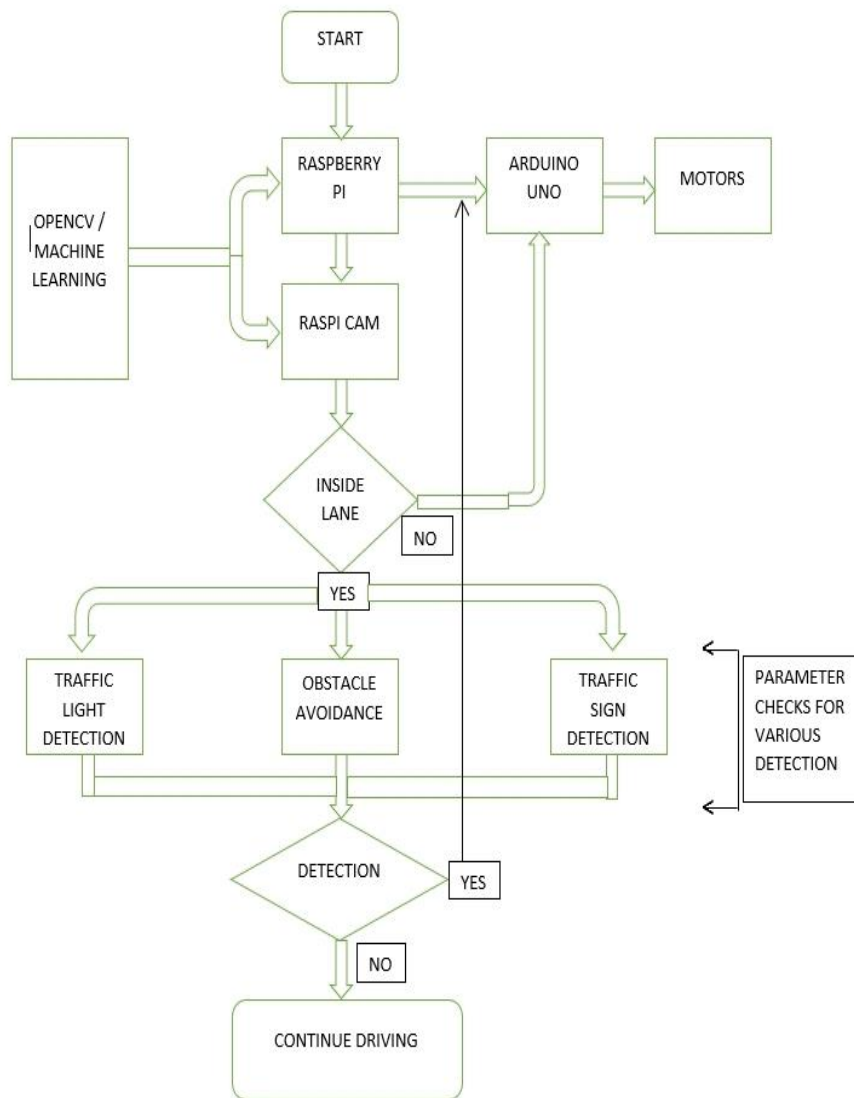

Fig 2 : Flowchart

4.0 RESULT AND DISCUSSION

The project was evaluated and tested. The model can identify the specific pattern and can also detect barriers in the environment, as seen in the preceding photographs. As a result, the model is capable of doing all of the aforementioned tasks.

Detections: In this time span of the project, we experimented with various types of detections on our trained model which makes it work in autonomous mode. These detections are as follows.



Fig 3 : Traffic Light Detection

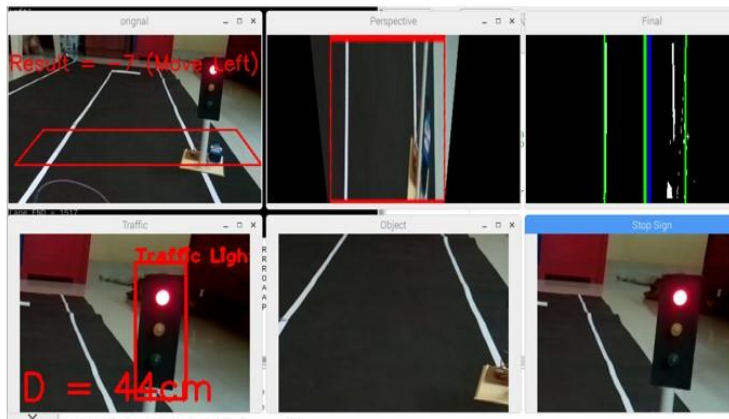

Fig 4 : Traffic Light Detection

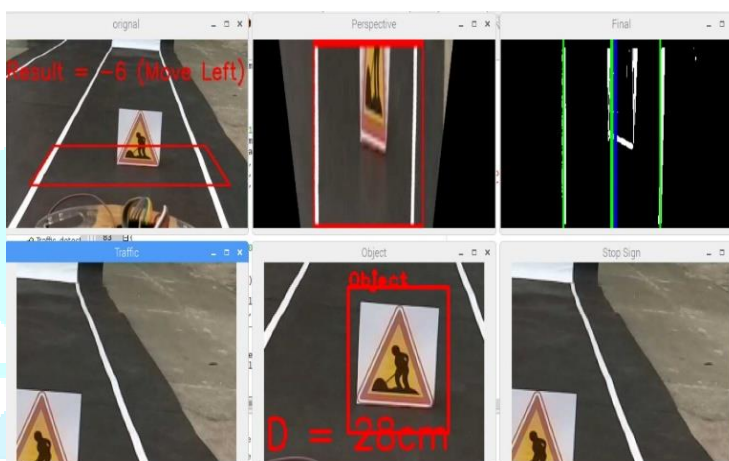

Fig 5 : Obstacle Detection

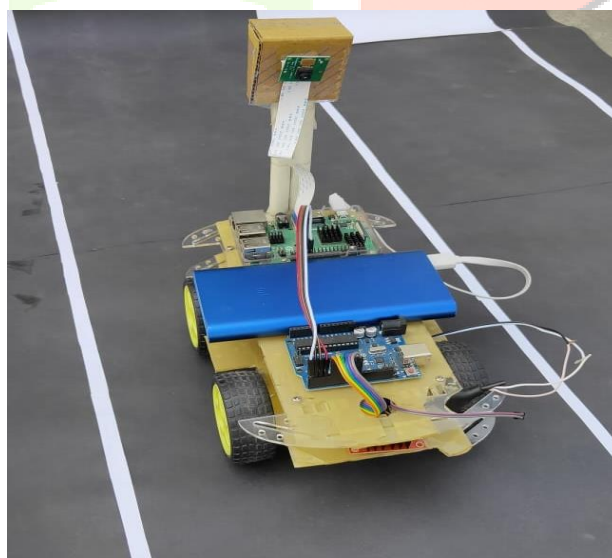

Fig 6 : Lane Detection

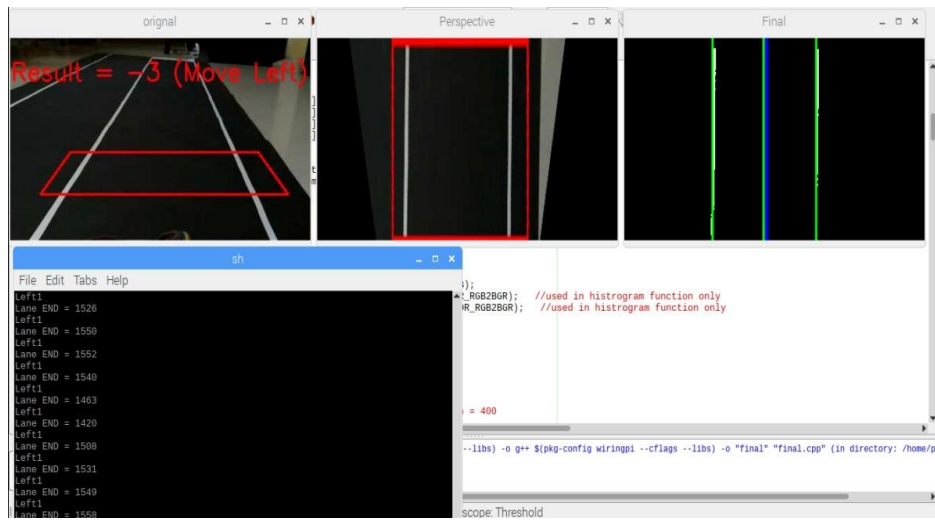

Fig 7 : Lane Detection

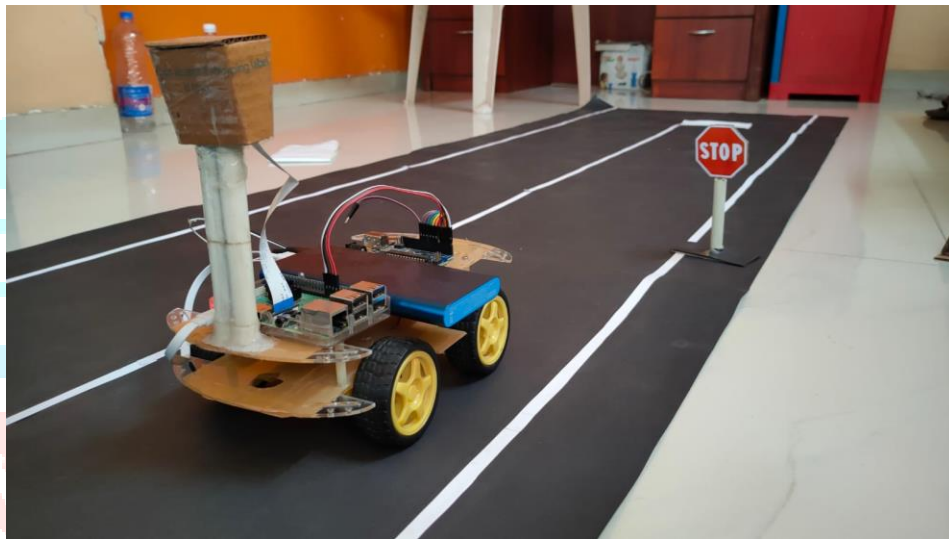

Fig 8 : Stop Sign Detection

5.0 APPLICATION

1. Parking Lots for Self-Driving Cars

Private self-driving cars will park elsewhere without driver intervention. Owners of these cars can send their cars to nearby locations with additional vacant parking spaces.

2. Avoid Accidents

It is estimated that human error accounts for 94% of all accidents. Self-driving cars are much safer because they eliminate the risk of human error, and road accidents can become obsolete. Eliminating road accidents will boost our economy and ease our health care system.

3. Managing Traffic Jam

The root cause of traffic congestion is essentially human-related. The response time of the system is faster than humans with predictive emergency braking, radar technology, cameras and sensors for better traffic management. The need for traffic police can also be reduced.

6.0 CONCLUSION AND FUTURE SCOPE

Self-driving cars are a cost-effective and environmentally friendly means of transportation that can reduce accidents and make commuting more comfortable. Self-driving cars are no longer science fiction novels and will soon become commonplace. We are living in a new era of transportation where human-powered transport vehicles are being replaced by computerized self-driving cars. There are many possibilities for self-driving cars in the future. Some car companies are rapidly developing self-driving cars to make them more accurate and safe. Self-driving cars are a major advance in the automated realm of the future. This project focuses on

making changes in road safety and commuting through continuous learning of the system, and significantly reducing accidents and human error.

7.0 ACKNOWLEDGEMENT

We extend our sincere thanks to Prof. Shripad Kulkarni , Dept of EXTC, Prof. Kishor Sawarkar , Dept of EXTC, Prof. Shashank Gothankar , Dept of EXTC.

8.0 REFERENCES

- [1] A. K. Jain, "Working model of Self-driving car using Convolutional Neural Network, Raspberry Pi and Arduino," 2018 Second International Conference on Electronics, Communication and Aerospace Technology (ICECA), 2018, pp. 1630-1635, doi: 10.1109/ICECA.2018.8474620.
- [2] Raivo Sell, Anton Rassõlkin, Mairo Leier, Juhan-Peep Ernits, "Self-driving car ISEAUTO for research and education" in 19th international conference on Research and Education in Mechatronics (REM), IEEE, 2018, pp: 111-116.
- [3] T. Banerjee, S. Bose, A. Chakraborty, T. Samadder, Bhaskar Kumar, T.K. Rana, "Self Driving Cars: A Peep into the Future", IEEE, 2017, pp: 33-38.
- [4] Qudsia Memon, Muzamil Ahmed and ShahzebAli, "SelfDriving and Driver Relaxing Vehicle", in IEEE 2016, pp: 170-174.
- [5] Mohammad Faisal Bin Ahmed, Md. Saef Ullah Miah, Md. Muneef Anjum Timu, Shakura Akter, Md. Sarker.b, "The Issues and the Possible Solutions for Implementing SelfDriving Cars in Bangladesh" in Regin 10 Humanitarian Technology Conference(R10-HTC), IEEE,2017, pp: 250- 254.
- [6] Margrit Betke, EsinHaritaoglu, Larry S.Davis, "Real-time multiple vehicle detection and tracking from a moving vehicle", in Machine Vision and Application, IEEE, 2000, pp: 69-83
- [7] Raturaj Kulkarni, Shruti Dhavalikar, Sonal Bangar, "Traffic Light Detection and Recognition for SelfDriving Cars using Deep Learning" in 4th International Conference on Computing Communication Control and Automation(ICCUBEA), IEEE, 2018
- [8] Chun-Che Wang, Shih-Shinh Huang and Li-Chen Fu, PeiYung Hsiao "Driver Assistance System for Lane Detection and Vehicle Recognition with Night Vision", IEEE

