



Advanced Ultrasonic Inspection Techniques For Weld Quality Assurance In Ferrous Plate And Piping Butt Joints: A Comprehensive Approach Incorporating TOFD, Phased Array, And Manual UT.

¹Madhur Sharma

¹Master of Candidate, Department of Mechanical Engineering

Career Point University, Kota, Rajasthan. India

Abstract: This paper outlines a meticulous ultrasonic examination procedure for carbon steel and low-temperature carbon steel butt weldments, aligning with ASME guidelines. Employing TOFD as the primary technique supplemented by PAUT and MUT, it emphasizes equipment calibration, defined scanning parameters, and thorough documentation. Analysis of samples showcases effective defect detection and assessment, with adherence to safety protocols and documentation standards. Recommendations include continuous training and procedural updates. In essence, this procedure ensures the integrity of weld joints in ferrous plate and piping applications, aligning with industry standards.

Keywords: Ultrasonic examination, carbon steel, low-temperature carbon steel, weld inspection, Time-Of-Flight Diffraction (TOFD), phased array ultrasonic testing (PAUT), manual ultrasonic testing (MUT), ASME standards, calibration, documentation, weld joints, ferrous plate, piping applications.

1. Introduction

Non-Destructive Testing (NDT) is a critical facet of quality control that enables the evaluation of materials and components without causing any damage. This method ensures the integrity and reliability of structures, machinery, and products throughout various industries. NDT plays a pivotal role in sectors such as aerospace, automotive, oil and gas, and construction.

The significance of NDT lies in its ability to identify defects, irregularities, or weaknesses in materials, preventing potential failures and ensuring safety. In aerospace, NDT ensures the structural integrity of aircraft components, while in the automotive industry, it is employed to examine welds and detect flaws in materials. Moreover, in the oil and gas sector, NDT is crucial for assessing the condition of pipelines and ensuring the safety of operations. In construction, NDT verifies the quality of materials and structural components, contributing to the longevity of buildings.

Technological advancements have marked the evolution of NDT techniques. Traditional methods, such as visual inspection and penetrant testing, have been complemented and surpassed by advanced techniques like ultrasonic testing, radiography, and magnetic particle testing. These innovations have enhanced the accuracy, speed, and scope of NDT, making it an indispensable tool for maintaining the integrity and reliability of diverse materials and structures across industries.

As highlighted by Smith et al. (2020), the evolution of NDT is a dynamic process, driven by the need for more reliable and efficient inspection methods. In conclusion, NDT stands as a cornerstone in ensuring the safety and reliability of structures and components across diverse industries, with a trajectory of continual advancement in its techniques and applications.

2. Phased Array Ultrasonic Testing (PAUT)

Phased Array Ultrasonic Testing (PAUT) is an advanced non-destructive testing (NDT) technique used for inspecting materials and structures by utilizing ultrasonic waves. Unlike conventional ultrasonic testing methods that use a single transducer to emit and receive ultrasound, PAUT employs multiple small elements within a single transducer probe. These elements can be electronically controlled to manipulate the direction and focus of the ultrasonic beam.

The basic principle of PAUT involves the creation of a phased array of ultrasonic waves by adjusting the timing and amplitude of individual transducer elements. This phased array allows for the steering, focusing, and shaping of the ultrasonic beam, providing greater flexibility and precision in detecting flaws and anomalies in a material.

2.1 Purpose in Non-Destructive Testing (NDT):

The primary purpose of Phased Array Ultrasonic Testing is to perform highly efficient and accurate inspections of materials and structures without causing any damage. PAUT is extensively used in various industries such as aerospace, oil and gas, manufacturing, and construction to detect defects like cracks, voids, and other discontinuities. It is particularly beneficial for inspecting complex geometries and materials with anisotropic properties.

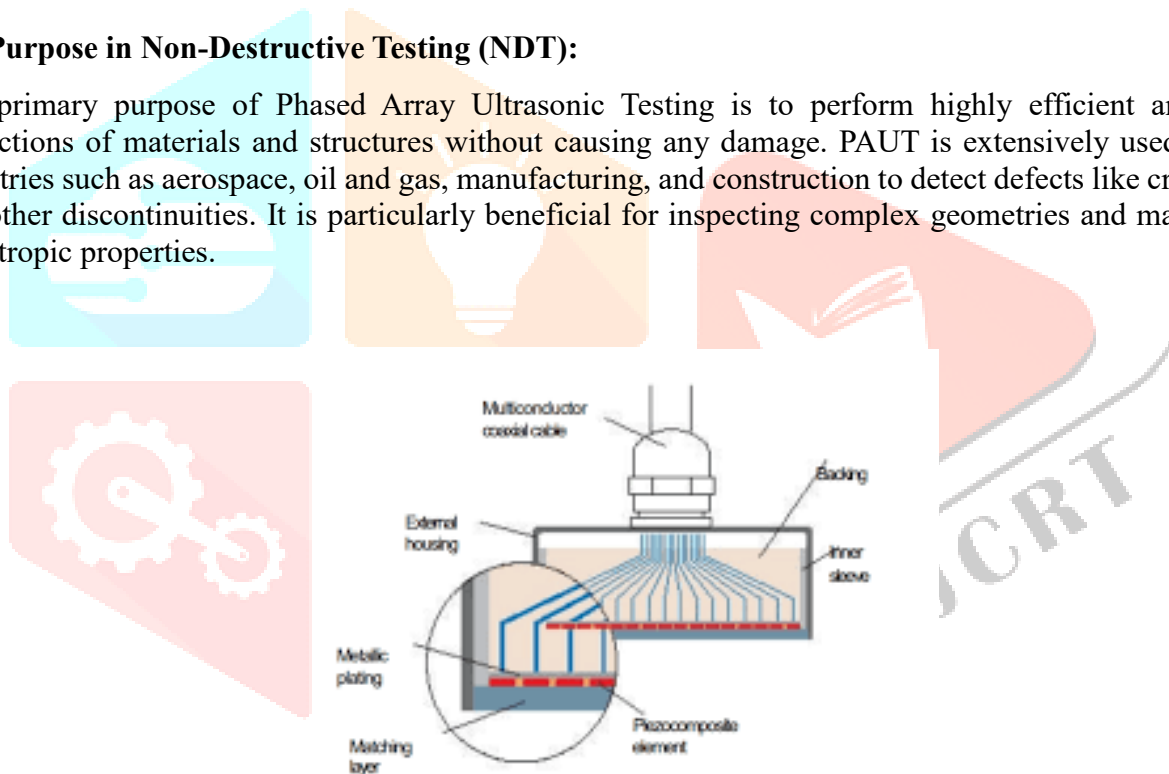

PAUT is commonly employed in weld inspections, corrosion mapping, and thickness measurements. Its ability to electronically control the beam allows for rapid scanning and detailed imaging, enhancing the inspector's capability to identify and characterize flaws in the inspected material.

2.2 Advantages over Conventional Ultrasonic Testing:

Phased Array Ultrasonic Testing offers several advantages over conventional ultrasonic testing methods:

- Increased Inspection Speed:** PAUT allows for faster inspections due to its ability to scan and steer the ultrasonic beam electronically. This reduces inspection time, making it more time-efficient than traditional methods.
- Improved Imaging and Detection Capability:** The electronic control of the phased array enables better focus and resolution, leading to enhanced imaging and flaw detection capabilities. This is especially crucial for identifying small or complex defects.

c. **Adaptability to Complex Geometries:** PAUT is well-suited for inspecting components with complex shapes and geometries. The flexibility to manipulate the ultrasonic beam direction ensures comprehensive coverage, even in challenging inspection scenarios.

d. **Real-Time Data Analysis:** Phased array systems provide real-time data, allowing inspectors to analyze and interpret results on-site. This immediate feedback facilitates prompt decision-making and, if necessary, adjustments to the inspection process.

e. **Reduced Coupling Dependency:** PAUT is less dependent on the coupling medium between the transducer and the material being inspected. This reduces the need for precise coupling and allows inspections through coatings and other challenging surface conditions.

Phased Array Ultrasonic Testing represents a significant advancement in non-destructive testing, offering superior speed, precision, and adaptability compared to conventional ultrasonic testing methods.

3. Time-of-Flight Diffraction (TOFD)

Time-of-Flight Diffraction (TOFD) is an advanced ultrasonic non-destructive testing (NDT) technique used for the detection and sizing of flaws or discontinuities in materials. TOFD relies on the principles of diffraction, where sound waves are directed towards a material, and the echoes and diffracted waves are analyzed for flaw characterization.

In TOFD, a pair of ultrasonic transducers is utilized – one emitting ultrasonic waves, and the other receiving the diffracted signals. The basic principle involves measuring the time taken for ultrasonic waves to travel from the transducer, diffract around the flaw, and reach the receiving transducer. By analyzing the time-of-flight and diffraction patterns, TOFD provides detailed information about the size, location, and orientation of flaws within the material.

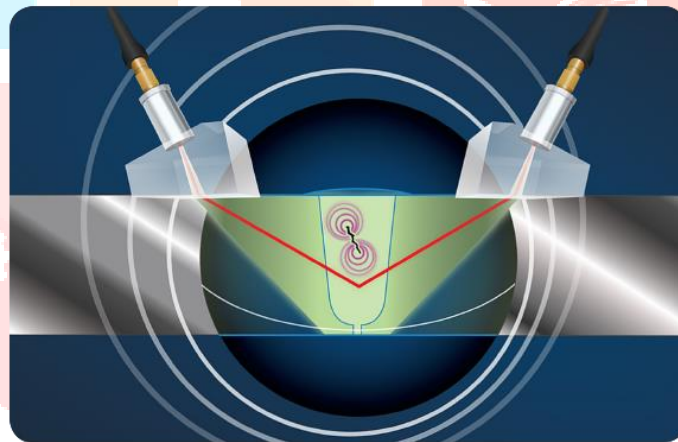

3.1 Purpose in NDT

TOFD plays a crucial role in non-destructive testing by providing high-resolution imaging of flaws in various materials such as welds, pipelines, and structural components. Its primary purposes include:

- **Accurate Flaw Sizing:** TOFD excels in accurately sizing flaws, offering a detailed analysis of the flaw dimensions, including length and height.
- **Efficient Inspection of Welds:** In welding inspections, TOFD is particularly valuable for detecting and characterizing defects like cracks, lack of fusion, or porosity within the weld zone.
- **Enhanced Reliability:** The technique enhances the reliability of flaw detection by providing a comprehensive view of the inspected material, reducing the likelihood of overlooking critical defects.

3.2 Advantages over Traditional Ultrasonic Techniques:

TOFD presents several advantages over traditional ultrasonic techniques, contributing to its widespread adoption in NDT applications:

- **Increased Sensitivity:** TOFD is highly sensitive to both planar and non-planar flaws, offering improved flaw detection capabilities compared to conventional ultrasonic methods.
- **Accurate Sizing:** One of the key advantages is its ability to accurately size and characterize flaws, providing detailed information about the dimensions and orientation of defects.
- **Efficiency in Data Interpretation:** The graphical representation of data obtained through TOFD simplifies the interpretation process, making it easier for inspectors to analyze and assess the integrity of the material.
- **Real-time Imaging:** TOFD produces real-time cross-sectional images of the inspected material, allowing for immediate analysis and decision-making during the inspection process.

These advantages contribute to the growing preference for TOFD in various industries where precise flaw detection and sizing are paramount, such as aerospace, oil and gas, and manufacturing.

Aspect	TOFD (Time-of-Flight Diffraction)	PAUT (Phased Array Ultrasonic Testing)	Traditional Ultrasonic Techniques
Inspection speed	Fast, can cover large areas quickly	Moderate, depending on setup and scanning speed	Slower, requires manual scanning
Defect sizing accuracy	High accuracy in sizing defects	High accuracy in sizing defects	Lower accuracy, especially for complex shapes
Detection of planar defects	Very effective due to diffraction patterns	Very effective due to controlled beam steering	Effective but may miss smaller defects
Coverage of complex geometry	Limited by access requirements	Good, can adapt beam angles for complex shapes	Limited, may require multiple angles
Automation capability	Limited automation due to data interpretation	High automation potential, software-controlled	Limited automation, mostly manual operation
Data storage and analysis	Requires specialized software for analysis	Advanced data storage and analysis capabilities	Limited data storage and analysis options
Operator training and expertise	Moderate training required for interpretation	Moderate to high training for setup and analysis	Extensive training for interpretation
Cost	Moderate cost for equipment and training	Higher initial cost, but potentially lower long-term	Lower initial cost, but higher long-term

4. Comparison of PAUT and TOFD

Both Utilize Ultrasonic Waves:

- **Phased Array Ultrasonic Testing (PAUT):** PAUT employs ultrasonic waves to inspect materials for defects or anomalies. It utilizes multiple ultrasonic elements within a probe to generate and steer beams electronically, allowing for the examination of various angles and focal points. The ability to manipulate the beam direction provides flexibility in detecting flaws from different orientations.
- **Time-of-Flight Diffraction (TOFD):** Similarly, TOFD also relies on ultrasonic waves to assess materials. It involves the transmission of ultrasonic pulses, and the measurement of diffracted waves to identify defects. TOFD typically employs a pair of probes, one for transmitting and the other for receiving signals, contributing to a detailed analysis of the inspected material.

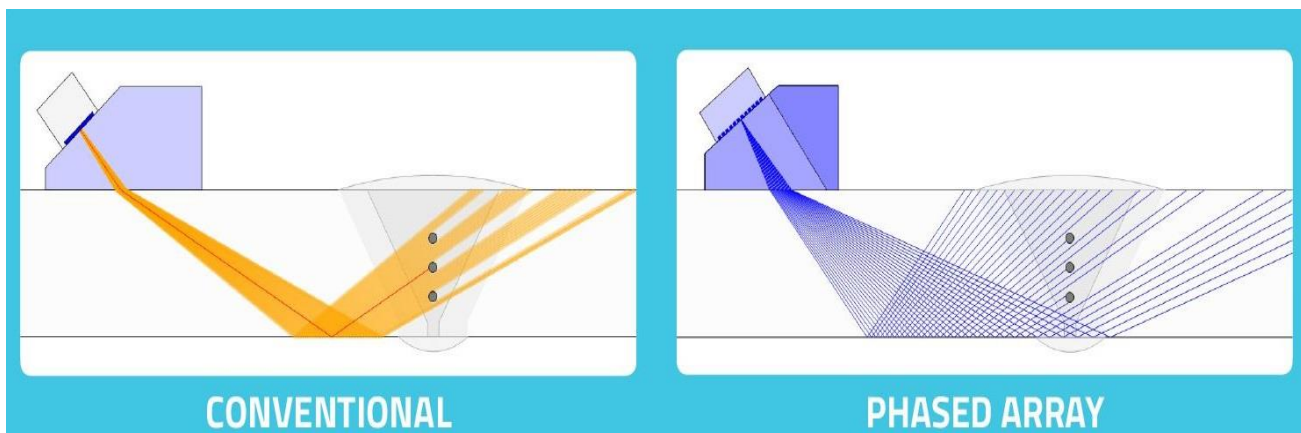

4.1 Non-Destructive Nature

Both PAUT and TOFD fall under the category of non-destructive testing (NDT) techniques. This means that the examination process does not compromise the structural integrity of the tested material. By utilizing ultrasonic waves, these methods allow for comprehensive inspections without causing any damage, making them highly advantageous for quality control and integrity assessment.

4.2 High Sensitivity and Precision

- **Phased Array Ultrasonic Testing (PAUT):** PAUT offers high sensitivity and precision due to its ability to control the ultrasonic beam's focal point and steering. This enables the detection of small defects and provides detailed information about the size, shape, and location of anomalies.
- **Time-of-Flight Diffraction (TOFD):** TOFD is renowned for its accuracy in defect sizing and localization. By analyzing the diffracted waves, TOFD achieves a high level of sensitivity, making it effective in identifying flaws with precision.

Both PAUT and TOFD share commonalities in utilizing ultrasonic waves, maintaining a non-destructive nature, and exhibiting high sensitivity and precision in defect detection.

4.3 Key Differences

Phased Array Ultrasonic Testing (PAUT) and Time-of-Flight Diffraction (TOFD) are advanced non-destructive testing techniques widely used in various industries to detect and evaluate flaws in materials. One key aspect that sets them apart is their scanning mechanism.

4.4 Scanning Mechanism:

a. **Phased Array Scanning (PAUT):** PAUT employs a phased array transducer that consists of multiple elements, each individually controlled to produce a focused and steerable ultrasonic beam. This enables the technician to electronically adjust the beam angle, focus, and depth in real time during the inspection process. The ability to manipulate the beam electronically enhances the inspection's flexibility and efficiency, making it particularly effective for complex geometries and varying material properties.

b. **Diffraction-based Scanning (TOFD):** TOFD, on the other hand, relies on the diffraction phenomenon for flaw detection. It involves sending ultrasonic waves through the material at a fixed angle, and the diffracted waves resulting from the edges of a discontinuity are detected. TOFD utilizes two probes – one for emitting the ultrasonic wave, and the other for receiving diffracted signals. The time of flight of diffracted signals is analyzed to determine the size and location of defects. TOFD is known for its high sensitivity in detecting small cracks and sizing capabilities.

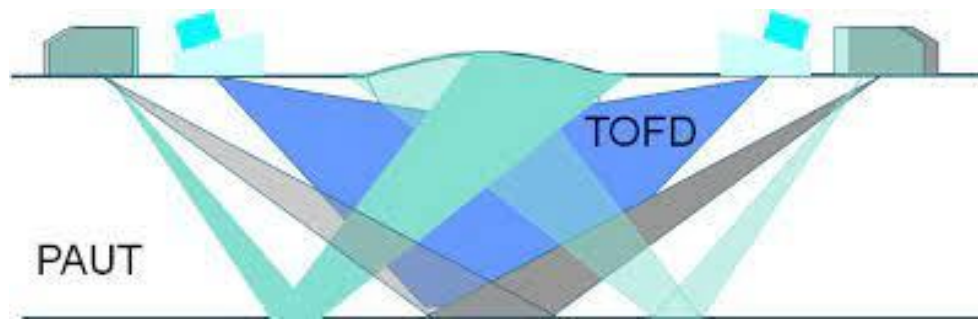

These scanning mechanisms highlight the fundamental difference between PAUT and TOFD. PAUT offers dynamic control over the inspection parameters, making it versatile for a wide range of applications, while TOFD relies on the analysis of diffracted signals for precise flaw detection and sizing.

It's important to note that the choice between PAUT and TOFD depends on the specific requirements of the inspection, such as the type of material, geometry, and the size of flaws expected. In some cases, a combination of both techniques may be employed to leverage their respective strengths and enhance the overall inspection reliability.

While PAUT and TOFD serve the common purpose of non-destructive testing, their scanning mechanisms set them apart, with PAUT utilizing phased array transducers for electronic beam control and TOFD relying on the diffraction of ultrasonic waves for flaw detection.

4.5 Imaging Capabilities:

Ultrasonic testing methods, such as Phased Array Ultrasonic Testing (PAUT) and Time-of-Flight Diffraction (TOFD), play crucial roles in non-destructive testing (NDT) for flaw detection and characterization. These techniques differ in various aspects, including imaging capabilities, applications, and limitations.

a. Real-time Imaging in PAUT vs. Diffraction Imaging in TOFD

- **Phased Array Ultrasonic Testing (PAUT):** PAUT employs multiple ultrasonic elements that can be individually controlled, allowing for real-time beam steering and focusing. This dynamic control enables the creation of detailed cross-sectional images of the inspected material. The phased array transducer configuration in PAUT offers the advantage of electronic scanning, enabling the inspector to visualize flaws from different angles in real time.
- **Time-of-Flight Diffraction (TOFD):** TOFD relies on diffraction phenomena for flaw detection. It involves sending ultrasonic waves at a fixed angle, and the diffracted waves from the flaw tips are used to determine the flaw's position and size. Unlike PAUT, TOFD produces a diffraction image that represents the diffracted energy, providing information about the flaw's geometry and dimensions. However, TOFD does not offer real-time imaging capabilities as the data is typically collected and analyzed after the inspection.

4.6 Applications and Limitations

a. Specific Industries or Components Where Each Excels

- **Phased Array Ultrasonic Testing (PAUT):**
 - **Aerospace Industry:** PAUT is widely used in the aerospace sector for inspecting critical components such as turbine blades and composite materials due to its ability to provide detailed real-time images.
 - **Weld Inspection:** PAUT excels in weld inspection applications, offering precise flaw detection and sizing in welds of various geometries.
 - **Corrosion Mapping:** PAUT is effective for corrosion mapping in pipelines and other structures, providing accurate thickness measurements and flaw detection.

- **Time-of-Flight Diffraction (TOFD):**
 - **Pipe Welds:** TOFD is particularly suited for the inspection of pipe welds, where it excels in detecting and sizing planar flaws such as cracks and lack of fusion.
 - **Nuclear Industry:** In the nuclear industry, TOFD is often preferred for inspecting components with thick walls, as it provides reliable sizing of flaws and enhances the probability of detection.
 - **Railway Industry:** TOFD is utilized for the inspection of rail welds, ensuring the detection of critical flaws in a cost-effective manner.

While PAUT offers real-time imaging capabilities and is well-suited for applications requiring dynamic inspections, TOFD is advantageous in scenarios where diffraction imaging provides valuable information about flaw geometry. The choice between PAUT and TOFD depends on the specific requirements of the inspection task and the characteristics of the material or component being examined.

5 Applications in Industry

➤ PAUT Applications

5.1 Aerospace

Phased Array Ultrasonic Testing (PAUT) has emerged as a critical non-destructive testing (NDT) technique with diverse applications, prominently in the aerospace industry. This advanced ultrasonic testing method utilizes an array of ultrasonic transducers to steer and focus ultrasonic beams, allowing for efficient and accurate inspections.

- **Aerostructure Inspection:** PAUT plays a pivotal role in inspecting critical components of aerospace structures, such as wings, fuselage, and engine components. Its ability to provide detailed and real-time imaging facilitates the detection of internal defects, including cracks, voids, and delamination.
- **Bonded Joint Assessment:** In aerospace manufacturing, bonded joints are prevalent, and their integrity is paramount for the structural soundness of an aircraft. PAUT allows for comprehensive evaluations of bonded joints, ensuring the absence of dis-bonding or other issues that could compromise the structural integrity.
- **Composite Material Inspection:** With the increasing use of composite materials in aerospace applications, the need for precise inspection methods has grown. PAUT excels in inspecting composite structures, providing detailed information about the internal structure and identifying defects like porosity, fibre misalignment, and impact damage.
- **Automated Inspection Systems:** The aerospace industry benefits from the automation capabilities of PAUT. Automated scanning systems equipped with PAUT technology enable rapid and reliable inspections, enhancing efficiency in high-throughput manufacturing processes.
- **Maintenance and Repair:** PAUT is an invaluable tool for maintenance and repair operations in the aerospace sector. It aids in assessing the condition of critical components, facilitating timely repairs and preventive maintenance. This contributes to the overall safety and reliability of aircraft.
- **Regulatory Compliance:** As safety standards and regulations in the aerospace industry become increasingly stringent, PAUT assists in meeting compliance requirements. Its capability to provide detailed and accurate inspection data aligns with the industry's commitment to ensuring the highest levels of safety and quality.

5.2 Oil and Gas

In the oil and gas industry, PAUT plays a vital role in the inspection of pipelines, welds, pressure vessels, and other critical infrastructure components. PAUT's ability to provide accurate and detailed imaging of internal structures makes it particularly well-suited for detecting corrosion, weld defects, and other anomalies that could compromise the integrity of oil and gas assets.

Phased Array Ultrasonic Testing (PAUT) is a versatile and advanced non-destructive testing technique widely employed in various industries, with substantial applications in the Oil and Gas sector.

- **Pipeline Inspection:** PAUT plays a pivotal role in the inspection of pipelines used in the transportation of oil and gas. Its ability to provide detailed, high-resolution images of welds and material thickness helps in detecting and assessing defects, ensuring the integrity of the pipelines.
- **Weld Inspection:** In the fabrication of oil and gas infrastructure, welding is a critical process. PAUT is employed for the inspection of welds, offering real-time imaging and precise defect characterization. This ensures the quality and safety of welded joints in pressure vessels, tanks, and structural components.
- **Corrosion Monitoring:** PAUT is instrumental in assessing and monitoring corrosion in various components such as pipes and storage tanks. By providing accurate thickness measurements, it aids in predicting potential failures due to corrosion and allows for timely maintenance and corrosion mitigation strategies.
- **In-Service Inspection:** The capability of PAUT to inspect materials in service without disrupting operations is crucial in the oil and gas industry. It facilitates the assessment of equipment and structures during their operational life, minimizing downtime and ensuring the continued safety and reliability of assets.
- **Subsea Equipment Inspection:** Subsea components, being exposed to harsh environmental conditions, require a thorough inspection. PAUT is utilized for inspecting subsea pipelines, risers, and other critical infrastructure, providing detailed imaging and accurate defect detection even in challenging underwater environments.

The application of Phased Array Ultrasonic Testing in the Oil and Gas industry is multifaceted, encompassing critical areas such as pipeline inspection, weld quality assessment, corrosion monitoring, in-service inspection, and subsea equipment examination. The continuous advancements in PAUT technology contribute significantly to the enhancement of safety, reliability, and efficiency in the exploration, production, and transportation of oil and gas resources.

5.3 Manufacturing

Phased Array Ultrasonic Testing (PAUT) has emerged as a versatile and advanced non-destructive testing (NDT) technique with widespread applications across various industries, particularly in manufacturing. This innovative technology employs multiple ultrasonic elements to generate and receive ultrasonic waves, allowing for enhanced defect detection, characterization, and imaging. The applications of PAUT in manufacturing are diverse and play a crucial role in ensuring the quality and integrity of products.

- **Weld Inspection:** PAUT is extensively utilized in the manufacturing sector for weld inspection. Its ability to generate detailed and accurate images of welds helps in identifying and characterizing weld defects such as cracks, lack of fusion, and porosity. This ensures the integrity of welded structures, contributing to the overall safety and reliability of manufacturing processes.
- **Aerospace Component Testing:** In the aerospace industry, the demand for high-quality and defect-free components is paramount. PAUT is employed for inspecting critical aerospace components, including turbine blades, engine parts, and structural elements. Its precision in detecting small defects and its capability to inspect complex geometries make it an indispensable tool for ensuring the reliability of aerospace manufacturing.
- **Composite Material Inspection:** The manufacturing of composite materials, widely used in industries such as automotive and aerospace, requires stringent quality control. PAUT is employed to inspect composite structures for delamination, voids, and other internal defects. Its ability to adapt to different materials and configurations makes it a valuable tool in ensuring the structural integrity of composite components.
- **Boiler and Pressure Vessel Testing:** In the manufacturing of boilers and pressure vessels, PAUT is utilized to inspect welds and critical joints. This ensures compliance with safety standards and regulations. By providing detailed images of internal structures, PAUT aids in identifying potential

issues such as corrosion, erosion, and weld defects, thereby enhancing the overall reliability of these essential industrial components.

Phased Array Ultrasonic Testing has proven to be an invaluable asset in the manufacturing industry, offering precise and efficient inspection capabilities. Its applications range from weld inspection to the examination of aerospace components, composite materials, and pressure vessels, contributing significantly to the quality assurance and safety standards in industrial processes. As technology continues to evolve, PAUT is likely to play an increasingly pivotal role in ensuring the integrity of manufactured products.

6 TOFD Applications

6.1 Weld Inspection

Time-of-flight diffraction (TOFD) is a powerful ultrasonic testing technique that has found extensive applications in various industries, with weld inspection being one of its prominent use cases. This non-destructive testing (NDT) method offers numerous advantages, including high sensitivity, accuracy, and efficiency, making it a preferred choice for ensuring the integrity of welded components.

- **Weld Inspection with TOFD:** TOFD plays a crucial role in the inspection of welds by providing detailed information about the size and location of defects. It employs ultrasonic waves to detect and characterize flaws such as cracks, lack of fusion, and other discontinuities in welded joints. The technique excels in providing accurate and reliable results, aiding in the assessment of weld quality.
- **Detection of Defects:** TOFD is particularly adept at detecting defects with high precision. The method involves sending ultrasonic waves through the material and analyzing the diffracted signals. This allows for the identification of the size and position of defects, facilitating a comprehensive evaluation of the weld's structural integrity.
- **Advantages of TOFD in Weld Inspection:** TOFD offers several advantages over traditional inspection methods. Its ability to provide full-volume coverage, rapid scanning capabilities, and high sensitivity make it an efficient tool for assessing the quality of welds. Additionally, TOFD is less reliant on operator interpretation, reducing the likelihood of human error.
- **Increased Productivity and Cost Savings:** The efficiency of TOFD in weld inspection contributes to increased productivity in industrial settings. The rapid and reliable detection of defects allows for timely corrective measures, preventing potential failures and minimizing downtime. This, in turn, leads to substantial cost savings in maintenance and repair.
- **Integration with Automated Systems:** TOFD seamlessly integrates with automated inspection systems, enhancing the overall efficiency of quality control processes. Automated TOFD systems can be programmed to conduct thorough inspections across large batches of welded components, ensuring consistency and reliability in the evaluation of weld integrity.
- **Industry Standards and Compliance:** TOFD has gained recognition in various industry standards for weld inspection. Its inclusion in codes and standards signifies its reliability and effectiveness in ensuring the quality and safety of welded structures. Adhering to these standards is crucial for industries to meet regulatory requirements and maintain the highest levels of safety.

The application of TOFD in weld inspection is a cornerstone in ensuring the structural integrity and safety of welded components across diverse industries. Its precision, efficiency, and compliance with industry standards make TOFD a valuable tool for quality control and risk mitigation in welding processes.

6.2 Pipeline Integrity Assessment

Time-of-Flight Diffraction (TOFD) is a non-destructive testing (NDT) technique widely employed in various industrial sectors for flaw detection and characterization. Its versatility and accuracy make it indispensable in ensuring structural integrity and safety across diverse applications.

In the oil and gas industry, pipeline integrity is paramount for safe and efficient operation. TOFD plays a crucial role in assessing the integrity of pipelines by detecting and sizing defects such as cracks, weld flaws, and corrosion. This method provides comprehensive insights into the condition of pipelines without the need for costly and time-consuming excavations or shutdowns.

TOFD offers several advantages over conventional methods like radiographic testing (RT) and ultrasonic testing (UT). Its ability to provide accurate flaw sizing, high-resolution imaging, and real-time data analysis makes it particularly suitable for assessing the integrity of pipelines, both onshore and offshore.

One significant advantage of TOFD in pipeline integrity assessment is its capability to detect and characterize defects accurately, even in challenging environments such as those with complex geometries or coatings. This makes it an invaluable tool for identifying potential failure points and implementing proactive maintenance strategies to prevent costly accidents and downtime.

Moreover, TOFD can be deployed for both initial inspection and routine monitoring, allowing operators to track the progression of defects over time and make informed decisions regarding repair or replacement. This predictive maintenance approach helps optimize asset management and extends the operational lifespan of pipelines, resulting in significant cost savings and improved safety performance.

TOFD's applications in pipeline integrity assessment exemplify its importance as a reliable and efficient NDT technique in the oil and gas industry. Its ability to provide accurate, timely, and cost-effective flaw detection makes it an indispensable tool for ensuring the continued reliability and safety of critical infrastructure.

6.3 Structural Integrity of Critical Components

Time-of-Flight Diffraction (TOFD) is an advanced ultrasonic testing technique that has gained prominence in various industries for its high precision and reliability in detecting and characterizing flaws in critical components. This non-destructive testing method utilizes ultrasonic waves to provide accurate and detailed information about the structural integrity of materials, making it an invaluable tool in ensuring the safety and reliability of critical components.

- **Detection and Sizing of Flaws:** TOFD is particularly effective in the detection and sizing of flaws such as cracks, weld defects, and other discontinuities within critical components. The technique relies on the measurement of diffracted signals generated by the flaws, allowing for precise determination of their size, depth, and orientation. This capability is crucial in preventing catastrophic failures and ensuring the structural integrity of components in industries such as aerospace, nuclear, and oil and gas.
- **Weld Inspection and Quality Assurance:** In welding applications, TOFD plays a vital role in inspecting welds for potential defects. Its ability to provide full coverage of the weld area and accurately assess the size and positioning of weld discontinuities makes it an essential tool in quality assurance processes. This is especially critical in industries where the integrity of welded joints directly impacts the overall structural stability of components.
- **Pipeline Inspection and Monitoring:** The oil and gas industry extensively employs TOFD for the inspection and monitoring of pipelines. TOFD allows for the detection of corrosion, erosion, and other defects in the pipeline walls with high accuracy. The real-time monitoring capabilities of TOFD contribute to the proactive maintenance of pipelines, ensuring the continuous and safe operation of critical infrastructure.
- **Aerospace Component Testing:** In the aerospace industry, where the reliability of components is paramount, TOFD is employed to assess the structural integrity of critical parts such as turbine blades, engine components, and aircraft structures. The technique aids in identifying hidden defects that may compromise the performance of these components, contributing to the overall safety and longevity of aerospace systems.

TOFD has emerged as a cornerstone technology in the realm of non-destructive testing, especially for ensuring the structural integrity of critical components in various industries. Its versatility, precision, and ability to provide real-time insights make it an indispensable tool in the ongoing effort to enhance safety, reliability,

and efficiency in industrial applications. As technology continues to advance, TOFD is expected to play an even more significant role in safeguarding critical infrastructure and components across diverse sectors.

6.7 Advancements and Innovations

6.7.1 Recent Technological Developments in PAUT

Recent Technological Developments in PAUT (Phased Array Ultrasonic Testing) have significantly advanced the capabilities of this non-destructive testing method, enhancing its effectiveness and reliability in various industries such as aerospace, automotive, oil and gas, and manufacturing. Two key areas of advancement include improved array configurations and enhanced signal processing algorithms, which are intricately interconnected, contributing to the overall efficiency and accuracy of PAUT systems.

6.7.2 Improved Array Configurations

Phased array ultrasonic testing relies on the use of multiple ultrasonic transducers to generate and receive ultrasonic waves. Recent advancements have led to significant improvements in array configurations, offering greater flexibility, precision, and coverage during inspections. These improvements include:

- a. **Multi-element Transducer Arrays:** Traditional PAUT systems typically consist of linear arrays with a fixed number of elements. However, recent developments have led to the introduction of multi-element transducer arrays, allowing for more complex beam steering and focusing capabilities. By adjusting the activation of individual elements within the array, inspectors can tailor the ultrasonic beam to specific geometries and flaw types, improving inspection accuracy and sensitivity.
- b. **Curved and Flexible Arrays:** Conventional linear arrays have limitations when inspecting curved surfaces or complex geometries. Advanced array configurations now include curved and flexible arrays, which conform to the shape of the component being inspected. This enables more comprehensive coverage and better resolution of defects, even in challenging inspection scenarios.
- c. **Dual Matrix Arrays:** Dual matrix arrays combine the benefits of phased array technology with the capability of matrix arrays, offering increased inspection efficiency and versatility. These arrays feature multiple rows and columns of elements, providing greater control over beam steering and focusing in both the lateral and depth directions. This results in improved defect detection and characterization, particularly in thick-section components and welds.

6.7.3 Enhanced Signal Processing Algorithms

Signal processing plays a crucial role in extracting meaningful information from ultrasonic signals received by the transducer array. Recent advancements in signal processing algorithms have greatly improved the accuracy, speed, and reliability of defect detection and characterization in PAUT inspections. Some notable developments include:

- a. **Adaptive Beamforming Techniques:** Adaptive beamforming algorithms dynamically adjust the focusing of ultrasonic beams based on real-time feedback from the inspected component. These techniques optimize the beamforming process to account for variations in material properties, geometry, and surface conditions, improving inspection sensitivity and reducing false calls.
- b. **Advanced Imaging and Reconstruction Methods:** Modern signal processing algorithms incorporate advanced imaging and reconstruction techniques, such as total focusing method (TFM) and full matrix capture (FMC), enabling high-resolution imaging of complex internal structures and defects. These methods provide detailed three-dimensional representations of the inspected component, facilitating accurate defect sizing and localization.
- c. **Machine Learning and Artificial Intelligence:** The integration of machine learning and artificial intelligence algorithms enhances the capabilities of PAUT systems by enabling automated defect

recognition and classification. By training algorithms on large datasets of ultrasonic signals and corresponding defect types, these systems can intelligently analyze and interpret inspection results in real time, improving overall inspection efficiency and reliability.

The recent advancements in PAUT technology, particularly in array configurations and signal processing algorithms, have revolutionized non-destructive testing practices across various industries. By leveraging innovative array designs and sophisticated signal processing techniques, PAUT systems can achieve higher inspection accuracy, faster inspection speeds, and greater versatility in detecting and characterizing defects, ultimately enhancing the safety and reliability of critical components and structures.

8 Recent Technological Developments in TOFD

Recent technological developments in Time-of-Flight Diffraction (TOFD) have seen significant advancements, particularly in the integration of robotics and the application of automation and artificial intelligence (AI) in data analysis. These two areas are intricately interconnected, revolutionizing the efficiency, accuracy, and reliability of TOFD inspections across various industries.

8.1 Integration with Robotics

Robotics has emerged as a game-changer in the field of non-destructive testing (NDT), including TOFD. By integrating TOFD systems with robotic platforms, companies can automate inspection processes, enhancing safety, speed, and accessibility in challenging environments. Robotic arms equipped with TOFD sensors can navigate complex geometries, confined spaces, or hazardous areas, performing inspections with precision and consistency.

The integration of TOFD with robotics offers several benefits:

- **Improved Safety:** Robotic systems can access hazardous or hard-to-reach areas, reducing the need for human intervention in potentially dangerous environments.
- **Increased Efficiency:** Robots can perform inspections continuously without fatigue, leading to faster turnaround times and increased productivity.
- **Enhanced Data Accuracy:** Precise control over robotic movements ensures consistent scanning parameters, resulting in high-quality data acquisition and analysis.
- **Cost Savings:** Automation reduces labor costs and minimizes the risk of errors or rework, optimizing overall operational expenses.

Moreover, advancements in robotic technology, such as collaborative robots (co-bots) and autonomous navigation, further enhance the versatility and adaptability of TOFD inspections across diverse industrial settings.

8.2 Automation and Artificial Intelligence in Data Analysis

The proliferation of automation and AI technologies has revolutionized data analysis in TOFD inspections, offering unparalleled capabilities in processing vast amounts of data with speed and accuracy. Automation streamlines the analysis workflow, from data acquisition to defect detection and characterization, while AI algorithms enable intelligent decision-making and predictive maintenance strategies.

Key aspects of automation and AI in TOFD data analysis include:

- **Real-time Processing:** Automated algorithms can process TOFD data in real-time, providing instant feedback during inspections and facilitating prompt decision-making.

- **Defect Recognition:** AI-powered algorithms can identify and classify defects with high precision, distinguishing between relevant indications and noise in the data.
- **Pattern Recognition:** Machine learning techniques enable the detection of subtle patterns or anomalies indicative of structural defects, enhancing the reliability of inspections.
- **Predictive Analytics:** By analyzing historical data and trend analysis, AI models can predict potential failure modes, allowing for proactive maintenance and risk mitigation strategies.
- The integration of automation and AI in TOFD data analysis not only improves the accuracy and efficiency of inspections but also enables data-driven insights for optimizing asset integrity management practices.

8.3 Interconnection between Robotics and Automation/AI

The integration of robotics with automation and AI in TOFD inspections creates a synergistic relationship, amplifying the benefits of each technology. Robotic platforms serve as the physical interface for deploying TOFD sensors in the field, while automation and AI algorithms enhance the intelligence and autonomy of these systems.

- **Robotic Control:** Automation and AI algorithms govern the movement and operation of robotic inspection platforms, orchestrating scan paths, sensor configurations, and data acquisition protocols.
- **Data Fusion:** Robotics and automation facilitate multi-sensor integration, combining TOFD data with other NDT techniques such as ultrasonic testing (UT) or phased array ultrasonics (PAUT). AI algorithms then analyze fused data streams for comprehensive defect assessment and characterization.
- **Adaptive Inspection Strategies:** AI-driven systems can adapt inspection parameters in real-time based on environmental conditions, material properties, or historical performance data, optimizing inspection outcomes and resource allocation.

By leveraging the complementary strengths of robotics, automation, and AI, TOFD inspections achieve unprecedented levels of efficiency, accuracy, and reliability, empowering industries to maintain the integrity of critical assets and infrastructure with confidence.

9 Challenges and Future Trends

A. Current Challenges in PAUT and TOFD

Phased Array Ultrasonic Testing (PAUT) and Time-of-Flight Diffraction (TOFD) are advanced non-destructive testing (NDT) techniques crucial in ensuring the integrity and safety of various structures, from pipelines to aerospace components. While both techniques have revolutionized inspection processes, they are not without their challenges, many of which are interconnected.

- **Complex Geometry Inspection:** One of the primary challenges in both PAUT and TOFD is inspecting components with complex geometries. Structures with irregular shapes, varying thicknesses, or intricate weld geometries pose difficulties in achieving comprehensive coverage and accurate defect detection. The use of conventional probes may not suffice, necessitating innovative probe designs or multi-angle scanning techniques to overcome these challenges.
- **Calibration and Standardization:** PAUT and TOFD systems require precise calibration to ensure reliable inspection results. However, achieving consistent calibration across different equipment and operators can be challenging. Standardization of calibration procedures and reference blocks is essential to mitigate discrepancies and ensure the reliability and reproducibility of inspection data.
- **Data Interpretation and Analysis:** The volume of data generated by PAUT and TOFD inspections can be overwhelming. Analyzing this data accurately and efficiently to differentiate

between relevant indications and noise is a significant challenge. Advanced signal processing algorithms and artificial intelligence (AI) techniques are being developed to automate defect recognition and classification, improving the speed and accuracy of data interpretation.

- **Surface Conditions and Coupling:** The accuracy of PAUT and TOFD inspections is highly dependent on the consistent and adequate coupling between the transducers and the inspected surface. Variations in surface conditions, such as roughness, curvature, or coatings, can affect the quality of ultrasonic signals and compromise inspection results. Developing robust techniques for maintaining consistent coupling, even in challenging environments, is crucial for reliable defect detection.
- **Depth Sizing and Resolution:** Accurately sizing defects in terms of their depth within the material is essential for assessing their criticality and determining appropriate repair actions. However, achieving precise depth sizing with PAUT and TOFD can be challenging, particularly for small or shallow defects. Improving the resolution and sensitivity of ultrasonic probes and optimizing inspection parameters can enhance depth-sizing capabilities.
- **Operator Training and Certification:** Skilled operators are essential for performing accurate and reliable PAUT and TOFD inspections. However, training personnel to be proficient and ensuring consistent competency across different operators present ongoing challenges. Establishing comprehensive training programs and certification standards that cover theoretical knowledge, practical skills, and real-world applications is critical for maintaining inspection quality and reliability.
- **Integration with Inspection Workflows:** Integrating PAUT and TOFD seamlessly into existing inspection workflows can be challenging, particularly in industries with stringent regulatory requirements and complex operational procedures. Developing software solutions that facilitate data management, analysis, and reporting, while ensuring compliance with industry standards, is essential for maximizing the efficiency and effectiveness of these inspection techniques.

Addressing these interconnected challenges requires collaboration between industry stakeholders, equipment manufacturers, regulatory bodies, and research institutions. By advancing technology, standardization efforts, and operator training, the reliability and effectiveness of PAUT and TOFD inspections can be enhanced, contributing to safer and more reliable infrastructure across various sectors.

B. Emerging Trends and Future Directions

In today's rapidly evolving industrial landscape, two key trends stand out as pivotal in shaping the future direction of manufacturing and production: Integration with Industry 4.0 and an increased focus on environmental sustainability and safety concerns. While these may seem like disparate paths, they are deeply interconnected, offering mutually reinforcing benefits and opportunities for innovation.

Integration with Industry 4.0:

Industry 4.0 represents the convergence of digital technologies and physical systems within manufacturing environments. It encompasses concepts such as the Internet of Things (IoT), artificial intelligence (AI), big data analytics, and automation. The primary goal of Industry 4.0 is to create smart factories that are interconnected, flexible, and capable of autonomous decision-making.

Through the adoption of Industry 4.0 technologies, manufacturers gain the ability to optimize production processes, improve efficiency, and enhance product quality. Real-time data analytics enable predictive maintenance, minimizing downtime and reducing the likelihood of costly equipment failures. Automation streamlines workflows, allowing for greater precision and consistency in manufacturing operations. Additionally, interconnected systems facilitate seamless communication across the entire production chain, from suppliers to end-users.

Increased Focus on Environmental and Safety Concerns:

Environmental sustainability and safety have become critical priorities for industries worldwide. The imperative to mitigate climate change, minimize resource depletion, and reduce pollution has prompted businesses to reevaluate their practices and embrace more eco-friendly alternatives. Similarly, ensuring the well-being of workers and communities has become a non-negotiable aspect of corporate responsibility.

Measures to address environmental concerns include the adoption of renewable energy sources, the implementation of energy-efficient technologies, and the reduction of waste and emissions. Safety initiatives encompass the implementation of stringent protocols, the use of advanced monitoring systems, and the provision of comprehensive training programs for employees.

Interconnected Synergies:

The integration of Industry 4.0 with a heightened focus on environmental sustainability and safety concerns creates a powerful synergy that amplifies the benefits of both trends:

- **Efficiency and Resource Optimization:** Industry 4.0 technologies enable manufacturers to optimize resource utilization and minimize waste through data-driven insights and predictive analytics. By reducing resource consumption and emissions, companies can simultaneously enhance their environmental performance and improve operational efficiency.
- **Risk Mitigation and Compliance:** The digitization and automation of manufacturing processes enhance safety by reducing the potential for human error and ensuring compliance with regulatory standards. Advanced monitoring systems can detect safety hazards in real-time, allowing for immediate intervention and risk mitigation measures.
- **Innovation and Competitive Advantage:** Embracing sustainability and safety as core principles fosters a culture of innovation within organizations. Companies that prioritize these values are more likely to develop cutting-edge technologies and solutions that not only enhance their competitiveness but also contribute to the greater good of society.
- **Stakeholder Trust and Reputation:** Demonstrating a commitment to environmental stewardship and worker safety enhances corporate reputation and fosters trust among customers, investors, and the broader community. By aligning their operations with ethical and sustainable practices, companies can build stronger relationships with stakeholders and secure long-term viability.

In conclusion, the integration of Industry 4.0 with a heightened focus on environmental sustainability and safety concerns represents a transformative paradigm shift in manufacturing and production. By embracing these interconnected trends, businesses can not only drive innovation and efficiency but also fulfill their responsibilities as responsible corporate citizens, creating a more sustainable and equitable future for generations to come.

LITERATURE REVIEW

In the oil and gas industry, ensuring the integrity of welds is crucial for maintaining safety and preventing costly failures. Traditional inspection methods, such as radiography, have limitations, especially when dealing with complex geometries and thick materials. Ultrasonic examination techniques, particularly Time-Of-Flight Diffraction (TOFD), have emerged as reliable alternatives, offering high-resolution imaging capabilities and the ability to detect a wide range of discontinuities. This literature review aims to explore the application of TOFD for weld inspection in the oil and gas industry, with a focus on its integration with supplementary techniques like phased array ultrasonics and manual ultrasonic testing (UT) to cover blind zones and detect specific discontinuities.

TOFD in Weld Inspection

TOFD has gained popularity in weld inspection due to its ability to provide accurate sizing and characterization of flaws, such as cracks, lack of fusion, and porosity. Patel et al. (2019) discuss its application in the oil and gas industry, highlighting its effectiveness in inspecting ferrous plate and piping butt weld joints. The technique offers advantages over conventional methods by providing real-time imaging and precise defect localization, enhancing inspection efficiency and reliability.

Integration with Phased Array Ultrasonics

While TOFD excels in detecting planar defects within its inspection range, it may have blind zones, particularly in complex geometries or near the weld root. To address this limitation, phased array ultrasonics are often employed as a supplementary technique. Phased array probes allow for beam steering and focusing, enabling coverage of TOFD blind zones and improved defect detection in challenging geometries. This integration enhances the overall inspection coverage and reliability of the examination process, as outlined in industry guidelines such as ASME Sec. VIII Div. 1 and ASME B31.3.

Manual UT for Specific Discontinuities

Despite the capabilities of TOFD and phased array ultrasonics, certain discontinuities, such as transverse and laminar defects, may require additional scrutiny. Manual UT offers a complementary approach for detecting these specific discontinuities, providing detailed characterization and assessment. Integrating manual UT into the inspection procedure ensures comprehensive defect detection and evaluation, particularly in critical areas where the risk of failure is high.

Considerations for Complex Geometries and Alternative Materials

While TOFD and supplementary techniques offer significant advantages in weld inspection, complex geometries and alternative materials pose challenges that require special consideration. Non-standard geometries and materials may affect sound propagation and signal interpretation, necessitating customized inspection strategies and parameter adjustments. Research efforts are ongoing to address these challenges and optimize inspection techniques for diverse applications within the oil and gas industry.

Conclusion

The integration of TOFD with phased array ultrasonics and manual UT represents a comprehensive approach to weld inspection in the oil and gas industry, offering enhanced defect detection capabilities and reliability. While these techniques demonstrate significant advancements, ongoing research and development are

essential to address challenges posed by complex geometries and alternative materials. By continually refining inspection methodologies and leveraging emerging technologies, the industry can further improve safety standards and operational efficiency in weld inspection processes.



METHODOLOGY

1.0 SCOPE

- This general procedure represents guidelines provided in ASME Sec. VIII Div. 1, ASME Sec. VIII Div. 2 and ASME B31.3 for weld inspection of ferrous Plate and piping butt weld joints using TOFD as main technique, phased array as a supplementary technique to cover TOFD blind zones and Manual UT to detect transverse and laminar discontinuities.
- This document details the procedure by which ultrasonic examination of Carbon steel and LTCS butt weldments will be performed using the Time-Of-Flight-Diffraction. It is relevant to weld joints having single or double V-shaped geometry having a material thickness of 25mm and above and pipe diameter 6" and above.
- Complex geometries and alternative materials will require special consideration.

2.0 REFERENCES

2.1 ASME Sec. V – Article 4 –Ed. 2017

- ASME Sec. V article-4 mandatory appendix III for TOFD
- ASME Sec. V article-4 mandatory appendix V for phased array
- ASME Sec. V article-4 for pulse-echo to detect transverse indication and lamination.
- ASME Sec. V article-4 mandatory appendix IX-procedure qualification requirements for flaw sizing and categorization.
- ASME Sec. V article-4 mandatory appendix VIII- Ultrasonic Examination Requirement for A Fracture based acceptance criteria.
- ASME Section V, Article 1 Mandatory Appendix II-Supplemental personal qualification requirement for NDE certification

2.2 ASNT-SNT-TC-1A – 2016 Recommended Practice for Non-Destructive Testing Personnel

2.3 ASME B 31.3 2015 Process piping

2.4 Code case 181-2015 Use of alternative ultrasonic examination acceptance criteria in ASME B 31.3

2.9 ASME Sec. VIII Div. 1 Rules for Construction of Pressure Vessel

2.6 ASME Sec. VIII Div. 2 Alternative rules of construction of pressure vessels

3.0 PERSONNEL QUALIFICATION

Personnel performing this inspection shall be certified to at least NDT Level II as per ASNT SNT-TC-1A. Only Level III personnel shall analyze the data or interpret the results. Qualification records of certified personnel shall be maintained and submitted to the company for approval.

Personnel who acquire and analyze ultrasonic examination data shall be trained using the equipment including hardware and software in 6.0 below and they shall take part in the demonstration.

Personal Qualification requirement when Phased array Ultrasonic testing (PAUT) and Time of flight diffraction (TOFD) is used, shall meet the requirement of ASME Section V Article 1, Mandatory Appendix II. Supplement Personal Qualification Requirement for NDE Certification

4.0 OBJECTIVE

- 4.1 To utilize the advantage of TOFD and Phased array technique which produces a real-time image indicating the presence of flaws if any and their lengths and through-wall dimensions.

- 4.2 Data will be recorded in unprocessed form for TOFD and PA. Further data processing may be made (e.g. file straightening) for image print out and reporting.
- 4.3 The TOFD examination area shall include the volume of the weld plus lesser of 25mm or t, on each side of the weld for material less than 200mm. Alternatively, examination volume may be reduced to include the actual HAZ plus 6mm of base material beyond the HAZ on each side of weld provided extent of weld HAZ is measured and documented during WQP.
- 4.3.1 TOFD blind zones shall be covered with encoded Phased array technique.

5.0 DEFINITIONS

5.1 WORDS AND EXPRESSIONS

5.1.1 In this method statement, the following words and expressions are used and they have the following respective meanings assigned to them, except where the context requires.

5.1.2 TOFD: Time of Flight Diffraction

5.1.3 PA: Phased Array

5.1.4 PE: Pulse Echo

5.1.5 MUT: Manual Ultrasonic Testing

5.1.6 SDH: Side drill hole.

5.1.7 FSH: Full-Screen Height

5.1.8 TCG: time correction gain

5.1.9 DAC: distance amplitude correction curve

5.1.10 PCS: probe centre separation

6.0 EQUIPMENT

The ultrasonic examination shall be performed using the following equipment:

Equipment	Trade Name, Type
Data Acquisition System/Software	Omni scan MX 2 with 16: 128 or 32: 128 or 32:128 PR channel for TOFD and PAUT Manufactured By: Olympus (Canada)
	Tomoview software 2.9 R10 or equivalent Epoch LT: for MUT Manufactured By: Olympus (Canada)
Scanner	Chain scanner / HSMT-Flex/ Weld ROVER /Manual scanner



6.1 TRANSDUCER AND WEDGE

6.1.1 TRANSDUCER SELECTION

Type of Probe	Centre Frequency	Crystal Size	Wave Propagation	Manufacturer
TOFD Broad Band Longitudinal Wave	10/7.5/5/2.25MHz	10mm/6mm/3mm	Longitudinal	Phoenix/Pentametric
2.25L-64-A2	2.25 MHz	48 X 12 mm	Longitudinal	Olympus
5L-64-A2	5 MHz	38.4 X 10mm	Longitudinal	Olympus
5L-32-A5	5 MHz	19.2 X 20 mm	Longitudinal	Olympus
5L-60-A14	5 MHz	60 X 10 mm	Longitudinal	Olympus
5L-16-A10	5 MHz	9.6 X 10 mm	Longitudinal	Olympus

6.2 WEDGES:

Type of Wedges	Refracted Angle	Identification	Type of wave propagation
----------------	-----------------	----------------	--------------------------

			in material
TOFD wedge	45, 60 or 70 Degree	ST1-60L- IH S	Longitudinal Shear
		ST1-70L- IH S	
		ST1-45L-IH S	
		ST2-60L- IH S	
		ST2-70L- IH S	
		ST2-45L-IH S	
Phased Array wedges	55	SA2-N55S-IHC	Shear wave
	60	SA5-N60S-IHC	
	55	SA14-N55S-IHC	
	55	SA10-N55S-IHC	

Note : 1) TOFD and phased array probe diameter and frequency selection based on demonstration.

2) Other equivalent make probe and wedge may be used based on demonstration.

3) Two probes shall be used in pitch catch arrangement

4) Each probe in the TOFD pair shall have the same Nominal frequency

5) The TOFD probe having same element dimension

6) Probe may be focus or unfocused, unfocused probe are recommended for detection and focused probe are recommended for improved resolution for sizing

6.3 COUPLANT

Water or water + paper paste shall be used as a couplant. Couplant used for calibration and testing shall be the same.

7.0 EQUIPMENT

7.1 EQUIPMENT FOR TOFD AND PAUT

TOFD instrument shall be calibrated every year and after any maintenance has been carried out.

7.1.1 INSTRUMENT

The instrument shall provide a linear “A” scan presentation for both setting up scan parameters and for signal analysis. Instrument linearity shall be such that the accuracy of the indicated amplitude or time is $\pm 5\%$ of the actual full-scale amplitude of time. The ultrasonic pulses may provide excitation voltage by turn burst, unipolar or bipolar square wave. Pulse width shall be tunable to allow optimization to pulse amplitude and duration. The bandwidth of the ultrasonic receiver shall be at least equal to that of the nominal probe frequency and such that the -6dB bandwidth of the probe does not fall outside of the -6dB bandwidth of the receiver. Receiver gain control shall be available to adjust signal amplitude in increments of 1 dB or less. Pre-amplifiers may be included in the system. Analog to digital conversion of waveforms shall have a sampling rate at least four times that of the nominal

frequency of the probe. When digital signal processing is to be carried out on the raw data, this shall be increased to eight times the nominal frequency of the probe.

7.1.2 DATA DISPLAY AND RECORDING

The data display shall allow for the viewing of the unrectified A-scan so as to position the start and length of gate that determine the A-scan time is recorded. Equipment shall permit storage of all gated a scan to a magnetic or optical storage medium. Equipment shall provide sectional view of the weld with a minimum of 64 gray scale levels. Computer software for TOFD display shall include an algorithm to linearize cursor or the waveform time- base to permit depth and vertical extent estimations. In addition to storage of waveform data including amplitude and time-based detail, the equipment shall also store positional information indicating the relative position of the wave-form concerning the adjacent waveform.

7.2 EQUIPMENT CALIBRATION FOR TOFD AND PAUT

7.2.1 SCREEN HEIGHT LINEARITY

Screen height linearity shall be checked as per ASME Sec. V Mandatory Appendix I and II

Couple a straight beam probe to IIW V1 block or any calibration block that provide amplitude differences with sufficient signal separation to prevent overlapping of the two signals Select any two echoes whose amplitude are in the ratio of 2:1 with larger echo set at 80% of full screen height and smaller indication at 40% of FSH. Without moving the search unit, adjust the gain to successively set the larger indication from 100% to 20% of full screen height, in 10% increments or 2 dB steps if a fine control is not available, and read the smaller indication at each setting. The reading must be 50% of the larger Amplitude, within 5% of full screen height. The setting and reading must be estimated to nearest 1% of full screen height.

7.2.2 AMPLITUDE CONTROL LINEARITY

Screen height linearity shall be checked as per ASME Sec. V Mandatory Appendix I and II

Couple an angle beam probe to IIW – V1 block or any other convenient reflector from any calibration block and get multiple echoes from the 100mm quadrant. Select any echo and note its amplitude. Reduce the gain by 6 dB and read the amplitude of the same indication. It must be 50% of the initial amplitude within 20 % of the nominal amplitude ratio. Perform this exercise for full range of the gain. The settings and readings must be estimated to the nearest 1% of full screen and the readings shall be as shown in the following table

AMPLITUDE CONTROL LINEARITY

INDICATION SET AT % OF FULL SCREEN HEIGHT	dB CONTROL CHANGE	INDICATION LIMITS % OF FULL SCREEN HEIGHT
80 %	- 6 dB	35 to 45 %
80 %	-12 dB	15 to 25 %
40 %	+ 6 dB	65 to 95 %
20 %	+12 dB	65 to 95 %

7.2.3 TIME BASE LINEARITY (Horizontal Linearity)

Select any compressional wave probe and configure the phased array instrument to display a range suitable to obtain at least ten multiple backreaction from a block of a known thickness. the 25 mm wall thickness of the IIW V1 block shall be taken for that. Using the reference and measurement cursors determine the interval between each multiple and record the interval of the first 10 multiple. Generally, the error on the multiples should not exceeds ± 0.5 mm for a steel plate. Screen height linearity and amplitude control linearity of phased array equipment checked prior to use than after every year.

7.2.4 DETERMINATION OF PHASED ARRAY PROBE ELEMENT ACTIVITY

Connect the phased array probe to be tested to the Phased array ultrasonic instrument and remove any delay line or refracting wedge from the probe. Acoustically couple the probe to the 25 mm thickness of IIW V1 block with a uniform layer of couplant. Configure an electronic scan consisting of one element that is stepped along one element at a time for the total number of elements in the array. Set the pulsar parameter such that pulse echo response shall be 80 ± 5 % of FSH for each element. Observed A -scan display for each element in the array and record the receiver gain required the 80% Signal amplitude for each element. The PA probe shall be removed from service if it is determined that more than 10 % of elements or 2 or more adjacent element deemed inactive & receiver gain shall be within ± 2 dB of each other. PA probe element activity shall be carried out every week and report as in attachment K shall be record.

Screen height linearity, amplitude control linearity and Time base Linearity of phased array equipment shall be performed monthly and submitted to contractor as format in Attachment G and H.

8.0 BASIC CALIBRATION BLOCKS FOR TOFD TECHNIQUE

8.1 REFLECTOR

SDH (side drill hole) shall be used to confirm adequate sensitivity setting. SDH size shall be based on thickness of the weld under examination.

8.2 MATERIAL

The material from which the block is fabricated shall be of the same product form, and material specification or equivalent P – Number grouping as one of the materials being examined. For the purpose of this procedure, P-Nos. 1, 3, 4, and 5A through 5C and 15A through 15F materials are considered equivalent.

8.3 QUALITY

Prior to fabrication, the block material shall be completely examined with a straight beam search unit. Areas that contain an indication exceeding the remaining back-wall reflection shall be excluded from the beam paths required to reach the various calibration reflectors.

8.4 HEAT TREATMENT

The calibration block shall receive at least the minimum tempering treatment required by the material specification for the type and grade. If the calibration block contains welds other than cladding, and the component weld at the time of the examination has been heat treated, the block shall receive the same heat treatment.

8.5 SURFACE FINISH

The finish on the scanning surfaces of the block shall be representative of the scanning surface finishes on the component to be examined.

8.6 RANGE OF CALIBRATION BLOCK THICKNESS

The block thickness shall be at $\pm 10\%$ of the nominal thickness of the piece to be examined for thickness up to 4 in. (100 mm) or ± 0.4 inch (10 mm) for thickness over 4 in. (100 mm).

8.7 BLOCK CURVATURE

8.7.1 MATERIALS WITH DIAMETERS GREATER THAN 20 In. (500 mm)

For examinations in materials where the examination surface diameter is or greater than 20 in. (500mm), a block of essentially the same curvature, or alternatively, a flat basic calibration block, may be used.

8.7.2 MATERIALS WITH DIAMETERS 20 In. (500 mm) AND LESS

For examinations in materials where the examination surface diameter is equal to or less than 20 in. (500 mm), a curved block shall be used. Except where otherwise stated in this procedure, a single curved basic calibration block may be used for examinations in the range of curvature from 0.9 to 1.5 times the basic calibration block diameter. For example, an 8 in (200 mm) diameter block may be used to calibrate for examinations on surfaces in the range of curvature from 7.2 in. to 12 in. (180 mm to 300 mm) in diameter.

8.8 BASIC CALIBRATION BLOCK

The basic calibration block configuration and reflector shall be as per attachment B If weld is divided in multiple zones; minimum two holes per each zone shall be required. Refer attachment B for example calibration block.

9.0 CALIBRATION FOR TOFD TECHNIQUE

9.1 SENSITIVITY SETTING

Set the TOFD probe on the surface to be utilized for calibration and set the gain control so that the lateral wave amplitude is from 40%-90% of the full screen and noise level is less than 5-10 % Full screen height. This is reference sensitivity. For multiple zone examination, when lateral wave is not display or beardy discernible set the gain control based solely on the noise level.

9.2 CONFORMATION OF SENSITIVITY

Scan the calibration block's SDH with them center between the probes, at the reference level set in 9.1 SDH responses from require zone shall be minimum of 6 dB above the grain noise and shall be apparent in the resulting digitized grayscale display. For multiple zone examination repeat 9.1 for each TOFD probe pair, the nearest SDH in adjacent Zone shall be detected.

9.3 WIDTH OF COVERAGE

Two additional scans as per 9.1 and 9.2 shall be made with the probe offset to either side of applicable zone's weld edge ± 0.5 inch (13 mm). If all the required holes are not detected, two additional offset scans are required with the probe offset by distance identified above. Refer attachment C for width for coverage conformation.

9.4 ENCODER

The positional encoder shall be moved through a measured distance of 20 inch (500mm). The system read-out shall be within $\pm 1\%$ (5mm) of the measured distance. Encoder failing this check shall be recalibrated and this check repeated. Encoder calibration shall be carried out before starting of each day's shift.

9.5 SYSTEM CONFORMATION SCAN

The calibration block shall be scanned and reference reflector indication recorded to conform that prior to and at the completion of each examination or series of similar examination, when examination personal is changed, and if scan plan are modifies.

10.0 BASIC CALIBRATION BLOCK FOR PAUT

10.1 REFLECTOR

NOTCH (Rectangular notch) shall be used to establish primary response of the equipment for Pipe-to-pipe weld joints. For Palte to Plate weld join side drill Holes (SDH) shall be used to establish primary referecne level.

10.2 MATERIAL

The material from which the block is fabricated shall be of the same product form, and material specification or equivalent P – Number grouping as one of the materials being examined. For this procedure, P-Nos. 1, 3, 4, and 5A through 5C and 15A through 15F materials are considered equivalent.

10.3 QUALITY

Before fabrication, the block material shall be completely examined with a straight beam search unit. Areas that contain an indication exceeding the remaining back-wall reflection shall be excluded from the beam paths required to reach the various calibration reflectors.

10.4 HEAT TREATMENT

The calibration block shall receive at least the minimum tempering treatment required by the material specification for the type and grade. If the calibration block contains welds other than cladding, and the component weld at the time of the examination has been heat treated, the block shall receive the same heat treatment.

10.5 SURFACE FINISH

The finish on the scanning surfaces of the block shall be representative of the scanning surface finishes on the component to be examined.



10.6 BLOCK CURVATURE

10.6.1 MATERIALS WITH DIAMETERS GREATER THAN 20 In. (500 mm)

For examinations in materials where the examination surface diameter is greater than 20 in. (500 mm), a block of essentially the same curvature, or a flat basic calibration block, may be used.

10.6.2 MATERIALS WITH DIAMETERS 20 In. (500 mm) and Less

For examinations in materials where the examination surface diameter is equal to or less than 20 in. (500 mm), a curved block shall be used. Except where otherwise stated in this procedure, a single curved basic calibration block may be used for examinations in the range of curvature from 0.9 to 1.5 times the basic calibration block diameter. For example, an 8 in (200 mm) diameter block may be used to calibrate for examinations on surfaces in the range of curvature from 7.2 in. to 12 in. (180 mm to 300 mm) in diameter.

10.7 BLOCK THICKNESS RANGE

Block thickness (T) shall be within less of 6 mm or 25 % of the material thickness.

11.0 CALIBRATION FOR PAUT

11.1 CALIBRATION FOR PAUT

11.1.1 PAUT shall be carried out to cover blind zones (top and bottom) of TOFD. Select the first appropriate scan plan (either linear or sectorial scan) to cover blind zones.

- 11.1.2** Primary set-up used during calibration shall be used for weld joint examination.
- 11.1.3** All individual beams used in the examination shall be calibrated to provide the measurement of distance and amplitude correction over the sound path employed in the examination.
- 11.1.4** PAUT calibration is including wedge delay, sensitivity and TCG.
- 11.1.5** Element Checking shall be done before selecting the focal laws. Once all Elements are found active after wedge delay calibration and sensitivity calibration shall be started.
- 11.1.6** The Wedge Delay Calibration shall be calibrated for True Depth with the angles used in calibration
- 11.1.7** The Sensitivity Calibration/Focal law balancing will provide the required gain adjustments for each refracted angle and sound path used. The range of response from adjacent elements shall not vary more than ± 3 dB.
- 11.1.8** Peak up the signal from the calibration reflector and scan the phased array probe backwards through all the different angles or focal laws.
- 11.1.9** Scan forward over the calibration reflector through all the refracted angles or focal laws.
- 11.1.10** The system will calculate the required gain needed at each focal law to adjust the amount needed
- 11.1.11** A Time Corrected Gain (TCG) calibration shall be used to compensate for attenuation in the material at the sound paths utilized during calibration and examination.
- 11.1.12** After finishing of TCG, set up is saved in storage device of machine.
- 11.1.13** Scanning sensitivity shall be +6dB to primary reference level.
- 11.1.14** Scanning speed during the weld examination shall not be more than the scanning speed during the procedure demonstration/qualification.

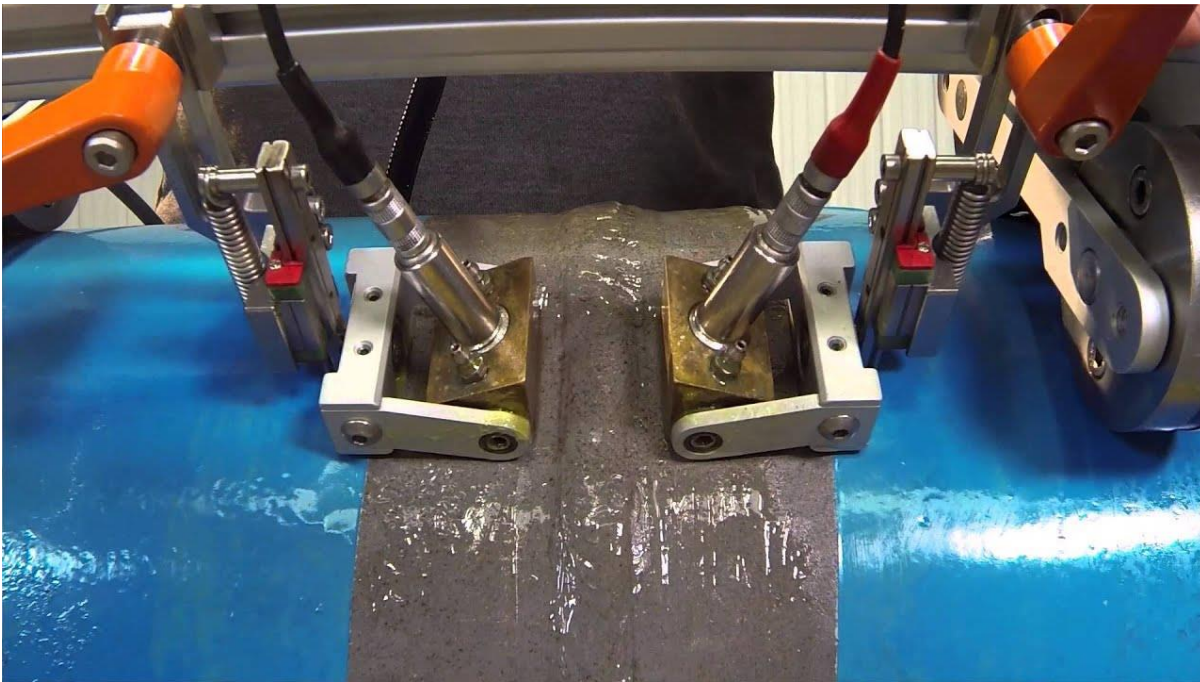

11.2 CALIBRATION FOR PE

PE shall be carried out for searching laminar reflectors and transverse weld discontinuities.

12.0 EXAMINATION COVERAGE FOR PA TECHNIQUE.

Each linear scan shall be parallel to the weld axis at a constant standoff distance with the beam oriented perpendicular to the weld axis.

- 1) The search unit shall be maintained at a fixed distance from the weld axis by a fixed guide or mechanical means.
- 2) The examination angle (s) for the E-scan and range of angle for the s-scan shall be appropriate for the joint to be examined.
- 3) Scanning speed shall be such that data drop-out is less than 2 data lines pair inch (25 mm) of the linear scan length and that there are no adjacent data line skips.
- 4) For the E-scan technique, the overlap between adjacent active apertures (aperture increment change) shall be a minimum of 50% of the active aperture height
- 5) For the S-scan technique, the angular sweep incremental change shall be a maximum 1 deg or sufficient to ensure 50 % beam overlap
- 6) When multiple linear scans are required to cover the required volume of weld and base material, overlap between adjacent linear scans shall be a minimum of 10 % of the effective aperture height for E-scan or beam width for S-scan
- 7) Automatic Computer-enhanced data acquisition shall be used to obtain a permanent record of full weld to demonstrate the absence, or not, of linear type discontinuities with amplitudes exceeding the reference level.

13.0 DEMONSTRATION OR QUALIFICATION BLOCK

13.1 MATERIAL

As per clause 8.2 of this procedure

13.2 QUALITY

As per clause 8.3 of this procedure

13.3 HEAT TREATMENT

As per clause 8.4 of this procedure

13.4 SURFACE FINISHING

As per clause 8.5 of this procedure

13.5 BLOCK CURVATURE

As per clause 8.7 of this procedure

13.6 DEMONSTRATION BLOCK

13.6.1 Demonstration block shall be prepared by welding or provide the acoustic properties are similar, the hot isotopic process may be used

13.6.2 The demonstration block shall be within 25 % of the thickness to be examined. For welding joining two different thicknesses of material, demonstration block thickness shall be based on the thinner of the two materials

13.6.3 The demonstration block's weld joint geometry shall be representative of the production joint's detail.

13.6.4 the demonstration block contains a minimum of three planer flaws or three EDM notches oriented to simulate flaws parallel to the production weld's axis and major groove faces. The flaws shall be located as follows

- 1) one surface flaw on the side of the block representing the component O.D surface
- 2) one surface flaw on the side of the block representing the component I.D surface
- 3) one Sub-surface flaw

When the scan plan to be utilized subdivides a weld into multiple examination zones, a minimum of one flaw per zone is required.

13.7 FLAW SIZE

Demonstration block flaw sizes shall be based on the demonstration block thickness and no longer than that specified by Acceptance criteria of applicable codes, additionally

- a) Maximum through height for material less than 25 mm thick.

b) 0.25 aspect ratio acceptable flaw for material equal to or greater than 1 inch thick.

13.8 ONE SIDE EXAMINATION.

When the obstruction, the weld examination can only be performed from one side of the weld axis, If TOFD can perform with offset scanning, shall be demonstrated on same configuration demonstration block. For One side examination the demonstration block shall contain two sets of flaws. One set on each side of the weld axis. When demonstration block can be scanned from both side of the weld axis during the qualification scan, then only one set of flaw is required.

13.9 FLAW SIZING AND CATEGORY

Flaw shall be sized and categorised in accordance with the written procedure being qualified.

13.10 AUTOMATIC AND SEMIAUTOMATIC ACCEPTANCE CRITERIA

Acceptable performance is define as the detection of all the flaws in the demonstration block and

- 1) Recorded response or imaged length as exceeds the specified evaluation criteria
- 2) The flaw are sized as being equal to or greater than their actual size (i.e.. both length and height)
- 3) Flaw are properly categorized (i.e.. surface or sub surface)

13.11 SUPPLEMENTAL MANUAL TECHNIQUE(S) ACCEPTABLE PERFORMANCE

Supplemental manual technique is used to detect transverse indication and if any confirmation is required on TOFD and PAUT indications.

13.12 DEMONSTRATION BLOCK RECORDS

The following information shall be recorded

- 1) The information specified by procedure being qualified
- 2) Demonstration block thickness, joint geometry including any cladding or weld overlay, and flaw data (i.e.. position in block, size (length and height), separation distance to nearest surface, category (surface or sub surface)).
- 3) Scanning sensitivity and scanning travel speed
- 4) Qualification scans data
- 5) Flaw sizing data

6) Supplemental manual technique sizing data if applicable.

14.0 SCAN PLAN

14.1 SCAN PLAN FOR TOFD

Scan plan showing transducer position and movement, PCS, Type of transducer and frequency and component coverage that provide a standard and repeatable methodology for weld acceptance. Scan plan should also include ultrasonic beam angle to be used, beam direction with respect to centerline and weld material volume to be examined. Actual scan plan shall be qualified on demonstration block mentioned in 13.0

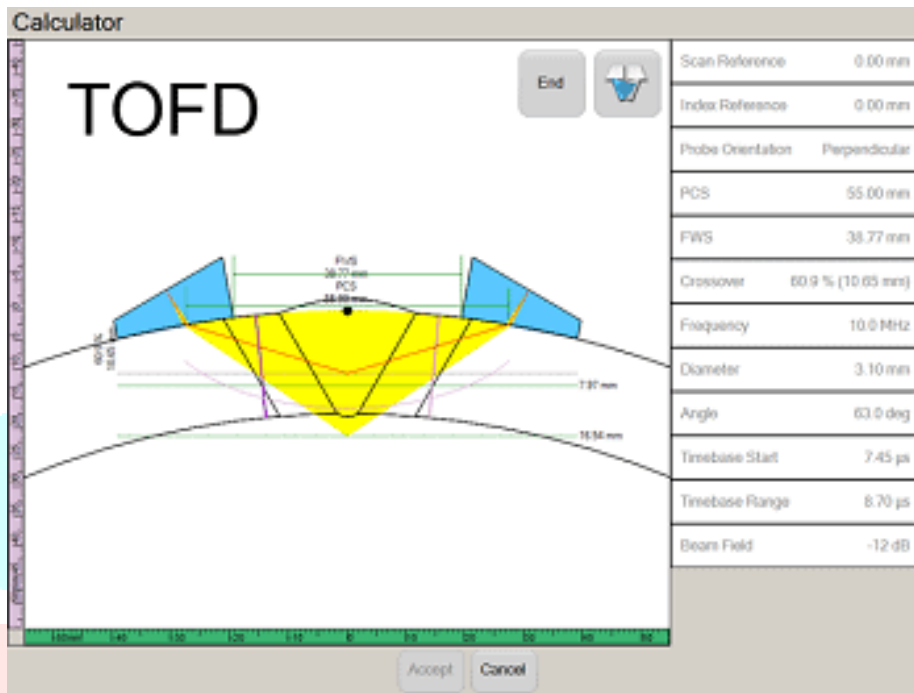

14.2 SCAN PLAN FOR PAUT

Scan plan showing transducer position and movement, focal law, Type of transducer and frequency and component coverage that provide a standard and repeatable methodology for weld acceptance. Scan plan should also include ultrasonic beam angle to be used, beam direction with respect to centerline and weld material volume to be examined. Actual scan plan shall be qualified on demonstration block mentioned in 13.0

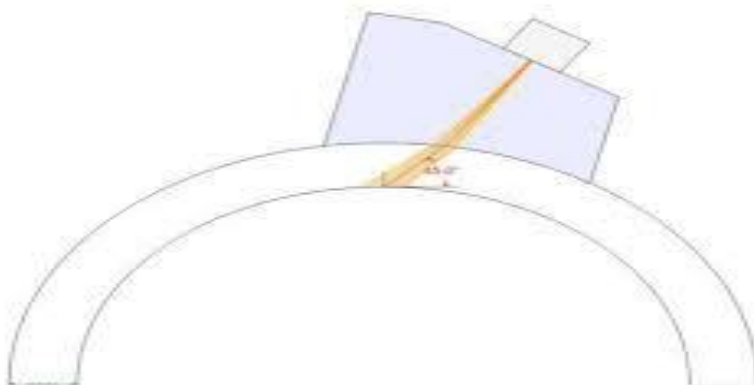

15.0 EXAMINATION FOR TOFD TECHNIQUE.

15.1 EXAMINATION COVERAGE

The ultrasonic examination area of coverage shall include the volume of weld, plus the lesser of 25 mm (1 in.) Or t on each side of weld.

15.2 DATA SAMPLING SPACING

A maximum sample spacing of 0.04 in. (1 mm) shall be used between A-scans collected for thicknesses under 2 in. (50 mm) and a sample spacing of up to 0.080 in. (2mm) may be used for thicknesses greater than 2 in. (50 mm).

15.3 MISSING DATA LINES

Missing lines in the display shall not exceed 5% of the scan lines to be collected, and no adjacent lines shall be missed.

15.4 SCAN LENGTHS & OVERLAP

Each scan shall be collected in maximum lengths of 3000mm and there shall be a minimum of 25mm overlap between successive scans.

15.5 THICKNESS CHECK

A free run shall be made on the measuring block. The distance between the lateral wave and first back wall signal shall be within ± 0.04 inch (1.0 mm) of the block's measured thickness. Set-ups failing this check shall have the probe separation distance either adjusted or its programmed value changed and this check repeated. For multiple zones examinations where the back wall is not displayed or barely discernible, a side-drill hole or other known depth reference reflector in the calibration may be used.

15.6 GATE SETTING

Un-rectified (RF waveform) A-scan signal shall be recorded. A-scan gated region shall be set to start just prior to the lateral wave (generally 1 μ S) and End to the mode convert signal (generally after 1 μ S).

15.7 SCANNING SENSITIVITY

The scanning sensitivity level shall not be exceeding than that qualified.

15.8 RATE OF SEARCH UNIT MOVEMENT

The rate of search unit movement shall not exceed than that qualify.

16.0 SURFACE PRAPARATION

The base metal on both side of the weld shall be free of weld spatter, surface irregularities "OR" foreign materials that might interfere the examination.

Where the weld surfaces interfere with examination, the weld shall be prepared as needed to permit the examination.

17.0 SCANNING PROCEDURE FOR TOFD AND PAUT

The scanning shall include the volume of the weld and HAZ (ie.25mm or 't' from each side of the weld toe). The contractor shall provide the drawings for the joint preparation and dimensions of the weld to be examined.

The data shall be collected with the Scanning speed which is based on demonstration. The collected data shall be presented in the Top display (D scan) image representing distance along the weld.

Mechanical holder shall be used to ensure that probe spacing is maintained at a fixed distance. The mechanical holder shall also ensure that alignment to the intended scan axis on the examination piece is maintained. Probe motion may be achieved using motorizes or manual means and the mechanical holder for the probe shall be equipped with a positional encoder that is synchronized with the sampling of A-scans.

Phased array presentation shall be in A-scan, S-scan and B-scan or C scan and Height and length of the flaw shall be measured in B-scan.

Manual shear wave scans shall be performed for transverse and laminar discontinuities.

18.0 SYSTEM CALIBRATION VERIFICATION FOR TOFD & PAUT

- 1) With any substitution of the same type and length of search unit cable.
- 2) With any substitution of power utilizing the same type source (e.g., change of batteries)
- 3) At least every 4 hours during the examination
- 4) At the completion of a series of examinations
- 5) Whenever the validity of the calibration is in doubt and when examination personnel are changed.

19.0 EVALUATION OR DATA ANALYSIS CRITERIA

19.1 FOR AMPLITUDE BASED TECHNIQUE (PAUT OR MUT)

The location of amplitude and extent of all reflectors that produce a response greater than 20 % of the reference level shall be investigated.

19.2 FOR NON-AMPLITUDE BASED TECHNIQUE (TOFD)

Indication images that have indicated lengths greater than the following shall be evaluated in terms of the acceptance criteria of the referencing code section.

- 4 mm for welds in material equal to or less than 38mm Thick.
- 5 mm for welds in material greater than 38mm Thick. But less than 100mm Thick.
- 19 mm, whichever is less, for welds in material greater than 100mm

For welds joining two different thicknesses of material, material thickness shall be based on thinner of the two materials.

20.0 GEOMETRIC INDICATION

Ultrasonic indications of geometric and metallurgical origin shall be classified as follows:

Indication that are determined to originate from the surface configurations (such as weld reinforcement or root geometry) or variations in metallurgical structure of materials (such as cladding to base material interface) may be classified as geometric indications, and

- 1) Need not be characterized or sized in accordance with (i) (3) Code Case 181
- 2) Need not be compared with allowable flaw size acceptance criteria of table 1 or 2 as given below
- 3) The maximum indication amplitude and location shall be recorded.

The following steps shall be taken to classify an indication as geometric :

- 1) Interpret the area containing the reflector in accordance with the applicable examination procedure.
- 2) Plot and verify the reflector coordinates provide a cross sectional display showing the reflector position and surface discontinuity such as root or counter bore:
- 3) Review fabrication or weld prep drawings.

Alternatively, other NDE methods may be applied to classify an indication as geometric (e.g., alternative UT beam angles, radiography). The method employed is for information only to classify the indication as geometric and ASME B 31.3 requirements for examination techniques are only required to the extent that they are applicable.

21.0 FLAW SIZING

- 21.1 The dimensions of the flaw shall be determined by the rectangle that fully contains the area of the flaw (see below figure).

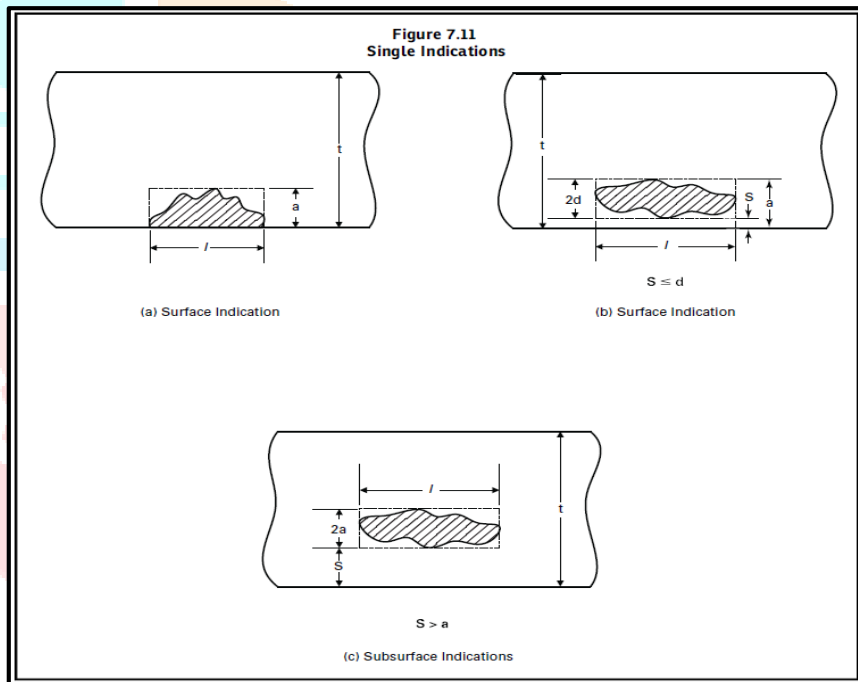

- a) The length (l) of the flaw shall be drawn parallel to the inside pressure-retaining surface of the component.
- b) The depth of the flaw shall be drawn normal to the inside pressure retaining surface and shall be denoted as " a " for a surface flaw or " $2a$ " for a subsurface flaw.

Figure.1

Figure 7.12
Multiple Planar Flaws Oriented in a Plane Normal to the Pressure Retaining Surface

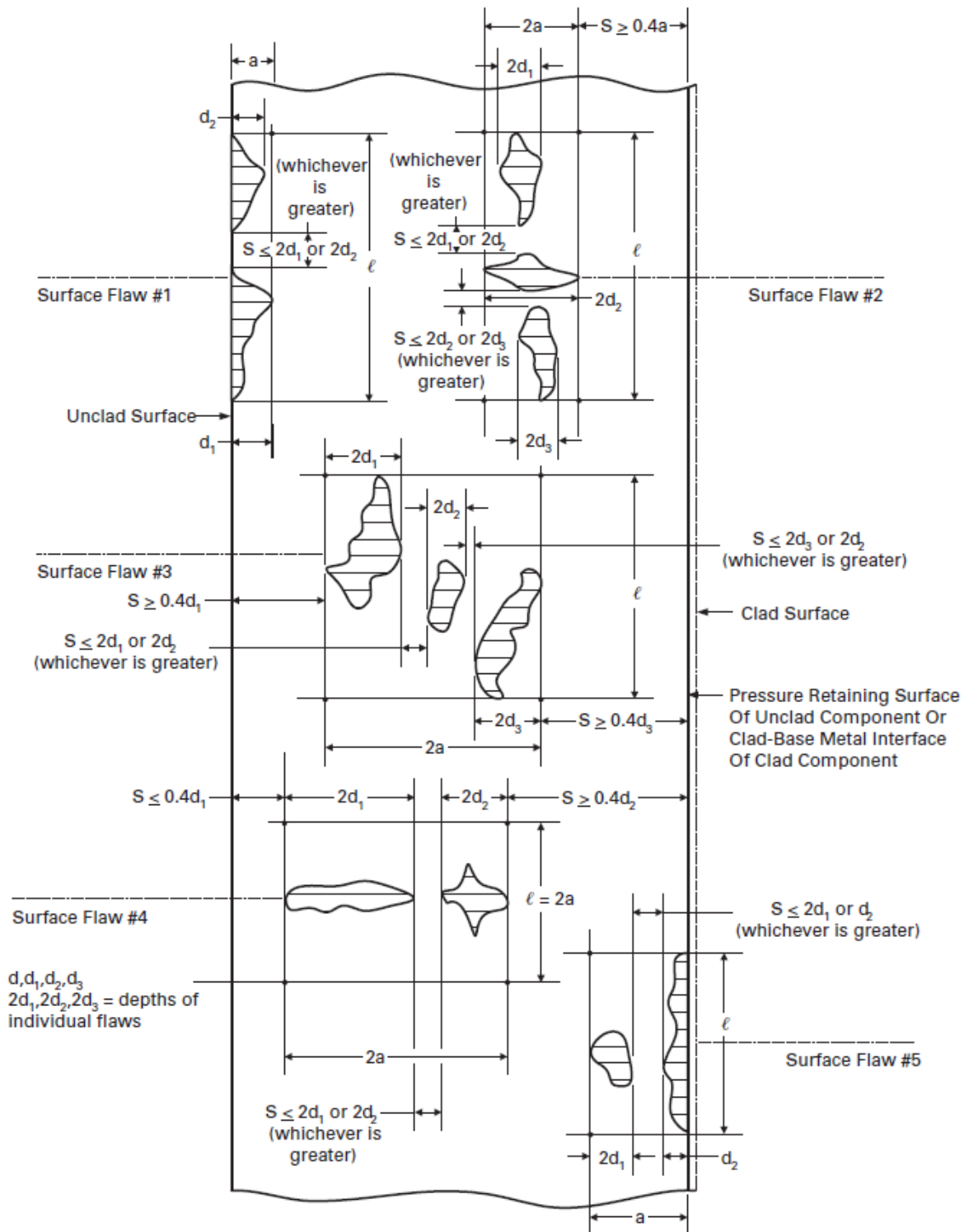

Figure -02

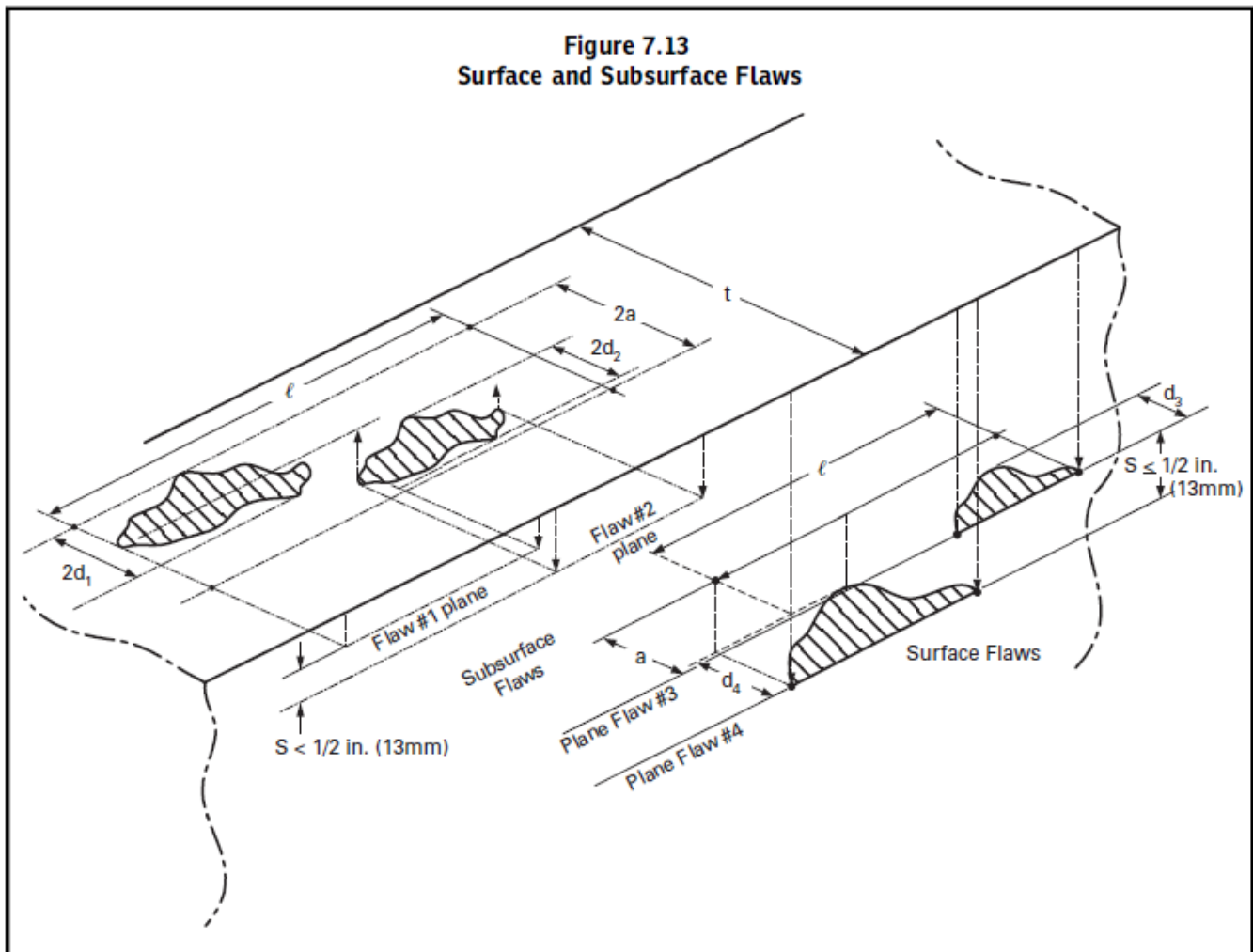
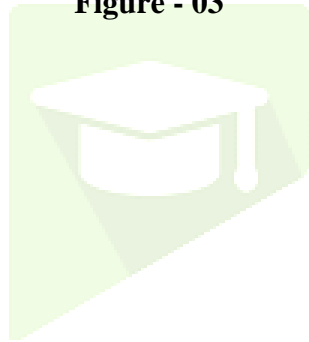
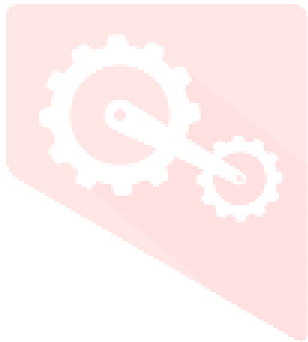

Figure - 03



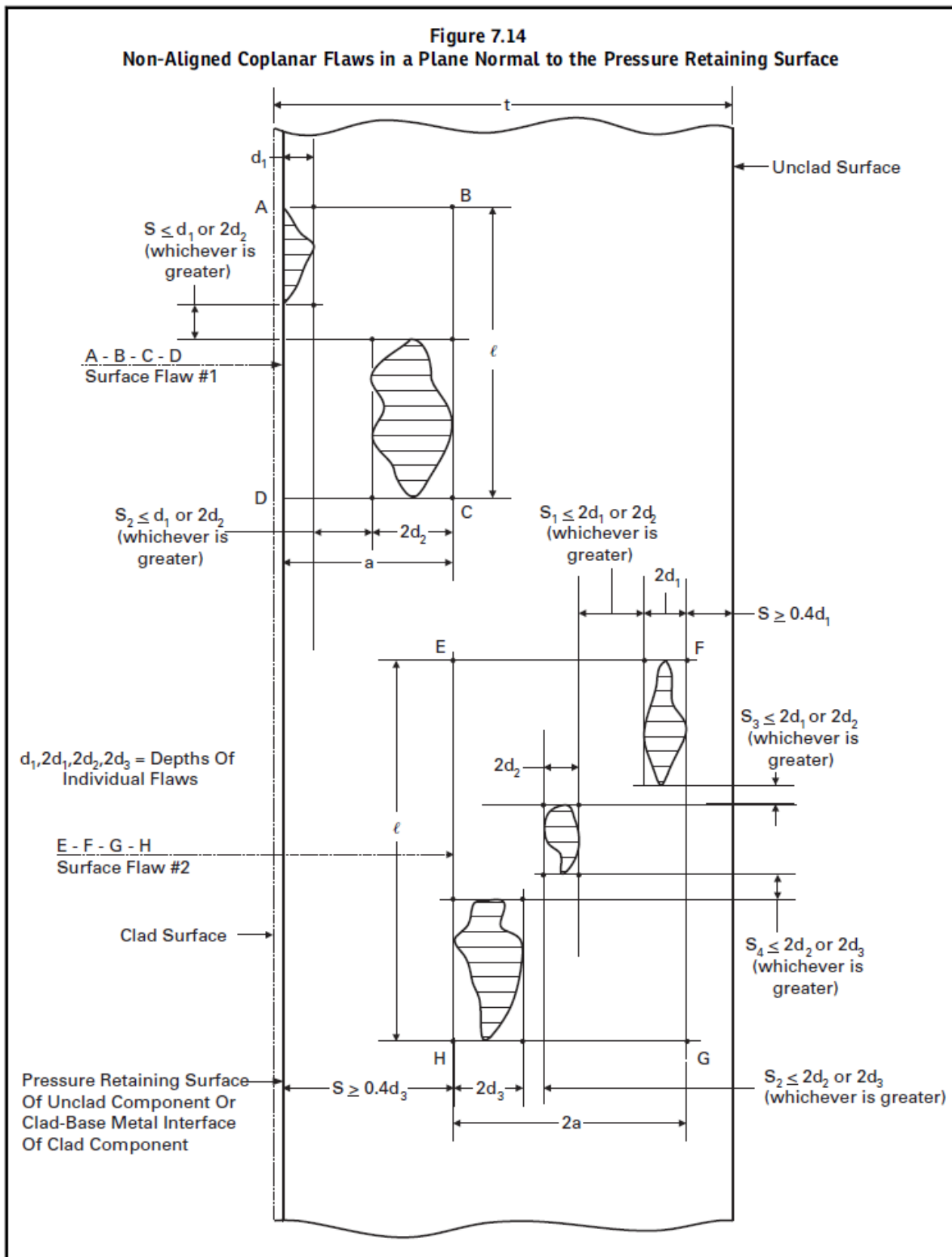
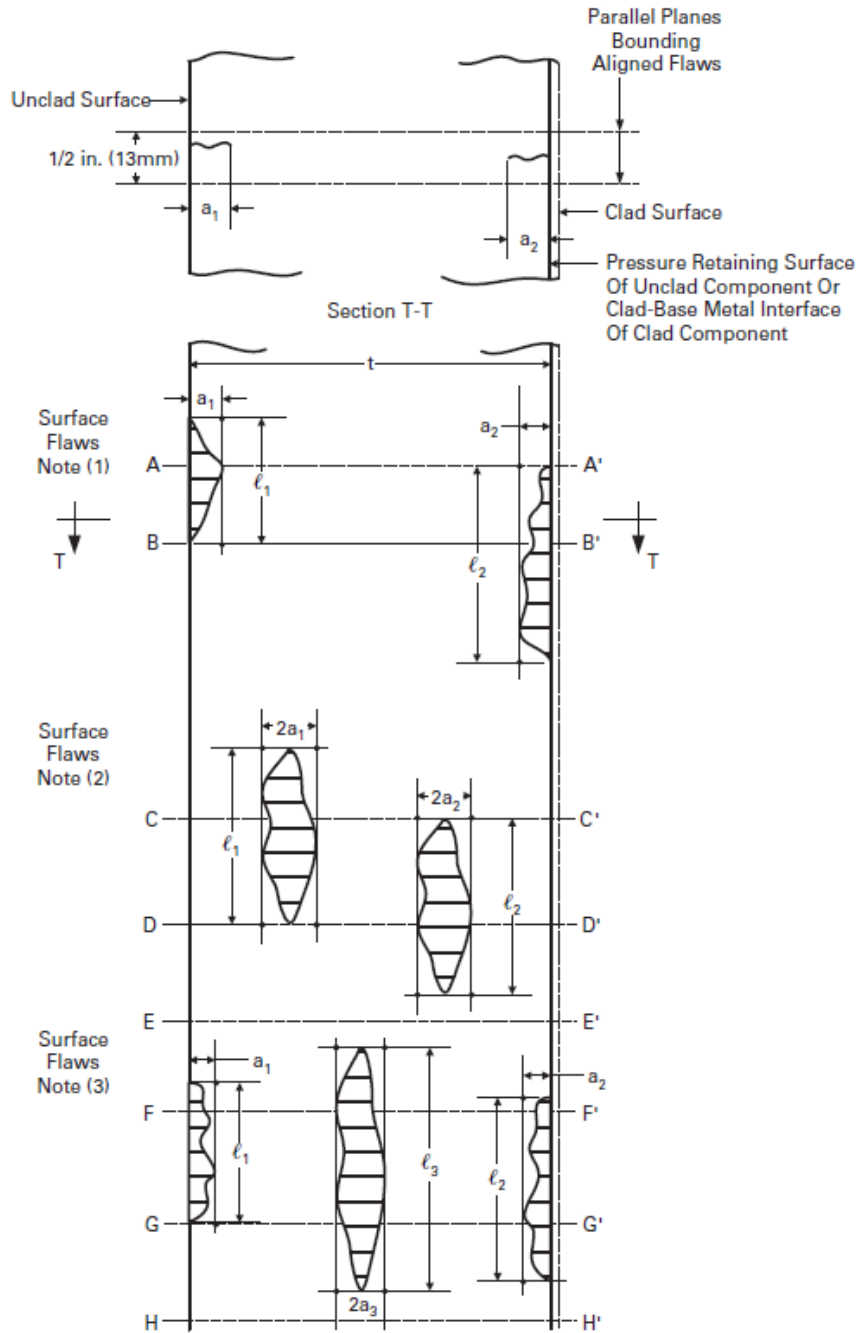

Figure 7.15
Multiple Aligned Planar Flaws



NOTES:

(1) This illustration indicates two surface flaws. The first, a_1 , is on the outer surface, and the second, a_2 , is on the inner surface:

$$(a_1 + a_2) \leq (a_s + a_s^*)/2 \text{ within planes } A - A' \text{ and } B - B'$$

(2) This illustration indicates two subsurface flaws: $(a_1 + a_2) \leq (a_e + a_e^*)/2$ within planes C - C' and D - D'

(3) This illustration indicates two surface flaws and one subsurface flaw.

Figure - 05

22.0 FLAW EVALUATION AND ACCEPTANCE CRITERIA

Flaws shall be evaluated for acceptance using the applicable criteria of Tables 7.8, 7.9 or 7.10, and with the following additional requirements. Unacceptable flaws shall be repaired and the repaired welds shall be reevaluated for acceptance. (Refer Attachment I for Acceptance criteria Table)

22.1 Surface Flaws – Flaws identified as surface flaws during the UT examination may or may not be surface connected. Therefore, unless the UT data analysis confirms that the flaw is not surface connected, it shall be considered surface connected or a flaw open to the surface, and is unacceptable unless surface examination is performed. If the flaw is surface connected, the requirements above still apply. However, in no case shall the flaw exceed the acceptance criteria in this Division for the material employed.

Acceptance surface examination techniques are as follows:

- 1) Magnetic particle examination (MT) in accordance with Applicable code
- 2) Liquid penetrant examination (PT) in accordance with Applicable code
- 3) Eddy Current examination (ET) in accordance with Applicable code

22.2 MULTIPLE FLAWS

- 1) Discontinuous flaws shall be considered a singular planar flaw if the distance between adjacent flaws is equal to or less than the dimension S as shown in Figure 2.
- 2) Discontinuous flaws that are oriented primarily in parallel planes shall be considered a singular planar flaw if the distance between the adjacent planes is equal to or less than 13 mm (1/2 in) (see Figure 3).
- 3) Discontinuous flaws that are coplanar and nonaligned in the through-wall thickness direction of the component shall be considered a singular planar flaw if the distance between adjacent flaws is equal to or less than S as shown in Figure 4.
- 4) Discontinuous flaws that are coplanar in the through-wall direction within two parallel planes 13 mm (1/2 in) apart (i.e., normal to the pressure-retaining surface of the component) are unacceptable if the additive flaw depth dimension of the flaws exceeds those shown in Figure 5.

22.3 Subsurface Flaws – Table 7.8, 7.9 and 7.10 table shall be followed, additionally any discontinuity length (l) shall not exceed 4t.

23.0 REPORTING

Automatic Computer enhanced data acquisition shall be used to obtain permanent record of full weld to demonstrate the absence, or not, of linear type discontinuities with amplitudes exceeds the reference level.

Report shall include below mention detail.

- 1) Procedure Identification and revision
- 2) Equipment Identification and detail
- 3) Search unit Details
- 4) PCS and scan detail
- 5) Search unit cable(s) used , type and length
- 6) Beam angle used
- 7) Couplant used
- 8) Calibration and Qualification Block details
- 9) Computerized program identification and revision when used.
- 10) Reference Gain and scanning Gain
- 11) Weld Identification and thickness
- 12) Weld Volume coverage
- 13) Examination Surface

- 14) Record of rejected Indication
- 15) Restricted Area details
- 16) Special equipment when used (search unit, wedge, shoe, automatic scanning equipment, recording equipment ...et)
- 17) Instrument reference level gain and , if used, damping and reject setting
- 18) Calibration scan Data & Report to be Submitted
- 19) Identification and location of weld or volume scanned
- 20) Surface from which examination was conducted including surface condition
- 21) Examination personal identification
- 22) PCS
- 23) Data sampling spacing
- 24) Flaw height
- 25) The final data processing level
- 26) Search unit element size, number, pitch and Gap dimension
- 27) Focal law parameter, including as applicable ,angle or angular range, focal depth and plane, element numbered used, angular or element incremental change, and start and stop number or start element number
- 28) Wedge natural refracted angle
- 29) Scan plan and Report to be submitted
- 30) Supplemental manual technique(s) indication data
- 31) Scanner and adhering and guiding mechanism.





PART: B

PHASED ARRAY ULTRASONIC TESTING (PAUT)

1.0 SCOPE

- This general procedure represent guidelines provided in ASME Sec. VIII Div. 1, ASME Sec. VIII Div. 2 and ASME B31.3 for the purpose of weld inspection of ferrous piping and plate butt joints using Phased array as a main technique and MUT for searching transverse and laminar discontinuities.
- This document details the procedure by which ultrasonic examination of Carbon steel, LTCS and Low Alloy Steels butt elements will be performed using the Phased array. It is relevant to weld joints having single or double V-shaped geometry having weld thickness 6mm and above, and Curvature from 2" and above. This procedure is applicable to pipe to pipe, pipe to fitting, shell to nozzle and shell to dish end weld joints.
- This procedure is also apply above 13mm where only one side scanning accessible.
- Complex geometries and alternative materials will require special consideration.

2.0 REFERENCES

2.1 ASME Sec. V – Article 4 –Ed. 2017

- ASME Sec.V article-4 mandatory appendix III for TOFD
- ASME Sec.V article-4 mandatory appendix V for phased array
- ASME Sec.V article-4 for pulse echo to detect transverse indication and lamination.
- ASME Sec.V article-4 mandatory appendix IX-procedure qualification requirements for flaw sizing and categorization.
- ASME Sec.V article-4 mandatory appendix VIII- Ultrasonic Examination Requirement for A Fracture based acceptance criteria.

➤ ASME Section V, Article 1 Mandatory Appendix II-Supplemental personal qualification requirement for NDE certification

- 2.2 ASNT-SNT-TC-1A – 2016 Recommended Practice for Non-Destructive Testing Personnel
- 2.3 ASME B 31.3 2015-Process piping
- 2.4 Code case 181-2015-use of alternative ultrasonic examination acceptance criteria in ASME B 31.3
- 2.5 ASME Sec. VIII Div 1 Ed. 2017– Rules for construction of Pressure vessels
- 2.6 ASME Sec. VIII Div. 2 Ed.2017– Alternative rules for construction of Pressure vessels

3.0 PERSONNEL QUALIFICATION

Personnel performing this inspection shall be certified to at least NDT Level II as per ASNT SNT-TC-1A. Only Level III personnel shall analyze the data or interpret the results. Qualification records of certified personnel shall be maintained and submitted to the company for approval.

Personnel who acquire and analyze ultrasonic examination data shall be trained using the equipment including hardware and software in 6.0 below and they shall be taken part in demonstration.

Personal Qualification requirement when Phased array Ultrasonic testing (PAUT) and Time of flight diffraction (TOFD) is used , shall meet requirement of ASME Section V Article 1, Mandatory Appendix II. suppliment personal qualificaiton requirement for NDE certification

4.0 DEFINITION

- 4.1.1 PA: Phased Array
- 4.1.2 MUT: Manual Ultrasonic Testing
- 4.1.3 SDH: Side drill hole.
- 4.1.4 FSH : Full Screen Height
- 4.1.5 TCG : time correction gain
- 4.1.6 DAC : distance amplitude correction curve
- 4.1.7 EDM: Electro Discharge Machining

5.0 EQUIPMENT

The ultrasonic examination shall be performed using the following equipment:

Equipment	Trade Name, Type
Data Acquisition System/Software	Omni scan MX 2 with 16: 128, 32:128 and 32:128 PR - channel for PA Manufactured By : Olympus
	Tomoview software 2.9 R10 or equivalent
	Epoch LT for MUT Manufactured By : Olympus
Scanner	Chain scanner / HSMT-Flex/ Weld ROVER / Versa mouse

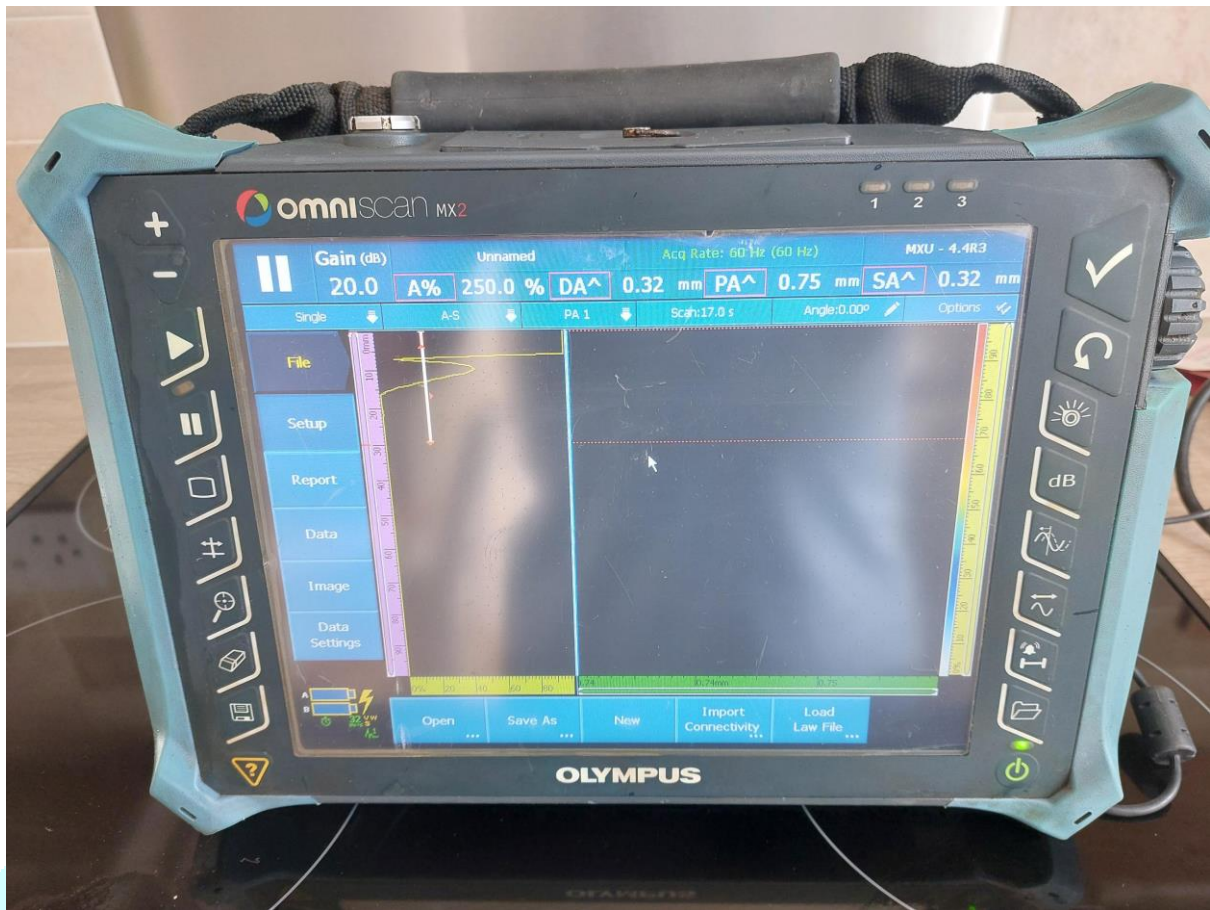

5.1 TRANSDUCER AND WEDGE

5.1.1 TRANSDUCER SELECTION

Type of PAUT probe	Center Frequency	Crystal Size	Wave propagation	Manufacturer
5L-16-A10	5MHz	9.6 X 10mm	Longitudinal	Olympus /
5L-60-A14	5MHz	60 X 10mm	Longitudinal	Olympus /
2.25L-64-A2	2.25MHz	48 X 12mm	Longitudinal	Olympus /
5L-64-A2	5MHz	38.4 X 10	Longitudinal	Olympus /
5L-32-A5	5MHz	19.2 X 20	Longitudinal	Olympus /

5.1.2 WEDGES

Manufacturer	Refracted Angle	Identification	Type of wave
Olympus / Doppler	55	SA10-N55S-IHC	Shear Wave
Olympus / Doppler	55	SA14-N55S-IHC	Shear Wave
Olympus / Doppler	55	SA2-N55S-IHC	Shear Wave
Olympus / Doppler	55	SA5-N55S-IHC	Shear Wave

Other

equivalent probes and wedges may be used ,after satisfactorily demonstration.

5.2 COUPLANT

Water or water + paper paste shall be used as a couplant. Couplant used for calibration and for testing shall be same.

6.0 EQUIPMENT CALIBRATION

6.1 SCREEN HEIGHT LINEARITY:

Screen height linearity shall be checked as per ASME Sec. V clause T- 461.1

Couple a straight beam probe to IIW V1 block and get multiple echoes from 25mm back-wall. Select any two echoes whose amplitude are in the ratio of 2:1 with larger echo set at 80% of full screen height. Without moving the search unit, adjust the gain to successively set the set the larger indication from 100% to 20% of full screen height, in 10% increments or 2 dB steps if a fine control is not available, and read the smaller indication at each setting. The reading must be 50% of the larger Amplitude, within 5% of full screen height. The setting and reading must be estimated to nearest 1% of full screen height. Screen height linearity shall be varified every month and documented in format-Refer Attachment H.

6.2 AMPLITUDE CONTROL LINEARITY

Amplitude control linearity shall be checked as per ASME Sec.V, clause T-461.2

Couple an angle beam probe to IIW – V1 block and get multiple echoes from 100mm quadrant. Select any echo and note its amplitude. Reduce the gain by 6 dB and read the amplitude of same indication. It must be 50% of the initial amplitude within 20 % of the nominal amplitude ratio. Perform this exercise for full range of the gain. The settings and readings must be estimated to the nearest 1% of full screen and the readings shall be as shown in the following table. Screen height linearity shall be varified every month and documented in format-Refer Attachment I.

AMPLITUDE CONTROL LINEARITY

INDICATION SET AT % OF FULL SCREEN HEIGHT	dB CONTROL CHANGE	INDICATION LIMITS % OF FULL SCREEN HEIGHT
80 %	- 6 dB	35 to 45 %
80 %	-12 dB	15 to 25 %
40 %	+ 6 dB	65 to 95 %
20 %	+12 dB	65 to 95 %

6.3 TIME BASE LINEARITY (HORIZONTAL LINEARITY)

Select any compressional wave probe and configure the phased array instrument to display a range suitable to obtain at least ten multiple backreaction from a block of a known thickness. the 25 mm wall thickness of the IIW V1 block shall be taken for that. Using the reference and measurement cursors determine the interval between each multiple and record the interval of the first 10 multiple. Generally, the error on the multiples should not exceeds ± 0.5 mm for a steel plate.

Screen height linearity, amplitude control linearity and Time base Linearity of phased array equipment shall be performed monthly and submitted to contractor as format in Attachment H

6.4 DETERMINATION OF PHASED ARRAY PROBE ELEMENT ACTIVITY

Connect the phased array probe to be tested to the Phased array ultrasonic instrument and remove any delay line or refracting wedge from the probe. Acoustically couple the probe to the 25 mm thickness of IIW V1 block with a uniform layer of couplant. Configure an electronic scan consisting of one element that is stepped along one element at a time for the total number of elements in the array. Set the pulsar parameter such that pulse echo response shall be 80 ± 5 % of FSH for each element. Observed A -scan display for each element in the array and record the receiver gain required the 80% Signal amplitude for each element. The PA probe shall be removed from service if it is determined that more than 10 % of elements or 2 or more adjacent element deemed inactive & receiver gain shall be within ± 2 dB of each other. PA probe element activity shall be carried out every week and report as in attachment K shall be record.

Screen height linearity and amplitude control linearity of phased array equipment shall be carried out every year and shall be verified every month as per attached format- Refer Attachment -H and I.

7.0 BASIC CALIBRATION BLOCK

7.1 REFLECTOR

For plate weld joints SDH shall be used as the primary reference level and Notch shall be used for piping weld joints primary reference level establishment. Location of reflector as per attachment B

7.2 MATERIAL

The material from which the block is fabricated shall be of the same product form, and material specification or equivalent P – Number grouping as one of the materials being examined. For the purpose of this procedure, P-Nos. 1, 3, 4, and 5A through 5C and 15A through 15F materials are considered equivalent.

7.3 QUALITY

Prior to fabrication, the block material shall be completely examined with a straight beam search unit. Areas that contain an indication exceeding the remaining back-wall reflection shall be excluded from the beam paths required to reach the various calibration reflectors.

7.4 HEAT TREATMENT

The calibration block shall receive at least the minimum tempering treatment required by the material specification for the type and grade. If the calibration block contains welds other than cladding, and the component weld at the time of the examination has been heat treated, the block shall receive the same heat treatment.

7.5 SURFACE FINISH

The finish on the scanning surfaces of the block shall be representative of the scanning surface finishes on the component to be examined.

7.6 BLOCK CURVATURE

7.6.1 MATERIALS WITH DIAMETERS GREATER THAN 20 IN. (500 mm)

For examinations in materials where the examination surface diameter is or greater than 20 in. (500 mm), a block of essentially the same curvature, or alternatively, a flat basic calibration block, may be used. (Refer attachment B)



7.6.2 MATERIALS WITH DIAMETERS 20 IN. (500 mm) AND LESS.

For examinations in materials where the examination surface diameter is equal to or less than 20 in. (500 mm), a curved block shall be used. Except where otherwise stated in this procedure, a single curved basic calibration block may be used for examinations in the range of curvature from 0.9 to 1.5 times the basic calibration block diameter. For example, an 8 in (200 mm) diameter block may be used to calibrate for examinations on surfaces in the range of curvature from 7.2 in. To 12 in. (180 mm to 300 mm) in diameter. (Refer Attachment C)

7.7 THICKNESS RANGE

Calibration block shall be as per ASME Sec. V article IV T-434.2.1 and demonstration block shall be within lesser of 6 mm or 25 % of the thickness to be examined.

8.0 CALIBRATION

8.1 SYSTEM CALIBRATION

8.1.1 Focal to be used during examination shall be used for calibration.

8.1.2 All individual beam used in the examination shall be calibrated to provide measurement of distance and amplitude correction over the sound path employed in the examination.

8.1.3 PAUT calibration is including wedge delay, sensitivity and TCG.

8.1.4 Element checking shall be done prior to select the focal laws. Once all elements found active after wedge delay calibration and sensitivity calibration shall be start.

8.1.5 The wedge delay/probe delay calibration shall be calibrated for true depth with the angles used in calibration.

8.1.6 The sensitivity calibration/focal law balancing will provide the required gain adjustments for each refracted angle and sound path used. The range of response from adjacent elements shall not vary more than ± 3 dB.

8.1.7 Peak up signal from the calibration reflector and scan the phased array probe backwards through all the different angles or focal laws.

8.1.8 Scan forward over the calibration reflector through all the refracted angles or focal laws.

8.1.9 The system will calculate the required gain needed at each focal law to adjust the amount needed

8.1.10 Time corrected gain (TCG) calibration shall be used to compensate for attenuation in the material at the sound paths utilized during calibration and examination.

8.1.11 After finishing of TCG, set up is saved in storage device of machine.

8.1.12 Scanning sensitivity shall be +6dB to primary reference level

8.1.13 Rate of search movement not greater than qualification

8.2 SYSTEM CALIBRATION VERIFICATION

System calibration verification shall include the entire examination system. Sweep range and TCG calibration shall be verified on the appropriate calibration block or simulator block, as applicable, under the following conditions:

- With any substitution of the same type and length of search unit cable.
- With any substitution of power utilizing the same type source (e.g., a change of batteries)
- At least every 4 hours during the examination
- At the completion of a series of examinations
- Whenever the validity of the calibration is in doubt and when examination personnel are changed

8.3 CONFORMANCE ACCEPTANCE VALUE

8.3.1 DISTANCE RANGE POINTS

If any distance range point has moved on the sweep line by more than 10 % of the distance reading or 5% of full sweep, whichever is greater, correct the distance range calibration and note the correction in the examination record. All recorded indications since the last valid calibration or calibration check shall be re-examined and their values shall be changed on the data sheets or re-recorded.

8.3.2 SENSITIVITY SETTING

If any sensitivity setting has changed by more than 20% or 2 dB of its amplitude, correct the sensitivity calibration and note the correction in the examination record. If the sensitivity setting has decreased, all data sheets since the last valid calibration check shall be marked void and the area covered by the voided data shall be re-examined. If the sensitivity setting has increased, all recorded indications since the last valid calibration or calibration check shall be re-examined and their values shall be changed on the data sheets or re-recorded.

8.4 ENCODER

The encoder shall be calibrated by moving the scanner along 500mm on a flat surface. The distance recorded by the encoder shall be within $\pm 1\%$ of actual distance traveled. The calibration shall be made at the starting of each shift.

8.5 GATE SETTING

Gate start position, length shall be such a way that it covers HAZ and weld volume. For Zone discrimination gate setting shall be such a way that overlaps between adjacent zones.

9.0 EXAMINATION COVERAGE

Each linear scan shall be parallel to the weld axis at a constant standoff distance with the beam oriented perpendicular to the weld axis.

- 1) The search unit shall be maintained at a fixed distance from the weld axis by a fixed guide or mechanical means.
- 2) The examination angle (s) for E-scan and range of angle for s-scan shall be appropriate for the joint to be examined.
- 3) Scanning speed shall be such that data drop-out is less than 2 data lines pair inch (25 mm) of the linear scan length and that there are no adjacent data line skips.
- 4) For E-scan technique, overlap between adjacent active apertures (aperture increment change) shall be a minimum of 50% of the active aperture height
- 5) For S-scan technique, the angular sweep incremental change shall be a maximum 1 deg or sufficient to assure 50 % beam overlap
- 6) when multiple linear scan are required to cover the required volume of weld and base material, overlap between adjacent linear scan shall be a minimum of 10 % of the effective aperture height for E-scan or beam width for S-scan

9.1 RECORDING

A-scan data shall be recorded for the area of interest in an unprocessed form with no threshold, at a minimum digitization rate of five times the examination frequency, and recording increments of maximum of

- 1) 0.04 in (1mm) for material < 75 mm thick
- 2) 0.08 in (2mm) for material >75 mm thick.

Automatic Computer enhanced data acquisition shall be used to obtain permanent record of full weld to demonstrate the absence, or not, of linear type discontinuities with amplitudes exceeds the reference level.



10.0 DEMONSTRATION OR QUALIFICATION BLOCK

10.1 MATERIAL

As per clause 7.2 of this procedure

10.2 QUALITY

As per clause 7.3 of this procedure

10.3 HEAT TREATMENT

As per clause 7.4 of this procedure

10.4 SURFACE FINISHING

As per clause 7.5 of this procedure

10.5 BLOCK CURVATURE

As per clause 7.7 of this procedure

10.6 DEMONSTRATION BLOCK

10.6.1 Demonstration block shall be prepared by welding or provide the acoustic properties are similar, the hot isotopic process may be used

10.6.2 The demonstration block shall be within 25 % of the thickness to be examined. For weld joining two different thicknesses of material, demonstration block thickness shall be based on the thinner of the two materials

10.6.3 The demonstration block's weld joint geometry shall be representative of the production joint's detail.

10.6.4 The demonstration block contains a minimum of three planer flaws or three EDM notches oriented to simulate flaws parallel to the production weld's axis and major groove faces. The flaws shall be located as follow:

- 1) One surface flaw on the side of block representing the component O.D surface

- 2) One surface flaw on the side of block representing the component I.D surface
- 3) One Sub surface flaw

When the scan plan to be utilized subdivides a weld in to multiple examination zones, a minimum of one flaw per zone is required.

10.7 FLAW SIZE

Demonstration block flaw sizes shall be based on the demonstration block thickness and no longer than that specified by referencing code

- a) Maximum through height for material less than 25 mm thick.
- b) 0.25 aspect ratio acceptable flaw for material equal to or greater than 1 inch thick.

10.8 ONE SIDE EXAMINATION.

When the obstruction, the weld examination can only be performed from one side of the weld axis, the demonstration block shall contain two sets of flaws. One set on each side of the weld axis. When the demonstration block can be scanned from both side of the weld axis during the qualification scan, then only one set of flaw is required.

10.9 FLAW SIZING AND CATEGORY:

Flaw shall be sized and categorised in accordance with the written procedure being qualified.

10.10 AUTOMATIC AND SEMIAUTOMATIC ACCEPTANCE CRITERIA

Acceptable performance is define as the detection of all the flaws in the demonstration block and,

- 1) Recorded response or imaged length as exceeds the specified evaluation criteria
- 2) The flaw are sized as being equal to or greater than their actual size (i.e.. both length and height)
- 3) Flaw are properly categorized (i.e.. surface or sub surface)

10.11 SUPPLEMENTAL MANUAL TECHNIQUE(S) ACCEPTABLE PERFORMANCE

Supplemental manual technique is used to detect transverse indication only.

10.12 DEMONSTRATION BLOCK RECORDS

The following information shall be recorded:

- 1) The information specified by the procedure being qualified
- 2) Demonstration block thickness, joint geometry including any cladding or weld overlay, flaw data (i.e. position in block, size (length and height), separation distance to nearest surface and category (surface or sub-surface)
- 3) Scanning sensitivity and scanning travel speed

- 4) Qualification scans data
- 5) Flaw sizing data
- 6) Supplemental manual technique sizing data if applicable.

11.0 SCAN PLAN

Scan plan showing transducer position and movement, focal law, Type of transducer and frequency and component coverage that provide a standard and repeatable methodology for weld acceptance. The scan plan should also include probe and wedge details, ultrasonic beam angle to be used, beam direction concerning the centerline and weld material volume to be examined. The actual scan plan shall be qualified on the demonstration block mentioned in 10.0. (Refer to sample scan plan mentioned in attachment- D)

12.0 SURFACE PRAPARATION

The base metal on both sides of the weld shall be free of weld spatter, surface irregularities "OR" foreign materials that might interfere with the examination.

Where the weld surfaces interfere with the examination, the weld shall be prepared as needed to permit the examination.

13.0 SCANNING PROCEDURE OR EXAMINATION

The scanning shall include the volume of the weld and HAZ (i.e.25mm or t from each side of the weld toe). The contractor shall provide the drawings for the joint preparation and dimensions of the weld to be examined.

The data shall be collected with the Scanning speed as per demonstration.

Phased array data presentation shall be in A-scan, B-scan and C-scan and Height and length of the flaw shall be measured in B-scan or C scan.

Mechanical holder shall be used to ensure that probe spacing is maintained at a fixed distance. The mechanical holder shall also ensure that alignment to the intended scan axis on the examination piece is maintained. Probe motion may be achieved using motorizes or manual means and the mechanical holder for the probe shall be equipped with a positional encoder that is synchronized with the sampling of A-scans.

Manual shear wave scans shall be performed for searching transverse discontinuities or laminar discontinuities.

14.0 EVALUATION OR DATA ANALYSIS CRITERIA

The location of amplitude and extent of all reflectors that produce a response greater than 20 % of the reference level shall be investigated.

15.0 GEOMETRIC INDICATION

Ultrasonic indications of geometric and metallurgical origin shall be classified as follows:

- 15.1 Indication that are determined to originate from the surface configurations (such as weld reinforcement or root geometry) or variations in the metallurgical structure of materials (such as cladding to base material interface) may be classified as geometric indications, and

- 1) Need not be characterized or sized by (i) (3) Code Case 181

- 2) Need not be compared with allowable flaw size acceptance criteria of table 1 or 2 as given below
- 3) The maximum indication amplitude and location shall be recorded.

15.2 The following steps shall be taken to classify an indication as geometric :

- 1) Interpret the area containing the reflector in accordance with the applicable examination procedure.
- 2) Plot and verify the reflector coordinates provide a cross-sectional display showing the reflector position and surface discontinuity such as root or counterbore:
- 3) Review fabrication or weld prep drawings.

15.3 Alternatively, other NDE methods may be applied to classify an indication as geometric (e.g., alternative UT beam angles, radiography). The method employed is for information only to classify the indication as geometric and ASME B 31.3 requirements for examination techniques are only required to the extent that they are applicable.

16.0 FLAW SIZING

16.1 The dimensions of the flaw shall be determined by the rectangle that fully contains the area of the flaw (see below figure).

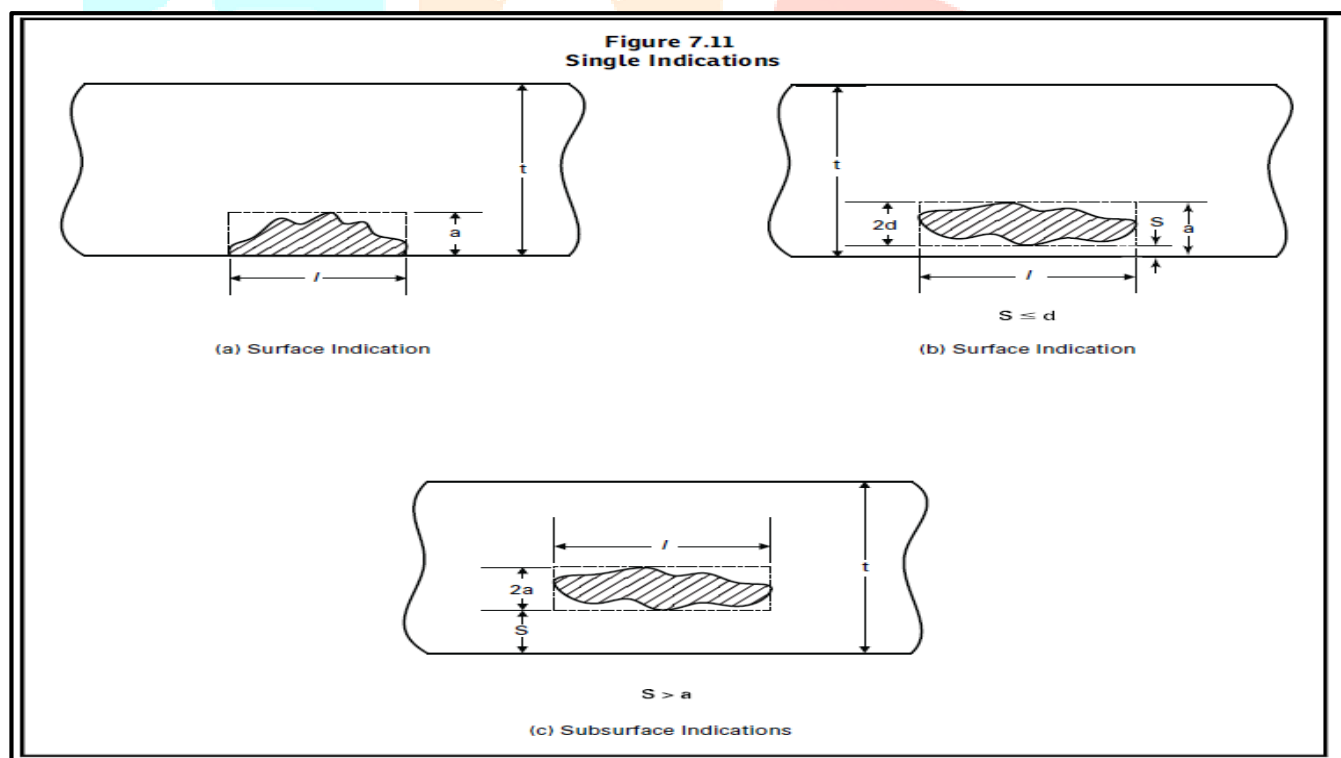

Figure -1

- a) The length (l) of the flaw shall be drawn parallel to the inside pressure-retaining surface of the component.
- b) The depth of the flaw shall be drawn normal to the inside pressure retaining surface and shall be denoted as "a" for a surface flaw or "2a" for a subsurface flaw.

Figure 7.12
Multiple Planar Flaws Oriented in a Plane Normal to the Pressure Retaining Surface

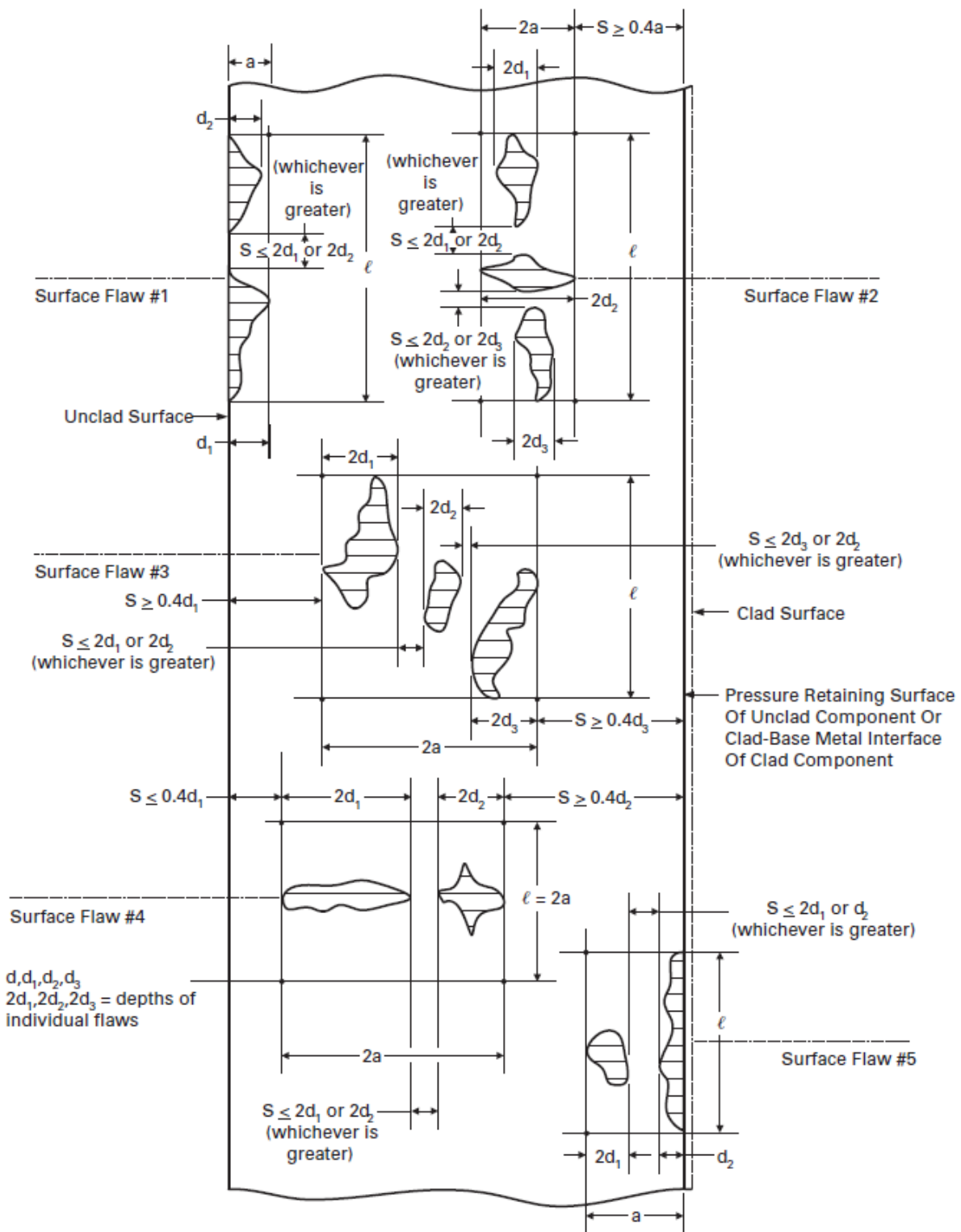

Figure -2

Figure 7.13
Surface and Subsurface Flaws

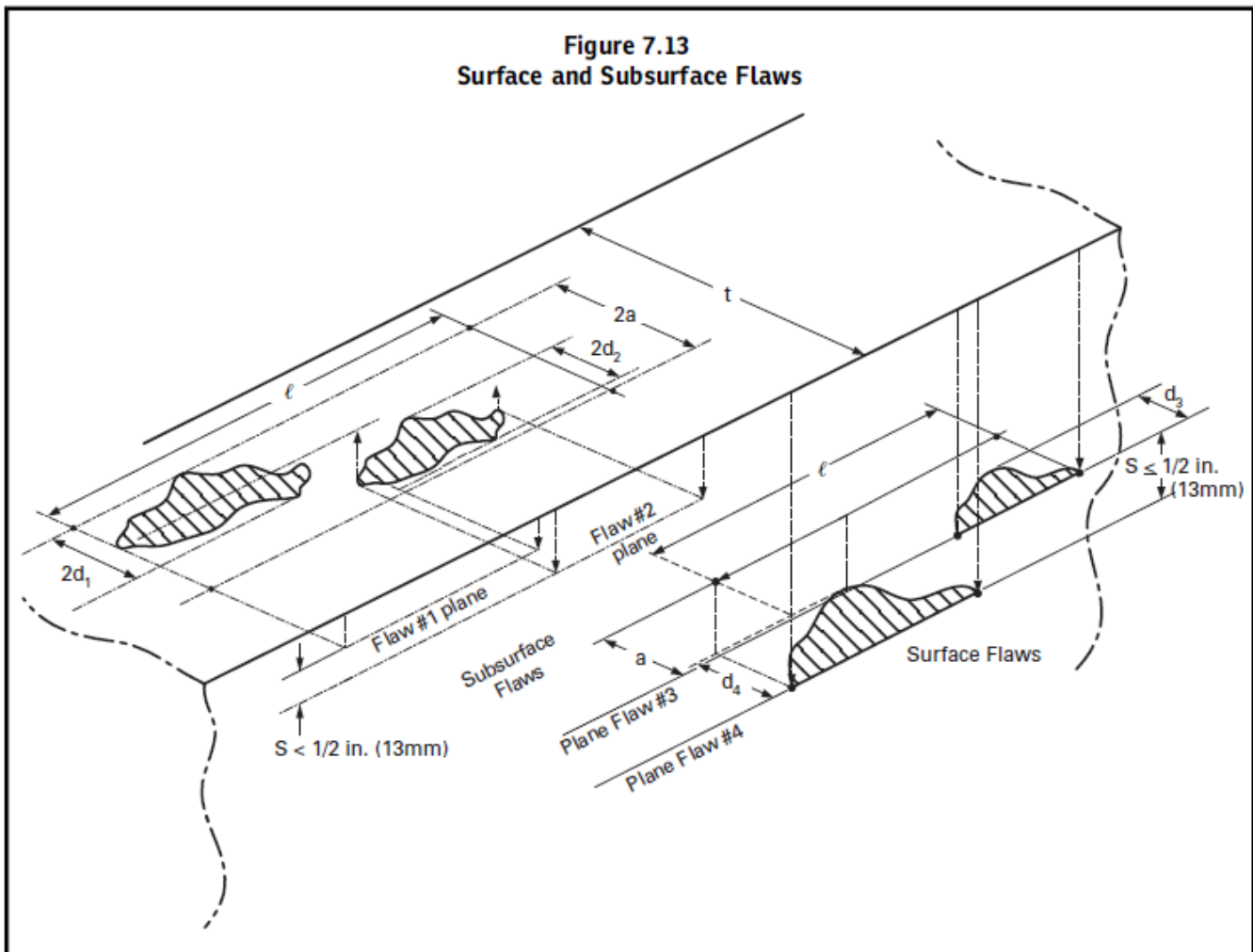
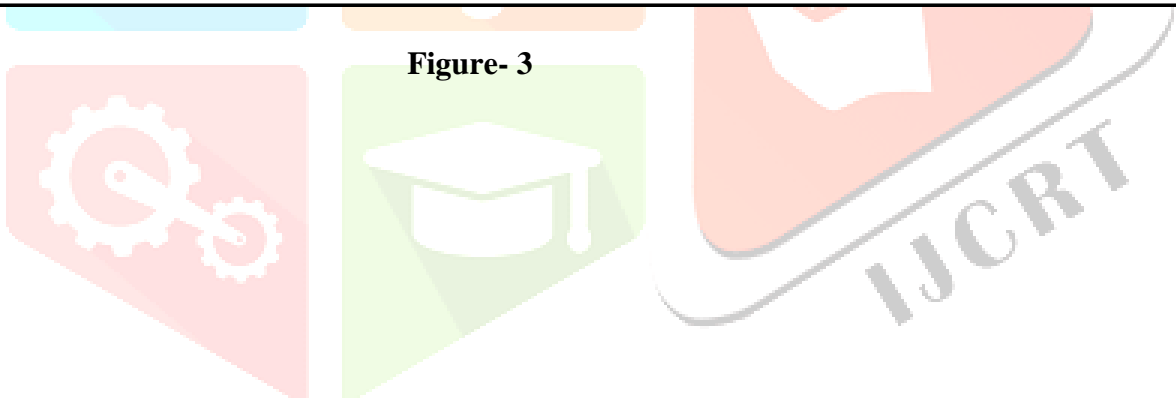

Figure- 3



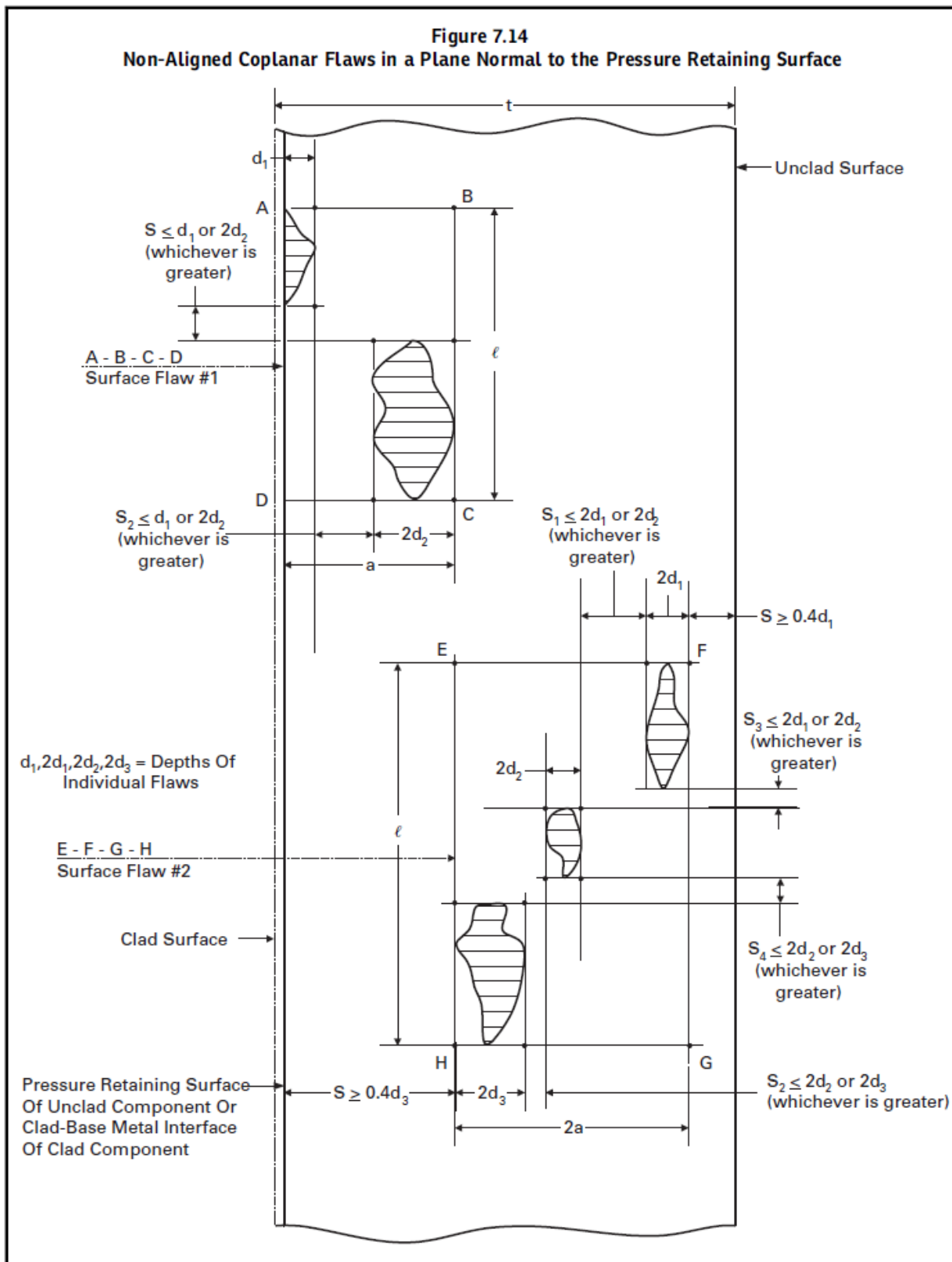
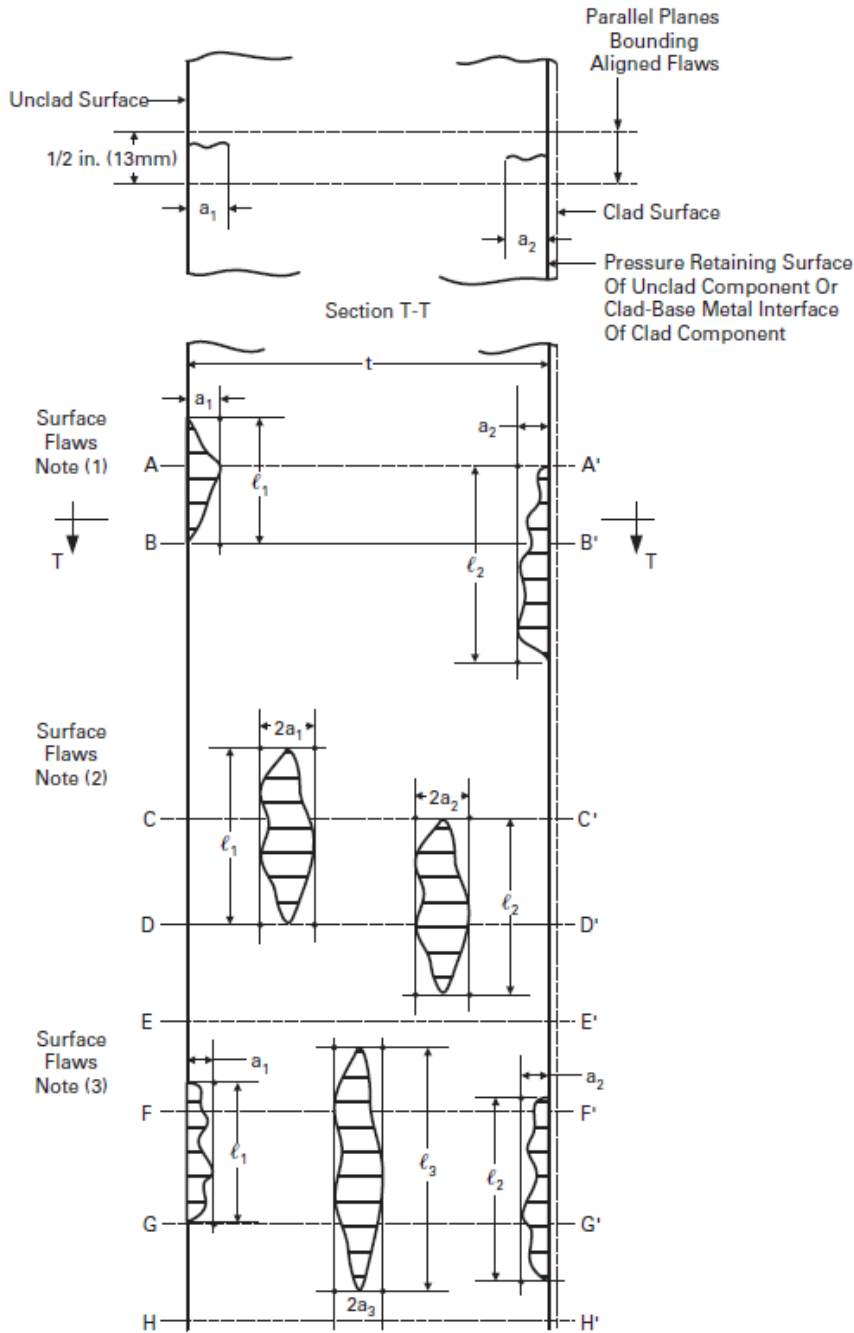

Figure 7.15
Multiple Aligned Planar Flaws



NOTES:

- (1) This illustration indicates two surface flaws. The first, a_1 , is on the outer surface, and the second, a_2 , is on the inner surface:
 $(a_1 + a_2) \leq (a_s + a_s^*)/2$ within planes A - A' and B - B'
- (2) This illustration indicates two subsurface flaws: $(a_1 + a_2) \leq (a_e + a_e^*)/2$ within planes C - C' and D - D'
- (3) This illustration indicates two surface flaws and one subsurface flaw.

Figure- 5

17.0 FLAW EVALUATION AND ACCEPTANCE CRITERIA

Flaws shall be evaluated for acceptance using the applicable criteria of Tables 7.8, 7.9 or 7.10, and with the following additional requirements. Unacceptable flaws shall be repaired and the repaired welds shall be reevaluated for acceptance. Refer to Acceptance criteria table 1,2 and 3 attached here with.

17.1 SURFACE FLAWS

Flaws identified as surface flaws during the UT examination may or may not be surface-connected. Therefore, unless the UT data analysis confirms that the flaw is not surface-connected, it shall be considered surface-connected or a flaw open to the surface, and is unacceptable unless surface examination is performed. If the flaw is surface-connected, the requirements above still apply. However, in no case shall the flaw exceed the acceptance criteria in this Division for the material employed.

Acceptance surface examination techniques are as follows:

- 1) Magnetic particle examination (MT) in accordance with applicable code
- 2) Liquid penetrant examination (PT) in accordance with applicable code
- 3) Eddy Current examination (ET) in accordance with applicable code

17.2 MULTIPLE FLAWS

- 1) Discontinuous flaws shall be considered a singular planar flaw if the distance between adjacent flaws is equal to or less than the dimension S as shown in Figure 2.
- 2) Discontinuous flaws that are oriented primarily in parallel planes shall be considered a singular planar flaw if the distance between the adjacent planes is equal to or less than 13 mm (1/2 in) (see Figure 3).
- 3) Discontinuous flaws that are coplanar and nonaligned in the through-wall thickness direction of the component shall be considered a singular planar flaw if the distance between adjacent flaws is equal to or less than S as shown in Figure 4.
- 4) Discontinuous flaws that are coplanar in the through-wall direction within two parallel planes 13 mm (1/2 in) apart (i.e., normal to the pressure-retaining surface of the component) are unacceptable if the additive flaw depth dimension of the flaws exceeds those shown in Figure 5.

17.3 SUBSURFACE FLAWS

Flaw which are not consider as Surface flaw or multiple flaw, those flaws shall be consider as subsurface flaw. This flaw shall be evaluated for acceptance using the applicable criteria of Tables 7.8, 7.9 or 7.10. In addition to this if any discontinuity having length (l) greater than 4 times of thickness, shall not Acceptable.

18.0 REPORT

Automatic Computer enhanced data acquisition shall be used to obtain permeant record of full weld to demonstrate the absence, or not, of linear type discontinuities with amplitudes exceeds the reference level. Report shall include below mention detail.

- 1) Procedure Identification and revision
- 2) Equipment Identification and detail
- 3) Search unit Details
- 4) Search unit cable(s) used , type and length
- 5) Beam angle used
- 6) Couplant used
- 7) Calibration and Qualification Block details
- 8) Computerized program identification and revision when used.
- 9) Reference Gain and scanning Gain

- 10) Weld Identification and thickness
- 11) Weld Volume coverage
- 12) Examination Surface
- 13) Record of rejected Indication
- 14) Restricted Area details
- 15) Special equipment when used (search unit, wedge, shoe, automatic scanning equipment, recording equipment ...et)
- 16) Instrument reference level gain and , if used, damping and reject setting
- 17) Calibration scan data & Report to be Submitted
- 18) Identification and location of weld or volume scanned
- 19) Surface from which examination was conducted including surface condition
- 20) Examination personal identification
- 21) Flaw height
- 22) The final data processing level
- 23) Search unit element size, number, pitch and Gap dimension
- 24) Focal law parameter, including as applicable ,angle or angular range, focal depth and plane, element numbered used, angular or element incremental change, and start and stop number or start element number
- 25) Wedge natural refracted angle
- 26) Scan plan (Scan plan and Report to be Submitted)
- 27) Supplemental manual technique(s) indication data
- 28) Scanner and adhering and guiding mechanism.

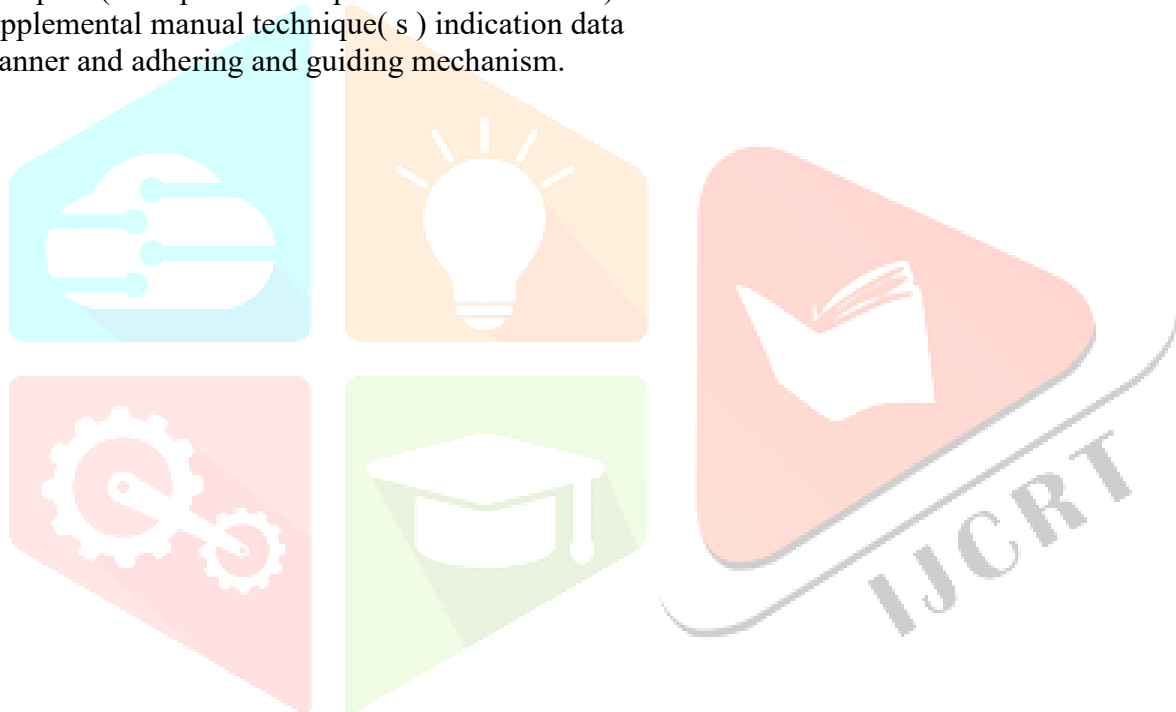

RESULT

Testing And Allied Services

F-170 Jai Shree Vihar, Kaithoon Road, Kota-324003

Tel.: 0744-2207221, Mob.: +91-9887965223, E-Mail: testingandallied@gmail.com

TOFD ULTRASONIC INSPECTION REPORT

Client:	TAS		Report No.	TAS/REPORT/2024 Rev.0							
Reference Procedure	Methodology		Date	10 February 2024							
Acceptance Standard	ASME SEC VIII Div.1 UW-53		Performed by	Madhur Sharma							
Examination System	TOFD		Equipment Type/Model/SI.No	Omniscan MX-2-QC-003241							
Total Weld length	6060 mm		Search Unit Model /SI.No.	10 MHz , 6 mm dia /SN-778198 & 778199							
Couplant	Wall paper paste + water		Material Type & Thickness	SA 516 Gr.70N / 14 mm							
Software used/version	Tomoview 2.9R13		Calibration Block Used	14 mm (2.5 mm Ø SDH)							
PWHT	Before –	After – YES	<u>Inspection Surface/Condition</u>	As welded / Satisfactory							
Results and Observations: -		Accept	Search Unit cable type/Length	Mini Lemo to Microdot Cable /3 m							
Weld Ident.	Total Length Scanned	Indication No:	X-value	Defect Size in mm						Welder No.	Assessment
				l	d	a	a/l	a/t	criteria		
CS-2 ASR	0-1000									AJ 2081 AJ 1960 AJ 963 AJ 0825	Accept
	1000-1150										
	1350-1700										
	1850-2000										
	2000-4500										
	4500-6100										

	=5750								
Legend: 'l'- Length of the indication , 'd'- Depth of Indication , 'a'- Height of the Indication ,									
Channels and Transducers settings Parallel Scan:- 70°- 10 MHz- 6mm Dia. – 10.00 dB – PCS 70 mm Non Parallel Scan:- 70°- 10 MHz- 6mm Dia. – 11.00 dB – PCS 50 mm Data sampling Spacing: 1mm All dimension in “ mm “ and outer surface from plate					Note: 1) Refer phased array report for TOFD blind Zones 2) Refer MUT report for TOFD transverse blind zones and laminar indication in TOFD/PA covered area 3) TOFD & PAUT scanning restricted from 1150 to 1350 & 1700-1850 Because of Foaling Area.				

-: WE RENDER :-

Non-Destructive Testings, Training and Certification of NDT Personnel, Level III Consultancy Services,
Supply and Manufacturing of Engineering Items.

Testing And Allied Services

F-170 Jai Shree Vihar, Kaithoon Road, Kota-324003

Tel.: 0744-2207221, Mob.: +91-9887965223, E-Mail: testingandallied@gmail.com

PHASED ARRAY - ULTRASONIC EXAMINATION REPORT

Client:	TAS		Report No.	TAS/REPORT/2024 Rev.0
Reference Procedure	Methodology		Date	10 February 2024
Acceptance Standard	ASME SEC VIII Div.1 UW-53		Performed by	Madhur Sharma
Examination System	Phased array		Equipment Type	Omniscan MX-2-QC-003241
Total Weld length	6060 mm		Search Unit	5L60-60x10-SA14 & SA14 N55S IHC
Couplant	Water + paper paste		Material Type & Thickness	SA 516 Gr.70N / 14 mm
Software used/version	Tomoview 2.1023		Calibration block	14 mm (2.5 mm Ø SDH)
Project / Contract No.	AL-ZOUR Refinery Project		Cable type/Length	PA CABLE /5 meters
PWHT	Before –	After – YES	Scanning surface/surface condition	outside/As Welded
Scanning Details	Contact linear Encoded		Reference Reflector	2.5 mm SDH
Reference sensitivity: Scan-1-32.0 dB, Scan-2-26.0dB, Scan-3-32.0 dB, Scan-4-26.0dB	Transfer correction: 0.0 dB		Scanning dB : +6 dB	

Scan	Probe	Wedge	Type of scan	Angular range	Skip distance	Group of elements	Starting element	Ending element	Step of increment	Focal depth	
Scan-1 & 3	5L60 (Total Element: 60 Elevation: 60mm Pitch: 1 mm)	SA14-N5S-IHC	Sectorial	55°-70°	-15 mm & +15mm	16	45	60	1°	Un-focuss	
Scan- 2 & 4			Sectorial	45°-60°	-15 mm & +15mm	16	45	60	1°		
Weld Ident.	Total weld scan length	Indi. No	Indication Size in mm							Welder No.	Result
			X value	l	d	a	a/l	a/t	Criteria		
CS-2 ASR	0-1000	-	-	-	-	-	-	-	-	AJ 2081 AJ 1960 AJ 963 AJ 0825	Accept
	1000-1150										
	1150-1350										
	1350-1700										
	1700-1850										
	1850-2000										
	2000-4500										
	4500-6100										
	=5750										

'l'- Length of the discontinuity, 'd'- Depth of the discontinuity, 'a'- Height of the discontinuity
Remarks: 1) PA was performed to cover TOFD blind zones 2) scanning was carried outer surface of plate
 3) All data in " mm " unless mention.

-: WE RENDER :-

Non-Destructive Testings, Training and Certification of NDT Personnel, Level III Consultancy Services, Supply and Manufacturing of Engineering Items.

OBSERVATION

Based on the provided scope and results from the two samples, here are some observations:

- ~~Scope and Procedure: The procedure outlines the use of Time-Of-Flight Diffraction (TOFD) as the main technique for weld inspection, supplemented by phased array ultrasonic testing (PAUT) to cover TOFD blind zones and manual ultrasonic testing (MUT) for detecting transverse and laminar discontinuities. The scope specifies the inspection of ferrous plate and piping butt weld joints, particularly focusing on carbon steel and low-temperature carbon steel (LTCS) materials with certain geometrical requirements.~~
- **Equipment and Calibration:** Equipment used includes the Omniscan MX-2 for TOFD examination and Tomoview 2.9R13 software for analysis. Calibration blocks are utilized to ensure accurate measurements. The examination system includes TOFD with specific search unit models, and the acceptance standard adheres to ASME SEC VIII Div. 1 UW-53.
- **Scanning Parameters:** Scanning parameters vary based on the specific requirements of the weld joints, including skew angle, wedge type, scan type, angular range, skip distance, group of elements, starting element, focal depth (FD), angle increment, and dB settings. Both parallel and non-parallel scans are employed, with detailed specifications for each.

- **Results and Acceptance:** Indications are recorded with their respective dimensions (length, depth, height), and assessments are made based on predefined criteria. Acceptance criteria are derived from ASME standards. Results indicate the acceptance or rejection of welds based on the observed indications.
- **Special Considerations and Restrictions:** Certain areas are restricted from scanning due to specific reasons, such as foaling areas, which require careful consideration during the inspection process.
- **Documentation and Reporting:** The document emphasizes the need to refer to phased array and manual ultrasonic testing reports for blind zones and additional indications not covered by TOFD or PAUT. Proper documentation of results and any deviations from the standard procedure is crucial for traceability and compliance.

Overall, the observations suggest a comprehensive inspection procedure compliant with ASME standards, utilizing advanced ultrasonic testing techniques tailored to the specific requirements of the weld joints being examined.

DISCUSSION AND CONCLUSION

Based on the provided scope and results from the two samples, we can draw the following discussion and conclusions:

- **Scope Coverage:** The procedure outlined encompasses guidelines from ASME Sec. VIII Div. 1, ASME Sec. VIII Div. 2, and ASME B31.3, focusing on weld inspection of ferrous Plate and piping butt weld joints. It utilizes TOFD as the primary technique, supplemented by phased array and Manual UT for comprehensive inspection.
- **Relevance to Weld Geometry and Material:** The procedure is applicable to single or double V-shaped weld joints with a material thickness of 25mm and above and pipe diameter of 6" and above. It's important to note that complex geometries and alternative materials may require special considerations, implying adaptability to diverse scenarios.
- **Sample 1 Evaluation:** Sample 1 presents findings from a pipe-to-elbow weld joint. The measurements indicate various indications, primarily sub-surface, with assessment outcomes varying from acceptance to rejection based on specified criteria. Notably, the measured thickness on the pipe falls within the specified range.
- **Sample 2 Evaluation:** Sample 2 details inspection results using TOFD for a total weld length of 6060 mm. Acceptable indications are reported with a clear breakdown of weld segments, their corresponding assessment outcomes, and associated defect sizes. The equipment specifications and inspection parameters align with the outlined procedure.
- **Equipment and Settings:** Both samples provide insights into the equipment used, including examination systems, transducer models, calibration blocks, and software versions. Detailed settings for parallel and non-parallel scans are provided, along with data sampling spacing.
- **Restriction Zones and Considerations:** Both samples highlight restricted scanning areas due to foaling areas, demonstrating adherence to safety and practical considerations. Additionally, references are made to phase array and manual UT reports for blind zones and laminar indications, showcasing a comprehensive inspection approach.

CONCLUSION

- The procedure outlined in the document demonstrates a comprehensive approach to weld inspection, incorporating advanced techniques such as TOFD and PAUT alongside traditional methods like Manual UT.

- Results from Sample 1 and Sample 2 showcase the effectiveness of the inspection procedure in identifying and assessing indications, thereby ensuring the integrity of weld joints.
- Adherence to industry standards and meticulous attention to detail underscore the reliability and quality of the inspection process.
- Recommendations for further improvement may include continuous training on the utilization of advanced inspection techniques and periodic review of inspection procedures to incorporate any updates in relevant codes and standards.

In summary, the provided scope and results indicate a robust weld inspection procedure that aligns with industry standards, ensuring the integrity and reliability of weld joints in ferrous Plate and piping applications.



ATTACHMENT- A
DEMONSTRATION BLOCK SKETCH

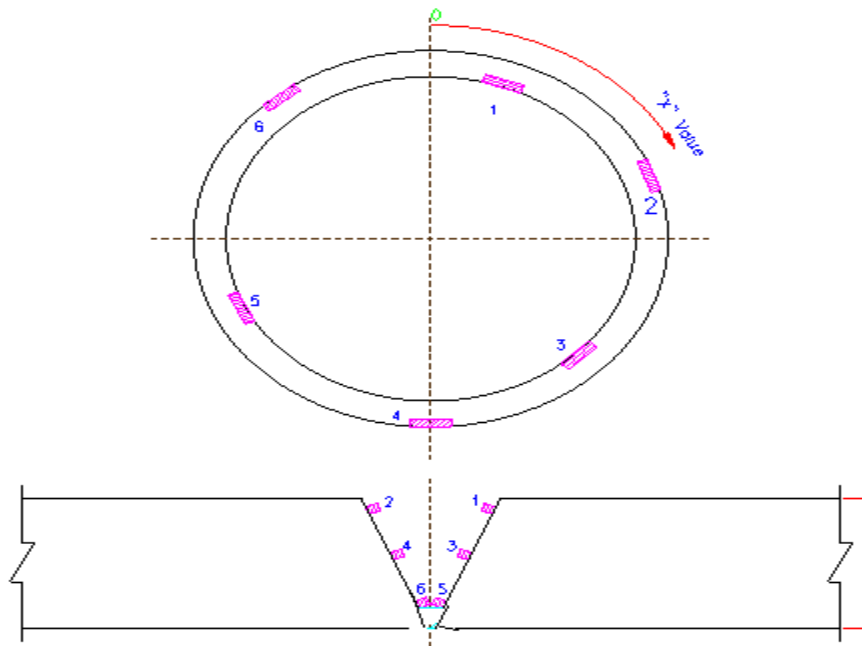

DEMONSTRATION BLOCK FLAW DIMENSION FOR 30.96MM THICKNESS

Sr. No	X-Value (mm)	Depth (mm)	Length (mm)	Height (mm)
1	200	2	10	1.5
2	500	2	10	1.5
3	800	15	20	2
4	1100	15	20	2
5	1300	28	10	1.5
6	1600	28	10	1.5

Note :

- 1) Pipe / Plate block material shall be from same material as production weld
- 2) Weld Configuration shall be same as production weld
- 3) Same welding process shall be same as production weld
- 4) Flaws shall be induce naturally or by EDM process

ATTACHMENT - B

BASIC CALIBRATION BLOCK FOR PAUT

(DIA. GREATER THAN 500mm)

(As per ASME Sec.V article 4 clause 434.2: Non-piping calibration block)

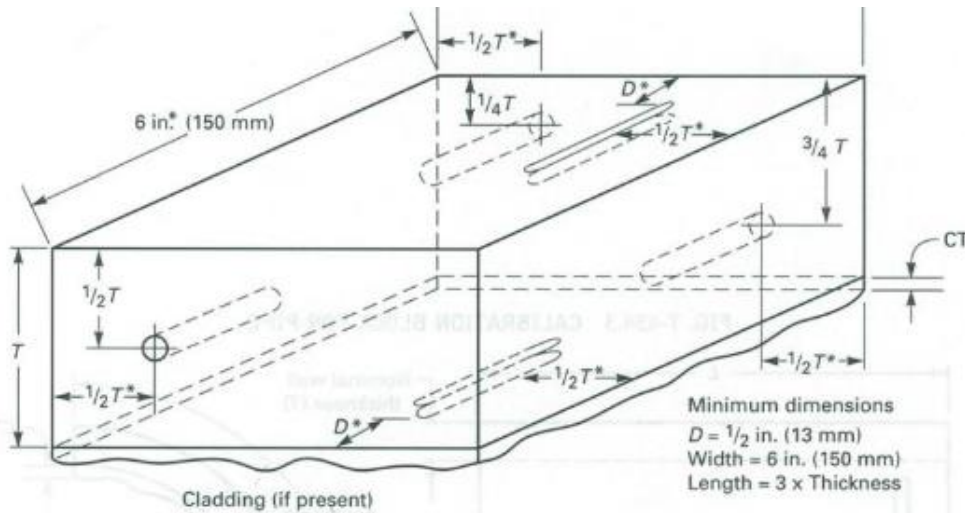

Weld Thickness, t , in. (mm)	Calibration Block Thickness, T , in. (mm)	Hole Diameter, in. (mm)	Notch Dimensions, in. (mm)
Up to 1 (25)	$\frac{3}{4}$ (19) or t	$\frac{3}{32}$ (2.5)	Notch depth = $2\% T$
Over 1 (25) through 2 (50)	$1\frac{1}{2}$ (38) or t	$\frac{1}{8}$ (3)	Notch width = $\frac{1}{4}$ (6) max.
Over 2 (50) through 4 (100)	3 (75) or t	$\frac{3}{16}$ (5)	Notch length = 1 (25) min.
Over 4 (100)	$t \pm 1$ (25)	[Note (1)]	

GENERAL NOTES:

- (a) Holes shall be drilled and reamed 1.5 in. (38 mm) deep minimum, essentially parallel to the examination surface.
- (b) For components equal to or less than 20 in. (500 mm) in diameter, calibration block diameter shall meet the requirements of T-434.1.7.2. Two sets of calibration reflectors (holes, notches) oriented 90 deg from each other shall be used. Alternatively, two curved calibration blocks may be used.
- (c) The tolerance for hole diameter shall be $\pm \frac{1}{32}$ in. (0.8 mm). The tolerance for hole location through the calibration block thickness (i.e., distance from the examination surface) shall be $\pm \frac{1}{8}$ in. (3 mm).
- (d) For blocks less than $\frac{3}{4}$ in. (19 mm) in thickness, only the $\frac{1}{2} T$ side-drilled hole and surface notches are required.
- (e) All holes may be located on the same face (side) of the calibration block, provided care is exercised to locate all the reflectors (holes, notches) to prevent one reflector from affecting the indication from another reflector during calibration. Notches may also be in the same plane as the in-line holes (See Appendix J, Fig. J-431). As in Fig. J-431, a sufficient number of holes shall be provided for both angle and straight beam calibrations at the $\frac{1}{4} T$, $\frac{1}{2} T$, and $\frac{3}{4} T$ depths.
- (f) Notch depths shall be $1.6\% T$ minimum to $2.2\% T$ maximum. When cladding is present, notch depth on the cladding side of the block shall be increased by the cladding thickness, CT (i.e., $1.6\% T + CT$ minimum to $2.2\% T + CT$ maximum).
- (g) Maximum notch width is not critical. Notches may be made by EDM or with end mills up to $\frac{1}{4}$ in. (6.4 mm) in diameter.
- (h) Weld thickness, t is the nominal material thickness for welds without reinforcement or, for welds with reinforcement, the nominal material thickness plus the estimated weld reinforcement not to exceed the maximum permitted by the referencing Code Section. When two or more base material thicknesses are involved, the calibration block thickness, T , shall be determined by the average thickness of the weld; alternatively, a calibration block based on the greater base material thickness may be used provided the reference reflector size is based upon the average weld thickness.

NOTE:

- (1) For each increase in weld thickness of 2 in. (50 mm) or fraction thereof over 4 in. (100 mm), the hole diameter shall increase $\frac{1}{16}$ in. (1.5 mm).

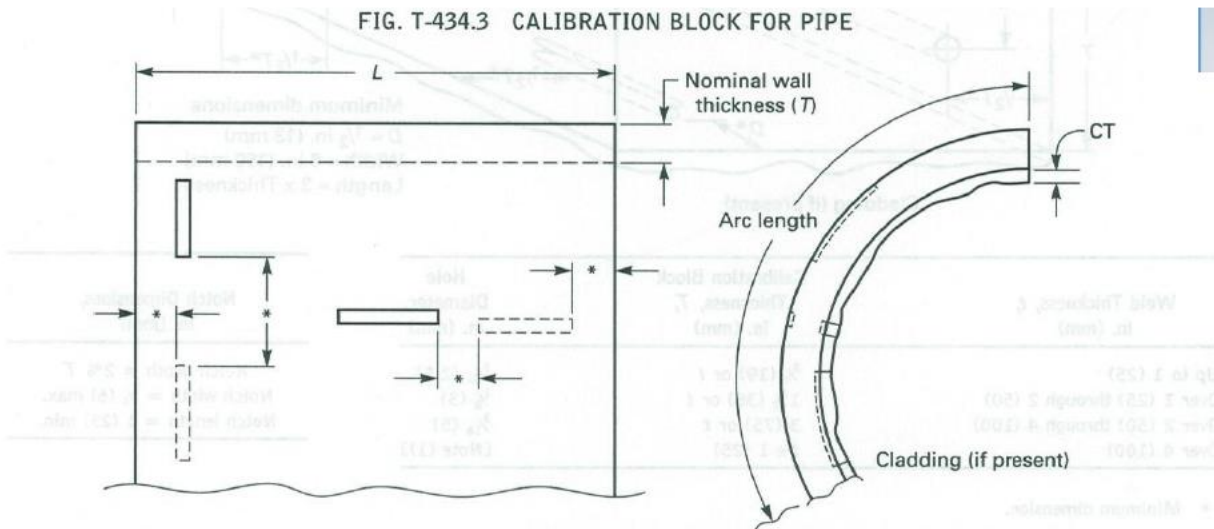
ATTACHMENT - C**BASIC CALIBRATION BLOCK FOR PAUT****(DIA. 500MM AND LESS)**

* Notches shall be located not closer than T or 1 in. (25 mm), whichever is greater, to any block edge or to other notches.

GENERAL NOTES:

- The minimum calibration block length (L) shall be 8 in. (200 mm) or $8T$, whichever is greater.
- For OD 4 in. (100 mm) or less, the minimum arc length shall be 270 deg. For OD greater than 4 in. (100 mm), the minimum arc length shall be 8 in. (200 mm) or $3T$, whichever is greater.
- Notch depths shall be 8% T minimum to 11% T maximum. When cladding is present, notch depths on the cladding side of the block shall be increased by the cladding thickness, CT (i.e., 8% T + CT minimum to 11% T + CT maximum). Notch widths shall be $\frac{1}{4}$ in. (6 mm) maximum. Notch lengths shall be 1 in. (25 mm) minimum.
- Maximum notch width is not critical. Notches may be made with EDM or with end mills up to $\frac{1}{4}$ in. (6 mm) in diameter.
- Notch lengths shall be sufficient to provide for calibration with a minimum 3 to 1 signal-to-noise ratio.

