



## Antacid Bilayer Tablet formulation

( rabeprazole and domperidone)

Prof.Parbhane M.B., Bhosale Tanaji Tulshiram, Raut Viraj Vivek ,Lande Shivam Tanaji. Sitabai Thite Collage Of Pharmacy

### Abstract :

An antacid bilayer tablet containing rabeprazole and domperidone could emphasize its innovative design for simultaneous relief of acidity and associated symptoms. This bilayered formulation integrates the proton pump inhibitor, rabeprazole, in one layer to target gastric acid secretion and the prokinetic agent, domperidone, in another layer to enhance gastrointestinal motility. This dual-layer configuration aims to optimize drug release profiles, ensuring coordinated and sustained therapeutic effects. The antacid bilayer tablet offers a potential solution for improved efficacy and patient compliance in managing acid-related disorders by addressing multiple aspects of the underlying pathology. Efficacy, safety, and the unique pharmaceutical attributes of this bilayer tablet warrant further investigation for its clinical applicability.

### Key words :

Bilayer synergistic effect, Rbeprazole and domperidone, efficacy, gastrointestinal Motility ,therapeutic effect sustained release,

### Introduction:

The introduction for a bilayer tablet could emphasize the evolving landscape of pharmaceutical formulations and the increasing demand for innovative drug delivery systems. Bilayer tablets represent a notable advancement in this context, offering a duallayered structure that enables the simultaneous release of two distinct drug components. This design is particularly advantageous for combining drugs with complementary therapeutic effects or those requiring different release profiles. The introduction may further explore the rationale behind bilayer tablets, discussing their potential benefits in terms of improved efficacy, optimized treatment regimens, and enhanced patient compliance. By providing a platform for controlled release and tailored drug delivery, bilayer tablets contribute to the diversification of pharmaceutical options, addressing specific challenges in drug administration and patient care.

An antacid tablet formulation could start by acknowledging the widespread prevalence of acid-related gastrointestinal disorders and the need for effective and versatile treatment options. It would highlight the significance of antacid formulations in providing relief from symptoms such as heartburn, regurgitation, and indigestion, which significantly impact the quality of life for many individuals. The introduction may further delve into the various classes of drugs commonly used in antacid formulations,

emphasizing the importance of balancing acid reduction with addressing motility issues. Additionally, it could touch upon the challenges associated with existing formulations and introduce the rationale behind developing a novel antacid tablet formulation, setting the stage for discussions on its specific components, mechanism of action, and potential advantages in clinical applications.

The antacid bilayer tablet formulation of rabeprazole and domperidone could begin by emphasizing the significance of addressing both gastric acid secretion and associated motility issues in the management of acid-related disorders. This innovative bilayer tablet aims to provide a comprehensive solution by incorporating rabeprazole, a potent proton pump inhibitor targeting acid production, and domperidone, a prokinetic agent enhancing gastrointestinal motility. The dual-layer structure of the tablet is designed to optimize drug release kinetics, ensuring synchronized therapeutic benefits. This introduction sets the stage for discussing the rationale behind the formulation, highlighting the potential advantages in terms of efficacy, patient compliance, and overall treatment outcomes for individuals experiencing acid-related gastrointestinal conditions.

Rabeprazole is generally considered a highly soluble compound. Its solubility is influenced by factors such as temperature and pH. In aqueous solutions, rabeprazole dissolves readily. It is important to note that the solubility of rabeprazole sodium, the salt form commonly used in pharmaceuticals, is particularly high.

Domperidone is known to be practically insoluble in water. Its solubility is pH-dependent, and it exhibits increased solubility in acidic environments. Domperidone is often administered orally, and its absorption can be influenced by factors such as gastric pH.

#### PLAN OF WORK

- 1) Literature survey
- 2) Selection of suitable polymers.
- 3) Selection of suitable excipients.
- 4) Analysis of drug, polymer & excipients interaction.
- 5) Preparation of antacid bilayer tablet.
- 6) Evaluation of it
- 8) Application of statistical treatment to data obtained.
- 9) Application of kinetic treatment to data obtained.
- 10) Comparison of result obtained from dissolution studies.

Aim and Objective:

Aim:

The main of present work is to devlope and evaluate bilayer tablet containg compressed Multiparticulate rapid release rabeprazole layer and dompridone sustained release layer.

Objective:

- 1.The main objective of the present work is to develop antacid bilayer tablet by using rabeprazole and Domperidone.
2. To achieve FDC in simplest manner of Drug Delivery System.
- 3.To prepare Bilayer tablets by using compressible granules of rabeprazole and sustained release granules of Domperidone.
4. To evaluate the resistance to rupture of different enteric coating polymers to compression force.
- 5.To maintain the drug concentration in blood for a longer time.
- 6.To study the stability of dosage form and compare with the standard specifications.

Drug Profile :

Name: Rabeprazole

Class: proton pump inhibitor

1.Mechanism of action:

Rabeprazole works by inhibiting the proton pumps in the stomach. These pumps are responsible for producing stomach acid, which can lead to acidic reflux and heartburn. By inhibiting these pumps, rabeprazole reduces the amount of acid that is produced, thereby providing relief to the patient.

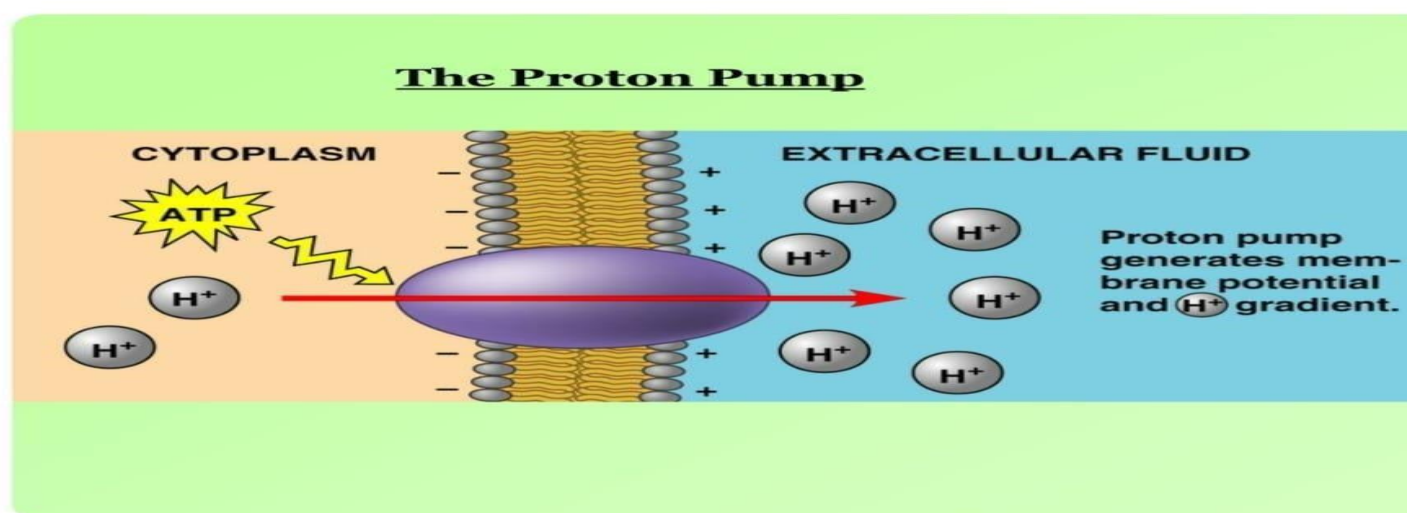

Bioavailability- 52%

Protein binding- 96.3%

Metabolism- CYP2C19 and CYP3A4 in the liver

Metabolites- thioether carboxylic acid metabolite, thioether glucuronide metabolite, sulfone metabolite

Elimination half-life-1 hour

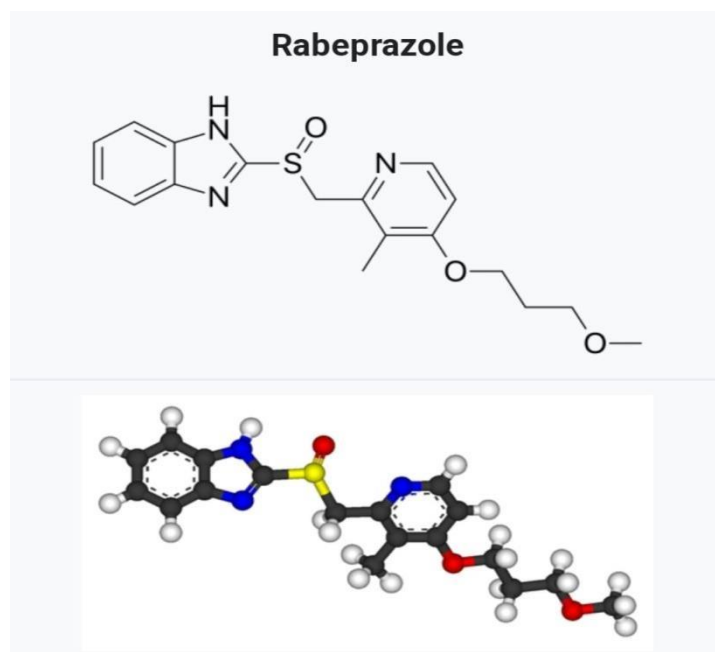

Excretion- 90% via kidney as metabolites

IUPAC name-(RS)-2-([4-(3-Methoxypropoxy)-3-methylpyridin-2-yl]methylsulfinyl)-1Hbenzo[d]imidazole

CAS Number-117976-89-3 check

PubChem CID5029

IUPHAR/BPS7290

DrugBank-DB01129 check

ChemSpider-4853 check

UNII-32828355LL

PDB ligand-RZX (PDBe, RCSB PDB)CompTox Dashboard (EPA)DTXSID3044122

ECHA InfoCard-100.123.408

Formula-C<sub>18</sub>H<sub>21</sub>N<sub>3</sub>O<sub>3</sub>S

Molar mass-359.44 g·mol<sup>-1</sup>

Drug interactions:

Rabeprazole may interact with certain medications, altering their efficacy or increasing the risk of adverse effects. It is important to consult with a healthcare professional before initiating any new treatments, especially these

1. Warfarin: Potential for increased bleeding risk.
2. Digoxin: Possible elevation of digoxin serum levels.
3. Methotrexate: Potential inhibition of methotrexate elimination, leading to increased toxicity.

Adverse Effects:

- Headache
- Diarrhea
- Nausea
- Abdominal pain

Conclusion:

Rabeprazole is an effective antacid medication that is commonly prescribed for GERD, peptic ulcers, and Zollinger-Ellison syndrome. It works by reducing the production of stomach acid, thus providing relief to patients. While it may interact with other medications, rabeprazole is generally safe for use when taken exactly as prescribed.

Name: domperidone

Class: Dopamine Antagonist

Mechanism Of Action:

The DA<sub>2</sub>-receptor antagonist domperidone antagonizes the inhibitory effect of dopamine, resulting in stimulation of gastric muscle contraction. This provides a mechanism for the gastrokinetic effect of domperidone.

### Graphical Abstract

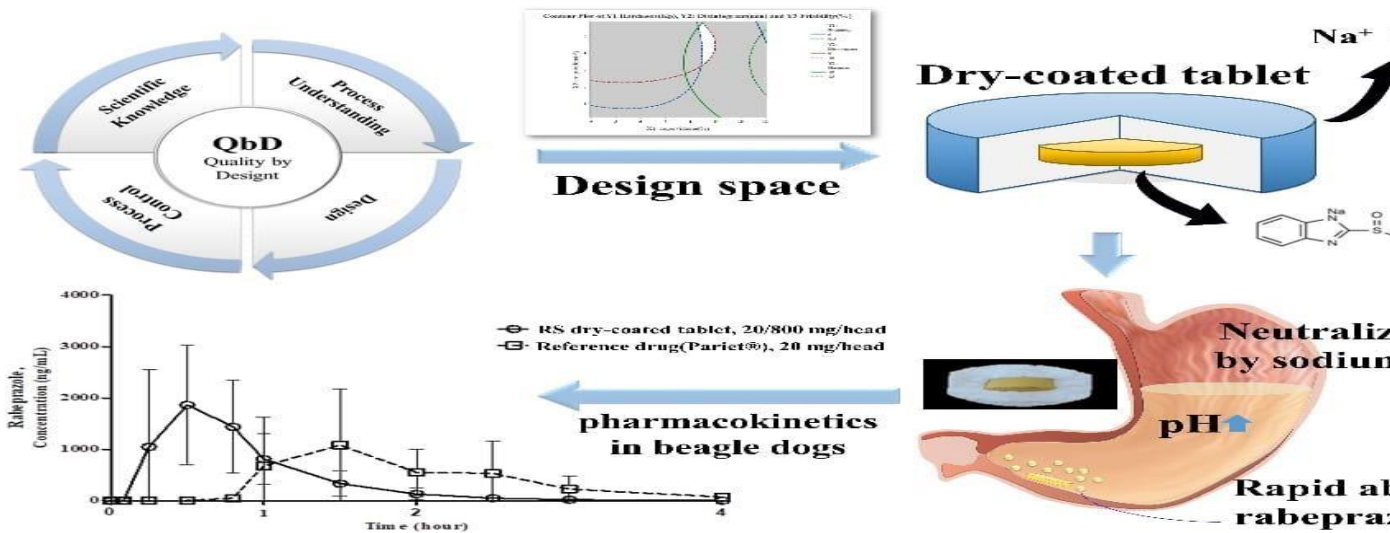

Bioavailability-Oral-13-17%

Intramuscular: 90%

Protein binding-92%

Metabolism Hepatic- (CYP3A4/5) and intestinal (first-pass)

Onset of action-30-60 minutes

Elimination half-life 7-9 hours

Excretion Feces: 66%, Urine: 32% Breast milk: small quantities

Formula- C<sub>22</sub>H<sub>24</sub>ClN<sub>5</sub>O<sub>2</sub>

Molar mass- 425.92 g·mol<sup>-1</sup>

IUPAC name- 5-Chloro-1-(1-[3-(2-oxo-2,3-dihydro-1H-benzo[d]imidazol-1-yl)propyl]piperidin-4-yl)-1H-benzo[d]imidazol-2(3H)-one

CAS Number- 57808-66-9 check

### Domperidone

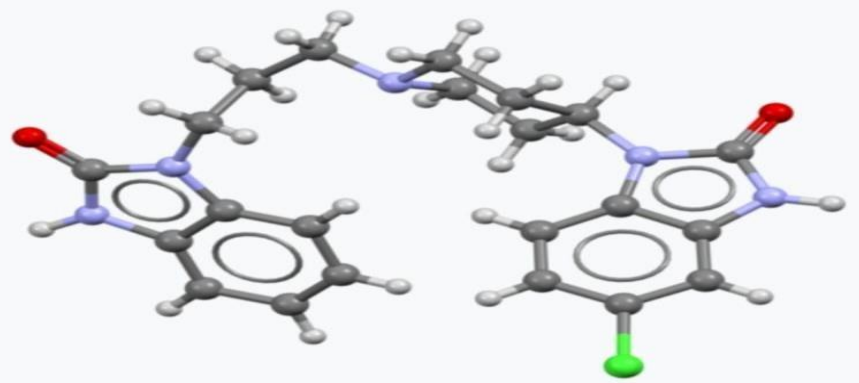
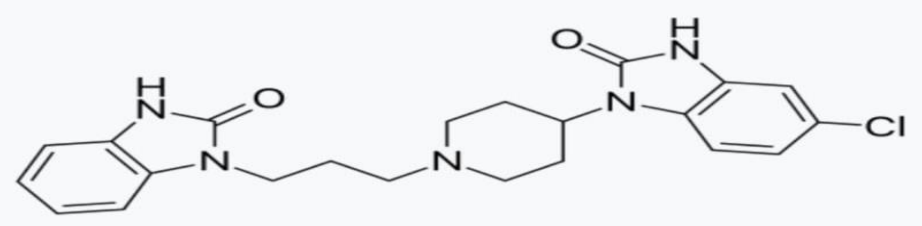

PubChem CID-3151

IUPHAR/BPS-965

DrugBank-DB01184 check

ChemSpider-3039 check

UNII5587267Z69

KEGG-D01745

ECHA InfoCard-100.055.408

Drug interaction:

Domperidone can potentially interact with other medications, affecting their efficacy or increasing the risk of side effects. It is important to inform your healthcare provider about all medications, including over-the-counter and herbal supplements, that you are taking to avoid potential drug interactions.

Adverse Effects:

1. Gastrointestinal effects (e.g., abdominal cramps, diarrhea)
2. Extrapyramidal effects (rare)
3. Breast tenderness and galactorrhea (rare)

Contraindications:

1. Hypersensitivity to domperidone
2. Prolactin-releasing pituitary tumors

Precautions:

Use caution in patients with hepatic impairment. Domperidone should be used at the lowest effective dose for the shortest duration necessary.

Solubility Enhancement Methods:

A.Physical Modification:

1.Particle Size Reduction :

The drug solubility depends on its particle size. Large particles provide a low surface area, which results in less interaction of particles with the solvent. One of the methods to increase the drug's surface area is to reduce its particle size, which improves its dissolution property.

### Micronization:

The process of producing drug particles in micron size by using the physical method. The methods widely used for increasing BCS class II drugs' solubility are freeze-drying, crystallization, spray drying, and milling. Size reduction in the conventional time is achieved through mechanical methods, i.e., grinding, milling, and crushing of heavier particles to reduce their size by applying friction, pressure, attrition, shearing or impact. For mechanical micronization, ball mills, jet mills and high-pressure homogenizers are utilized. Dry milling is the most preferred micronization method.

Micronization raises the dissolution speed rather than the drug's equilibrium solubility. In various studies, it has been reported these that methods for the reduction in size are used to increase the dissolution and bioavailability through decreasing dimension and increasing the surface area of poorly aqueously soluble drugs.

### Nanosuspension:

Nanosuspension is well-defined as a colloidal dispersion of sub-micron drug elements, stabilized by using a surfactant. To produce a nanosuspension, wet milling and homogenization are used. Milling defragments the active compound in the presence of a surfactant.

\*Advantages of nanosuspension

\*Enhancement of drug solubility and its bioavailability

\*Higher drug loading

\*Suitable for hydrophobic drugs

\*Passive drug targeting

\*Reduction in dosage

\*Increase in drug's physical and chemical stability.

### Methods for the Preparation of a Nanosuspension:

A nanosuspension is primed via two main methods—"bottom-up" and "top-down" technology .

**Bottom-up technology**—This is an assembling technique for the formation of nanoparticles, such as precipitation, melt emulsification, and microemulsion.

**Top-down technology**—Includes the decomposition of heavier particles into small particles, such as the high-pressure homogenization method and the grinding techniques.

### Microemulsion :

The nanosuspensions can be prepared simply by the dilution of the emulsion, which is molded through a partly miscible solvent with water according to a dispersed phase. This method is suitable for drugs soluble in volatile organic solvents or partially miscible in water. In addition to that, microemulsion templates can also be used to create nanosuspensions.

Physically, a microemulsion comprises a dispersion of oil and water and stabilizer (cosurfactant or surfactant) fluids, which are immiscible. The drug molecules are introduced in the internal phase, consist of a microemulsion, or are saturated through drugs of an informal mixture. Griseofulvin nanosuspensions



are developed by the microemulsion process using H<sub>2</sub>O, taurodeoxycholate sodium salt, butyl lactate, and lecithin.

## 2. Drug Dispersion:

In carriers eutectic Mixtures When two or more compounds are mixed, generally they do not show phase compatibility with each other to generate a new entity, but, at specific fractions, they prevent the crystallization process of one another, which results in a system having a lower melting point than either of the two starting components .Solid Dispersion When using a hydrophilic matrix and a hydrophobic drug, these two different components become molecularly dispersed in amorphous particles (clusters) or crystalline particles . Solid dispersion techniques are discussed in Table 6, along with their BCS class—for example, drug molecules and trade name, type of formulation and their therapeutic uses. A.Solvent evaporation method:

An organic solvent is evaporated after the entire dissolution of both the drug and carrier in solvent evaporation. The dense form is ground, sieved, and dried—e.g., furosemide with eudragits.

## B. Hot-melt extrusion method:

In this method, carriers and active pharmaceutical ingredients are prepared by hot-stage extrusion using a co-rotating twin-screw extruder. The dispersion of drug concentration is 40% (w/w). It is employed for formulating diverse dosage forms—e.g., sustained-release pellets.

## B. Chemical Modifications:

### 1. Ph Adjustment :

This plays a critical role in drug solubility. It can influence the aqueous solubility of drugs. By varying the solution pH, one can alter the charge state of the drug molecules. If the pH of the solution is such that a particular molecule carries no net electric charge, the solute often has minimal solubility and precipitates out of the solution. The pH at which the net charge is neutral is called the isoelectric point (sometimes abbreviated to IEP)

### 2. Hydrotrophy :

This is a solubility sensation using it, the water solubility of the solute can be enhanced by the excess addition of a second solute. The term hydrotrophy was used in earlier reports to describe non-micelle-forming materials, either solids or liquids, organic or inorganic, which are proficient in improving solubility of insoluble substances.

### 3. Salt formation:

Salt Formation Acidic and basic drugs have low solubility in water as compared to their salts. For the development of parenteral administration, the most favored strategy is solubility enhancement by salt formation.

### 4. Co-Crystallization:

Co-crystals are the complexes of non-ionic supramolecular materials. They can be utilized to address issues regarding physical properties, i.e., drug solubility, bioavailability, and stability, without affecting the chemical structure of APIs. Co-crystals are prepared using two or more different molecular units, in which the weak forces are intermolecular interactions such as  $\pi$ - $\pi$  stacking and hydrogen bond interactions. The composition and molecular interaction of pharmaceutical compounds will be changed by co-crystallization, and it is accepted as a good option to optimize the drug characteristics. Co-crystals will offer various routes, where any APIs can be crystallized regardless of belonging to acidic, basic or ionizable groups. This can be helpful for compounds with low pharmaceutical profiles due to their nonionizable functional groups

#### 5.Co-Solvency:

When the structural complexity of newly developed entities rises, the H<sub>2</sub>O solubility of the drug decreases drastically. When the water solubility of a compound is much lower than its therapeutic dose, a blend of solvents is employed to obtain high solubility. Co-solvents are used to enhance the drug's solubility, providing multiple nonpolar groups, thus increasing its aqueous (water) solubility. Co-solvents are necessary for the pharmaceutical formulation, where, sometimes, it may be required to enhance drug solubility.



#### PRE-FORMULATION STUDIES:

Prior to the development of the dosage form, it is essential that certain fundamental physical and chemical properties of the drug molecule and other derived properties of the drug powder are determined. This information dictates many of the subsequent events and approaches in formulation development. This first learning phase is known as Pre-formulation.

#### Organoleptic Properties a) Colour:

A small quantity of powders were taken in butter paper and observed in wellilluminated place.

#### b) Taste and odour:

Very less quantity of powders is tasted and perceived to observe the odor as well. Solubility:

The approximate solubility of substances are indicated by the descriptive terms. Solvents such as Methanol, alcohol and water and isopropyl alcohol are used for the solubility studies.

| <b>Descriptive Term</b>            | <b>Parts of Solvent Required for 1 part of Solute</b> |
|------------------------------------|---|
| Very soluble                       | Less than 1   |
| Freely soluble                     | From 1 to 10  |
| Soluble                            | From 10 to 30   |
| Sparingly soluble                  | From 30 to 100  |
| Slightly soluble                   | From 100 to 1,000                                     |
| Very slightly soluble              | From 1,000 to 10,000                                  |
| Practically insoluble or Insoluble | Greater than or equal to 10,000                       |

**\*Drug excipient compatibility studies:**

Drug Excipients compatibility studies are carried out by mixing the drug with various excipients in different proportions (in 1:1 ratio were prepared to have maximum likelihood interaction between them) was placed in a vial, and rubber stopper was placed on the vial and sealed properly. Studies were carried out in glass vials at Accelerated conditions, 40° C ± 2° C / 75% RH ± 5 % RH for a storage period of 4 weeks. After storage, the sample was compared with control at 2-8° C and observed physically for liquefaction, caking and discoloration.

**Particle size distribution:**

The main aim of sieve analysis is to determine the different size of drug particles present. A series of standard sieves were stacked one above the other so that sieves with larger pore size (less sieve number) occupy top position followed by sieves of decreasing pore size (larger sieve number) towards the bottom.

**Procedure:**

A series of sieves are stacked one over the other arranged in ascending order of increasing mesh number from the top. The stated quantity of powder is placed over the top and are tapped mechanically for 15 to 20 minutes. The powder retained over every mesh and pan is weighed and from this the average mean diameter of the particles in µm is found by using the following formula,

$$\text{Average mean diameter} = \frac{\sum nd}{\sum x}$$

Where n= weight of the powder retained in grams d= arithmetic mean size openings in µm x= percentage weight of the powder retained.

The same procedure is repeated for all the powders.

**Angle of Repose:**

| S.No | Angle of Repose (degrees) | Flow Property              |
|------|---------------------------|----------------------------|
| 1    | 25–30                     | Excellent                  |
| 2    | 31–35                     | Good                       |
| 3    | 36–40                     | Fair—aid not needed        |
| 4    | 41–45                     | Passable—may hang up       |
| 5    | 46–55                     | Poor—must agitate, vibrate |
| 6    | 56–65                     | Very poor                  |
| 7    | >66                       | Very, very poor            |

The angle of repose is the maximum angle that the plane of powder makes with the horizontal surface on rotation. Angle of repose is helpful in assessment of flow properties of particles which could be further related to packing densities and mechanical arrangements of particles.

The angle of repose of granules was determined by the fixed funnel and free standing cone method. The accurately weighed granules were taken in a funnel. The height of the funnel was adjusted in such a manner that the tip of the funnel just touched the apex of the heap of the granules. The granules were allowed to flow through the funnel freely onto the surface. The diameter of the powder cone measured and angle of repose was calculated using the following equation:

$$\tan \theta = h/r$$

Where, h = height of the powder r = radius of the powder heap  $\theta$  = is the angle of repose.

Relation between angle of repose and flow property

\*Determination of Bulk Density and Tapped Density:

An accurately weighed quantity of the granules/ powder (W) was carefully poured into the graduated cylinder and volume (V<sub>0</sub>) was measured. Then the graduated cylinder was closed with lid and set into the tap density tester (USP). The density apparatus was set for 100 taps and after that the volume (V<sub>f</sub>) was measured and continued operation till the two consecutive readings were equal. The bulk density and the tapped density were calculated using the following formulae. Bulk density = W/V<sub>0</sub>

Tapped density = W/V<sub>f</sub> Where,

W = Weight of the powder

V<sub>0</sub> = Initial volume

V<sub>f</sub> = final volume

Carr's Compressibility Index:

An indirect method of measuring powder flow from bulk densities was developed by Carr. The percentage compressibility of a powder was a direct measure of the potential powder arch or bridge strength and stability. Carr's index of each formulation was calculated according to equation given below:

$$\text{Carr's Compressibility Index (\%)} = [(TD-BD) \times 100] / TD$$

Where,

TD = Tapped density

BD = bulk density

Hausner's Ratio :

Hausner's Ratio indicates the flow properties of the powder and is measured by the ratio of tapped

| S.No | Compressibility Index (%) | Flow Character  |
|------|---------------------------|-----------------|
| 1.   | 10                        | Excellent       |
| 2.   | 11–15                     | Good            |
| 3.   | 16–20                     | Fair            |
| 4.   | 21–25                     | Passable        |
| 5.   | 26–31                     | Poor            |
| 6.   | 32–37                     | Very poor       |
| 7.   | >38                       | Very, very poor |

density to bulk density. It is the ratio of tapped density and bulk density. Hausner found that this ratio was related to interparticle friction and, as such, could be used to predict powder flow properties. Generally a value less than 1.25 indicates good flow properties, which is equivalent to 20% of Carr's index.

Hausner's Ratio = Tapped density/Bulk Density Loss on Drying (LOD):

Loss on drying is the loss of weight expressed as percentage w/w resulting from water and volatile matter of any kind that can be driven off under specified conditions. The test is carried out on a well-mixed sample of the substance. If the substance is in the form of large crystals, reduce the size by rapid crushing to a powder.

Procedure:

Loss on drying is performed using the IR moisture analyzer. 1gm of granules was taken and placed in an IR moisture analyzer containing the plate at the centre, spread the granules on to the plate uniformly, and adjust temperature of than analyzer at 105oC. Switch on the analyzer and wait until the alert sound comes from the analyzer, readings was noted down from the digital display

## Methodologies

### 1. Formulation of Antacid bilayer Tablet:

Antacid bilayer tablet that combines the benefits of rabeprazole and domperidone. This comprehensive guide will walk you through each stage of the formulation, from selecting the ingredients to performing quality control measures, ensuring a successful outcome.

### The Need for Antacid Bilayer Tablets:

Explore why antacid bilayer tablets are becoming increasingly popular in the pharmaceutical industry, offering enhanced effectiveness and improved patient compliance.

**Rabeprazole - A Potent Proton Pump Inhibitor** Discover the remarkable properties and mechanism of action of rabeprazole, a powerful proton pump inhibitor that provides long-lasting relief from acid-related disorders.

**Domperidone –**

### An Effective Gastrokinetic Agent

Learn about the unique properties and benefits of domperidone, a gastrokinetic agent that aids in the treatment of digestive disorders by promoting gastric emptying.

### Ingredients of the Antacid Bilayer Tablet:

#### Rabeprazole Layer:

Rabeprazole sodium, microcrystalline cellulose, croscarmellose sodium, magnesium stearate

#### Domperidone Layer:

Domperidone, lactose monohydrate, povidone, croscarmellose sodium, magnesium stearate

#### Common Ingredients:

Hydroxypropyl cellulose, sodium lauryl sulfate, colloidal silicon dioxide, talc .

### Formulation of the First Layer Containing Rabeprazole

#### 1. Blend the Ingredients

Mix rabeprazole sodium, microcrystalline cellulose, and croscarmellose sodium to create a homogeneous blend.

## 2.Add Lubricants

Introduce magnesium stearate into the blend to enhance flowability and prevent tablet sticking.

## 3.Granulation:

Granulate the blend with a suitable liquid binder to form cohesive granules.

## 4.Tableting:

Compression of granules into tablets using a high-speed rotary tablet press.

## Formulation of the Second Layer Containing Domperidone

### Mixing of Ingredients:

Combine domperidone, lactose monohydrate, and povidone to form a uniform mixture.

### Wet Granulation:

Granulate the mixed powders with a suitable binder to obtain granules of desired size and consistency.

### Compression:

Compact the granules into tablets using a suitable compression machine.

### Preparation of the Bilayer :

### Lamination Process:

Learn about the meticulous process of layering the rabeprazole and domperidone tablets together to form a single, cohesive bilayer tablet.

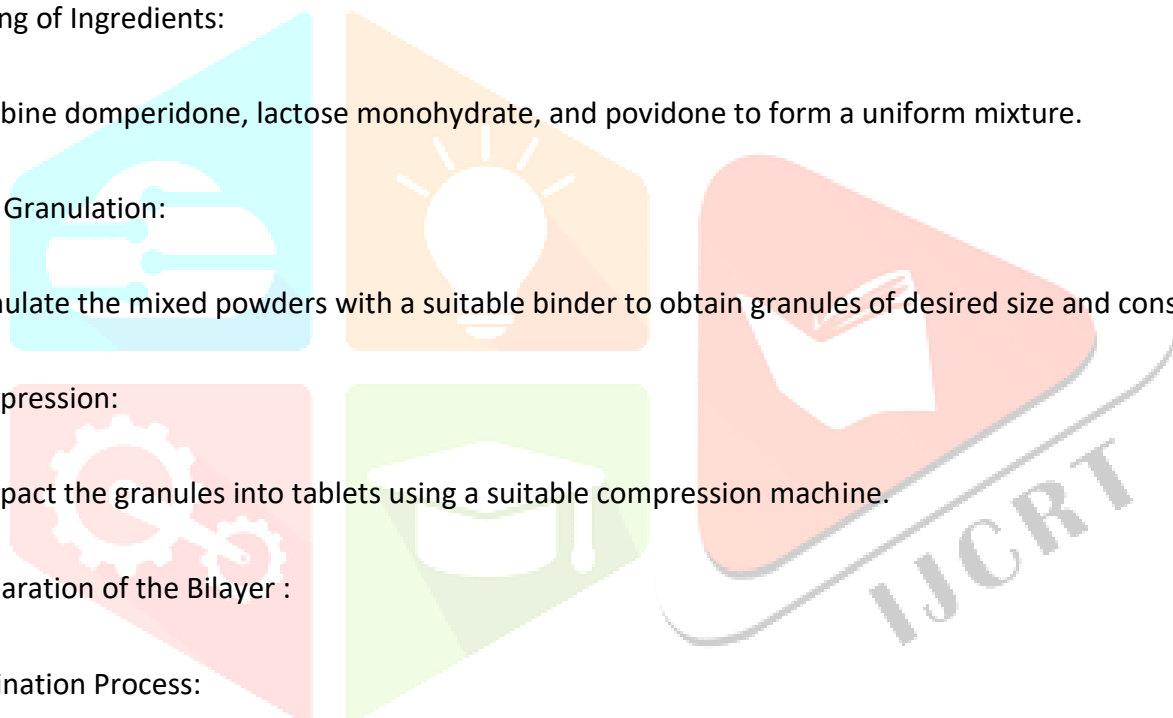

## 1. PREPARATION OF RABEPRAZOLE GRANULES:

### \* Sifting of the granulation Material:

○ The Excipients were sifted by using mechanical sifter by using #40 screens. ○ API should be sifted separately.

### \* Binder preparation:

○ Povidone is dissolved in sufficient quantity of Iso Propyl Alcohol to get a clear solution.

### \* Mixing & granulation(RMG):

○ The excipients Mannitol and Avicel PH102 were loaded into RMG and Mixed for two minutes. ○ After dry mixing add Rabeprazole (API) in to the RMG. Then mix for 15 minutes. ○ Aerosil was added to the dry mixed blend to absorb the moisture in the drug. ○ Then gently add binding agent in to the RMG and mix them thoroughly. By using impellor and chopper blades. ○ After granulation the material is transfer from RMG to the FBD for proper drying.

\*Drying(FBD): ○ The wet mass is dried by using Fluid Bed Dryer.

\* Sifting & milling: ○ The lumps which are formed in the process is separated by sifting. ○ The lumps were milled by using multi mill to reduce the size.

### \*Coating solution preparation:

○ Talc and plastisizer are homogenized in water using homogenizer for 10 min(exceptient suspension)

○ Pour the exceptient suspension slowly into the Enteric coating dispersion while stirring with conventional stirrer.(Spray suspension) ○ Pass the spray suspension through a 0.5mm sieve.

\*Coating of Rabeprazole Granules: ○ The enteric coating of granules was done by using Fluidized Bed Processor (FBP).

○ Before starting the coating process in FBP the spray gun pattern was adjusted in order to get uniform coating.

○ The base plate and mesh was stetted as per the size of the granules. i.e. A plate and 100 # mesh. ○ After proper arrangement the equipment was given for pre warming in order to reach the bed temperature 28-30°C. ○ After attaining the bed temperature the granules were loaded into FBP. ○ Then the subcoating solution was sprayed with the help of peristaltic pump through the spray gun and dried. ○ After subcoating the enteric coating solution was sprayed with the help of peristaltic pump through the spray gun.

○ The coating process was continued until the coating solution gets finished.○ Finally 10- 15 minutes drying has to be given for the coated granules.

○ The granules were collected from the FBP and weighed to check the process efficiency. ○ The main process parameters for the granules are as follows.

### \*Pre lubrication of the granules:

○ The coated granules were loaded in to the octagonal blender.○ Then add previously weighed Avicel PH200 and mixed for 15 min. \*Lubrication: ○ Pre-lubricated granules are lubricated with Magnesium stearate for 2 minutes



## 2. PREPARATION OF DOMPRIDONE GRANULES:

\*Sifting of the granulation Material:

○ Domperidone, HPMCK4, HPMCK15, Avicel PH102 and Lactose talc Magnesium Stearate were sifted by using mechanical sifter by using #40 screens.

\*Dry Mixing: ○ The excipients Lactose and Avicel PH102 and Polymer were loaded into RMG and Mixed for two minutes.

○ After dry mixing add Domperidone (API) in to the RMG. Then mix for 15 minutes.

\*Granulation: ○ Granulation is done by adding sufficient quantity of the water to the dry mixed blend continuously until the granules are formed.

○ After granulation the material is transfer from RMG to the FBD for proper drying.

\*Drying the granules by using : ○ The wet mass is dried by using Fluid Bed Dryer.

\*Sifting & milling: ○ The lumps which are formed in the process are separated by sifting. ○ The lumps were milled by using multi mill to reduce the size \*Lubrication of the granules: ○ The granules were loaded in to the octagonal blender.

○ Then add previously weighed lubricating material Magnesium state and talc.○ Then blend the material for 5 minutes.

## COMPRESSION OF BILAYER TABLETS:

The blends of the two layers obtained are subjected to compression using CADMACH double sided compression machine. Compression involves two steps ○ Compression of the Domperidone layer with the desired parameters. ○ The Domperidone layer compression is followed by the compression of the Rabepazole layer

| S.No | Punch Parameters |                         |
|------|------------------|-------------------------|
| 1.   | Punch dimension  | 10.00 mm.               |
| 2.   | Punch shape      | Circular, Flat punches. |
| 3.   | Upper punch      | Plain.                  |
| 4.   | Lower punch      | Plain.                  |

Formula for immediate release layer:

| Ingredients (Mg)    | G1  | G2  | G3  |
|---------------------|-----|-----|-----|
| Rabeprazole         | 240 | 240 | 240 |
| Cross carmellose Na | 8   | 12  | 15  |
| MCC                 | 52  | 48  | 45  |
| Mg Stearate         | 5   | 5   | 5   |
| Total               | 305 | 305 | 305 |

Formula for sustained release layer:

| Ingredients (mg) | M1   | M2   | M3   | M4   |
|------------------|------|------|------|------|
| Capecitabine     | 500  | 500  | 500  | 500  |
| HPMC K4M         | 110  | -    | 110  | 130  |
| HPMC K15M        | -    | 110  | -    | 110  |
| HPMC K100M       | 130  | 110  | 110  | -    |
| MCC              | 113  | 113  | 113  | 93   |
| Starch<br>20     | 20   | 20   | 20   | 20   |
| Mg Stearate      | 7    | 7    | 7    | 7    |
| Water            | q.s. | q.s. | q.s. | q.s. |
| Total            | 750  | 750  | 750  | 750  |

## Evaluation parameters

### 1. Dissolution Rate:

#### Dissolution Procedure :

The general procedure for a dissolution involves a liquid known as Dissolution Medium which is placed in the vessels of a dissolution unit. The medium can range from degassed or sonicated deionized water to pH adjusted chemically-prepared solutions and mediums that are prepared with surfactants. The dissolution medium should be water or water-based having a pH in the range of 5-7 at 37 °C and medium to be used as per the product which is written in the standard test procedure of the respective product. Degassing the dissolution medium through sonication or other means is important since the presence of dissolved gases may affect results so the drug is placed within the medium in the vessels after it has reached sufficient temperature and then the dissolution apparatus is operated. Sample solutions collected from dissolution testing are commonly analyzed by HPLC and Ultra violet visible spectroscopy. There are criteria known as release specifications that samples tested must meet statistically, both as individual values and as average of the whole and one such criteria is the parameter "Q", which is a percentage value denoting the quantity of dissolved active ingredient within the monograph of a sample solution. If the initial sample analysis, known as S1 or stage 1 testing fails to meet the acceptable value for Q, then additional testing known as stage 2 and 3 testing is required. S3 testing is performed only if S2 testing still fails the Q parameter. If there is a deviation from the acceptable Q values at S3, then an OOS (Out of Specification) investigation is generally initiated.

#### Types of Dissolution Apparatus :

Apparatus 1 – Basket USP Dissolution

Apparatus 2 – Paddle USP Dissolution

Apparatus 3 – Reciprocating Cylinder USP Dissolution

Apparatus 4 – Flow-Through Cell

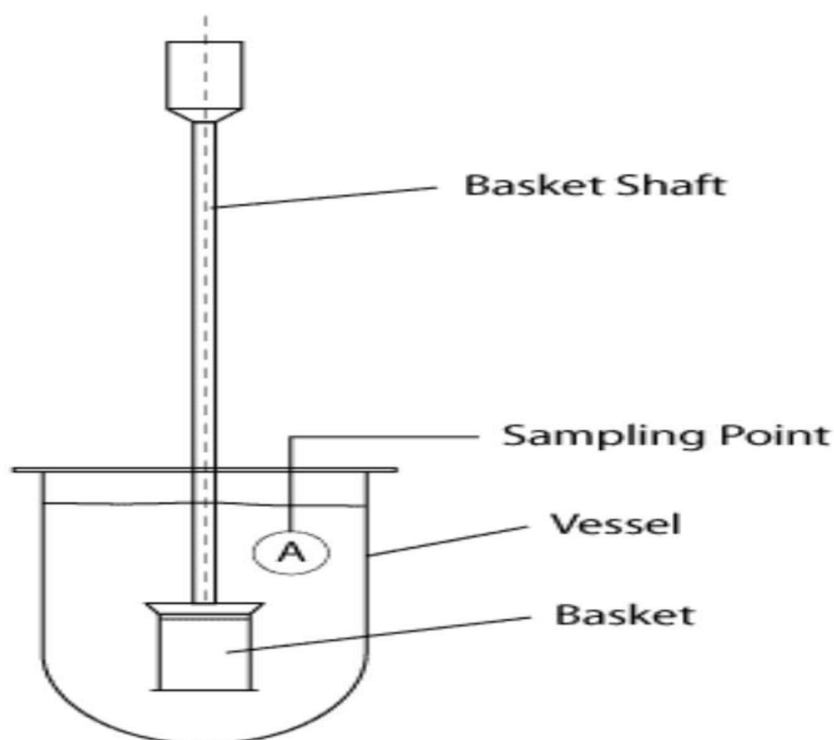

**Apparatus 1 Basket type**

## Disintegration Test:

This test is provided to determine whether tablets or capsules disintegrate within the prescribed time when placed in a liquid medium under the experimental conditions stated below.

### Procedure:

Place one dosage unit in each of the six tubes of the basket and if specified add a disc. Operate the apparatus using water as the immersion fluid unless another liquid is specified and maintain its temperature at 35–39 °C. At the end of the specified time lift the basket from the fluid and observe the dosage units, all of the dosage units have disintegrated completely. If one or two dosage units fail to disintegrate repeat the test on 12 additional dosage units. The requirements of the test are met if not less than 16 of the 18 dosage units tested are disintegrated.

### Types of Disintegration Apparatus:

- 1) Fully Automated Tablet Disintegration Tester Machine. ...
- 2) Semi-automated Tablet Disintegration Testing Machine. ...
- 3) Manual Tablet Disintegration Tester Machines. ...
- 4) Single Disintegration Tester Machines. ...
- 5) 2- Station Semi-automatic Disintegration Tester Machines.

### Content Uniformity:

Content uniformity testing ensures that each tablet unit has similar drug content and is a critical step in developing pharmaceutical products. The principles of content uniformity testing involve sampling units from different parts of the manufacturing process, testing the samples, and analyzing them for the active ingredient. Factors that affect the content uniformity of tablets include process variability, excipients, and formulation.

### Equipment and Materials Required

#### Equipment

1. Samplesplitter
2. Balance
3. UV Spectrophotometer
4. HPLC
5. Data acquisition System Materials

1. Standard solutions of the drug
2. Purified water
3. Acetonitrile
4. Methanol
5. Phosphate buffer solution

### Analytical methods to assess content uniformity:

## 1. HPLC-

The most common method for assessing content uniformity in OSDs is highperformance liquid chromatography (HPLC), observes Andrews. "HPLC has the advantages of flexibility, sensitivity, and ubiquity, and many analytical chemists are trained to use HPLC methods," he says. "The disadvantages, however, are the time and resources needed to prepare samples." "In blending operations, the sample is removed using a sample thief and analyzed by HPLC using a calibration curve for the active ingredient(s)," says Robertson. He explains that the method involves dissolving the tablet in a suitable solvent and analyzing the amount by HPLC against a calibration. Although accurate and repeatable, the disadvantages with HPLC are that measurements are offline, samples have to be removed from the blending process, it is destructive for tablets, and analysis can take several minutes per sample, Robertson highlights



## 2.UV- Spectrophotometry :

Visible

Ultraviolet/visible (UV/Vis) spectrophotometry is another technique that can be used as

an assay for content uniformity measurements. "The absorption at a known, given wavelength for a material will be directly related to the concentration of the material present," Robertson says. "Using this correlation requires the material being analyzed to have a suitable absorption within this spectral range and for the other materials present not to have interfering absorptions, although spectral overlap can generally be accounted for by spectral deconvolution or appropriate curve-fitting quantitative methods." He, however, points out that like HPLC, UV/Vis spectrophotometry is an offline and destructive method.

## 3.IR Spectrophotometry :

Near infraredOver the past decade, there has been an increasing emphasis on quality by design (QbD) and the use of process analytical technology (PAT) to monitor and control pharmaceutical manufacturing processes. "FDA encourages the use of new technologies and PAT techniques, such as NIR spectroscopy, for content uniformity analysis," says Robertson. "NIR spectroscopy can be used throughout the manufacturing process in online, at-line, and offline modes of operation." He explains that one such application involves the online monitoring of the blending process with small NIR instrumentation fitted directly onto the blender, or NIR instrumentation connected to the blender using fiber optics probes. "This setup allows for real-time measurement of the blending process without the requirement to

remove samples for measurement, which is a significant advantage over other techniques, such as HPLC," Robertson says. "Different mathematical approaches can be applied to the spectral analysis to determine when the blend is optimized, without the requirement for quantitative calibrations."

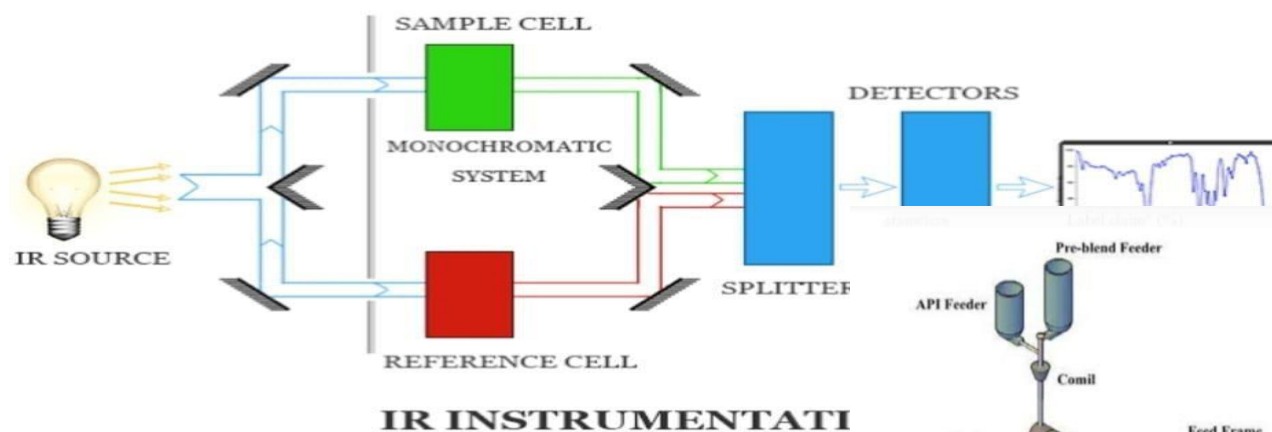

\*Analytical procedure:

The analytical procedure involves extracting the active ingredient from the sample and analyzing it using the UV spectrophotometer or HPLC method. By calculating the ratio of the amount of active ingredient to the weight of each sample, the weight variation statistics can be determined for the batch.

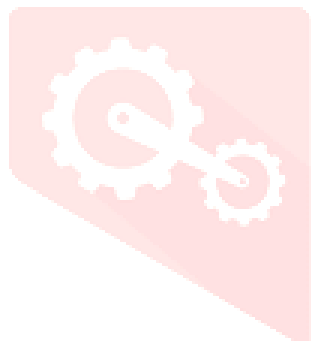
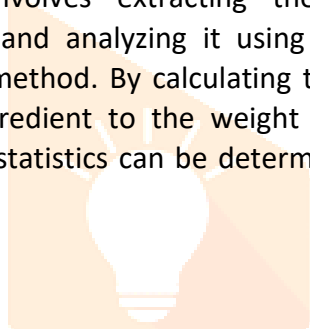
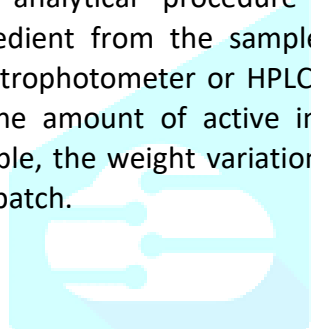
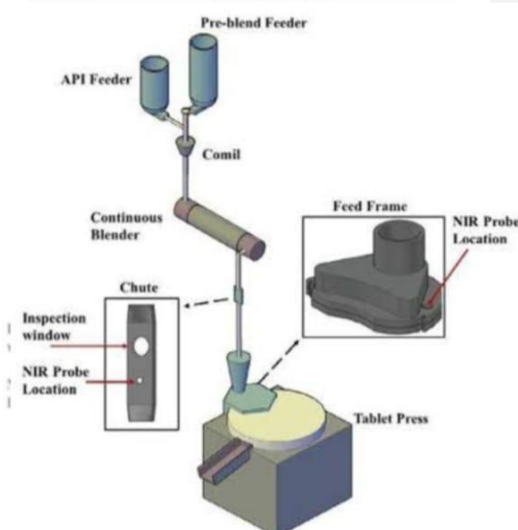

Acceptance Criteria:

Acceptance criteria for content uniformity testing vary by drug category, dosage form, and regulatory standards. Any deviation in the content uniformity test outside the established limits would require an investigation to fix the root cause. Typically, a drug product is deemed pass if the average of individual tablet weights is within the target value of 85–115% of the label claim and if no unit dosage is outside 75–125% of the label claim.

Hardness Test:

The Tablet Hardness test is one of the most important in-process tests for tablets which is performed at the start & in between at specified time intervals during the tablet compression operation.

The tablet hardness test is performed after line clearance during in-process testing and we don't start compression operation until the tablet hardness is not adjusted according to the BMR or batch manufacturing record.

Apparatus Used To Check Tablet Hardness With time, various types of tablet testers were introduced for checking the hardness of tablets and some are given as follows,

1. Monsanto Hardness Tester
2. Strong Cobb Hardness Tester
3. Pfizer Hardness Tester
4. Erweka Hardness Tester
5. Dr Scheluenger Pharmatron Hardness Tester

Monsanto Hardness tester

Friability Test:

Objective of the Test:

The main objective of the friability test is to determine the robustness and resistance of tablets against mechanical stress. This test helps in ensuring that the tablets maintain their physical integrity even under normal conditions of handling and packaging.



Apparatus:

Friability Testing Apparatus  
(Roche Friabilator)  
Standard Sieve (1.70 mm)  
Balance Pan  
Abrasive Charge



Friability test apparatus

Conducting the Test:

1. Verify the calibration of the apparatus and the operational conditions.
2. Weigh approximately 6.5 grams of tablets using a balance.
3. Place the tablets in the drum of the friabilator along with the abrasive charge.
4. Secure the drum and rotate it at a speed of 25 revolutions per minute (RPM) for 4 minutes.
5. After the completion of the test, carefully remove the tablets from the drum and clean them using a clean, dry cloth.





Post compression study:

|                                     | <b>B1</b>   | <b>B2</b>   | <b>B3</b> |
|-------------------------------------|-------------|-------------|-----------|
| <b>Thickness (mm)</b>               | 7.37±0.05   | 7.52±0.11   | 7.63±0.2  |
| <b>Hardness (kg/cm<sup>2</sup>)</b> | 5.84±0.5    | 6.01±0.01   | 6.3±0.1   |
| <b>Weight variation (mg)</b>        | 1054.35±0.5 | 1055.15±0.8 | 1050.8±   |
| <b>Friability (%)</b>               | 0.592       | 0.471       | 0.50      |
| <b>Drug Content (%)</b>             |             |             |           |
| <b>Rabeprazole</b>                  | 97.33±1     | 98.21±0.21  | 96.35±1   |
| <b>Domperidone</b>                  | 96.33±1     | 95.21±1.1   | 96.22±0   |

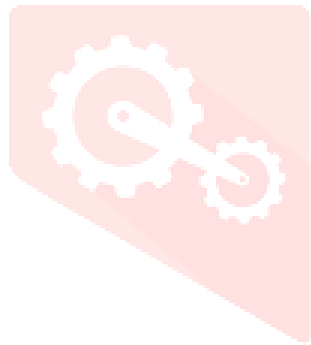

Calibration Curve in Phosphate Buffer:

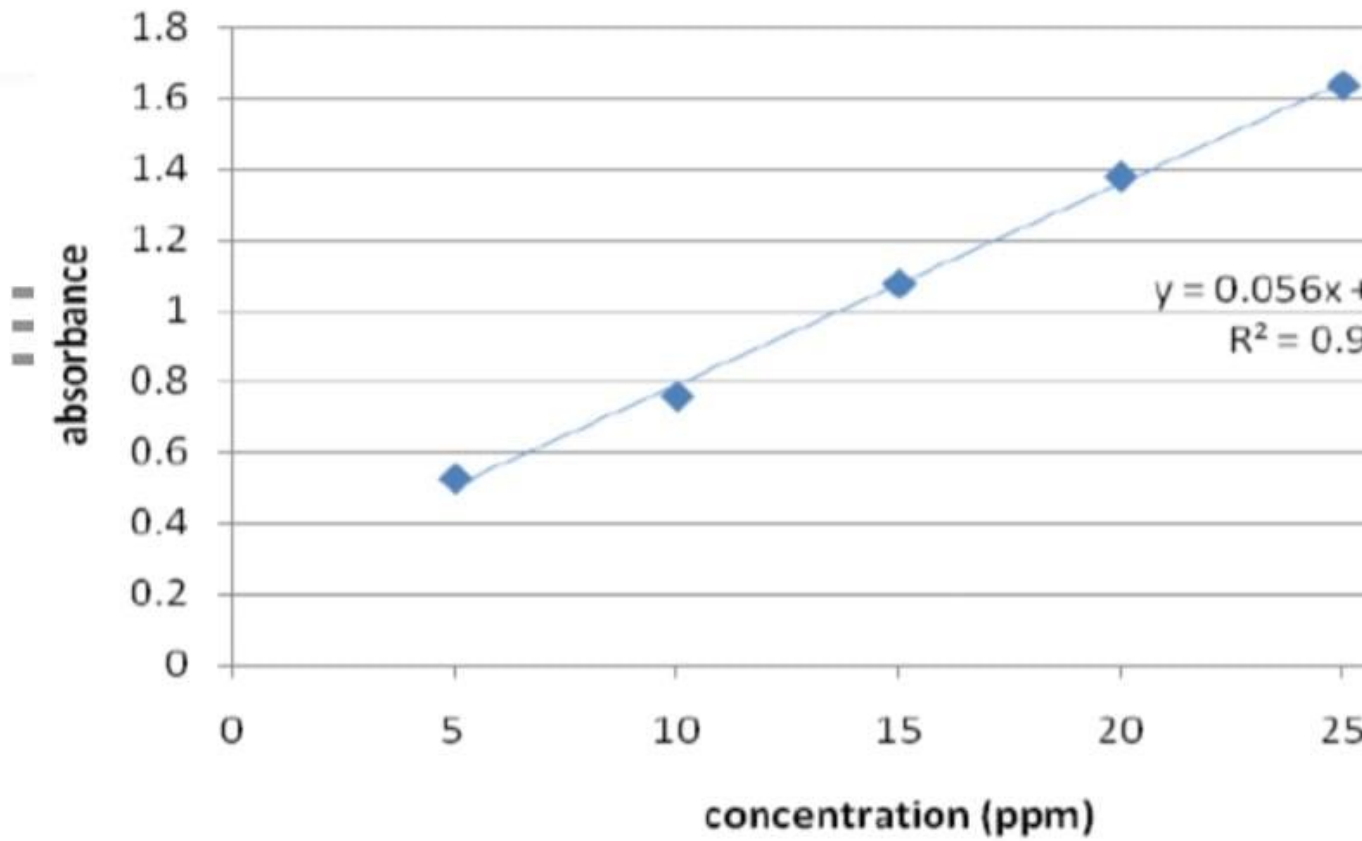

Result and discussion:

1. Compatibility study:

INFRARED SPECTROSCOPY -

| Frequency cm-1 | Groups Assigned |
|----------------|-----------------|
| 3000 – 2800    | C-H             |
| 3100 – 3000    | Ar-H            |
| 1750-1650      | C=O             |
| 1350-1250      | C-N             |
| 1050-1000      | S=O             |

By using FTIR technique, Rabeprazole and Domperidone drug was identified in pure form and in combination of excipients used in formulation of bilayer Tablet.

IDENTIFICATION OF DRUG –

IR SPECTRA DATA

FOR PURE RABEPRAZOLE:

|  |  |
|--|--|
|  |  |
|--|--|

FOR PURE DOMPERIDONE:

| Frequency cm <sup>-1</sup>    | Group Assigned |
|-------------------------------|----------------|
| 1. 2850-2960 cm <sup>-1</sup> | C-H            |
| 2. 1700 cm <sup>-1</sup>      | C=O            |
| 3. 3300-3500 cm <sup>-1</sup> | N-H            |

2) Preparation of standard curve of Rabeprazole and Domperidone:

A. Rabeprazole:

Determination of  $\lambda_{max}$  in pH 6.8 solution

The solution of Rabeprazole in above medium was scanned in order to determine the  $\lambda_{max}$  for its estimation in the respective media.

Fig - Spectrum of Rabeprazole in 6.8 pH

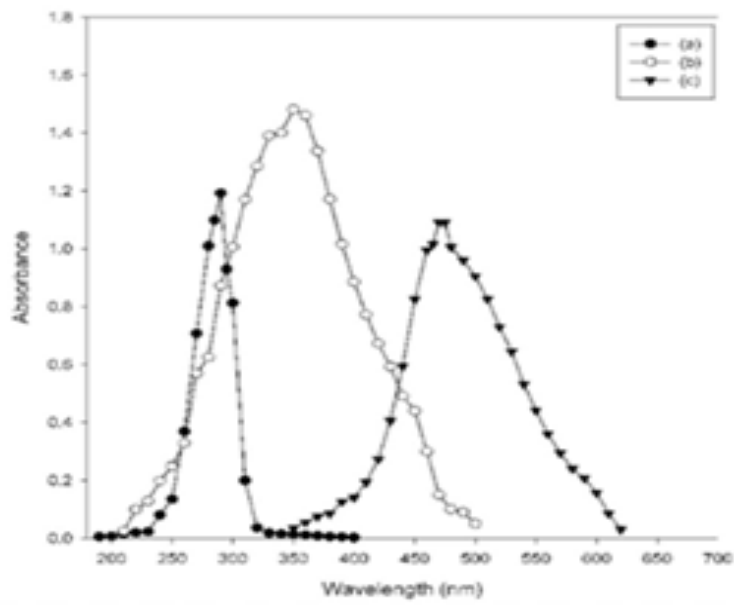

solution.

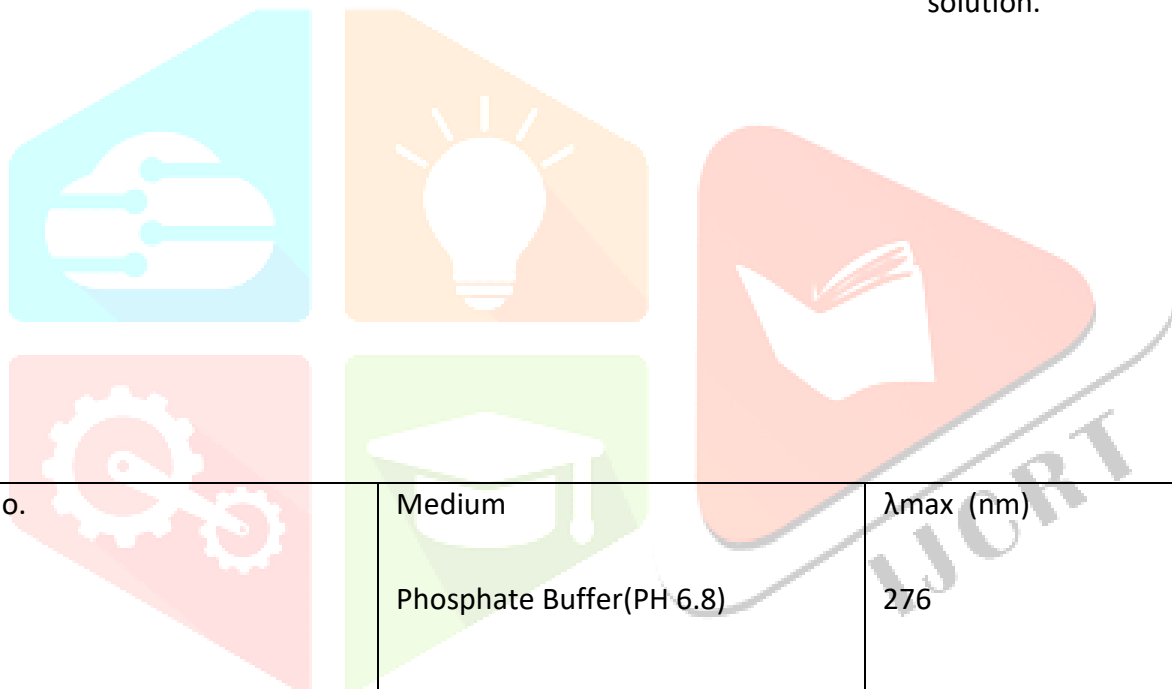

| Sr. No. | Medium                   | $\lambda_{max}$ (nm) |
|---------|--------------------------|----------------------|
| 1.      | Phosphate Buffer(PH 6.8) | 276                  |

Absorbance of Rabeprazole different concentration at  $\lambda_{max}$  276 nm:

| Sr No. | Concentration. | Absorbance |
|--------|----------------|------------|
| 1.     | 2              | 0.07       |
| 2.     | 4              | 0.121      |
| 3.     | 6              | 0.181      |
| 4.     | 8              | 0.245      |
| 5.     | 10             | 0.297      |
| 6.     | 12             | 0.37       |
| 7.     | 14             | 0.421      |
| 8.     | 16             | 0.483      |
| 9.     | 18             | 0.544      |
| 10.    | 20             | 0.61       |
| 11.    | 22             | 0.56       |
| 12.    | 24             | 0.722      |
| 13.    | 26             | 0.789      |
| 14.    | 28             | 0.838      |
| 15.    | 30             | 0.645      |

Callibration curve of rabeprazole in PH 6.8

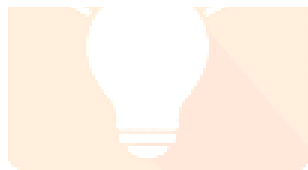
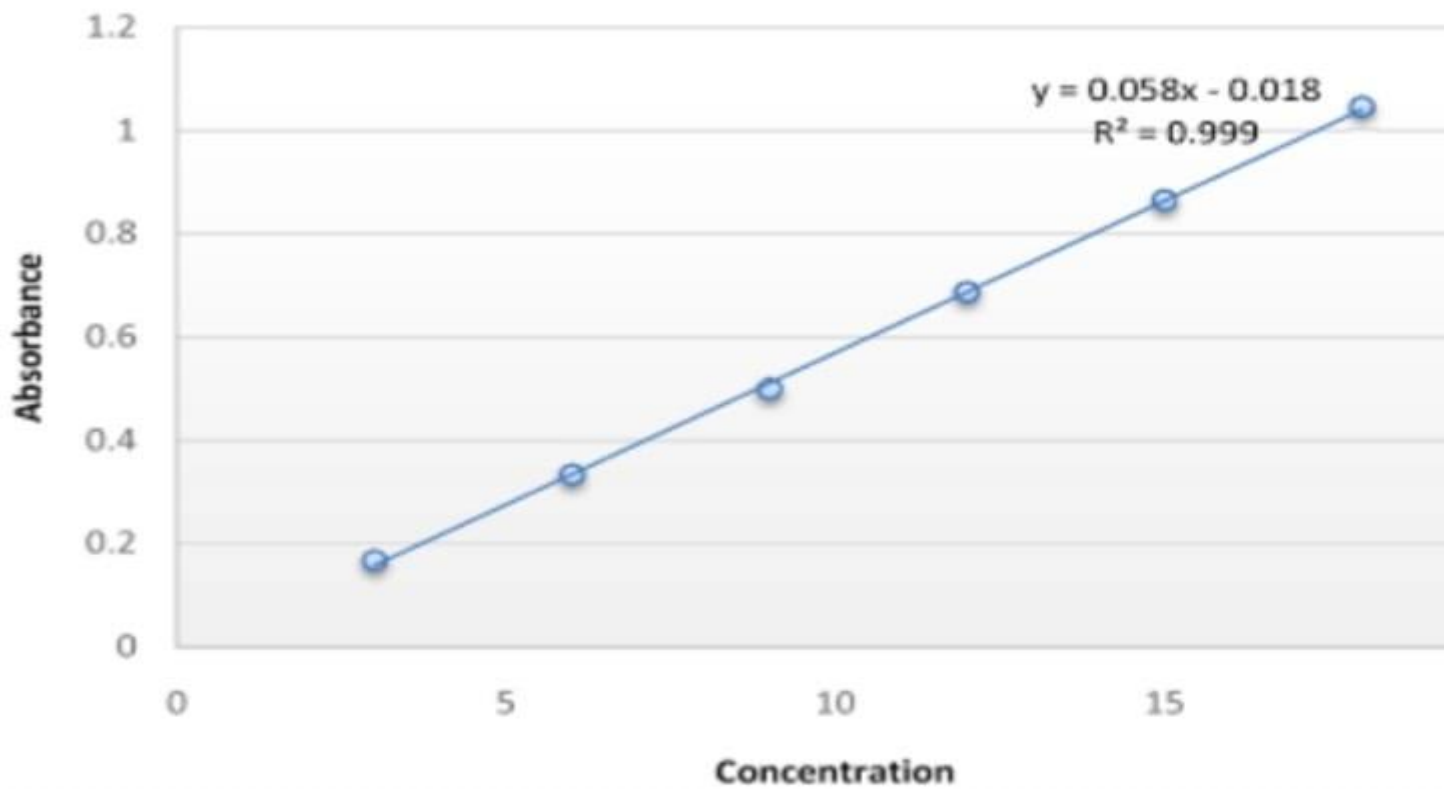

#### B. DOMPERIDONE:

Determination of  $\lambda_{max}$  in pH 6.8 solution.

The solution Of Domperidone in above medium was scanned in order to determine the  $\lambda_{max}$  for its estimation in the respective media.

Fig Spectrum of Domperidone in 6.8 pH solution.

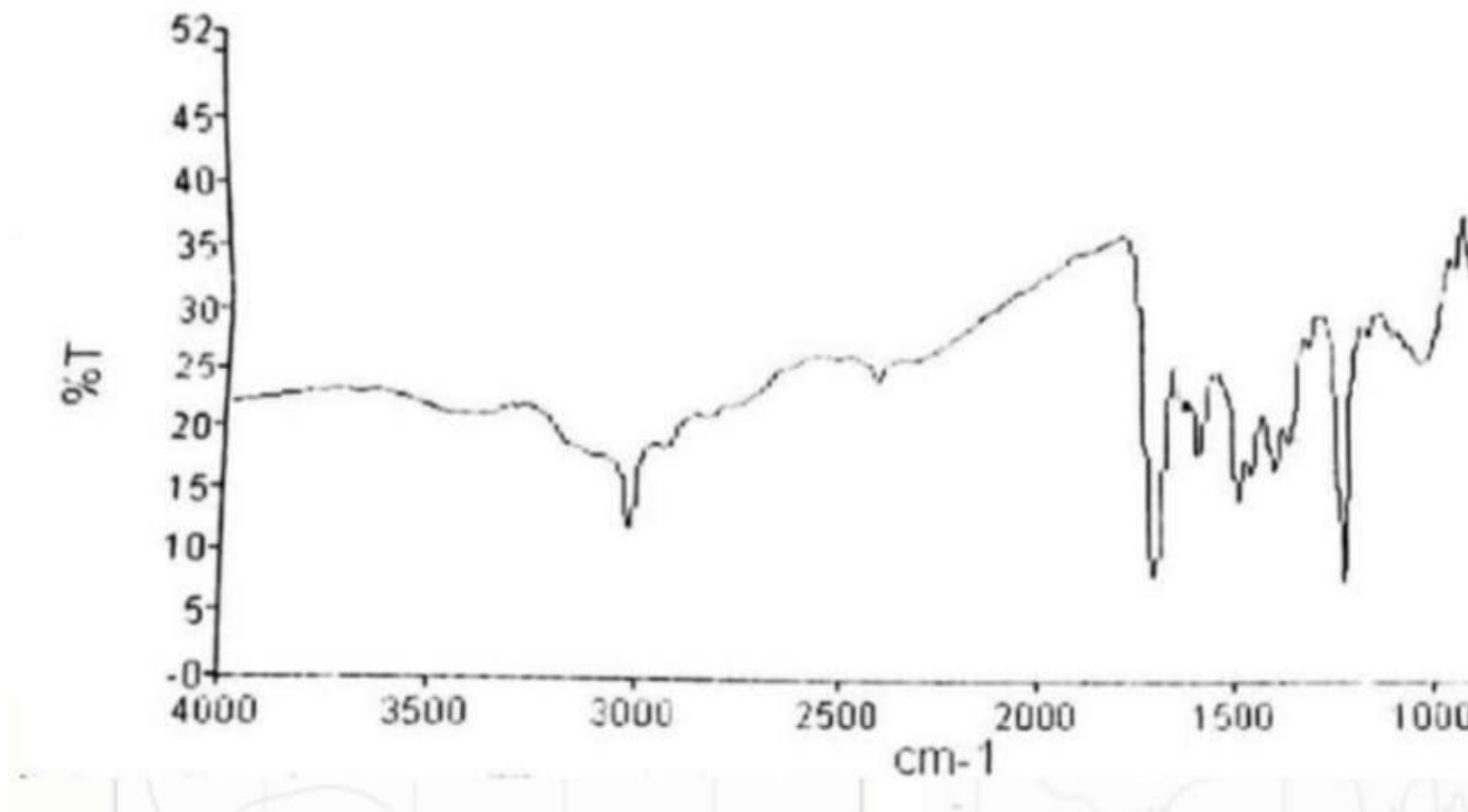



$\lambda_{\text{max}}$  of Domperidone in pH 6.8

| Sr. No . | Medium                    | $\lambda_{\text{max}}$ (nm) |
|----------|---------------------------|-----------------------------|
| 1.       | Phosphate buffer (pH 6.8) | 284                         |

Absorbance of Domperidone in different concentration at  $\lambda_{\text{max}}$  284 nm

| Sr. No. | Concentration | Absorbance |
|---------|---------------|------------|
| 1.      | 2             |            |
| 2.      | 4             | 0.123      |
| 3.      | 6             | 0.182      |
| 4.      | 8             | 0.225      |
| 5.      | 10            | 0.296      |
| 6.      | 12            | 0.38       |
| 7.      | 14            | 0.41       |
| 8.      | 16            | 0.42       |
| 9.      | 18            | 0.541      |
| 10.     | 20            | 0.62       |
| 11.     | 22            | 0.54       |
| 12.     | 24            | 0.724      |
| 13.     | 26            | 0.784      |
| 14.     | 28            | 0.831      |

|     |    |       |
|-----|----|-------|
| 15. | 30 | 0.642 |
|-----|----|-------|

Calibration curve of Domperidone in pH 6.8 at 284 nm

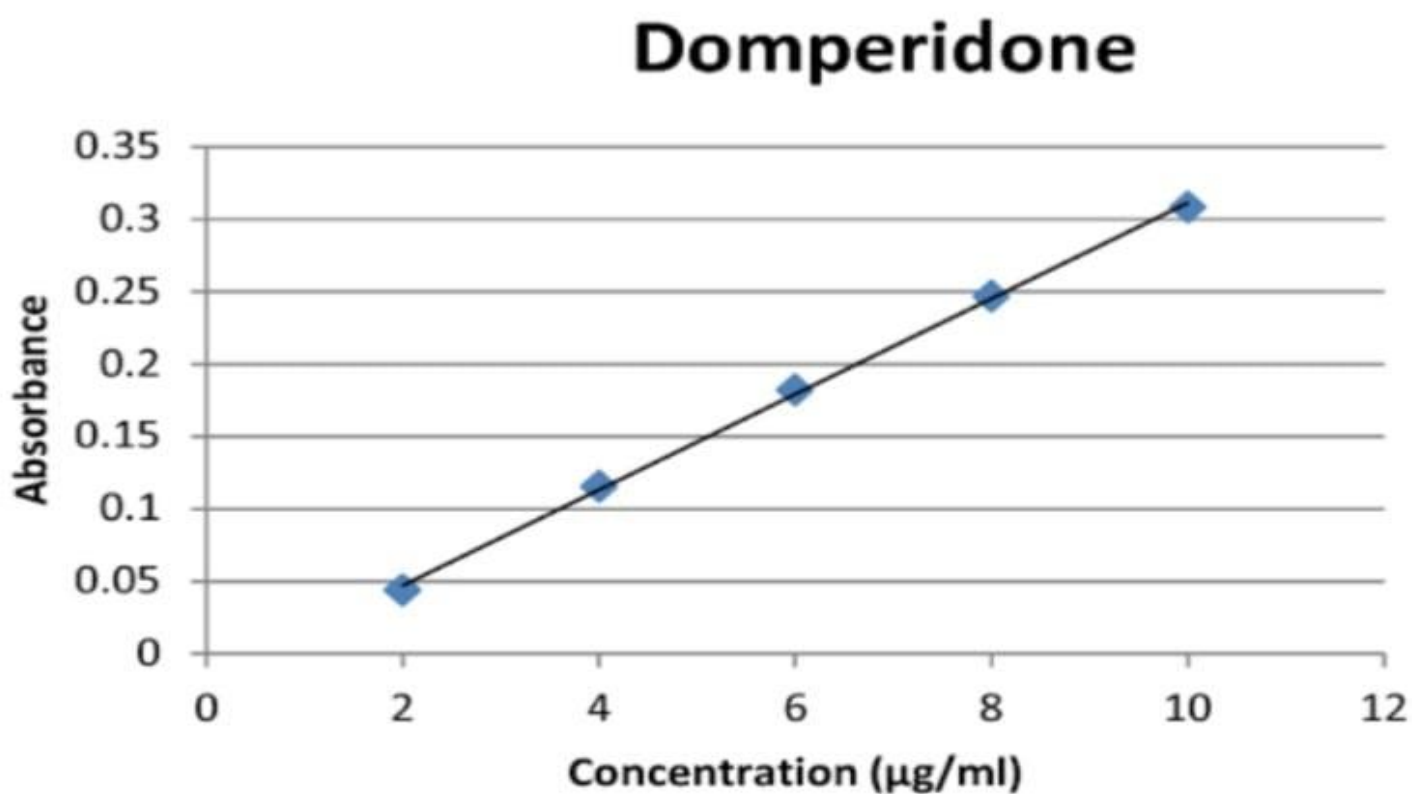

### 3.PREFORMULATION STUDY:

Identification of pure drug

The IR spectrum of pure drug was found to be similar to the reference standard IR spectrum of Rabepazole and Domperidone.

b. Organoleptic properties

## 1. Rabeprazole:

| Sr.no. | Description | Result               |
|--------|-------------|----------------------|
| 1.     | Appearance  | White powder         |
| 2.     | Odour       | Characteristic odour |
| 3.     | Solubility  | Soluble in water     |

## 2.Domperidone

| Sr.no. | Description | Result                      |
|--------|-------------|-----------------------------|
| 1.     | Appearance  | White to pale yellow powder |
| 2.     | Odour       | Characteristic odour        |
| 3.     | Solubility  | Soluble in water            |

## C.Melting point determination:

The melting point Rabeprazole and Domperidone was found to be in the range of 110-121 °C and 223-228 °C respectively.

## D.Density study on pure form of Rabeprazole :

| <b>Bulk Density<br/>±SD<br/>(n= 3 )<br/>gm/ml</b> | <b>Tapped<br/>Density<br/>±SD<br/>(n= 3 )<br/>gm/ml</b> | <b>Angle of<br/>Repose<br/>±SD<br/>(n= 3 )</b> | <b>Compressibility<br/>Index<br/>±SD<br/>(n= 3 )</b> | <b>Hausner<br/>Ratio<br/>±SD<br/>(n= 3 )</b> |
|---|---|--|--|--|
| 0.65±0.01893                                      | 0.714 ±<br>0.03   | 22.16° ±<br>1.54                               | 13.86 ± 2.97   | 0.064  |

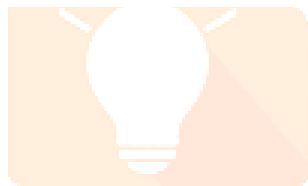

Precompression Study:



| <b>Bulk Density</b><br><b>±SD</b><br><b>(n= 3 )</b><br><b>gm/ml</b> | <b>Tapped</b><br><b>Density</b><br><b>gm/ml</b><br><b>±SD</b><br><b>(n= 3 )</b> | <b>Angle of</b><br><b>Repose</b><br><b>±SD</b><br><b>(n= 3 )</b> | <b>Compressibility</b><br><b>Index</b><br><b>%</b><br><b>±SD</b><br><b>(n= 3 )</b> | <b>Haus</b><br><b>±SD</b><br><b>(n= 3 )</b> |
|---|---|--|--|---|
| 0.851 ±<br>0.03   | 0.914 ±<br>0.05   | 25.74 <sup>0</sup> ±<br>1.50                                     | 6.8 ±<br>1.05  | 1.07 ±<br>0.46                              |



## CONCLUSION

In this present study formulations of coated rabeprazole granules and Domperidone are formulated into a bilayer tablet.

The rabeprazole compressible enteric coated granules were prepared by using different enteric coated polymers such as HPMC Phthalate, Eutragit NE30D and Kollicoat MAE30DP with different ratios and plasticized with PEG. The Omeprazole

granules which are coated with 8% Eutragit and plasticized with 2%PEG meet the USP criteria in drug release. From the above data it is evident that the formulation F7 shows satisfactory drug release both on acid phase and buffer phase and complies with all the pharmacopoeial limits before and after the stability studies and is the most suitable composition for the delayed release of rabeprazole.

Two different grades of HPMC polymer are used to study the release retarding activity. Different concentrations of polymer are used in the sustained release layer

and their effect on the release of Domperidone is explored. The formulation is

found to be the best formulation since it meets the USP criteria in the drug release.

HPMC of grade K4M and K15M at a concentration of 20% and 10% releases the drug as per the USP specifications. The cumulative drug release at the end of twelfth hour

is 100%.From the above data it is evident that the formulation F7 shows satisfactory

sustained release and complies with all the pharmacopoeial limits before and after the

stability studies and is the most suitable composition for the sustained release of

Domperidone.

Finally I conclude that formulation shows the best release in both the layers

(rabeprazole and Domperidone) and that may fulfils the objective of the study.

The stability studies were performed according to in-house specifications for

the optimized formulation. The tablets were kept at accelerated condition ( $40\pm 2^{\circ}\text{C}/$

$75\pm 5\%$  RH) for a period of three months. The obtained results were within the

specifications.

#### REFERENCES:

1. Ding X, Alani AWG, Robinson JR. Extended release and targeted drug delivery systems. In : The Science and Practice of Pharmacy. 2005; (Remington, Ed.), Twenty first edition, volume 1, pp. 939-964 ; Lippincott Williams and Wilkins.
2. Karande A.D., Dhoke S.V., Yeole P.G. Formulation and evaluation of bilayer tablets with antihypertensive drugs having different release patterns. Indian Drugs, 2006; 43(1): 44-50.
3. R.Nagaraju and Rajesh Kaza. Formulation and evaluation of bilayer sustained release tablets of Salbutamol and Theophylline. International Journal of Pharmaceutical Sciences and Nanotechnology, 2009; 2(3): 638-646.
4. Shailesh kumar, Venkata Bala Krishna Rao, N.Kannapan, Amitsankar Dutta. Formulation and evaluation of Atorvastatin calcium and Nicotinic acid in a bilayer tablets. Journal of Pharmacy Research, 2009; 2(7): 1256-1258.
5. Pharmaceutics, The science of dosage form design, Aulton M.E, 2nd edition, 1998, 1,

289-306, 412.

6. Modern Pharmaceutics, Gilbert S. Banker Christopher T. Rhodes, 4th edition, 2006,

121, 501-514.

7. The Theory and practice of Industrial Pharmacy, Leon Lachmann., Herbert

A. Liebermann., Joseph L. Kanig, 2nd edition, 2003, 1, 330-331.

8. Martino Fusca, Dagmer Farber, Heppenheim, Patented on Multilayer tablets, 2001

Patent No. US 6,254,886 B1

9. Sachin S. Kale, Viraj S. Saste, Prajka L. Ughade, Dheeraj T. Baviskar. Review article

on Bilayer Tablets. International Journal of Pharmaceutical Sciences Review and

Research. 2011, Volume 9, Issue 1: 25-30

10. Jitendra R. Amrutkar, Mohan G. Kalaskar, Varsha G. Shrivastav, P.G. Yeole. Bilayer

tablets of Metformin hydrochloride and Glilclazide. A Novel approach in treatment of diabetes, international Jour of Pharm Research and Development, 2009; 1(2).

11. Wen H, Park K. Fluid bed coating and granulation for CR delivery In : Oral

controlled release formulation design and drug delivery: theory to practice. 2010:.

115-121 ; John Wiley and Son

12. Brahmkar DM, Jaiswal BS. Controlled release medication. In: Biopharmaceutics

and Pharmacokinetics a treatise. 1995: pp. 335-371, Vallabh Prakashan

13. Sansom LN. Oral extended release products. Aust Prescr. 1999 ; 22: 88-90.

14. Richards JH. Role of polymer permeability in the control of drug release. In: Polymer

permeability. 1985; ( Comyn J, Ed.), pp : 220-256; Springer

15. Chinam Niranjana Patra, Arethi Bharani Kumar, Hemat Kumar Pandit, Satya Prakash



singh, Meduri vimala devi. Design and evaluation of Sustained Release Bilayer

tablets of propranolol hydrochloride. Acta Pharm; 2007; 57: 479-489.

16. Physical Pharmacy, Martin's, P.S Patrick J. 5th edition, 2006, 1, 337-354, 553-558.

17. Ding X, Alani AWG, Robinson JR. Extended release and targeted drug delivery systems. In : The Science and Practice of Pharmacy. 2005; (Remington, Ed.), Twenty first edition, volume 1, pp. 939-964 ; Lippincott Williams and Wilkins.

18. Rane M, Parmar J, Rajabi-Siahboomi. Hydrophilic matrices for oral extended release:

influence of fillers on drug release from HPMC matrices. Pharma Times. 2010 ; 42:

41-45.

19. Brahmkar DM, Jaiswal BS. Controlled release medication. In: Biopharmaceutics and Pharmacokinetics a treatise. 1995: pp. 335-371, Vallabh Prakashan.

20. Qiu Y. Rational design of Oral modified release drug delivery systems. In:

Developing solid oral dosage forms Pharmaceutical theory and practice. 2009; (Qiu,

Y , Chen, Y,and Zhang, GZ,Eds.), pp. 469-499, Elsevier.

21. Sanjahan Abdul, Anil V. Chandewar, Sunil B. Jaiswal, A flexible technology for

Modified-Release drugs, J. Of Controlled release, 147 (2010) 2-16.

22. V.S.N. Murthy, and J.Vijaya Ratna, Key formulation variables in Tableting of

Coated Pellets, Indian J.of Pharmaceutical Sciences, 2008, pp.555-564

23. Ann Debunne, Chris Vervaet, Debby Mangelings, Jean-Paul Remon, Compaction of

enteric-coated pellets: influence of of formulation and process parameters on tablet

properties and invivo evaluation, European J. Of Pharmaceutical sciences, 22(2004):

305-314.

24. A.Dashevsky, K.Kolter, R.Bodmeier, Compression of pellets coated with various aqueous polymer dispersions, International J.of Pharmaceutics 279(2004): 19-26.

