



Design And Development Of An SPM For Bearing Cage Assembly

1MOHASIN A. AJREKAR, 2A.B.PATIL

1Masters Student, 2Assistant Professor, DIEMS

1Dr. Babasaheb Ambedkar Technological university,

2Dr. Babasaheb Ambedkar Technological university

Abstract

Bearing is one of the most critical machine element in every rotating equipment. Its performance is crucial for proper functioning of the equipment. The performance of the bearing is dependent on its components, its manufacturing precision and the proper assembly of the bearing components. In bearing assembly process the assembly of the retainer/cage and the rolling elements plays a vital role with regards to the functioning of the rolling elements to carry the load evenly. This work is focused on the assembly of brass cage of Cylindrical roller bearing. The proper locking or riveting of the cage of a Cylindrical Roller Bearing is important otherwise it will lead to bearing failure. In this work a special purpose machine is design and developed to ensure correct locking/ riveting of the brass cage. The concept orbital riveting is used in the machine which ensures sufficient flaring of the material of the brass cage resulting in strong locking of the bearing cage. The machine developed are giving positive results in terms of the productivity and the quality of the cage locking process.

Keywords: Orbital Riveting, Design, Development, Cost TRIZ, SPM, Productivity

1. Introduction

1.1 Cylindrical Roller Bearings

Cylindrical roller bearings (CRBs) have a simple structure with their cylindrical rollers in linear contact with the raceways. They offer high load capacity under primarily radial loads. Low friction between the rollers and ring ribs makes these bearings suited for high-speed rotation.

Cylindrical roller bearings are available in a wide range of designs, series, variants and sizes. The main design

differences are the number of roller rows and the inner/outer ring flanges as well as cage designs and materials.

The bearings can meet the challenges of applications faced with heavy radial loads and high speeds. Accommodating axial displacement (except for bearings with flanges on both the inner and outer rings), they offer high stiffness, low friction and long service life.

Cylindrical roller bearings are also available in sealed or split designs. In sealed bearings, the rollers are protected from contaminants, water and dust, while providing lubricant retention and contaminant exclusion. This provides lower friction and longer service life. Split bearings are intended primarily for bearing arrangements which are difficult to access, such as crank shafts, where they simplify maintenance and replacements



Figure 1: Cylindrical Roller Bearing

1.2 Cylindrical Roller Bearing Types

- NU, N, NNU, NN: Suitable as free-end bearings.
- NJ, NF: Can sustain limited axial loads in one direction.
- NH, NUP: Suitable as fixed-end bearings. NH types are comprised of a NJ-type CRB with a HJ-type L-shaped thrust collar.

Single-row bearings are designated as NU, NJ, NUP, N, or NF, while double-row bearings are designated as NNU or NN, depending on if side ribs are used. All types allow the inner and outer rings to be separated. Some CRBs used as free-end bearings have no ribs so that the rings can move axially relative to each other. When the inner or outer ring has ribs on both sides and the other ring has a rib on one side, these bearings can take some axial load in one direction.

Double-row cylindrical roller bearings have high radial rigidity and are used primarily for the main shafts of precision machine tools. Cages are typically made of pressed steel or machined brass, but molded polyamide resin cages are used for some models. The main difference between cylindrical roller bearings and other bearing styles is in the name – they use cylinders as the rolling elements as opposed to the balls, you'd find in ball bearings. The cylinders are slightly greater in length than diameter. Compared to ball bearings, cylindrical rollers have a greater radial load capacity. The cylindrical roller design also allows these parts to accept

relatively faster speeds than other styles of roller bearings.

There are multiple types of cylindrical roller bearings. Single row cylindrical rollers are the most popular and are separable, which makes for easier mounting and dismounting. However, these may not be able to support the radial load of certain applications. Double row and multi-row cylindrical roller bearings offer greater radial load capacity and can also transmit axial loads in one direction.

Like other styles, cylindrical roller bearings have various clearance and lubrication options available depending on the manufacturer and supplier. Cylindrical roller bearings can be made with a cage or as a full complement part.

A wide variety of CRBs to suit industry needs:

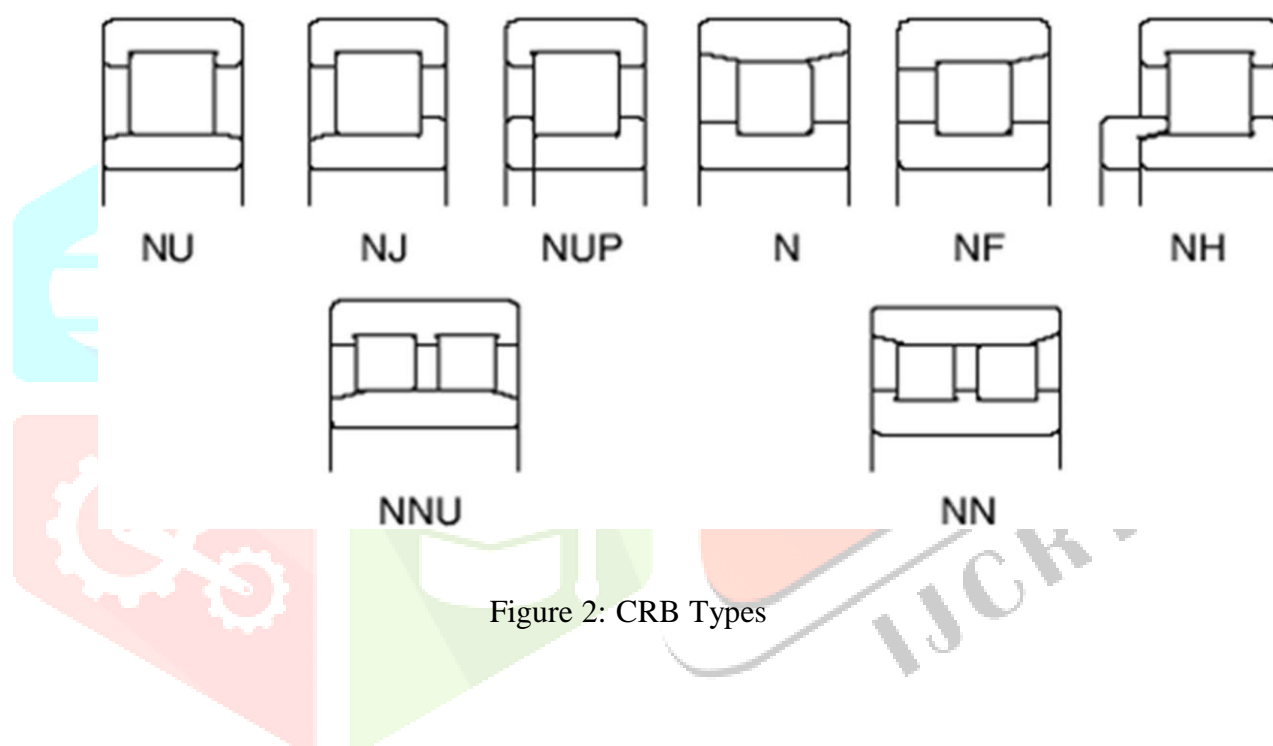

Figure 2: CRB Types

1.3 Materials

Following raw materials are being used for cylindrical roller bearings manufacturing to achieve design life of bearing.

1.3.1 Materials for Inner/Outer races and Roller's

Bearing rings and rolling elements can be made of a number of different materials, but the most common is "chrome steel", (high carbon chromium) a material with approximately 1.5% chrome content. Such "chrome steel" has been standardized by a number of authorities, and there are therefore a number of similar materials, such as: AISI 52100 (USA), 100CR6 (Germany), SUJ2 (Japan) and GCR15 (China).

1.3.2 Materials for bearing cages

- Sheet steel (stamped or laser-cut)
- Polyamide (injection molded)
- Brass (stamped or machined)
- Steel (machined)

The choice of material is mainly done by the manufacturing volume and method. For large- volume bearings, cages are often of stamped sheet-metal or injection molded polyamide, whereas low volume manufacturers or low volume series often have cages of machined brass or machined steel. For some specific applications, special material for coating (e.g., PTFE coated cylindrical bore for vibratory applications) is adopted.

1.4 Types of Cages

Steel Cages Stamped-steel cages for cylindrical roller bearings consist of low-carbon steel and are manufactured using a series of cutting, forming, and punching operations. These cages are made in a variety of different designs and are suitable for most general-purpose cylindrical roller bearing applications. One specific type is the S-type design for the 5200 series cylindrical roller bearing, which is a land-riding cage piloted on the outer ring ribs. This design has depressed cage bridges which evenly space the rolling elements and retain them on the outer ring. Stamped steel cages are easily mass produced and can be used in high temperature and harsh-lubricant environments

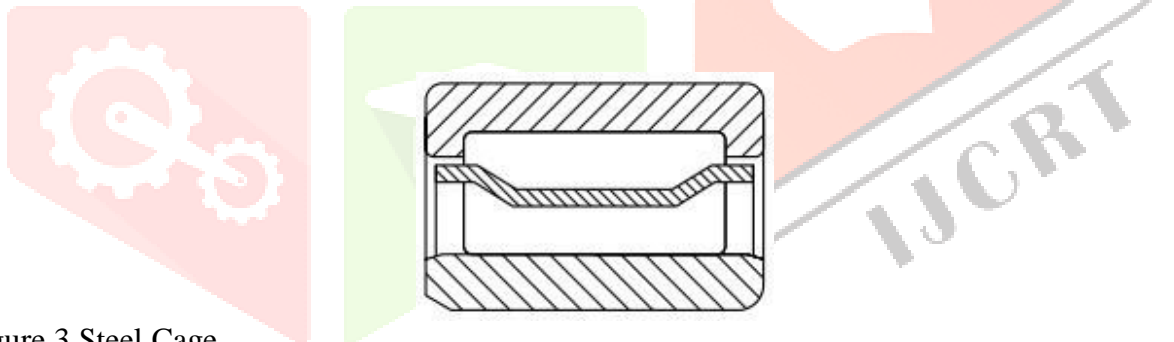

Figure 3 Steel Cage

Pin Type Cage Pin-type cages for cylindrical roller bearings consist of two rings and a series of pins running through the center of the rolling elements. These cages are used for large diameter cylindrical roller bearings where machined brass cages are not available. With this design, additional rollers can typically be added, resulting in increased load capacity.

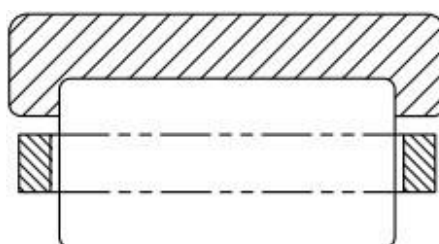

Figure 4: Pin type Cage

Machined cages are an option for smaller cylindrical bearing sizes, and are typically made from brass. Machined cage designs for cylindrical roller bearings offer increased strength for more demanding applications. Designs can be one-piece or two-piece cages. One-piece designs can be either a finger-type as shown in fig. 4 or a standard cage configuration having fully milled pockets. The one-piece finger type and the two-piece design with cage ring (fig.5) are more common in standard cylindrical roller bearings. They also are roller-guided designs. The one-piece version with fully milled roller pockets (fig. 6) is our premium cage. This cage is used with our EMA series bearings. Unlike traditional roller-riding cages, it is a land-riding cage which minimizes drag on the roller elements. This reduces heat generation, resulting in improved bearing life. Compared to a two-piece design, this one-piece cage also reduces heat and wear by enhancing lubrication flow.



Figure 5: Machined Cages

Bearing companies often recommend bearings with brass cages as they are a prerequisite for very demanding applications. It is also a fact that steel is stronger than brass. The simple reason why brass cages are so big (voluminous) is that they must have such dimensions to stand the dynamic forces. They are problem solvers in applications subjected to very heavy impact loads the reason for this favorable feature is that brass is softer (lower young's modulus value)

1.5 Bearing characteristics

The rollers and the raceways are in contact with the wire or repaired, and have a high radial load capacity, making them suitable for bearing heavy and impact loads.

The friction coefficient is small, making them suitable for high speeds, with a limit speed close to that of a deep groove ball bearing.

N-type and NU-type bearings can move axially, which allows them to adapt to changes in the relative position of the shaft and the housing caused by thermal expansion or installation error, and can be used as free-end support.

The shaft or seat hole's machining requirements are high. After installation, the relative deflection of the outer ring axis should be strictly controlled to avoid contact stress concentration.

The inner or outer ring can be separated for easy installation and removal.

1.6 Bearing Application

With their combination of greater radial load capacity, ability to accommodate faster speeds, and other benefits, cylindrical roller bearings are ideal for use in a variety of industries.

Typical markets that can utilize these parts include:

- Large and medium motor
- Locomotive vehicle
- Machine tool spindle
- Internal combustion engine
- Generator
- Gas turbine
- Gearbox
- Rolling mill
- Vibrating screen
- Lifting and transport machinery

1.7 Various Causes of Cylindrical Roller Bearings Failures

Like all other types of bearings, cylindrical rollers require care and maintenance. Flaking or pitting, cracking and chipping, scratches, and rust are among the most common causes of cylindrical roller bearing failure.

Fortunately, you can limit the risk of bearing failure. There are preventative measures you can take to reduce the risk of bearing damage. Check out our posts on what you can do to help prevent or detect the following potential problems:

- Contamination, improper mounting, and misalignment
- Corrosion, lubrication, fluting, and fatigue
- Overheating, excessive loads, improper storage or handling, and improper fit

1.8 Bearing Assembly Process

Bearings are generally manufactured according to their tolerance class as per IS standard, to meet the desired tolerance class. Inner ring, Outer ring, and rollers are sized. After segregation of Inner, Outer races as per their groupings, rollers are separated with the help of roller separator tool. Then rollers are filled in the required cages and pressed their cover in it. Below figure shows the various stages of bearing assembly and its component.

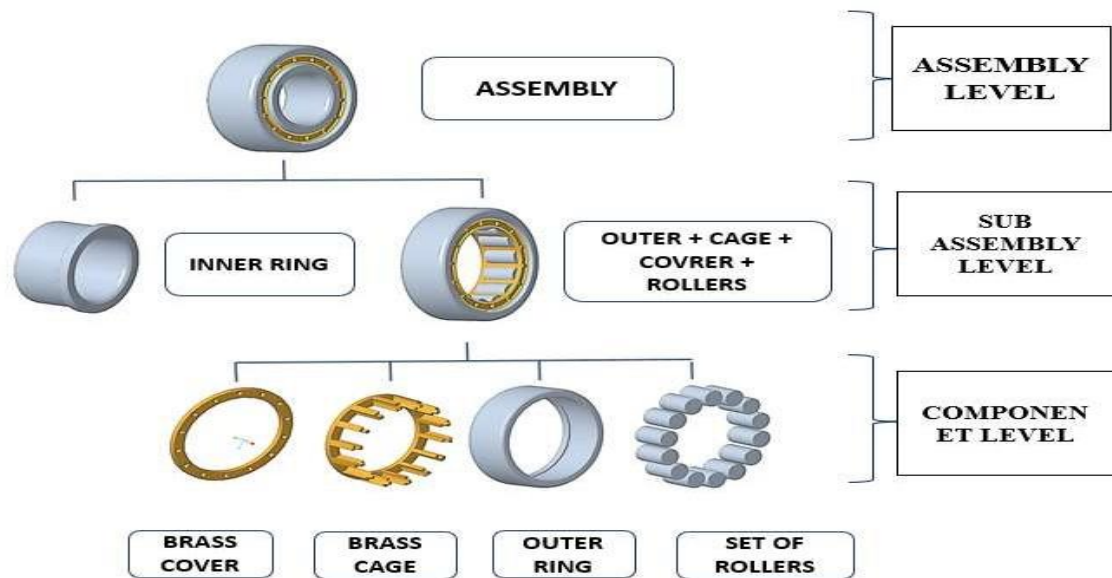

Figure 6 Bearing Assembly Stages

Conventional locking Process to permanently join or fasten two or more components together resulting in a part that cannot be disassembled. There are many reasons to choose permanent assembly including safety, extreme operating forces, regulatory laws, industry standards, or the use of the part as a component in another assembly

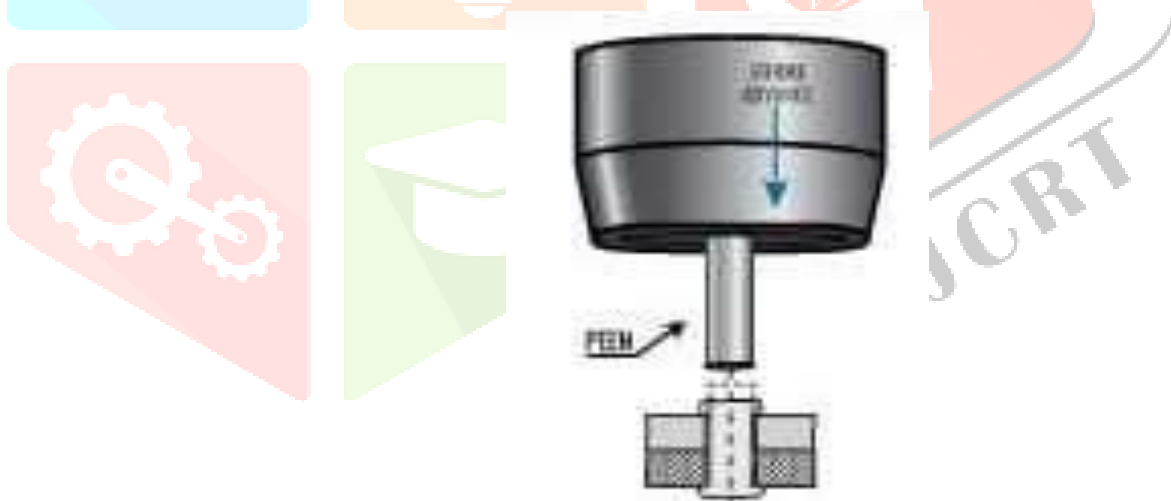

Figure 7 Conventional Permanent Assembly Process

Pressing uses force to close the brass cage & its cover components together. Rivets are often automatically fed through the components into the lower tooling to form the other end, securing the components together. The advantage of pressing is that the cycle time is typically less than one second.

Orbital Spin Riveting machines have a spinning forming tool (known as a peen) which is gradually lowered into the rivet which spreads the material of the rivet into a desired shape depending upon the design of the tool. Orbital forming machines offer the user more control over the riveting cycle but the trade-off is in cycle time which can be 2 or 3 seconds.

There are different types of riveting machines. Each type of machine has unique features and benefits. The orbital riveting process is different from impact riveting and spiral form riveting. Orbital riveting requires less

downward force than impact or spiral riveting. Also, orbital riveting tooling typically lasts longer.

Orbital riveting machines are used in a wide range of applications including brake linings for commercial vehicles, aircraft, and locomotives, textile and leather goods, metal brackets, window and door furniture, latches and even mobile phones. Many materials can be riveted together using orbital riveting machines including delicate and brittle materials, and sensitive electrical or electronic components.

The orbital riveting process uses a forming tool mounted at a 3 or 6° angle. The forming tool contacts the material and then presses it while rotating until the final form is achieved. The final form often has height and/or diameter specifications.

Pneumatic orbital riveting machines typically provide downward force in the 1,000–7,500 lb. (450–3,400 kg) range. Hydraulic orbital riveting machines typically provide downward force in the 6,000–50,000 lb. (2,700–22,700 kg) range.

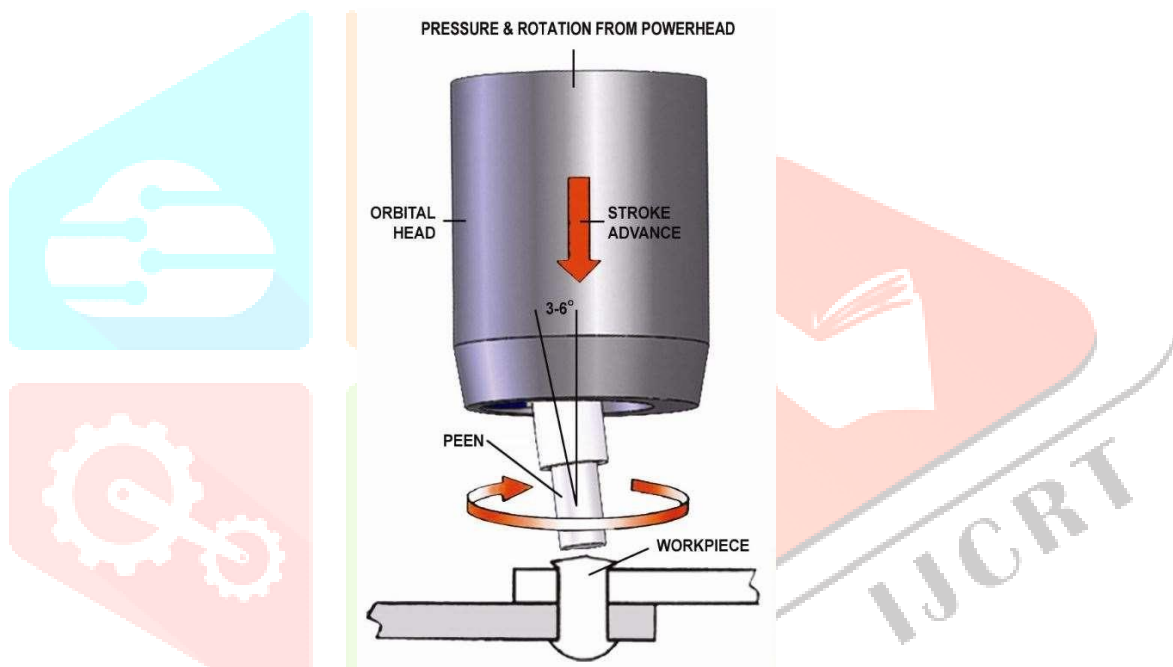

Figure 8 Diagram of how an orbital riveting works

1.9 Challenges in Existing Process:

1. Conventional Brass cage riveting facility was not giving desired results.
2. High customer complaint due to Rivet locking issues.
3. Loss of business.
4. In-house components rejection during assembly stage
5. Tool setup time was high in Pressing Mechanism
6. Electricity consumption is 3.73kW/hour in pressing Mechanism (5 H.P. motor is required)

To overcome above said issues our CFT (Cross functional team) decided to close/join the brass cage and its cover by using orbital spin riveting technology which requires less force to join the cage and cover.

The graph shows the rejection percentage details during bearing assembly stage due to pressing mechanism,

Graph 1 : Rejection details before developing riveting machine

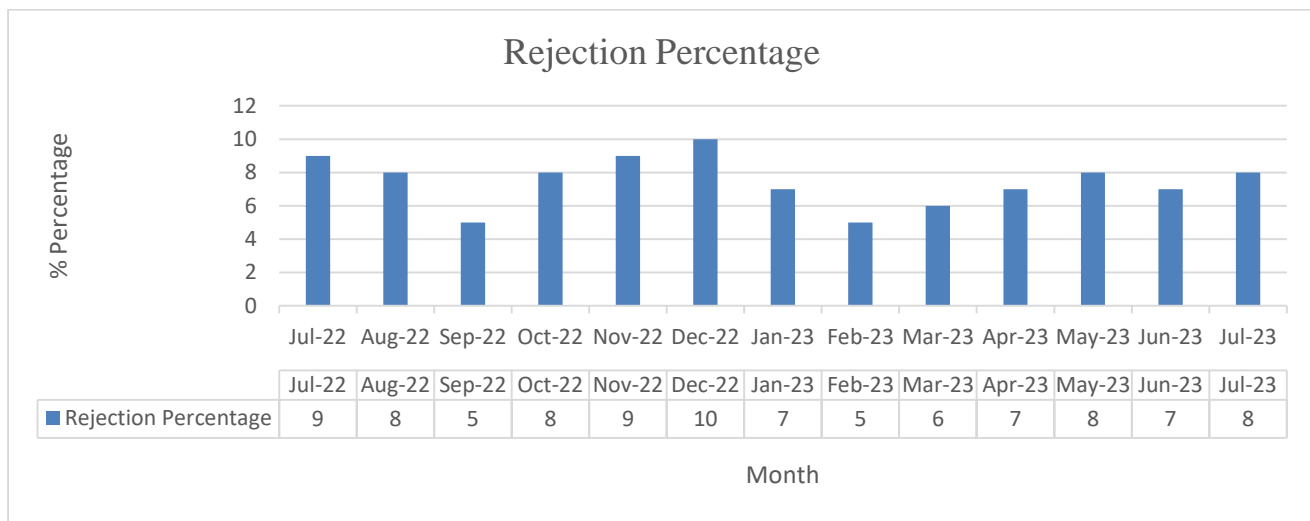

1.10 P-D-C-A cycle

The methodology can be applied to any subject or problem. It is a vehicle to carry the project from inception to conclusion. The ultimate goal of Kaizen strategy and activities aim at improving Quality, Cost, and Delivery (QCD), thus QCD target has become a top priority for survival in business. As per the study for cost reduction activity for Pillow Block productivity improvement. The Kaizen is being planned to achieve the goal. For that following methodology is adopted.

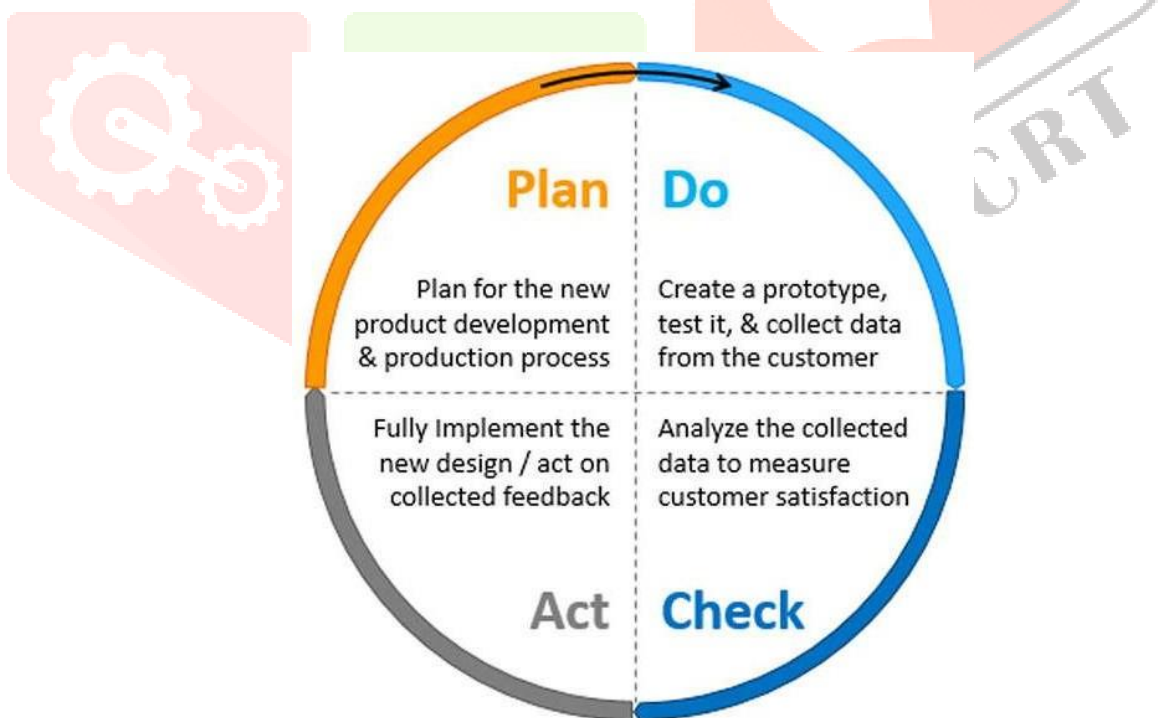

Figure 10- PDCA Cycle

P- Plan: Define the problem and prepare for study is to be conducting. How it is done: -CFT team is forming for identify the scope in productivity improvement in Pillow block Bearing. The targets for improvement and evaluation factors are collected while building cohesion among team members and found the SEAL CAP manufacturing needs more process time on the 60 Tone thus the unit cost of CAP increasing & it is became major obstacle to meet the customer demand due to its higher process time. Thus, we did Collection of

operation standards (ISO 9001:2000 & TS 16494) of above press parts from production department. All the relative information were mentioned in BOM and operation standard.

D – DO: Apply the technique by filtering ideas coming out in brain storming sessions, and finalizing the work schedule. How it is done: - For 60T machine the improvement of productivity is depends on reducing number of dies change, improve production strokes per minute SPM and improve overall equipment efficiency (OEE) for which the press partreinforcement cab stay is production process is examine under the scheduled tool trial. The results of tool trial and quality check are noted. Calculation of total cost saving during productivity improvement.

C-Check: Monitor the results How it is done: - Check the 5 sample parts after each operation and compare with standard part and operation standard. The machine parameters are observed during the trial time. The results are calculated on the basis of different criteria.

A-Act: Standardize the process How it is done: - Document the results and prepare the presentation for management approval.

1.11 TPM – Total Productive Maintenance

Manufacturing is considered to be an important element in a firm's endeavor to improve firm performance (Skinner, 1982; Hayes & Wheelwright, 1984). Superior manufacturing performance leads to competitiveness (Leachman et al., 2005). TPM is a highly structured approach, which uses a number of tools and techniques to achieve highly effective plants and machinery. With competition in manufacturing industries rising relentlessly, TPM has proved to be the maintenance improvement philosophy preventing the failure of an organization (Eti et al., 2006). Today, an effective TPM strategy and programs are needed, which can cope with the dynamic needs and discover the hidden but unused or under-utilized resources (human T Global Journal of Researches in Engineering Volume XII Issue VI Version I 25 (G) brainpower, man-hours, machine-hours). TPM methodology has the potential to meet the current demands. A well-conceived TPM implementation program not only improve the equipment efficiency and effectiveness but also brings appreciable improvements in other areas of the manufacturing enterprise. Cuticulum et al. (2001) have stated that equipment is the major contributor to the performance and profitability of manufacturing systems. Seth & Tripathi (2005) have investigated the strategic implications of TQM and TPM in an Indian manufacturing set-up. Thun (2006) has described the dynamic implications of TPM by working out interrelations between various pillars of TPM to analyze the fundamental structures and identifies the most appropriate strategy for the implementation of TPM considering the interplay of different pillars of this maintenance approach. Ahuja & Khamba (2008a) have investigated the significant contributions of TPM implementation success factors like top management leadership and involvement, traditional maintenance practices and holistic TPM implementation initiatives, towards affecting improvements in manufacturing performance in the Indian industry The goal of TPM is the continuous improvement of equipment effectiveness through engaging those

that impact on it in small group improvement activities. Total quality management (TQM) and total productive maintenance (TPM) are considered as the key operational activities of the quality management system. In order for TPM to be effective, the full support of the total workforce is required. This should result in accomplishing the goal of TPM: "Enhance the volume of the production, employee morals, and job satisfaction."

The main objective of TPM is to increase the Overall Equipment Effectiveness (OEE) of plant equipment. TPM addresses the causes for accelerated deterioration and production losses while creating the correct environment between operators and equipment to create ownership. PQCDSM – The Six Dimensions of TPM Implementation

The mnemonic, PQCDSM is a vital tool in TPM implementation, with each word acting as an indicator of operational efficiency. PQCDSM means Productivity, Quality, Cost, Delivery, Safety and Morale

Productivity (P) is concerned with the utilization of production hours. Low productivity output is as a result of material shortage, manpower issues, and tools etc. One of the important metrics in TPM is OEE which means overall equipment efficiency. According to TPM standards, minimum 85% OEE must be attained. Therefore, it means minimum 85% productivity must be attained as one of the three factors of OEE.

Quality (Q) Another key consideration of OEE is Quality. It is the second part of PQCDSM. This implies zero customer complaints which can be achieved by minimizing rejection and rework, through getting things right the first time. From the point of view of the customer, it means that there should be no returns.

Costs (C) The third part of PQCDSM is Cost. It focuses on reducing manufacturing cost by some percentage. Manufacturing cost is reduced by minimizing production and maintenance expenses, inventory cost and communication-related cost etc.

Delivery (D) part of the PQCDSM stands for Delivery which focuses on delivering products on time to the customer. A best practice is ensuring that delivery rate is 100%. It can be attained by reducing the time in logistic losses, time in supply to any of the support functions.

Safety (S) is the fifth tool of PQCDSM which stands for Safety. It focuses on having zero accident or accident-free zone area by ensuring the safety of workers on machines, safety in material handling, packaging, etc.

Morale (M) is the last PQCDSM tool. In order to enhance employees' motivation, they are to involve in doing a number of challenging continuous improvement activities. This also incorporates the organization of autonomous maintenance teams so that better cohesion and teamwork are encouraged.

1.12 Techniques of TPM

A variety of tools and techniques are applied by manufacturing companies to assist in the deployment of TPM programmes and activities. Some of the tools employed to analyze and solve equipment and process related

problems include but not limited to the following: Pareto Analysis, One Point Lessons (OPL), 5S Practice, Kaizen (Continuous Improvement), Autonomous Maintenance, Poka-yoke, and Overall Equipment Effectiveness.

Table 1 – Tools and Techniques of TPM

TMP Tools	Purpose	Description
5S Practice	Reduces time wastage and motion level	Organized approach to housekeeping that ensures tools, parts and other objects are in known, optimum locations
Poka yoke	Prevents the occurrence of mistakes or defects	Uses a wide variety of ingenious devices to prevent mistakes. An example is an automotive gasoline tank cap that has an attachment that prevents the cap from being lost.
One Point Lesson	To provide immediate, visual information that enables people to make correct decisions and manage their work and activities.	One point lesson uses a wide variety of signs, signals and controls, to manage people and processes.
Autonomous Maintenance	To provide personal care of equipment by the operator.	The operator of the equipment haven understood the functions of the equipment, does activities like cleaning, lubricating, dusting and inspection. This helps to prevent sudden breakdown of the machine and also give the operators the sense of ownership of the equipment
Root Cause Analysis	Tackles production problems at the base level	When root causes are eliminated, breakdowns of equipment are reduced, which would reduce the downtime of machine and ultimately increase the Overall Equipment Effectiveness (OEE).
Kaizen (Continuous Improvement)	Institutionalizes the practice of achieving small daily improvements and improvement of overall efficiency.	Continuous Improvement refers to the idea that a large number of small improvements in processes are easier to implement than major improvements that have a large cumulative effect.

Pareto Analysis: Pareto Analysis is a statistical tool that is used in decision-making, and for the selection of a limited number of tasks that produce significant overall effect. It uses the Pareto Principle (also known as the 80/20 rule), the idea is that by achieving 20% of the work one can generate 80% of the benefit of doing the entire job. Take quality improvement for example, a vast majority of problems (80%) are produced by a few key causes (20%). This TPM tool and technique is also called the vital few and the trivial many, as the 20% of a systems defect can cause 80% of its problems. After the identification of the defects, TPM applies the root cause effect to correct the defects. As a lean tool the Root cause analysis is used to identify the root causes of problems so that the problems can be eliminated at their base level. Root causes of equipment breakdowns can be analyzed when it has been detected and corrective measures can be suggested, so as to reduce or eliminate the root causes (which could be very minor at that level). If root causes are eliminated, breakdowns of equipment would reduce leading to the reduction of the downtime of machine, and ultimately increase the Overall Equipment Effectiveness (OEE).

One Point Lessons (OPL): An OPL is a five to ten minutes self-study lesson which is visual in nature, drawn up by team members and covers a single aspect of equipment or machine structure, function, or method of inspection. One-point lessons are one of the most powerful tools for transferring skills. The teaching technique helps employees to learn a specific skill or concept in a short period of time through the extensive use of visual images. The skill being taught, is typically presented, demonstrated, discussed, reinforced, practiced, and documented in thirty minutes or less. Robinson and Ginder (1995), noted that Single-point lessons are especially effective in transferring the technical skills required for a production operator to assume minor maintenance responsibilities. They explained that team activities in TPM are usually conducted by teams known as small group activity (SGA). A small group is any cross-functional work team charged with working together to improve plant performance by solving problems and managing specific plant areas, machines, or processes. TPM SGA's does not operate independently, but rather perform TPM activity consistent with the overall TPM plan.

5S Practice is based on Japanese method of establishing and maintaining an organized and effective workplace is often used during plant cleaning activities. It is a systematic method to organize, order, clean, and standardize a workplace. The elements of 5S practice are:

- Seiri (sort)
- Seiton (set in order)
- Seiso (shine)
- Seiketsu (standardize) and
- Shitsuke (sustain)

Table 2: Key Activities for Effective 5S Implementation

Japanese term	English 5S	Features
Seiri	Sort	Sort out unnecessary items from the Workplace and remove them
Seiton	Set in order	Put necessary items in a good order so that they can be easily picked up when needed
Seiso	Shine	Clean the shop floor thoroughly to make it free from dust, dirt and oil spillage
Seiketsu	Standardize	Maintain high standard of shop floor and workplace organization
Shitsuke	Sustain	Train and motivate people to follow good housekeeping disciplines autonomously

Kaizen (Continuous Improvement) Also known as continuous improvement; Kaizen translated from Japanese language mean good change. It is a systematic TPM tool and technique that seeks to achieve small

and gradual change in manufacturing process so as to improve efficiency and quality.

Autonomous Maintenance: is the first step in TPM implementation by manufacturers have the capacity for equipment improvement, as it leads to the stoppage of unnecessary equipment breakdown. As an extraction of 5S activities of the production team, it helps to prevent sudden breakdown by the machine and give the operators a sense of ownership of production equipment

Poka Yoke (Error Proofing)

As errors and mistakes are bound to happen in the shop floor, poka yoke which are simple and inexpensive devices are applied to checkmate the occurrence of such mistakes which lead to the manufacturing of defective products. Benhabib (2003), explained that poka yoke involves the use of devices and procedure that would prevent the assembly of wrong components and subassemblies. With its application the operators are able to do self-checking when production is on-going, by stopping production processes whenever an error is detected, thereby ensuring that a defective product does not pass through. This ensures the attainment of one of the goals of TPM which is defect free production. Table 2 illustrates some of the tools and techniques of TPM that are applied to improve quality and productivity and also reduce equipment breakdown.

2. Literature Review

2.1 Literature Summary

Before starting our work, we had viewed many research papers which indicates that for a production-based industries machine installation is a crafty and skillful task as many factors are associated with it such as power consumption, time required, maintenance cost, no of units produced per machine etc. Some research papers which led us an idea are as follows:

Dharwad Chaitanya Kirti Kumar

DESIGN & FABRICATION OF HUMAN POWERED MULTI-PURPOSE MACHINE

(Vol.1, Issue.1, ISSN:2347-4718) (2013)

Author designed and developed a multipurpose machine which does not require electricity for several operations like cutting, grinding etc. This is a human powered machine runs on chain drives mainly with human efforts. But if you wanted to operate this machine by electric power this machine can also does that. It has some special attachment so use both human power as well as electric power. The design is ideal for use in the developing world because it doesn't require electricity and can be built using metal base, chain, pulley, rubber belt, grinding wheel, saw, bearing, foot pedal, electric motor, chain socket.

Rakesh Ambade

DESIGN & FABRICATION OF HUMAN POWERED MULTI-PURPOSE MACHINE

(Volume No 03, Special Issue No. 01, April 2015 ISSN (online): 2348 – 7550)

Developed a conceptual model of a machine which would be capable of performing different operation

simultaneously, and it should be economically efficient. This machine can be used in remote places where electricity is irregular or insufficient. It is designed as a portable one which can be used for cutting in various places. The material can be cut without any external energy like fuel or current. Since machine uses non-electric power and fuel, this is very cheap. Energy is the most vital aspect in the development of modern technological civilization. In the present work, a human powered multipurpose machine is developed which can perform three types of operations drilling, sawing and grinding. Power required for pedaling is well below the capacity of an average healthy human being. The system is also useful for the work out purpose because pedaling will act as a health exercise and also doing a useful work.

Sharad Srivastava

Developed a conceptual model of a machine which would be capable of performing different operation simultaneously, and it should be economically efficient. In this machine we are actually giving drive to the main shaft to which scotch yoke mechanism is directly attached, scotch yoke mechanism is used for sawing operation. On the main shaft we have use bevel gear system for power transmission at two locations. Through bevel gear we will give drive to drilling center and grinding center. The model facilitates us to get the operation performed at different working center simultaneously as it is getting drive from single power source. Objective of this model are conservation of electricity (power supply), reduction in cost associated with power usage, increase in productivity, reduced floorspace.

Dr. Toshimichi Moriwaki

(“Trends in Recent Machine Tool Technologies” - NTN Technical Review No.74(2006))

Recent trends in the machine tool technologies are surveyed from the viewpoints of high speed and high-performance machine tools, combined multifunctional machine tools, ultra-precision machine tools and advanced and intelligent control technologies. Frankfurt am Main, 10 January 2011: The crisis is over, but selling machinery remains a tough business. Machine tools nowadays have to be veritable “jack of all trades”, able to handle all kinds of materials, to manage without any process materials as far as possible, and be capable of adapting to new job profiles with maximized flexibility. Two highly respected experts on machining and forming from Dortmund and Chemnitz report on what’s in store for machine tool manufacturers and users. Multi-purpose machines are the declarations of independence. The trend towards the kind of multi-purpose machining center’s that are able to cost efficiently handle a broad portfolio of products with small batch sizes accelerated significantly during the crises. “With a multi-purpose machine, you’re less dependent on particular products and sectors”, explains Biermann.

Guanci Chen - October 30, 2012

Effects of raceway roundness and roller diameter errors on clearance and runout of a cylindrical roller bearing

The actual radial clearance and runout of the bearing are different from design ones, because of the unavoidable raceway roundness and roller diameter errors of a cylindrical roller bearing. However, there is little knowledge about how the raceway roundness and roller diameter errors affect the radial clearance due to the lack of the

analysis method. In this study, a mathematic model with algebraic equations is developed. The raceway curves are described by Fourier series. When the outer ring is turned an angle, iterative calculations are done until at least one roller contacts the raceways by judging whether the clearances between the rollers and inner raceway equal zero or not. Then the radial clearance and runout of the bearing can be determined when the outer ring is turned one revolution. The independent and synthetic effects of the raceway roundness and roller diameter errors on the radial clearance and runout of a cylindrical roller bearing are analyzed. Results show that the clearance and runout periodically vary with the increase of the flap number, which is also the harmonic number, of the rotating raceway. The ratio of the numbers of the raceway flaps and rollers determines the period. The clearance and runout of a cylindrical roller bearing are greatly affected by the rollers' diameter errors instead of their positions.

3. Problem Statement and Objectives

3.1 Problem Statement

In the conventional assembly process of pillar pressing causes less material deformation and chances of cage-cover disassemble are more and also rapid increase in the Quality complaints, bearing rejections while achieving increasing production demand.

To overcome these issues demands a special purpose devices or attachment to existing set up.

3.2 Objective

Studying existing conventional bearing assembly process used to lock the bearings To develop new equipment which is:

1. Free from Losses
2. Easy to Maintain
3. Easy & Safe to Operate
4. Free from Defects & Unnecessary Cost
5. Having Vertical Start up (Rapid Stabilization for Mass Production)
6. Calculate payback time of designed machine

Table 3 Objective

Sr.No.	Parameters	Action	Benefits	Attribute
1.	Customer Complaints	Development of Riveting Machine	Zero Customer Complaints	Quality

2.	Lack of Process capability		Riveting of large size Cages possible	Operability
----	----------------------------	--	---------------------------------------	-------------

4. Methodology

In this case study, The Orbital Riveting M/C is made for locking operation of CRB. In this project the following studies are carried out

New Equipment Name: Orbital Spinn Riveting machineLine: Assembly					
ResultArea	Parameter		U.O.M	Benchmark	Target (Achieved)
P	Operability	Setup change/Occ	Min.	0.85	0.80
		Measurement. & Adjustment Loss	Min.	Nil	Nil
Q	Quality	Defects due to Equipment	PPM	Nil	Nil
C	Cost	Energy Consumption/piece	kW	1	0.746
		Total cost/piece	Rs.	9	6
D	Delivery	Lead Time (Requirement to Commissioning)	Days	6	6
		Time Reduction in OEE Stabilization	Days	10	9

- Time saved by component handling (loading and unloading),
- Increase in productivity both qualitative and quantitative,
- Less human intervention, indirectly reduction in operator fatigue,
- Less rejection due to automatic controls, and
- Increase the profit of company.
- Manufacturing Range Extension

As we know, any product is made of different parts used to perform the desired function. The cost of that product includes cost of all parts used inside it. The profit maximization is depending on cost reduction and there are many ways to reduce unwanted cost of product or process. The price of parts is depending on their cost of manufacturing. If we analyze the scope of cost reduction in these parts, then it can improve the overall profit of that product.

The above thought was encouraged me to conduct a study in manufacturing process to find out the scope in cost reduction comparing with the cost reduction techniques used in manufacturing industries.

4.1 Development Flow Chart (Strategy)

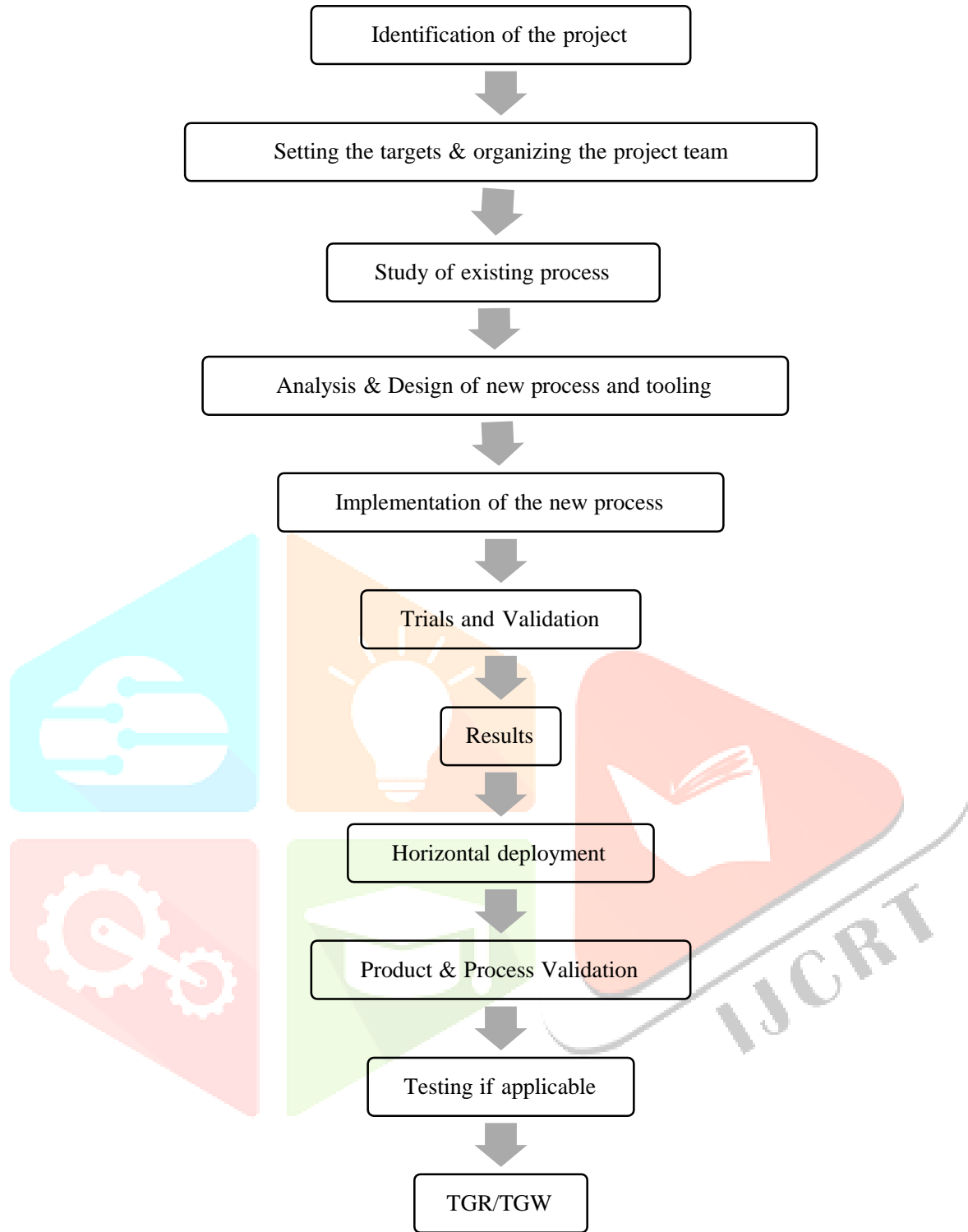

Figure 9 - Methodology

4.2 Master Plan for Equipment development

Table 4: Masterplan of New Equipment development

MASTER PLAN OF NEW EQUIPMENT DEVELOPEMENT													
Steps	Activities	2022-23											
		Dec-22	Jan-23	Feb-23	Mar-23	Apr-23	May-23	Jun-23	Jul-23	Aug-23	Sep-23	Oct-23	Nov-23
Step-1	Pre-Planning												
Step-2	Planning & program definition												
Step-3	Equipment design & development												
Step-4	Assembly Process Design & development												
Step-5	Equipment & Process Validation												
Step-6	Feedback and corrective actions												
Step-7	Horizontal Deployment												
Step-8	Continual Improvement												

4.3 DESIGN PROCEDURE

Design consists of application of scientific principles, technical information and imagination for development of new or improvised machine or mechanism to perform a specific function with maximum economy & efficiency. Hence a carefully design approach has to be adopted.

□ System design

In system design we mainly concentrated on the following parameters: -

1. System Selection Based on Physical Constraints -While selecting any machine it must be checked whether it is going to be used on regular basis or not. In our case it is to be used on regular basis. So, space is a major constraint. The system is to be kept very compact so that it can be adjusted on smaller area.
2. The mechanical design has direct norms with the system design. Hence the for most job is to control the physical parameters, so that the distinctions obtained after mechanical design can be well fitted into that.
3. Arrangement of Various Components- Keeping into view the space restrictions the components should be laid such that their easy removal or servicing is possible. More over every component should be easily seen none should be hidden. Every possible space is utilized in component arrangements.
4. Components of System -As already stated the system should be compact enough so that it can be

accommodated at a corner of a room. All the moving parts should be well closed & compact. A compact system design gives a high weighted structure which is desired.

5. Man Machine Interaction- The friendliness of a machine with the operator that is operating is an important criterion of design. It is the application of anatomical & psychological principles to solve problems arising from Man – Machine relationship.

6. Servicing Facility- The layout of components should be such that easy servicing is possible. Especially those components which require frequent servicing can be easily disassembled.

7. First time right- The design must be first time right, Factor of safety while doing mechanical design is kept high so that there are less chances of failure. More over periodic maintenance is required to keep unit healthy.

8. Scope of Future Improvement- Arrangement should be provided to expand the scope of work in future. Such as to convert the machine motor operated; the system can be easily configured to required one. The die & punch can be changed if required for other shapes of notches etc.

9. Height of Machine from Ground-For ease and comfort of operator the height of machine should be properly decided so that he may not get tired during operation. The machine should be slightly higher than the waist level, also enough clearance should be provided from the ground for cleaning purpose.

4.4 COMPONENT OF ORBITAL RIVETING MACHINE

The system should be compact enough robust so that it can be accommodated at a smaller floor area. All the moving parts should be well closed & compact. A compact system design gives a high weighted structure which is desired.

1. Frame: is the basic structure of the machine on to which entire assembly of machine is made. It is made of Mild steel.

2. 3-Phase Induction motor: is used in the machine is 3-phase induction motor, Power-1 Hp, Speed-1420 rpm, Foot mounted.

3. Spindle: is a high-grade steel (En24), The spindle carries the spindle pulley at the top end whereas the tool holder at the bottom end. The spindle runs at high speed 960 rpm.

4. Top Spindle housing: It is rectangular element made from structural steel. En9, bolted to the machine frame. It carries the single row deep groove ball bearing 6305-2RS.

5. Ball Bearings: The spindle locates at the top and bottom ends in single row deep groove ball bearing 6305-2rs. Internal & external diameter of bearing is 25mm & 62mm. the width of bearing is 17mm.

6. Tool Locking Device: It is high grade steel member (En24), held to the spindle at the lower end. The device holds the rivet set (tool) at an angle 5°, to the spindle axis.

7. Rivet Tool: The rivet tool is a hardened steel component OHNS. The rivet set is provided with cavity at its

lower end according to shape of the rivet head to be formed. It is placed at an angle 50, to the spindle axis and is held in the tool holder. It is basically a fixture to hold the job while carrying out the riveting operation. The work holder is held on the work table.

8. Servo Motor: provide accurate positioning for quick moves such as indexing. All feature a closed loop configuration ideal for variable loads and offer a wide range of gear options and braking or load holding options. The built-in controller (stored data) FLEX also helps for system configuration considerations.

9. Linear Bearings: Blocks provides smooth and quiet motion in linear direction to the work block; Linear guideways provides linear motion by re-circulating rolling elements between a profiled rail and a bearing block. The coefficient of friction on a linear guideway is only 1/50 compared to a traditional slide and they are able to take loads in all directions. With these features, a linear guideway can achieve high precision and greatly enhanced moving accuracy.

10. Work table: is made from structural steel (En9), it is basically a table to hold the work holder while carrying out the riveting operation. The work table is held on the Table slide.

11. Slide guide Plate: is made from structural steel (En9), it is basically a guide to hold the Table slide while it moves forward or reverse while carrying out the riveting operation. The Table guide is bolted to the machine frame.

12. Index Plate: is made from structural steel (En9), it is basically a table to hold the part locating while carrying out the riveting operation. The Index Plate is held on the work table is index with the help of servo motor.

13. Work-Piece Locating Plate: is made from structural steel (EN31), it is basically a resting plate to hold the part locating while carrying out the riveting operation.

14. Locking Cylinder Assembly: is made from structural steel (EN31), it is used to lock the motion of indexing plate while carrying out the riveting operation.

15. Feed handle: is mounted in the handle hinge; it carries the roller at one end and the know about another end. It moves the table slide up or down when operated.

16. Safety Light Curtain: it protects personnel from injury and machines from damage by creating a sensing screen that guards machine access points and perimeters. They are intuitive, easy-to-use safety light curtains for a wide variety of safety.

17. Tower light with buzzer: Light tower audible combinations provide a visual signal as well as an audible sound, such as a buzzer, to warn of danger or to draw attention to an important aspect in a work environment. They are particularly useful in busy workplaces where loud noise is a factor, enabling workers to be aware of any potential danger

18. Operator Panel: With the Operator Panel, we can monitor, configure, and operate library functions from the library front panel. The Operator Panel has a Power button, an LCD display, six navigation buttons, and

five LEDs.

19. Two Hand Push Button: control panels are protection devices, which require the simultaneous use of both hands for their actuation. By virtue of their forced location, both hands are kept out of the area of danger.

4.5 WORKING OF ACTUAL MACHINE

Following steps need to be carried out to complete the riveting cycle

1. Load the component on locating plate
2. Slide the slide plate manually and lock it with the manual locking assembly and locking block
3. Press the two-hand push button
4. Servo motor index and takes its position
5. Locking Cylinder assembly lock the index plate
6. Riveting machine come down, Pressure pad press the component and riveting will perform
7. riveting machine goes up, locking cylinder unlock the index plate.
8. Servo motor index again to take new riveting position and repeat all sequence again and again till complete all riveting operations are carried out.
9. Then unlock the slide plate using manual locking and slide it to loading position.
10. Unload the finished component and load another component which is to be riveted

4.6 MANUAL CALCULATIONS

8.1 Example 1:

For NJ2312 Cylindrical Roller Bearing

As per the requirement of the use machine has been designed for its first bearing type **NJ2312** Cylindrical Roller Bearing,

Δ = mean thickness of deforming zone / length of deforming zone

$$\Delta = h/2L$$

$$\Delta = 4/2(4) = 0.50$$

$$\Delta = 0.500$$

$$C = 0.8 + 0.2 \Delta$$

$$= 0.8 + 0.2 (0.500) = 0.900$$

Where, C = Constant (Constraint factor) = 0.900

$$\sigma = \text{mean flow stress} = 120\text{N/mm}^2$$

$$A = \text{Forging projected area; mm}^2$$

$$= \{\pi/4 \times (D^2 - d^2) - (F^2)\} / 13$$

$$= 7.06 \text{ mm}^2$$

$$P = \sigma A C$$

$$= 120 \times 7.06 \times 0.90$$

$$= 762.48\text{N}$$

Most of the work during orbital forming is focused at the tool's line of contact, not along the entire tool surface. This reduces axial loads by as much as 80%, which has several advantages.

Hence,

$$P_{\text{uff.}} = 0.2 \times 762.48 = 152.496\text{N}$$

$$P_{\text{eff.}} = 152.496 \text{ N}$$

This is the load that acts in the downward direction while forming the rivet, whereas the rivet head diameter is 6mm, hence the torque required at the spindle is given by:

$$T = P_{\text{eff.}} \times r$$

$$= 152.496 \times 3$$

$$= 457.488 \text{ N-mm}$$

$$T = 0.457 \text{ N-m}$$

Power required at spindle is given by,

$$P = 2 \pi N T / 60$$

$$= 2 \pi \times 900 \times 0.457 / 60 = 43.15 \text{ watt.}$$

$$P = 43.15 \text{ watt.}$$

DESIGN OF MAIN SPINDLE.

Torque Analysis: -

Torque at spindle is given by;

$$T_s = 975 \Delta / n$$

$$T_s = 975 \times 0.375 / 1440$$

$$T_s = 0.253 \text{ kg .m}$$

$$T_s = 2.53 \text{ Nm}$$

Considering 25 % overload;

$$\text{Design} = 1.25 T_s$$

$$= 1.25 \times 2.53$$

$$= 3.10 \text{ Nm}$$

$$\text{Design} = 3.10 \text{ Nm}$$

Planning a 1 stage transmission

Spindle transmission speed = 1440 rpm

$$\text{Spindle Torque} = \text{Design} \times 1.6 = 3.10 \times 1.6 = 4.973 \text{ N-m}$$

$$\text{Design} = 4.973 \text{ N-m.}$$

Ultimate Tensile Strength $\text{N/mm}^2 = 720$

Yield Strength $\text{N/mm}^2 = 600$

Using ASME code of design;

Allowable shear stress; fall is given stress;

$$\text{Fall} = 0.30 \times s_{all} = 0.30 \times 600 = 180 \text{ N/mm}^2$$

$$\text{Fall} = 0.18 \times S_{all} = 0.18 \times 720 = 130 \text{ N/mm}^2$$

Considering minimum of the above values;

$$\text{Fall} = 130 \text{ N/mm}^2$$

As we are providing key way on shaft; Reducing above value by 25%.

$$\text{Fall} = 0.75 \times 130 = 97.5 \text{ N/mm}^2$$

a) Considering pure torsional load; Minimum section on the spindle as per system drawing is 20mm

$$\text{Design} = \pi \times \text{fact} \times d^3 / 16$$

$$\text{fact} = 16 \times T / \pi \times d^3$$

$$\text{fact} = 16 \times 4973 / \pi \times 20^3$$

$$\text{fact} = 3.1659 \text{ N/mm}^2$$

As fact < fall

Spindle is safe under pure torsional load.

8.2 Example 2:

For NJ2317 Cylindrical Roller Bearing

As per the requirement of the use machine has been designed for its first bearing type NJ2317 Cylindrical Roller Bearing,

Δ = mean thickness of deforming zone / length of deforming zone

$$\Delta = h/2L$$

$$\Delta = 6/2(6) = 0.50$$

$$\Delta = 0.500$$

$$C = 0.8 + 0.2 \Delta$$

$$= 0.8 + 0.2 (0.500) = 0.900$$

Where, C = Constant (Constraint factor) = 0.900

σ = mean flow stress = 120N/mm²

A = Forging projected area; mm²

$$= \{\pi/4 \times (D^2 - d^2) - (F^2)\} / 13$$

$$= 11.56 \text{ mm}^2$$

$$P = \sigma A C$$

$$= 120 \times 11.56 \times 0.90$$

$$= 1248.48 \text{ N}$$

Most of the work during orbital forming is focused at the tool's line of contact, not along the entire tool surface. This reduces axial loads by as much as 80%, which has several advantages.

Hence,

$$P_{\text{uff.}} = 0.2 \times 1248.48 = 249.69 \text{ N}$$

$$P_{\text{eff.}} = 249.69 \text{ N}$$

This is the load that acts in the downward direction while forming the rivet, whereas the rivet head diameter is 6mm, hence the torque required at the spindle is given by:

$$T = P_{\text{eff.}} \times r$$

$$= 249.69 \times 3$$

$$= 749.088 \text{ N-mm}$$

$$T = 0.749 \text{ N-m}$$

Power required at spindle is given by,

$$P = 2 \pi N T / 60$$

$$= 2 \pi \times 900 \times 0.749 / 60 = 70.73 \text{ watt.}$$

$$P = 70.73 \text{ watt.}$$

DESIGN OF MAIN SPINDLE.

Torque Analysis: -

Torque at spindle is given by;

$$T_s = 975 \Delta / n$$

$$T_s = 975 \times 0.375 / 2000$$

$$T_s = 0.183 \text{ kg .m}$$

$$T_s = 1.83 \text{ Nm}$$

Considering 25 % overload;

$$\text{Design} = 1.25 T_s$$

$$= 1.25 \times 1.83$$

$$= 2.29 \text{ Nm}$$

$$\text{Design} = 2.29 \text{ Nm}$$

Planning a 1 stage transmission

Spindle transmission speed = 2000 rpm

Spindle Torque = Design \times 1.6 = 2.29 \times 1.6=3.66 N-m

Design = 3.66 N-m.

Ultimate Tensile Strength $\text{N/mm}^2 = 720$

Yield Strength $\text{N/mm}^2 = 600$

Using ASME code of design;

Allowable shear stress; fall is given stress;

$$\text{Fall} = 0.30 \times \text{sall} = 0.30 \times 600 = 180 \text{ N/mm}^2$$

$$Fall = 0.18 \times S_{all} = 0.18 \times 720 = 130 \text{ N/mm}^2$$

Considering minimum of the above values;

$$Fall = 130 \text{ N/mm}^2$$

As we are providing key way on shaft; Reducing above value by 25%.

$$Fall = 0.75 \times 130 = 97.5 \text{ N/mm}^2$$

a) Considering pure torsional load; Minimum section on the spindle as per system drawing is 20mm

$$Design = \pi \times fact \times d^3 / 16$$

$$fact = 16 \times T / \pi \times d^3$$

fact

fact

As

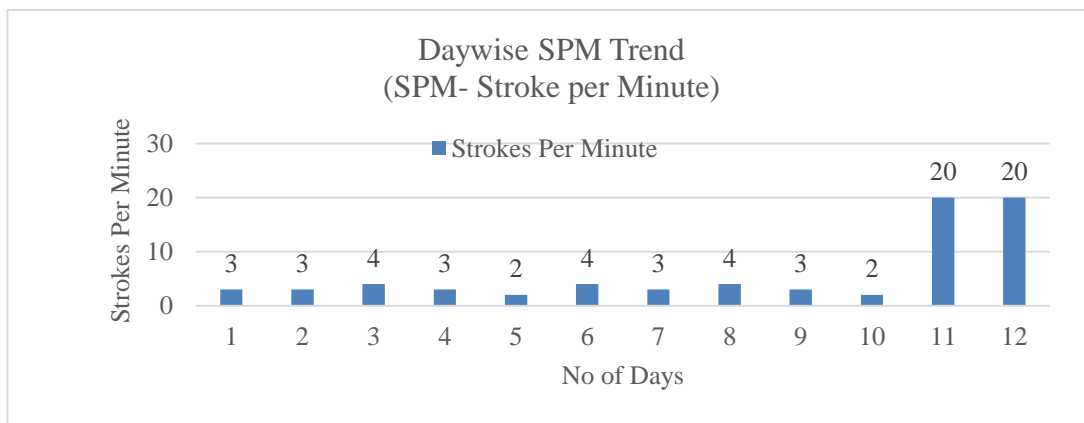

$$= 16 \times 4973 / \pi \times 20^3 = 3.1659 \text{ N/mm}^2$$

fact < fall
Spindle is safe under pure torsional load.

The materials commonly used for cold working orbital riveting rivet materials include:

Low and medium carbon steel.

Low alloy steels

- Copper
- Aluminum

4.7 Cost Analysis: -

NOTE: Per Stroke Cost denoted here as “X” is calculated as per annual budget 2,61,27,360/- (Rs/Annum) } allotted for press shop, which contains all expenditures like Utility (crane, fork lifter, cooling tower, transportation, DG, compressors, Lights/lamps etc.), Salaries/ Wages (operators, helpers, fork lifter driver, line leaders, engineers, press shop In charge, Production managers etc.), Power consumption charges, Machine cost, General Maintenance, tool maintenance (tools, nut bolts,), Housekeeping, miscellaneous charges like lockers, safety shoes, safety goggles, hand gloves, aprons, uniforms, ear plug, stationary etc.)

Graph 2 Day-wise Stroke Trend

Day-wise stroke per minute trend: -

Y axis shows strokes per minute of machine X axis shows no. of days Target SPM 23 The maximum

SPM at 11th day due to kaizen for productivity improvement as per the daily production report the production trend for the day for all press machines in press shop for the day.

The following observations are:

Number strokes for two shifts are 19200

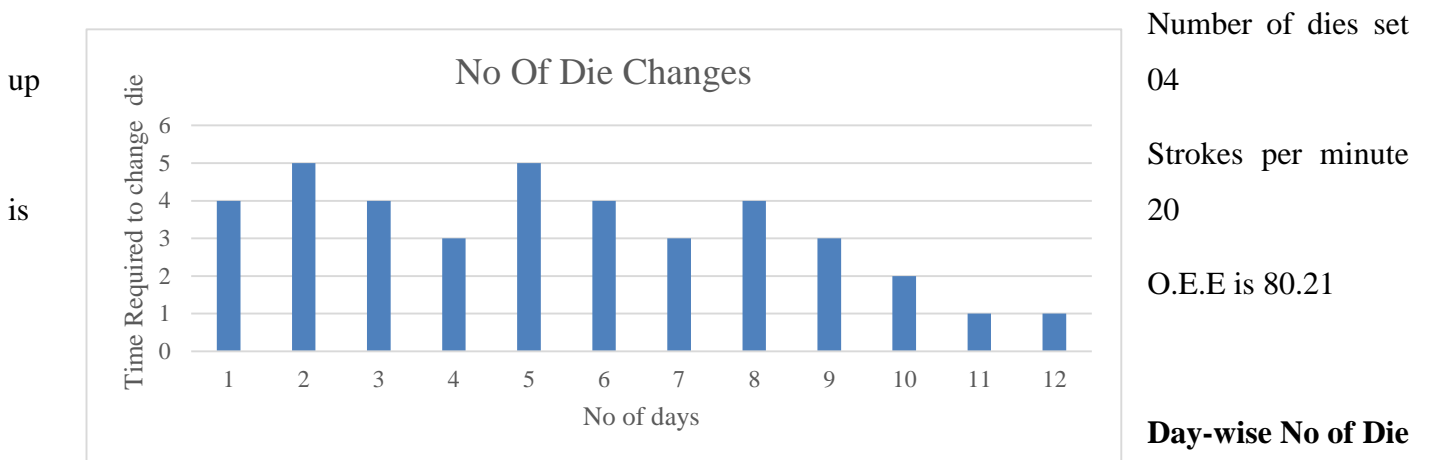

Changes per Trend for Machine: -

Y blue bars shows No of die change & X axis shows no. of days Minimum die change on 11th day due to Kaizen for productivity improvement. Target die change time is 10 min

Graph 3 No of Dies Change for machine

Calculations

Machine specifications

Type: Orbital Riveting Machine

Machine Efficiency = 80%

Stroke length =15mm

Tool's Specifications as per operation standard

Operation details

Manpower required = 03

Approved Cost for operation at Orbital Riveting Machine = Rs 6/stroke

Procedure

“Operation cost is indicated here as number as production strokes of the machine”

Operation cost = approved per stroke cost x annual requirement of parts

$$= 6 \times 12000 = 72000/-$$

Standard tool change time is the time taken during removing of previous operation's tool and uploading next operation's tool die on the machine.

Standard tool changing time = 120 mins

Annual saving in standard tool change time (STCT) = (annual production/lot size) x SDCT

$$= (72000/1000) \times 120 \text{ min} = 8640 \text{ mins}$$

Standard SPM of Orbital

Machine = 16 strokes/min Annual increment in production strokes as per standard SPM of Orbital Machine

= Annual savings in SDCT x Standard SPM of Orbital Machine = $8640 \times 23 = 198720$ production strokes

Annual improvement in production cost

= productions strokes x standard costing of M/c

$$= 198720 \times 6 = 11,92,320/-$$

Total savings in VAVE = Operation cost + Annual improvement in production cost

$$= 72,000 + 11,92,320$$

$$= 12,64,320/-$$

5. Results

5.1 Cycle Time: -

Cycle time is reduced by 5 second for producing a batch of 1000 no's, this means that our process time

improved by 55%.

Graph 4 CYCLE Time

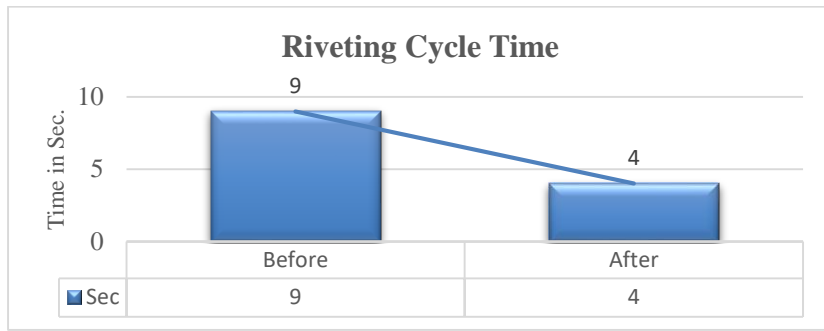

5.2 Tool Set up Time: -

Setting time is reduced by 4.5 hours for producing a batch of 1000nos, this means that our tool set up time improved by 69%.

Graph 5 Tool set up

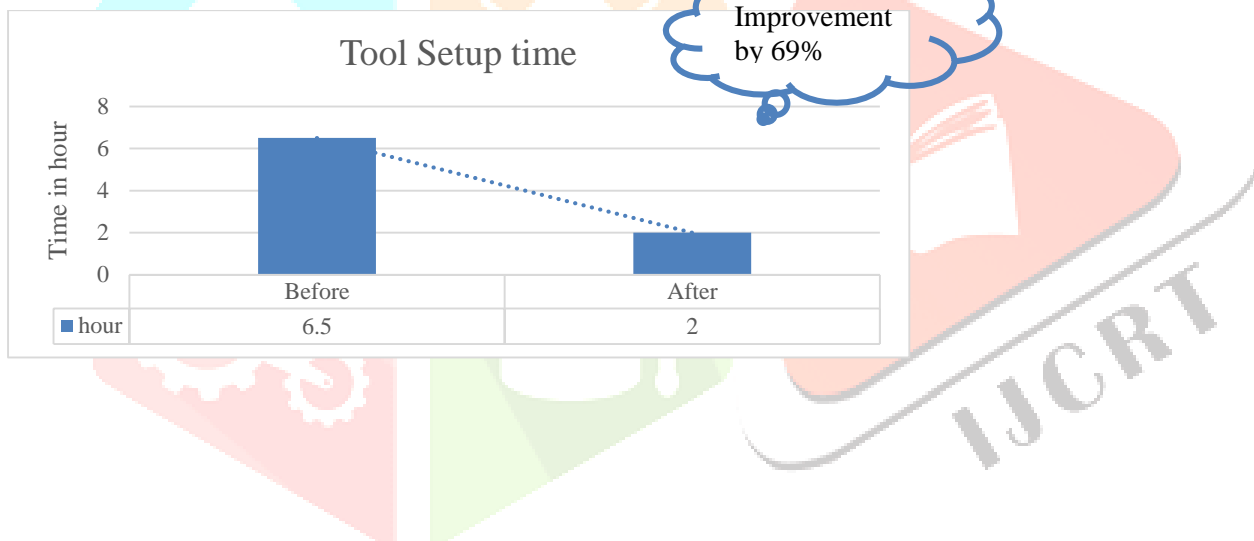

5.3 Electricity Consumption: -

Power consumption is reduced by 2.98kW/hours for producing a batch of 1000nos, this means that our 2.98kW/hour electricity is saved up it is improved by 69%.



Graph 6 Electricity consumption

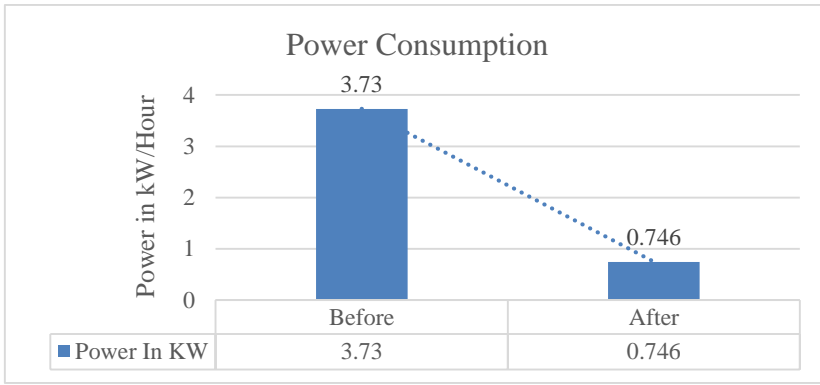
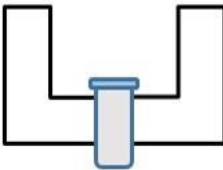
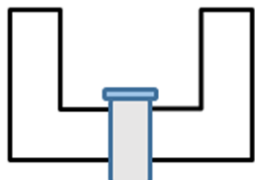
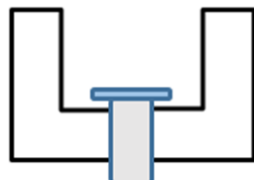

Table 5 Conclusion

Parameter	Issue	Pressing Mechanism (Before)	Flaring Mechanism (After)
Schematic View of riveting		Due to pressing, material deformation is less, and chances of disassemble from cage	Issue resolved due to change in flaring mechanism
Method of locking	Pressing	Not uniform pressing	Uniform pressing
Material Flaring	Locking	No proper locking	Proper locking
Strength	Less strength after locking	Easily separate the cage and cover	Cage and cover don't separate by applying 8T load.

New Equipment Name : Riveting machine model M008		Line : GBD
Assembly		
Parameter	Existing	After
SchematicView of riveting		
Method of locking	Pressing	Riveting

Pullout Load	Less than 10 KN	14 to 20 KN
--------------	-----------------	-------------

5.4 APPLICATION

Since this machine is performing special task, the Special Purpose machine cannot be useful to another location, and due to this reason, the product quality of the company plays important role in market. Also bearing can take more load than specified design load.

6. CONCLUSION

The growth of any manufacturing industry deals with its market demand also the product Quality. With the help of design machine, we can able to achieve the zero-quality defect in large size bearing and customer satisfaction.

After implementation of project model, we got following results through our newly designed Process.

7. FUTURE SCOPE

This study is a specific study restricted to the case. A number of such studies can be done in variety of industries to reach at common conclusions, which can be generalist in nature. There are some more techniques, which can be used in the case organization like technical surveys, weighted score method, decision matrix etc.

As of now the machine is developed as semi-auto basis, due to project investment, thus the we can develop the fully automatic for feeding the work-piece. These will require additional investment.

ACKNOWLEDGEMENT

It is a pleasure for us to present this paper where guidance plays an invaluable key and provides a concrete platform for completion of the paper. We would also like to thank our internal guide Asst. Prof. A. B. Patil Department of Mechanical Engineering, DIEMS for his valuable encouragement and constant scrutiny without which we wouldn't have looked deeper into our work and realized both our shortcomings and our feats. This

work would not have been possible without him. References

- [1] Impact of Cost Control and Cost Reduction Techniques on Manufacturing sector, ISRJ Vol. 3
- [2] Buffa Elwood, Operations Management Johnwiley N.Y. (1976)
- [3] S.M. Sumdaraju, Total quality management, Tata McGraw Hill, New Delhi (1995)
- [4] Witschey, W. & Wulff, R. 2002. How to ensure quality and cut costs with cultural institution value methodology. A case study of value engineering on an history renovation project.
- [5] Womack, J. & Jones, D., "The machine that changed the world: The story of lean production 1991, New York: Harper Collins.
- [6] Bowles. & Hammond, J., "Beyond quality how 50 wining companies use continuous improvement ",1991, New York: Putnam
- [7] Barnes, T., "Kaizen strategies for successful leadership",1996, Pitman Publishing London
- [8] Capital Works Investment: Value Management Manual: New South Wales Government.
- [9] Creswell, J.W. 2003 Research Design, Qualitative, quantity and mixed methods approaches. (2. ed) Thousand Oak: sage publication.
- [10] Cheerer., "Kaizen is more than continuous improvement ", Quality progress, April 1994, pp. 23-26
- [11] Davies, K. E. L. 2004. Finding value in value engineering. Cost Engineering, 46(12):
- [12] Dell 'Isola, A. J. 1988. Value engineering in the construction industry. Washington D. C. Smith Hinchman & Grylls.
- [13] Drury, C. 2000. Management & Cost Accounting (Fifth ed.). London: Business Press Thomson Learning.
- [14] Flyvbjerg, B. 2006. Five misunderstandings about case study research. Qualitative Inquiry, 12(2): 219-245.
- [15] Fong, P. S. W. 1998 a. Value engineering in Hong Kong - A powerful tool for a changingsociety. Computers Industrial Engineers, 35(3/4): 627-630
- [16] Guidebook for VE activities - A basic manual: Society of Japanese Value Engineering.1- 32
- [17] Garvin, D., "Competing on the eight dimensions of quality " ,1987, Harvard Business improvement",1993, New York: Sterling Publishing.
- [18] I.L.O. Introduction to wok study. ILO, Geneva (1979)
- [19] Imai, M., "Kaizen: The key to Japan's competitive success ", 1986, McGraw Hill, [20]Kobayashi, I., "20keys to workplace improvement",1990, Cambridge: productivity press
- [21] Kerzner Harold, A Systems Approach to planning scheduling and controlling Von Nostrand Reinholtony. (1979)
- [22] Knouse, S. B., "The reward and recognition process in total quality management ",1996, Milwaukee, WI: ASQC, Quality Press
- [23] Management Accounting Concepts: International Federation of Accountants.
- [24] Martand Telsang, Industrial Engineering and Production Management, S. Chand & Co., New Delhi. Page 532- 534
- [25] Miles, L. D. 1963. Definitions: Lawrence D. Miles value Engineering Reference Center:Wendt Library.

- [26] Miller, R. & Floricel, S. 2004. Value Creation and games of innovation ResearchTechnology Management: 25-37.
- [27] Mitsufuji, T. 2003. How an innovation is formed: A case study of Japan word processors. Technological Forecasting & Social Change, 70: 671-685.
- [28] P.P. Pandey and C.K. Singh production engineering sciences by standard publisher's distributors nai sarak, delhi 110006 fifth edition 1984 page 500-550
- [29] Sperling, R. B. 2001. Understanding value engineering. IIE Solutions, 33(8): 45-51. [30] Buffa, E.S. and W.H. Taubert, Production Inventory System Planning and Control, IrwinHomewood Illinois.
- [31] Samuel Eilon, Elements of production planning and control Universal Publication, Mumbai (1994)
- [32] Tek, O. H. & Yeomans, P. R. 2002. Value Management: Enhancing project costperformance.

