



FIREFLY OPTIMIZATION ALGORITHM BASED PID CONTROLLER TUNING IN PAPER MACHINE

¹K. RAJASEKHAR, ²K RAJA NAGURU BABU

¹Assistant Professor, ²Student

¹Department of ECE, UCEK (A), JNTU Kakinada

ABSTRACT

In the optimization of the firefly algorithm, the FA algorithm is a meta-heuristics algorithm employed for the tuning of PID parameters k_p k_i k_d using the algorithm. The multi-objective optimization algorithm is used to tune the PID controller parameters by using nature-inspired algorithms and Proportional Integral Derivative controller provides effective results and most of the industrial applications and industrial processes are exact to parameters variations and which provides and the possibility to change the state of unstable and PID controller parameters are tuned for improves the performance and quick response and research present a multi-objective optimization method involving Genetic Algorithm, Particle Swarm Optimization, and Bacterial foraging optimization and performances have been compared with the meta-heuristics Firefly algorithm (FA). The main goal of this study is to develop a multi-objective optimization algorithm real coded PSO PID control self-tuning and optimum for fitness function and then based on the case study. The results show the use of multi-objective optimization comparisons with FA based PID controller-tuning improves the better performance in terms of time-domain specifications and performance index and then based on case study transfer functions taken for simulation using MATLAB and this project shows the comparative approach, proved that better response to tune the PID controller used in the paper machine. From simulations outputs shown that faster and better response results and improves parameters and time domain specifications.

Keywords - Firefly Algorithm, Particle Swarm Optimization, PID Controller

I. INTRODUCTION

Proportional Integral Derivative controller provides effective results and most of the industrial applications and industrial processes are exact to parameters variations. In industrial applications, the PID controller is a common closed-loop control feedback mechanism [1]. The difference between the measured process variable and the desired set point is used to determine the error value.

The proportional, integral, and derivative values are three independent parameters in the PID controller computation and the fundamental purpose of PID controller tuning is to find controller parameters that fulfill the closed-loop system performance standards, and the control loop robustness throughout a wide variety of operating situations should be taken into account. Practically, it is difficult to simultaneously achieve all the desirable qualities. This research presents a multi-objective optimization method involving Genetic Algorithm, Evolutionary Programming, Particle Swarm Optimization, and Bacterial foraging optimization and performances have been compared with the Firefly algorithm (FA).

1.1 Paper Machine

A paper machines purpose is to create paper sheets and remove moisture from them and controls on paper machines strive to maintain quality variables as consistent as possible. Each paper will be assigned a grade, with particular objectives and restrictions. Basis weight, moisture, smoothness, gloss, formation, strength attributes, and ash content are just a few of the quality criteria to consider. Quality characteristics such as basis weight, moisture, caliper, ash content, fiber orientation, brightness, and colour are monitored by a

paper machine function [5]. The conventional technique is to measure the MD and CD signals by scanning the sheet and the beta gauge develops corresponding analog outputs, which are given to Distributed Control System. A digital computer using these digital equivalents calculates a difference between the measured basis weight and the required basis weight and error signal is used to control the stock-flow rate by opening valves [6].

A paper machine role and operation is to create the paper sheet and remove the moisture from it and controls on paper machines attempt to maintain quality variables at their intended levels with the least amount of variation each paper is unique. There will be a grade, and it will have particular goals and objectives. Many quality criteria, such as Basis weight, have upper and lower limitations. Moisture, smoothness, formation, and strength properties are all factors to consider. Distribution of faults, caliper content, and ash content [5]. The techniques for evaluating Quality basis weight, moisture, caliper, and ash are some of the criteria to consider.

The composition, fiber orientation, brightness, of the product are all evaluated in a paper machine on-line and the system of quality control (QCS) is separated into two dimensions, one of which is one cross-machine direction control (MD), and the other was machine direction control (MD) control of the direction (CD). By scanning the sheet, you can determine the MD and CD signals [6]. This paper machine is divided into four divisions and defining segment transforms the pulp into the structure for the sheets that go along the wire. The excess water is removed by a sequence and generated by rolls pressing against each other, supported by press felts that hold the sheet and absorb the pressed water the dryer component of the paper machine, the name implies, dries the paper, Moisture is evaporated through a succession of internally steam-heated cylinders. Calendars are used to smoothness the paper's surface and make it bright Calendar rolls are often installed vertically in practice. The sensor is mounted on a scanning platform and travels in a cross-directional motion [6].

1.2 Paper Machine Process

The paper sheet comprises the following components throughout the manufacturing process:

Fiber, water, and filler are the three essential components. The paper sheet's fundamental weight is the total mass per unit of surface area. Identification of Plants before attempting to regulate and is the first step [8].

Paper from a paper machine that has a basis weight of the beta gauge was used to scan the paper. The beta gauge generates analog outputs that match the analog inputs. Distributed Control System is offered. The difference between these digital equivalents is calculated between the actual and planned base weight the foundational weight the valve error signal is sent out opening for controlling the rate of stock flow [9].

This paper presents a multi-objective optimization approach involving Genetic Algorithm, Particle Swarm Optimization, and Bacterial foraging Optimization, and firefly algorithm Optimization and in comparison with PSO and FFA algorithm is employed to the tuning of PID parameters K_p K_i K_d using the algorithm and simulation and The main purpose of this study is to create multi-objective optimization algorithms based on PID tuning approaches for improving the management of basis weight, moisture, and other variables. Initially, PID controller tuning with closed-loop Ziegler Nichol's method and PID parameters with ZN method assigned to tune automatically run input SISO process control system output as step response and to study the machine direction as an application to dc motor process plant for better response and performance.

II DESIGN OF PID CONTROL

The PID controller is constructed in such a way that it can maintain and vary the best response, then measure and derive transfer functions and operate closed-loop controllers. Then, the main goal of this study is to develop a multi-objective optimization algorithm real coded PSO PID control and FA PID controller of self-tuning and optimum for fitness function and multi-objective optimization methods involving Genetic Algorithm, Particle Swarm Optimization, and Bacterial foraging optimization and performances have been compared with the met. When the system is subjected to step and load fluctuations, these strategies can assist maximize design parameters including gain margin, phase margin, and closed-loop bandwidth [1].

The case study is based on the data collected from an ABB-DCS for Basis Weight, Moisture and consistency Control. The DCS is used to collect 1000 input, output, and measurement data samples from this process are used to identify the processing system transfer function and processes have been designed control system simulation using MATLAB [1].

Case Study: Transfer Functions collected to Identify Process

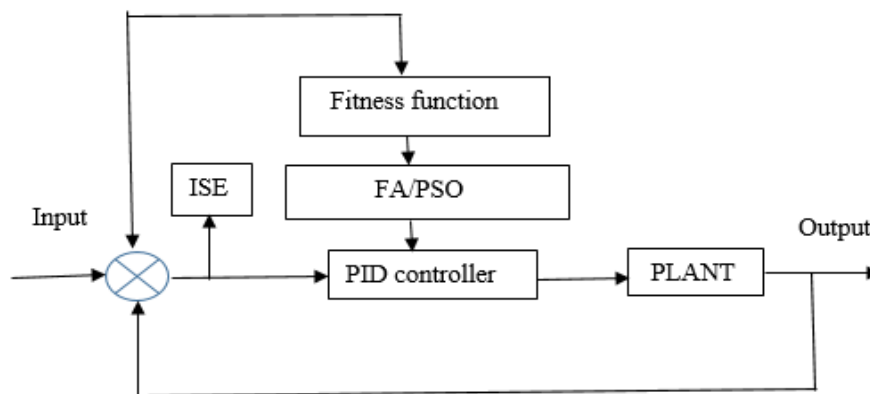

Figure 1: feedback control system

A PID controller in general form

$$u(t) = K_p e(t) + K_i \int_0^t e(t) dt + K_d \frac{de}{dt} \quad (2.1)$$

Where $u(t)$ is the controller output,

$e(t)$ is the error, and t is the sampling time.

K_p is the proportional gain.

K_i is the integral time.

K_d is the derivative time.

2.1 Particle Swarm Optimization (PSO) Algorithm:

Eberhart and Kennedy (1995) introduced the particle swarm optimization (PSO) method, which is a stochastic optimization technique based on the swarm. The PSO algorithm models the social behavior of animals such as insects, cattle, birds, and fish. These swarms follow a cooperative food-finding strategy, with each member of the swarm modifying the search pattern in response to its own and other members' learning experiences [12].

PSO is a type of evolutionary computing algorithm. Figure (2) depicts the PSO operation flow. The method is based on swarm studies, such as bird flocking and fish schooling. Instead of employing evolutionary operators like mutation and crossover to alter algorithms, the PSO method places a flock of particles into the D-dimensional Search space with randomly determined velocities and locations, knowing their optimal values, for a d-variable optimization problem. The main design of the PSO algorithm is closely related to two types of research: One is the evolutionary algorithm, which, like the evolutionary algorithm, employs a swarm mode to explore a vast region in the solution space of the optimized objective function at the same time. Artificial life, on the other hand, is the study of artificial systems having life-like qualities. Millonas presented five essential ideas in researching the behavior of social animals with artificial life theory for how to develop swarm artificial life systems with cooperative behavior via computer [13].

These five concepts encompass the primary features of artificial life systems and have served as guiding principles in the development of the swarm artificial life system. Particles in PSO may adjust their locations and velocities in response to changes in the environment, therefore meeting the requirements of proximity and quality. Furthermore, the swarm in PSO does not limit its mobility and instead seeks for the optimal solution in the given solution space particles in PSO can maintain constant mobility in the search space while changing their movement mode in response to environmental changes. As a result, particle swarm systems adhere to the five principles listed above. So far (p best), as well as the position in d-dimensional space. Each particle's velocity is changed based on its own flying experience as well as that of the other particles [13].

$$Vx[] = w.vx[] + c_1 * \text{rand}() * (\text{pbest}[] - \text{present}x[]) + c_2 * \text{rand}() * (\text{gbest} - x[]) \quad (2.1)$$

$$X_i = x_i[] + v_i[] \quad (2.2)$$

Equation (2.1) is used to calculate new velocity particle when the previous velocity and distances of current position from the know best position and Equation (2.2) is particle files toward a new position and the performance of particular particle is measures fitness function and capable of search between the global and position best and shows the results as PSO different performance.

Using the current velocity and distance from P best i,d to g best i,d, the adjusted velocity and location of each particle may be determined as given in the formulas below [12].

The controller was created with the goal of maintaining the highest possible output. The appropriate controller is then constructed after obtaining the transfer function model. This is accomplished by carefully choosing the tuning parameters K_p , K_i , and K_d for a PID Controller

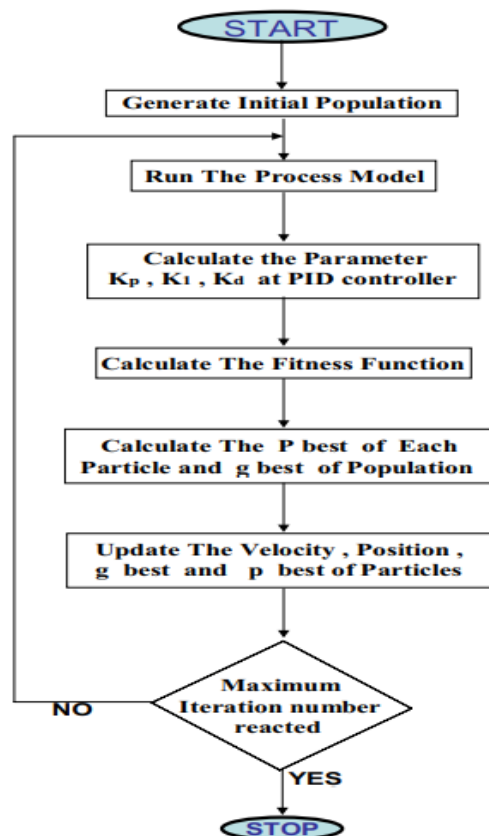

Figure 2 : Flowchart of PSO

2.2 Genetic Algorithm (GA)

Genetic Algorithm (GA) are a kind of optimization that mimics the natural evolution process. The mechanics of genetics and the process of selection created this. Artificial intelligence is a subset of evolutionary computing. The selection of appropriate goal functions is a crucial aspect of GA. We must determine the function best value [9].

Genetic algorithms search for the optimal solution from a set of possible solutions and begin searching randomly for the best one. The population is made up of these groups of solutions, and each chromosome is one of them. On the basis of their fitness value, these chromosomes are compared to one another. After that, the member who is the most physically fit is chosen. Mutation, crossover, and reproduction are three basic processes in the GA algorithm.

The GA self-tuning PID parameters are used to find K_p , K_i , and K_d . The fitness function, in this instance the error criteria, settling time, rising time, and peak overshoot, is minimized by varying the values of all feasible combinations of controller parameters. It verifies that the estimated controller settings result in a stable closed-loop system for the PID controller model. Writing the objective function is the most challenging element of designing a genetic algorithm. The target function in this project is to determine the optimal PID controller for the system. To discover a PID controller with the shortest overshoot, fastest rising time, or quickest settling time, a multi-objective function was designed [14].

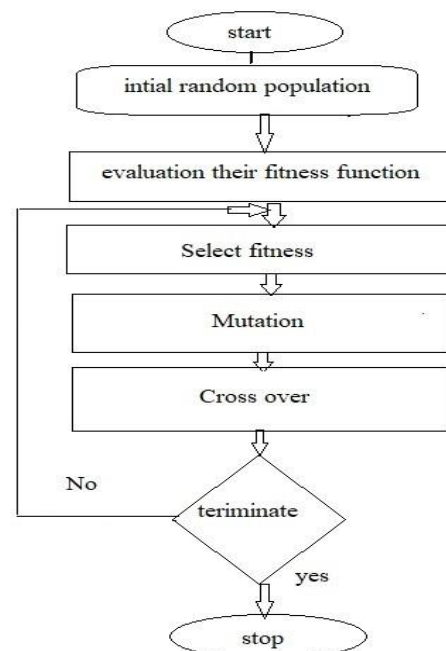

Figure 3: Flowchart of GA

2.3 Firefly Algorithm Optimization (FA)

In the optimization of the firefly algorithm is a metaheuristic algorithm proposed by xin-she yang and inspired by the flashing behavior of fireflies [2].

The fireflies are the flashing light nature is a wonderful sight in the summer sky in the tropical regions and temperate regions occur. Then, firefly species produce rhythmic flashes and are unique for the particular species and different types of species living in oceans produce unique rhythmic flashes with attracting with flashing light. Then there are about 2000 firefly species that are mostly rhythmic flashes and these are produced by the process of bioluminescence and are two fundamental functions of such flashes are to attract potential and also attend as a protective warning system mechanism.

The firefly attraction of rhythmic flash by the process exchange and attraction of part of a signal system that brings Females to respond to the male's distinctive flashing pattern in the same species, and both sexes work cooperatively.

The inverse square law governs the light intensity at a given distance r from the light source. In terms of $I \propto 1/r^2$, this means that as the distance r rises, the light intensity I decreases. Furthermore, as the distance grows, the air absorbs light, which gets dimmer and weaker. These two elements combine to make most fireflies visible only from a short distance at night, generally a few hundred meters [3].

In most circumstances, fireflies can communicate just by looking at each other. The flashing light is systematically developed and then the way is can be formulated in such a way that it is related with the objective function to be improved and best iteration value will be fitted and formulate the new optimization algorithm and the basic procedure followed according to the algorithm flowchart from the figure (3).

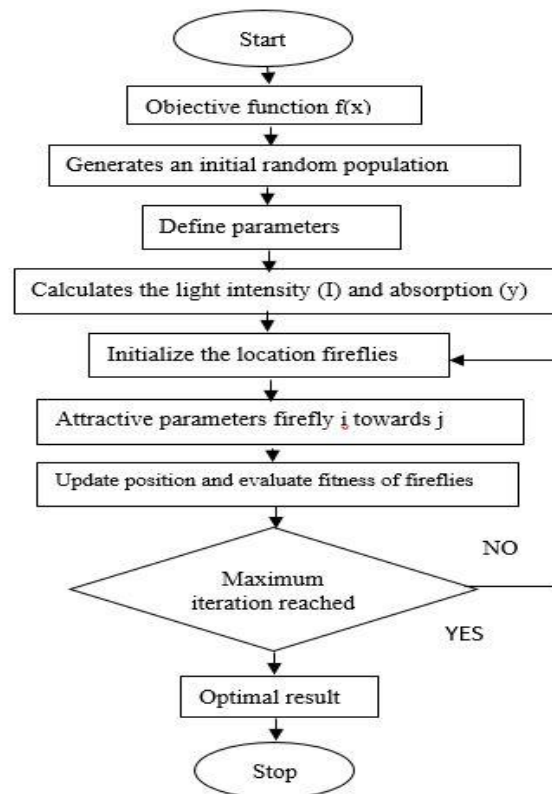

Figure 3: Flowchart of FA algorithm

Each firefly in this approach has a d -dimensional position $X=(x_1, x_2, x_3, \dots, x_d)^T$ and a light intensity $I(x)$ or attractiveness $\beta(x)$ that are proportional to the objective function $f(x)$. Attractiveness $\beta(x)$ and light intensity $I(x)$ are relative terms that should be evaluated by the other firefly. As a result, it will change depending on the r_{ij} distance between firefly i and firefly j . Hence, the attractiveness β of firefly can be defined by [4].

$$\beta = \beta_0 e^{-\gamma r^2} \quad (2.3)$$

where r is the distance between any two firefly i and j at x_i and x_j , respectively

Cartesian distance, β_0 is attractiveness at $r=0$ and is the light absorption coefficient in the environment. The initial solution is generated based on

$$X_j = \text{rand} (Ub-Lb)+Lb \quad (2.4)$$

Each firefly i can move toward another more attractive (brighter) firefly j by

$$X_i^{r+1} = X_i^r + \beta \exp[-\gamma r_{ij}^2] + \alpha_t(\text{rand}-1/2) \quad (2.5)$$

Where α_t is a substantial randomization parameter factor, and the random has a uniform distribution $U(0, 1)$ is a random number and a random generator derived from the uniform distribution.

The distance $r_{i,j}$ between any two fireflies is known as the Cartesian distance i and j at X_i and X_j , respectively

$$r_{i,j} = |X_i - X_j| = \sqrt{\sum_{k=1}^d (X_{i,k} - X_{j,k})^2} \quad (2.6)$$

Where $x_{i,k}$ is the k th spatial coordinate component X_i of the i th firefly.

2.4 FA-based PID controller tuning

In the optimization of the firefly algorithm, tuning of PID controller gains to make sure optimal control performance at nominal operating conditions. FA algorithm is working to tune PID parameters k_p k_i k_d using the algorithm and simulation. FA algorithm starts with objective function $f(x)$ and generates an initial random population and to define parameters and then calculates the light intensity (I) and absorption (γ) and

initialize the location fireflies and tuning of attractive parameters i towards j moves and calculates the new solutions and update light intensity. PID parameters (k_p k_i k_d) assign to the plant for tuning of input response as SISO Single –input single-output process control loop as plant model transfer functions will evaluate as step response will set output response. The efficiency of the plant has proved that comparing the control performance with optimizations methods and a good set of PID controller parameters as self-tuning PID with fast and better response by observing time domain specifications.

III SIMULATION RESULTS

3.1 Simulink model of FA-based PID controller tuning

In the conventionally ZN tuning PID controller, the plant response produces high overshoot and long settling time, for better performance and fast settling time and less overshoot with the implementation of FA-based PID controller tuning. The PSO self-tuned using PID controller system displays a better performance and the closed-loop step response for the different tuning methods.

From Table 1, the multi-objective PSO, In comparison to BFO ZN GA techniques, FA methods provide a system with no overshoot, a shorter settling time, and a faster rising time. The Z-N method's closed-loop response has a higher overshoot and a longer settling time. In comparison to other tuning approaches, the FA method provides control performance with enhanced dynamic performance criteria.

3.2 Simulink model for FA based tuning for PID controller

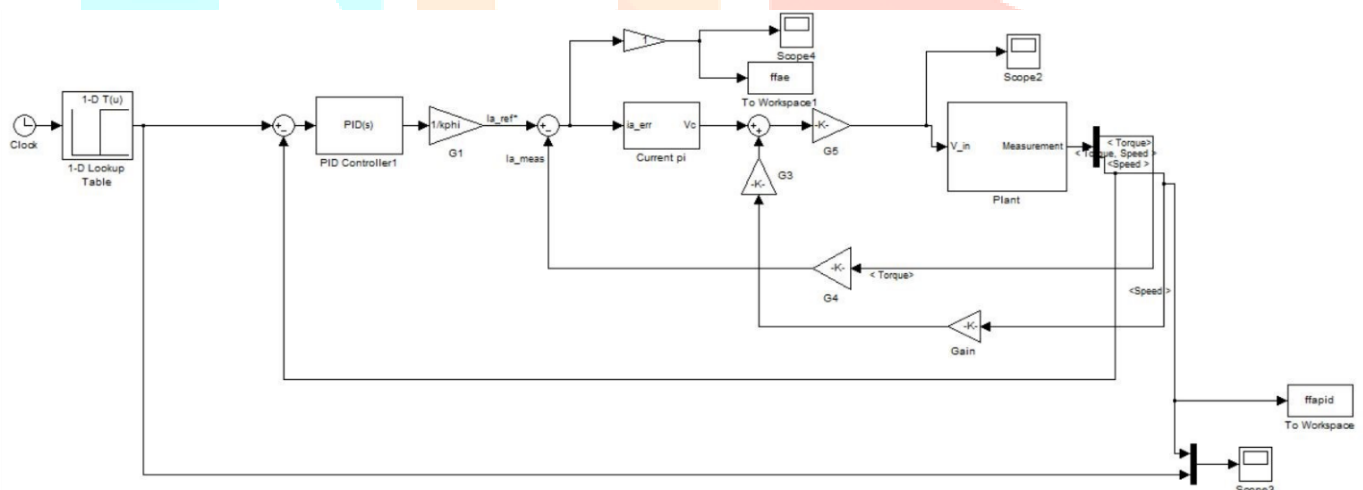

Figure 5: Simulink model of FA-based PID controller

3.3 Performance Comparison

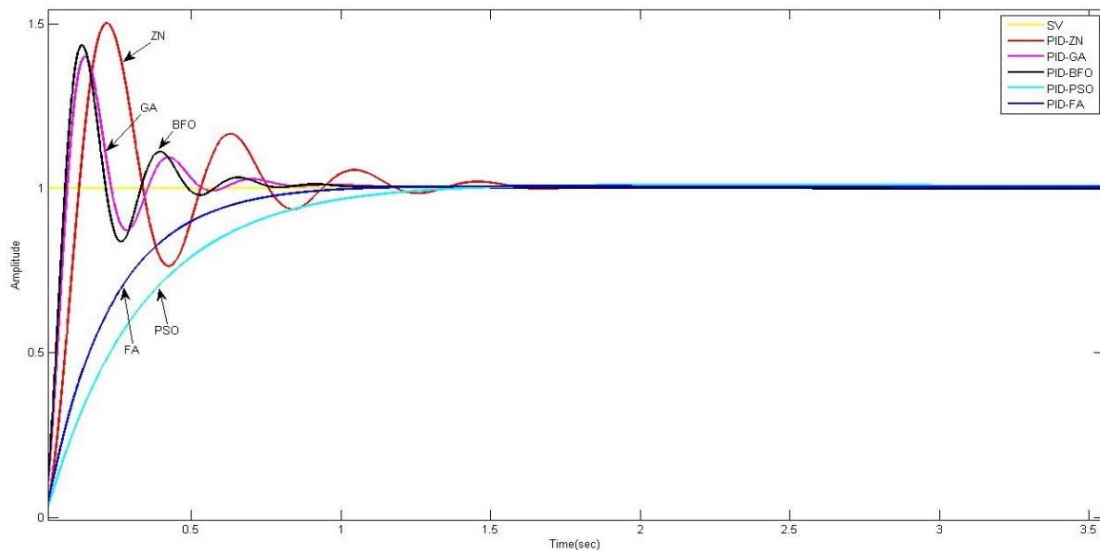

Figure 6: step response results from Comparison Methods

3.4 Simulation result integral error waveform

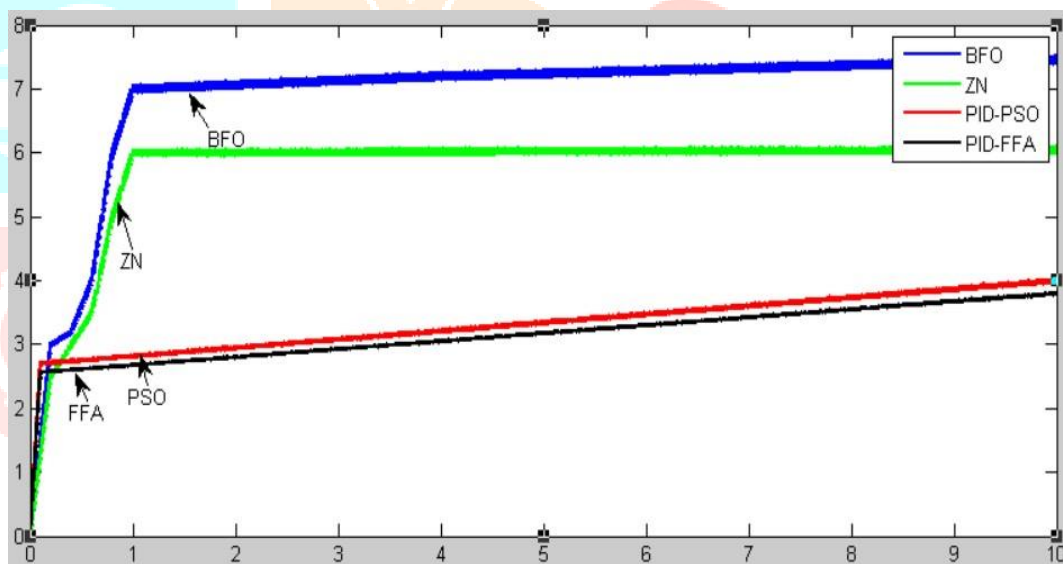

Figure 7: integral error waveform with Comparison Methods

Finally, PID controllers and many system models are available. The performance of the provided approach is superior to that of other strategies that may be compared utilizing various methods. With the use of MATLAB simulation, their responses to a unit step input are evaluated. A comparison of time-domain parameters and performance index for the derived models with the designed controllers is shown in a table. To determine the values of K_p , K_i , and K_d , traditional methods such as Ziegler Nichol's method are used.

The FA self-tuned using PID controller system displays a better performance and the closed-loop step response for the different tuning methods. As a result, multi-objective optimization techniques are added to the control loop. Tuning approaches based on FA, GA, PSO, and BFO have shown their effectiveness in enhancing steady-state features and performance indices. As demonstrated in the figures, performance features of the process were indicated and compared to intelligent tuning approaches and values were tabulated.

3.5 Simulation result of error waveform (Sampling instants)

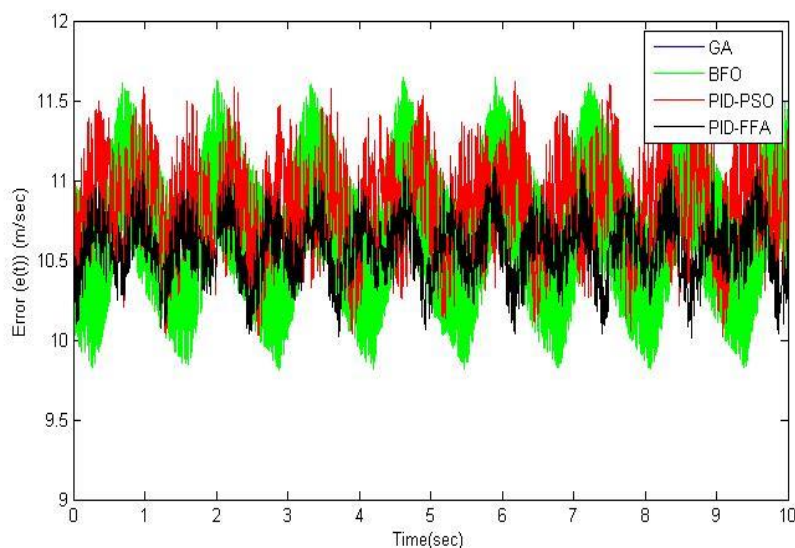

Figure 8: Error waveform with Comparison Methods

IV TABLE 1

Different Methods Comparison with PID Controller Parameters Time Specifications and Performance Index

Methods	KP	KI	Settling time (ts) (sec)	Rise time(tr) (sec)	overshoot Mp(%)	Integral square error(ISE))
PID ZN	5.4500	0.5200	1.79	0.030	78.2	2.3
PID GA	7.000	0.0169	0.617	0.039	46.1	1.65
PID PSO	4.8200	0.0089	0.35	0.26	0	0.2078
PID FA	4.5210	0.0075	0.32	0.23	0	0.147

V CONCLUSION

In this chapter concludes that the results, For a basis weight, moisture, and consistency, the research work was carried out to obtain an ideal PID tuning by employing multi-objective optimization based on GA, PSO, and BFO, FA control operations in the direction of the machine (MD). The soft computing-based controller's performance is compared to traditional PID controller tuning settings.

The values of Kp, Ki, and Kd are determined using the traditional Z-N approach traditional approaches are unable to deliver the optimal solution however, they do supply the beginning values or boundary values required to begin the soft computing processes. Following the derivation of the transfer function, the controller must be constructed to keep the system at its optimal set point. This may be performed by carefully selecting the Kp, Ki, and Kd tuning parameters for a PID Controller and decreasing the error (ISE).

The responses show that the FA-based multi-objective PID controller has a better closed-loop performance and the controller is able to function because of the loop time constant. With the correct balance of overshoot and settling time, its fast response and the designed PID controller using the FIREFLY algorithm show superior performance over the different multi-objective optimizations, System overshoot, settling time, and rising time are all factors to consider.

REFERENCES

- [1] Nisi, K., Nagaraj, B. & Agalya, A. “Tuning of a PID controller using evolutionary multi-objective optimization methodologies and application to the pulp and paper industry”. *Int. J. Mach. Learn. & Cyber.*
- [2] Yang, X. S. (2008). *Nature-Inspired Metaheuristic Algorithms*. [Luniver Press](#). ISBN 978-1-905986-10
- [3] Yang, X.-S. (2009) “Firefly Algorithms for Multimodal Optimization. In *Proceedings of the Stochastic Algorithms: Foundations and Applications*” 5th International Symposium, SAGA 2009, Sapporo, Japan, 26–28; pp. 169–178.
- [4] Johari, Nur & Zain, Azlan & Mustaffa, Noorfa & Udin, Amirmudin. (2013). Firefly Algorithm for Optimization Problem. *Applied Mechanics and Materials*.421. 10.4028
- [5] Kjaer A.P., Wellsted P.E. and He Kjaer A.P., Wellsted P.E. and Heath W.P. On-Line Sensing of Paper Machine Wet-End Properties: Dry-Line Detector. *IEEE Transactions on control systems Technology*, Pp 571–585 (1997).
- [6] Wang X. G., Dumont G.A. and Davies M.S. Adaptive Basis Weight Control in Paper Machines. *IEEE Conference on Control applications, Vancouver*, Pp 209-216 (1993).
- [7] T. K. Sethuramalingam (2014) “PID Controller Tuning using Soft Computing Methodologies for Industrial Process A Comparative Approach” *Indian Journal of Science and Technology*, ISSN: 0974-6846, Vol: 7, Issue: is7, Page: 140-145
- [8] Wikipedia contributors. (2021, December 3). “Paper machine”. In *Wikipedia, The Free Encyclopedia*.
- [9] Nagaraj B, Vijayakumar P (2011) “Tuning of a PID controller using soft computing methodologies applied to basis weight control in paper machine”. *J Korean Techn Assoc Pulp Paper Ind* 43(3):1–10
- [10] D. Kumanan & B. Nagaraj (2013) “Tuning of Proportional Integral derivative controller based on firefly algorithm, *Systems*” *Science & Control Engineering*, 1:1, 52-56
- [11] Wikipedia contributors. (2021, December 25). “PID controller”. In *Wikipedia, The Free Encyclopedia*.
- [12] Tae-Hyoung Kim, Ichiro Maruta and Toshiharu Sugia, (2007) “Particle Swarm Optimization based Robust PID Controller tuning”, *IEEE Conference on decision and control*, Pp 200–205.
- [13] Wang, D., Tan, D. & Liu, L. (2018) “Particle swarm optimization algorithm: an overview”. *Soft Comput* **22**, 387–408
- [14] B.Nagaraj, S.Subha, B.Rampriya (2008)“Tuning Algorithms for PID Controller Using Soft Computing Techniques” *IJCSNS International Journal of Computer Science and Network Security*, VOL.8 No.4, pp 278–281.
- [15] Nagaraj B, Vijayakumar P (2012) “Tuning of a PID controller using soft computing methodologies applied to moisture control in paper machine”. *Int J Intell Automat Soft Comput J* 18(4):399–411
- [16] Agalya A, Nagaraj B, Rajasekaran K (2013) “Concentration Control of continuous stirred tank reactor using particle Swarm Optimization algorithm.” *Trans Eng Sc* 1(4):57–63
- [17] Nagaraj B, Vijayakumar P (2012) “Evolutionary computation based controller tuning— a comparative approach”. *Int J Indian Pulp PapTech Assoc.* 24(2):85–90
- [18] Vidhya S, Nagaraj B (2012) “Fuzzy based PI controller for Basis weight process in paper industry”. *J Fuzzy Syst*
- [19] Nagaraj B, Muruganath R (2010) “Soft computing-based optimum design of PID controller for a position control of DC motor.” *Acta Electrotech Acad Tech Sci Romania* 51(1):21–24
- [20] Nagaraj B, Vijayakumar P (2012) “Bio inspired algorithm for PID controller tuning and application to the pulp and paper industry.” *Sens Trans J* 145(10):149–162 (ISSN 17265479)

[21] Sethuramalingam TK, Nagaraj B (2016) “A Proposed System of Ship Trajectory Control Using Particle Swarm Optimization” Elsevier Proc Comput Sci 87:294–299.

[22] Kumanan D, Nagaraj B (2013) “Tuning of proportional integral derivative controller based on firefly Algorithm” Syst Sci Control Eng J 1:52–58.

