



## PERFORMANCE ANALYSIS OF HIGH STEP – UP STACKABLE SWITCHING BOOST INVERTER WITH FUZZY LOGIC CONTROLLER

<sup>1</sup>Dr.K.Eswaramoorthy, <sup>2</sup>V Digna

<sup>1</sup>Associate Professor, Narsimha Reddy Engineering College, Secunderabad, Telangana, India.,

<sup>2</sup>PG Scholar, Narsimha Reddy Engineering College, Secunderabad, Telangana, India.

**Abstract:** Over the past decade, energy utilization from the power grid has increased rapidly due to the increasing demand from various users and the emergency of high-power industries and factories. This may led down to very high global emissions with different conventional energies generation. Therefore, the penetration of renewable energy sources into the power grid has increased rapidly and also for domestic applications AC (alternating current), so for that reason an inverter is needed, by taking this thing into consideration newly proposed a design and implementation of a high step-up stackable switching boost inverter for renewable energy sources for applications. Many boost converters, boost inverters and multilevel inverters are invented for boosting voltage levels but then to convert it into AC to use it in domestic applications, so for that reason an multilevel boost inverter for medium voltage and for high power applications are used and also for With controller to control the output. The high step – up stackable switching boost inverter without controller, with PI controller and with fuzzy logic controller. Compared their simulation results of each without controller and with controllers.

**Index Terms** - Fuzzy logic controller, Multileveboost inverter, step-up converter, PI controller, Total Harmonic Distortions.

### I. INTRODUCTION

These days, with the lack of non-renewable power assets and eco- friendly problems inside the traditional force era, researchers are paying hobby toward renewable energy assets. New inventions and new technology from renewable energy assets are gambling a essential role in strength era through nearly 20 to 30% in a year. Due to high performances and excessive-voltage benefit from dc-dc converters had been used widely in strength conversion level in dc system. Excessive step dc-dc converters are required in many applications, along with electric powered cars, gas mobile powered systems, telecommunications power gadget, DC back-up energy gadget for a UPS. Theoretically, the traditional improve dc-dc converter can be an ok solution for many packages. A DC-to-DC converter is a digital circuit or an electromechanical device that converts a source of direct contemporary (DC) from one voltage degree to any other. DC-DC converters are excessive - frequency electricity conversion circuits that use high - frequency switching and inductors, transformers, and capacitors for smoothing out switching noise into regulated DC voltage. The result in the additional power converter with - level dc-dc-ac power conversion is high value and low efficiency. For normal issues what we had taken into consideration DC-DC improve Converter issues, internally some electronics gadgets need a DC electricity, DC-AC multilevel inverter troubles over coming. So due to this motives we select DC-AC increase inverter.

In this paper we that specialize in offering a new answer for growing a new electricity inverter topology. Specifically for the needs of excessive voltage profits, low value implementations and high performance. mainly, we suggest a excessive step-up DC-AC Inverter without controller , with PI controller and with fuzzy logic controller. the operation standards, simulation outcomes and comparisons of every simulation model without controller, with PI controller and with fuzzy logic controller are defined actually.

### II. BASIC BOOST DC-DC CONVERTER

A boost converter (step-up converter) is a DC-to-DC power converter which steps up voltage while stepping down current from its input (supply) to its output (load). The capability of storing electricity in inductor is carried out by using dc-dc increase converter, which electricity is provided to load with better voltage.

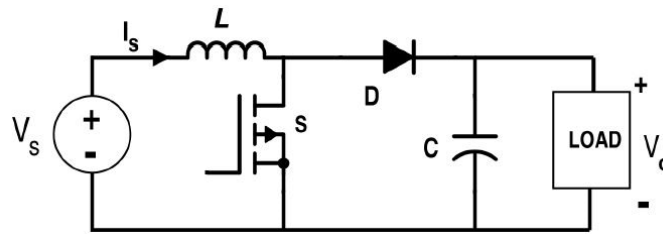


Fig.1 Circuit diagram of a Basic DC-DC Boost Converter

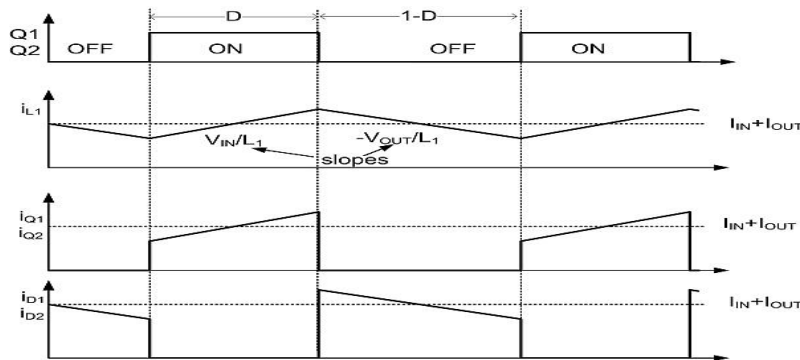


Fig. 2 waveforms of a Basic Dc-Dc Boost Converter

The fig 1 illustrates a step-up or a boost converter. It includes DC enter voltage supply Vs, clear out capacitor C, improve supply inductor L, controlled switch S, diode D, and cargo resistance R. while the switch S is within the on function, the present day inside the increase inductor will increase immediately and the diode D is off at that time instant. while the transfer S is grew to become off and the electricity stored in the inductor is free through the diode to the output RC circuit.

Using Faraday’s law for the boost inductor

$$V_s DT = (V_o - V_s) (1-D) T \tag{1}$$

VSdT from which the dc voltage transfer function seems to

$$M_v = \frac{V_o}{V_s} = \frac{1}{1-D} \tag{2}$$

Because of the call of the converter indicates, the output (load) voltage is constantly more than the input(enter) voltage.

Then this boost converter perform within the CCM for  $L > L_b$  in which

$$L_b = \frac{(1-D^2)DR}{2f} \tag{3}$$

As shown in the fig 2 the current is provided to the output (load) RC circuit is discontinuous. a larger capacitor filter out is needed in evaluation with the buck-derived converters to reduce the output voltage ripple. The capacitor clear out must offer the dc output modern-day-day to the burden while the diode D is off. The minimal fee of the capacitor filter out that effect in the voltage ripple Vr is given via

$$C_{min} = \frac{Dv_o}{V_r R f} \tag{4}$$

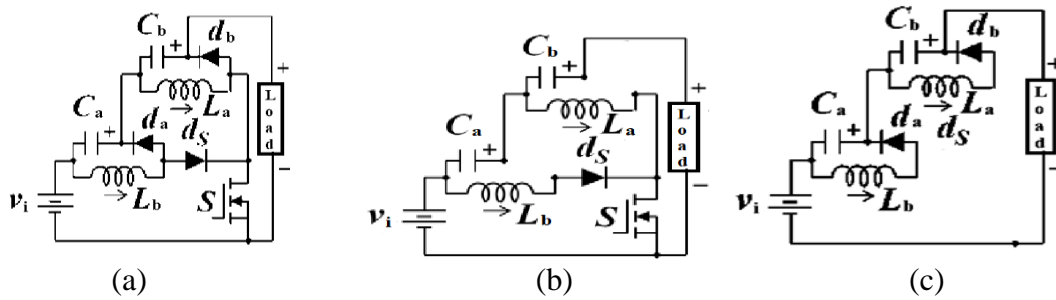
and, the minimal capacitance for the increase converter is Cmin.

### III. PROPOSED BOOST INVERTER

Renewable energy resources consisting of solar energy, wind electricity, tidal power, and hydro power generate low stage DC input voltage, to growth the voltage we require a DC–AC boost inverter related to the AC grid. There are wide variety of inverter preparations are suitable for PV self-sustained and grid-connected system. The DC-AC increase inverters have been given most popularity within the current instances with the aid of the primary researches, see. These fashions now not simplest perform DC-AC conversion but they also step-up the voltage being therefore brilliant opportunity for solar micro inverter applications. The fee of single-stage inverter topologies is also less, and their size is decreased because of the use of small reactive components. Furthermore, their efficiency is higher. The 1-phase, single-level boost inverter is changed into first mentioned in and proposed a easy DC–AC improve inverter that requires best 4 switches. The boost inverter topology is able to generating a sinusoidal voltage in a single stage with either big or a smaller amplitude in assessment to the input dc voltage. The traditional voltage source inverters (VSIs) are a buck dc–ac energy conversion, in which the dc supply voltage is higher than the height ac output voltage. in addition, both electricity switches in a leg can't be grew to become ON at the equal time because it reasons a quick circuit dc voltage supply . therefore, a further growth dc–dc converter is inserted in front of the inverter bridge to acquire ac output voltage even as also input voltage is much less.

### 3.1 Mathematical model for proposed SSBI

On this section, the stackable switching increase Inverter (SSBI) is proposed and also provide an explanation for its universal concepts of operation and running. The proposed converter is defined in detail, and contains a single energetic switch (S), capacitors (Ca, Cb), inductors (Lb) and 3 diodes (da, db, ds).



**Fig. 3** Proposed converter (a) Proposed Quadratic dc-dc boost Converter, and its equivalent Circuits, (b) when the switch (S) is Closed and (c) when the transfer(S) is Open.

They are two equivalent circuits in the desired converter that result in the switching. in the following assessment, don't forget standard assumption in energy electronics which includes the small-ripple approximation for the voltage at some point of capacitors and non-forestall conduction mode for currents through \$I\_a\$ and \$I\_b\$. while switch \$S\$ is closed (Fig.3.(b)), while diode \$d\_a\$ is reversed biased and therefore blocks the voltage \$v\_{ca} + v\_i\$, the current via \$L\_b\$ is similar to that of diode \$d\_s\$. similarly, the diode \$d\_b\$ is reversed biased and blocks the voltage \$v\_{ca} + v\_{cb} + v\_i\$, at the same time as \$S\$ and \$d\_s\$ are accomplishing, the modern-day via \$L\_b\$ and \$L\_a\$ rise with a slope of \$v\_i/L\_b\$ and \$(v\_i + v\_{Ca})/L\_a\$ respectively. while the transfer is closed then the switching state may be described with the resource of the following differential version:

Switch is closed:

$$\begin{aligned}
 L_b \frac{di_{Lb}}{dt} &= V_g \\
 C_a \frac{dv_{ca}}{dt} &= -i_{Lb} - \frac{v}{R} \\
 L_a \frac{di_{La}}{dt} &= V_g + v_{ca} \\
 C_b \frac{dv_{Cb}}{dt} &= -\frac{v}{R}
 \end{aligned} \tag{5}$$

while transfer \$S\$ is open (Fig.3 (c)), which induces the diode \$d\_a\$ to be closed and capacitor \$C\_a\$ to be charged and inductor \$L\_b\$ is discharged with a slope equal to \$v\_{Ca}/L\_b\$. Analogously, inductor \$L\_a\$ is discharged with a slope identical to \$v\_{cb}/L\_a\$, which induces the diode \$d\_b\$ to be closed after which capacitor \$C\_a\$ is charged. In this case, the diode \$d\_s\$ reversely biased, blockading the voltage throughout \$C\_b\$. When transfer is open then the switching country may be explained through the subsequent differential version:

Switch is open:

$$\begin{aligned}
 L_b \frac{di_{Lb}}{dt} &= -v_{Ca} \\
 C_a \frac{dv_{Ca}}{dt} &= i_{Lb} - \frac{v}{R} \\
 L_a \frac{di_{La}}{dt} &= -v_{Cb} \\
 C_b \frac{dv_{Cb}}{dt} &= i_{La} - \frac{v}{R}
 \end{aligned} \tag{6}$$

In each cases the output voltage is define as \$v = V\_i + v\_{Ca} + v\_{Cb}\$, i.e. the sum of the enter voltage and the voltage across \$C\_a\$ and \$C\_b\$. The circuit diagram operation is showed in decide, wherein we display all analytical waveforms for currents via inductors \$L\_b\$ and \$L\_a\$, and additionally for voltages across capacitors \$C\_a\$ and \$C\_b\$ with appreciate to a switching order. Observe in line with parent, each inductors are charged concurrently while the transfer is closed (on), however with one-of-a-type rankings. As a substitute, whilst the transfer is open (off) the inductor \$L\_b\$ is discharged thru \$C\_a\$ at the same time as \$L\_b\$ is discharged via \$C\_b\$. In parent we are able to be conscious the charging/discharging slopes of every electricity storing element that allows obtaining an accurate interpretation of the voltage/contemporary ripples. Considering the voltage at some point of capacitors and cutting - edge via inductors as variables of interest. The common model, i.e. received by using way of state a averaging the above equations (5)-(6)is the following.

Average model:

$$\begin{aligned}
 L_b \frac{dI_{Lb}}{dt} &= DV_i - (1-D)VC_a \\
 C_a \frac{dV_{Ca}}{dt} &= -D I_{La} + (1-D)I_{Lb} - \frac{V}{R} \\
 L_a \frac{dI_{La}}{dt} &= D (V_i + VC_a) - (1-D) VC_b \\
 C_b \frac{dV_{Cb}}{dt} &= (1-D) I_{La} - \frac{V}{R}
 \end{aligned} \tag{7}$$

In which as \$D\$ denotes obligation cycle and uppercase variables denotes common values over a time period. The set of eqn. (7) constitute a nonlinear dynamic version of massive sign, because it describes the dynamics of the converter over an extensive range of operation.

IV. CONTROLLERS

The methodology section outline the plan and method that how the study is conducted. This includes Universe of the study, sample of the study, Data and Sources of Data, study’s variables and analytical framework. The details are as follows;

4.1 Effect of PI controller

When a PI Controller is added with a dc-dc boost converter to control a feedback control loop then that control loop calculates an error signal by taking into consideration only between the output of the system and set point. Closed loop control scheme is essential in power converters to meet the wanted load requirement. PI controller is one of the present control schemes. The use of PI controller increases system dynamic response and decreases unwanted peak overshoot compared to conventional PI controllers.

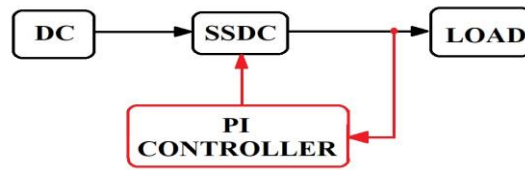


Fig.4 Block Diagram SSDC with PI Controller

4.2 Effect of fuzzy logic controller

A fuzzy logic controller is a control system completely based upon fuzzy logic, with a mathematical equations that analyse analog enter values in terms of good judgment variables so that it will take continuous values among zero and 1(one), quiet opposite to classical or digital logic controllers, which operates best in discrete values of both 1(one) or zero (proper or false).

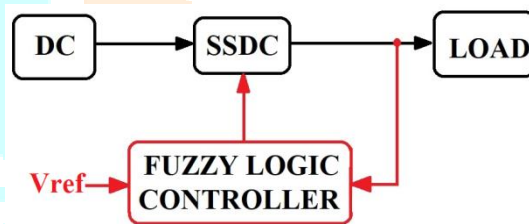


Fig.5 Block diagram of dc-dc converter with fuzzy logic controller

DC-DC converter with fuzzy logic controller is proven above to overcome many complexity troubles while using different form of controllers. The use of fuzzy logic controller in dc-dc converters is for better performances.

A fuzzy common sense controller may be carried out to the gadget by way of growing fuzzy logic control set of rules. The fuzzy good judgment controller is designed and calculated to make sure that everyone the additives specifically for inductor ought to be operated in continuous conduction mode.

Fuzzy logic controller is a quick-controlling controller evaluate to other conventional controller they degree exact mathematical details at all the time, due to that competition burden on they have become slow. With regards to fuzzy good judgment controller and received have any opposition burden, so they are rapid.

To obtain the reference output what we favored, then we should recognize the relation between the control sign and output of the device (or mistakes) must be recognized. The control sign of the device may be extended (or) decreased, the mistake (or) the desired output increases (or) decrease. Then we are able to design a fuzzy logic controller.

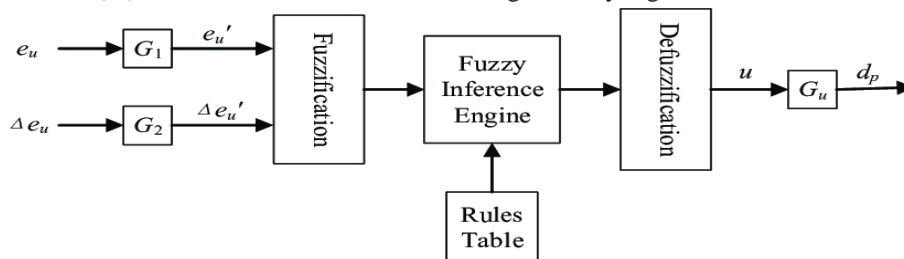


Fig.6 Fuzzy Inference System

In which the fuzzy logic output or controller it’s far converted once more into mathematical or genuine value which is then provided to the controller.

The designed clean Block diagram for electricity element Correction growth converter single phase rectifier the usage of Fuzzy common sense controller is established in parent. The operation of this circuit consists of a single phase rectifier; enhance converter, PWM (pulse width modulation) and Fuzzy appropriate judgment controller. The deliver of the circuit from DC enter from single phase rectifier. The output from increase converter is controlled with the beneficial resource of Fuzzy common sense manage technique within the remarks route. And linear programming rule on PWM ramp voltage to control duty cycle of the switch for shaping the enter current waveform.

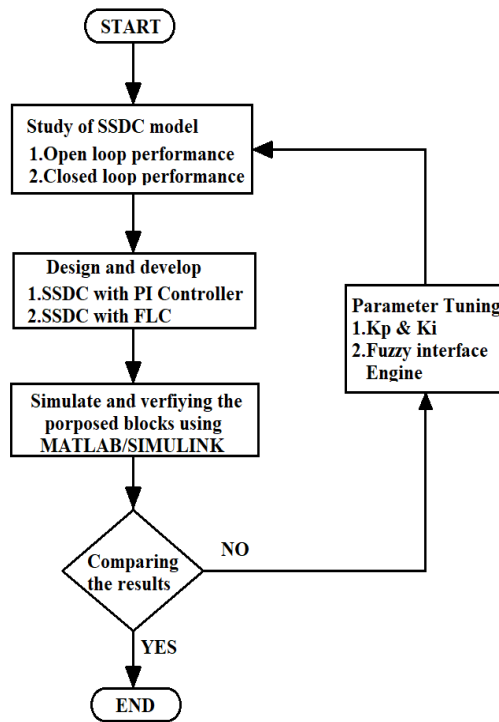


Fig.7. Methodology flowchart

An evaluation of a boost converter circuit discovered that an inductor cutting-edge plays important challenge in a dynamic reaction of a proposed converter. Furthermore, it is able to offer the storage electricity records inside the converter. As a result, any adjustments of inductor can also have an impact on output voltage and output voltage will offer constant state scenario. The 3 foremost parameters need to be considered. When designing decorate converters are energy switch, inductor, and capacitor. On this reason to advantage the favored output voltage.

Determine suggests Block diagram of Fuzzy logic (common sense) Controller for increase Dc to Dc Converter. Fuzzy logic (common sense) controller is based mostly on a Mamddani Fuzzy good judgment machine which contain inputs which might be described with the aid of equation , equation and simplest output variable.

$$e = V_{ref} - V_o \tag{13}$$

$$de / dt = e(k) - e (k-1) \tag{14}$$

$$\Delta U = k_1 e + k_2 de/dt \tag{15}$$

The bushy common sense controller, manipulate the output voltage (Vo). Fuzzy common sense controller has enter, mistakes voltage (e) and trade of blunders voltage (de). The mistake voltage is advantage from distinction amongst output feedback voltage (Vo) and reference voltage (Vref). The alternate in voltage (de/dt) is the distinction among errors voltage and former voltage.

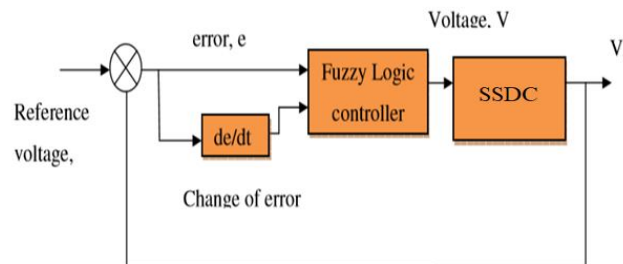


Fig. 8 A Block diagram Of a Fuzzy Logic Controller for a Boost DC to DC Converter

4.2.1 Membership function

The input (i/p) error voltage (e) and converting error voltage(de) have a seven state Function. Fuzzy logic controller look at two voltage membership feature and produced one output voltage club feature represents at FIS Editor as proven in determine. Some other figure indicates the enter mistakes voltage (e) within the fuzzy system have seven Membership feature. Parent constitute the enter variable (de) within the fuzzy system. Have seven membership functions. The output variable has seven states as shown in fig 10 -13.



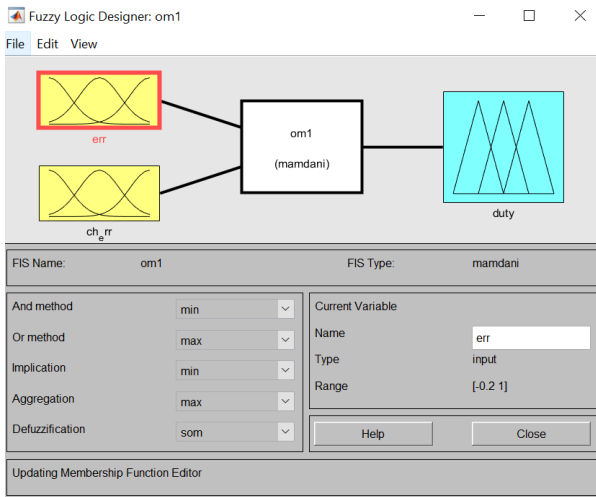


Fig.9 Fuzzy Logic Designer

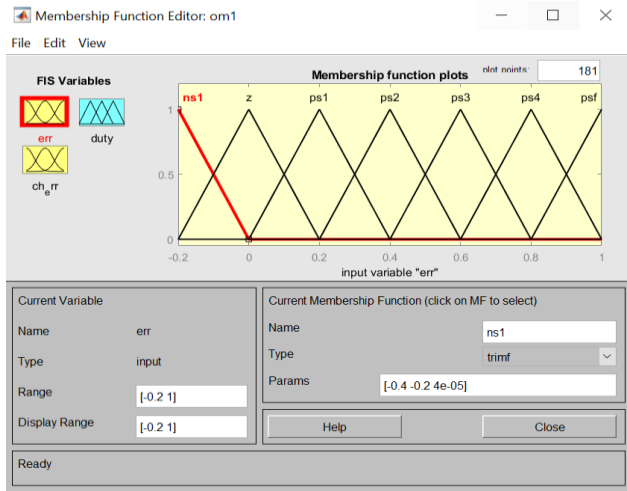


Fig.10 FIS Editor(Membership Function of input error(e))

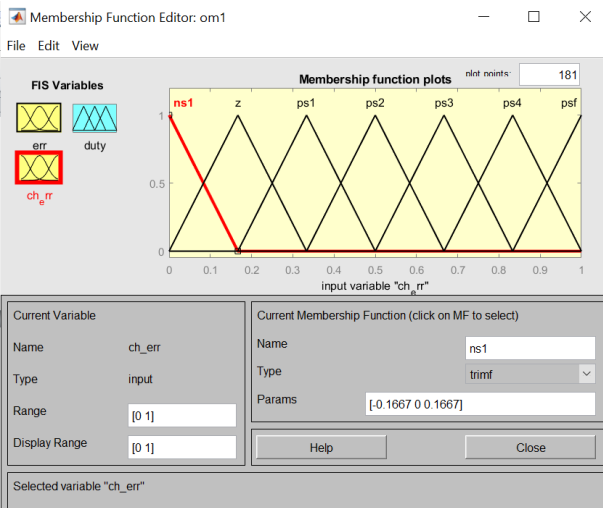


Fig.11 Membership Function of Change of error

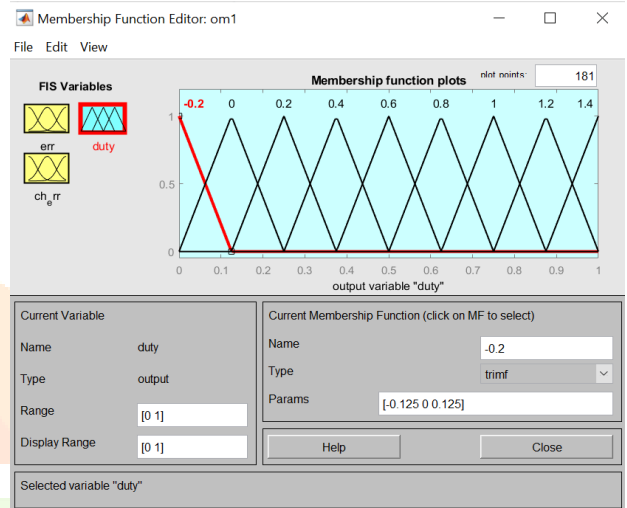


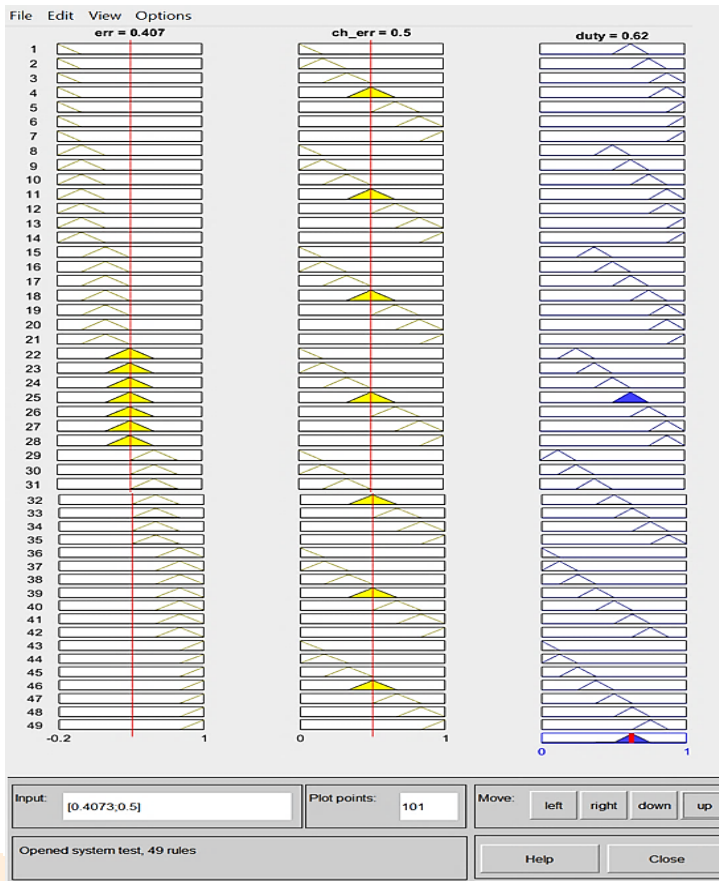
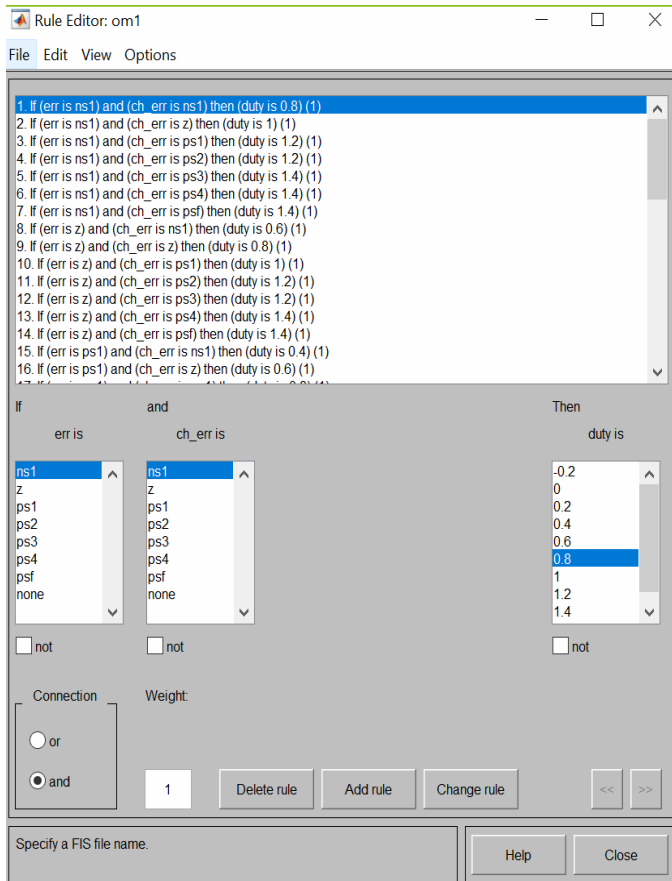
Fig.12 Membership Function of Output Variable (Duty)

4.2.2 Fuzzy Rules

Through the understanding and operating of the gadget the guideline are made the guideline of thumb base adjust the responsibility cycle for a PWM(pulse width modulation) of the boost converter based totally definitely upon the modifications inside the enter of fuzzy logic(common sense) controller. The wide variety of fuzzy pointers can be set as preferred. The hints primarily based totally encompass 25 policies, which is probably primarily based totally upon the five club abilities of the input variable. table three.0 indicates the bushy recommendations.

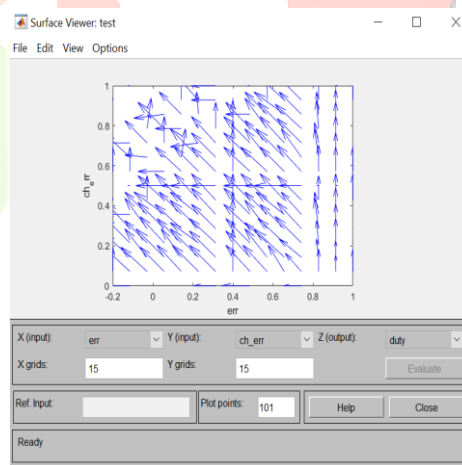
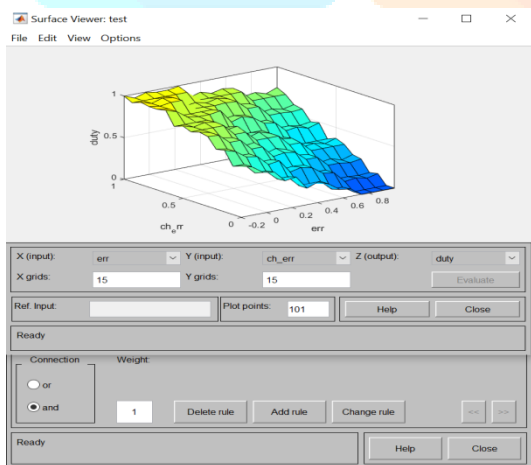
Through the two inputs is blunders & variable of mistakes and seven membership characteristic .forms the 25 pointers fuzzy policies are made. As an instance.

1. The trade of a duty cycle ought to be a large to supply the output to the reference factor, while the output (o/p) of the converter is a protracted manner from the reference aspect,.
2. A small change of responsibility in cycle is needed, while the output of the converter is drawing close to the reference point issue.
3. The responsibility cycle want to be stored regular as a manner to prevent Overshoot, at the same time as the output (o/p) of the converter is close to the reference factor and is drawing near it hastily.
4. The responsibility cycle ought to can be changed a touch bit to prevent the output from shifting away, while the reference element is reached and the output continues to be converting.
5. The obligation cycle is unchanged, while the set element is reached and output is steady.



**Fig.13** Rule Base or guidance For Proposed Fuzzy Logic Controller rules or guidance for this system design are as follows

**Fig.14** Rule View for Proposed Fuzzy Logic Controller

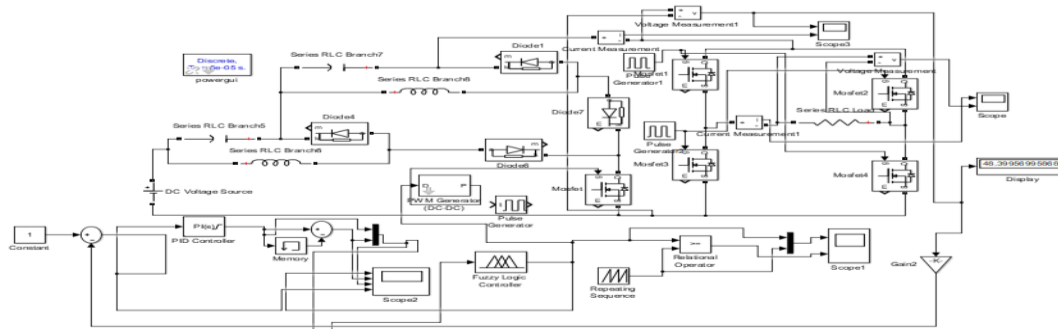


(a)

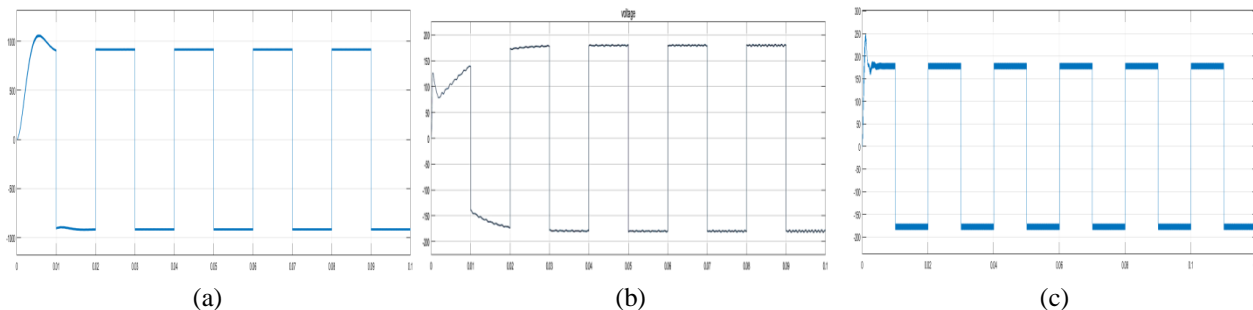
(b)

**Fig.15** FLC (a).surface view (b).flow surface view

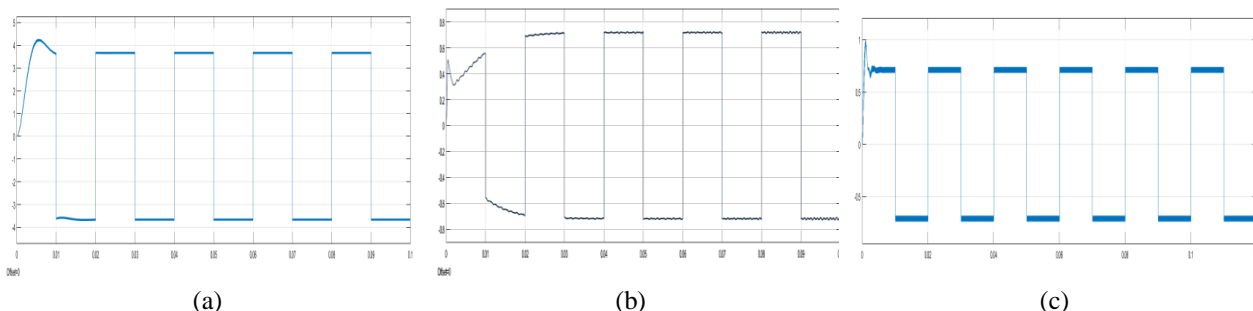
**IV. RESULTS AND DISCUSSION**



**Fig.16** Stackable Switching Boost Inverter with fuzzy logic Controller

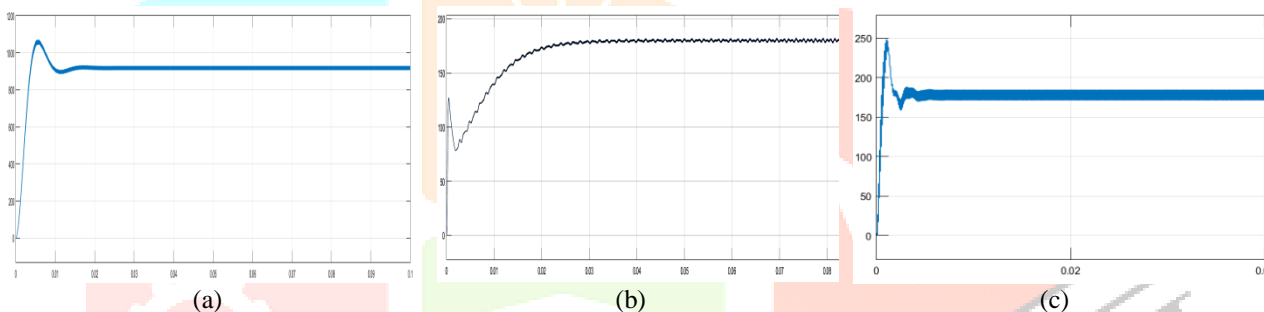


**Fig.17** SSBI Load voltage a).without controller b).PI controller and c). FLC

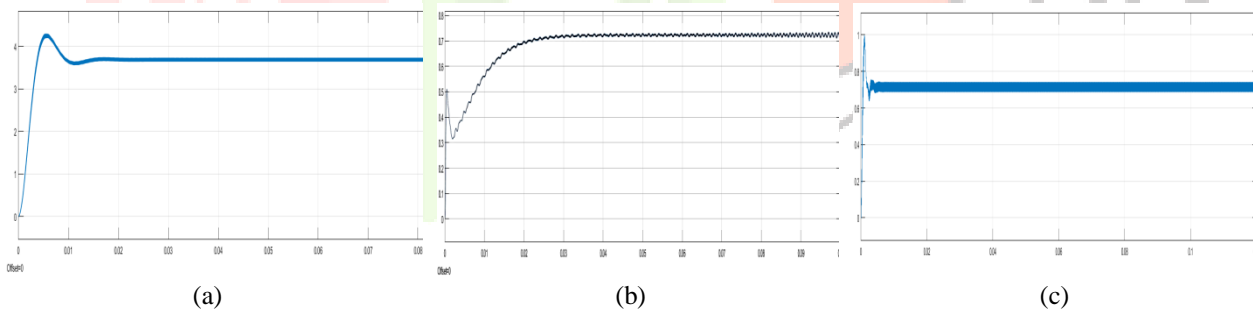


**Fig.18.** SSBI Load current a).without controller b).PI controller and c). FLC

SSBI load voltage value for without controller is 1200 volts, with PI controller is 180.2 volts and with FLC is 187.4 volts. SSBI load current value for without controller is 4.2 amps, with PI controller is 7.3 amps and for with FLC is 7.6 amps.



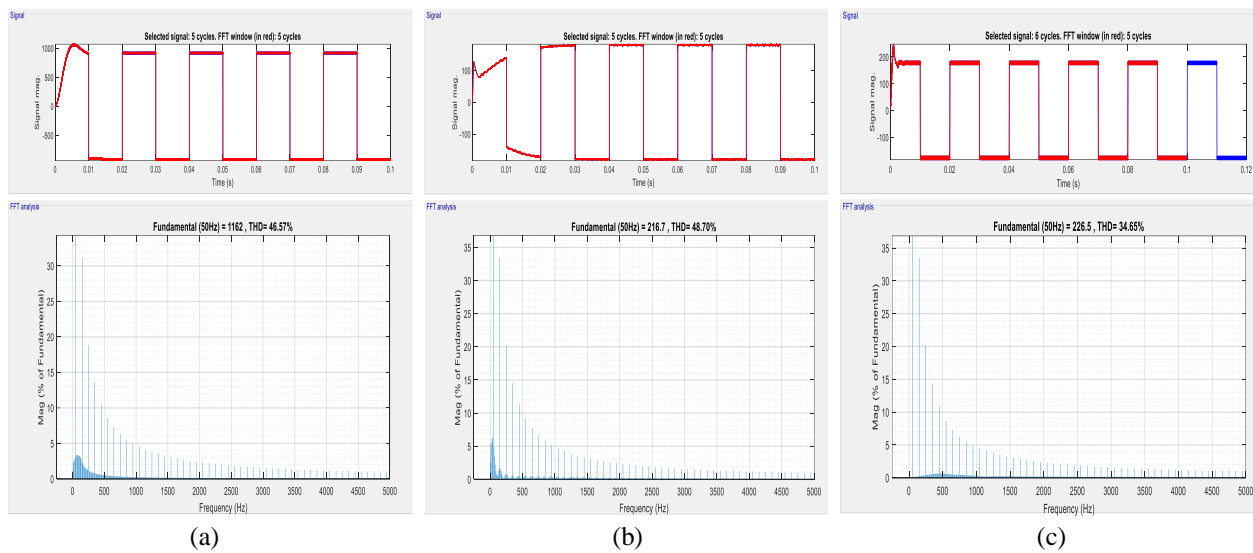
**Fig.19** SSBC voltage a).without controller b).PI controller and c). FLC



**Fig.20** SSBC current a).without controller b).PI controller and c). FLC

SSBC voltage value for without controller is 900 volts, with PI controller is 179.6 volts and with FLC is 184.6 volts. SSBC current for without controller is 3.7 amps , with PI controller is 7.2 amps and with FLC IS 7.5amps.





**Fig.21** SSBI THD spectrum a).without controller b).PI controller and c). FLC

SSBI THD spectrum percentage of without controller is 46.87 % , with PI controller is 48.70 % and with FLC is 34.69 %.

Table. 1. SSBI performance comparison with and without controllers

SSBI with controller	Voltage, volts	Current, Amps	THD
Without controllers	900 volts	3.7 amps	46.57%
PI controller	179.6 volts	7.2 amps	48.70%
FLC	184.6 volts	7.5 amps	34.69%

In the above given tabulation, all the results are compared. voltage of SSBI without controller is 900 volts, with PI controller is 179.6 volts and with FLC is 184.6 volts. now comparison of current without controller is 3.7 amps, with PI controller is 7.2 amps and with FLC is 7.5 amps and comparison of THD without controller is 46.57%,with PI controller is 48.70% and with FLC is 34.69%. after comparing , FLC is giving a better performances.

## V. CONCLUSION

In this report, a high boost or step-up stackable switching improve inverter with renewable electricity resources and packages become provided. Simple shape and easy manipulate due to using low quantity of power semiconductor switches are the primary capabilities of the proposed raise inverter. excessive step – up or boost dc – dc raise converter within the proposed inverter provides the prospect of intensifying the low output voltage by the PV module (or) dc voltage to reach the excessive top voltage to the machine. the designated mat lab simulink simulation confirmed the potential of the proposed inverter under high voltage situations and excessive performances of the proposed machine. Proposed without controller gives excessive voltage and contemporary output and THD percentage, proposed PI controller reduces the delay within the gadget and speedy manipulate operation and additionally preserve the regular voltage on the output load factor and proposed fuzzy logic controller, will increase the rate of the output and also reduces the complexity of the gadget within the operation. The simulation outcomes of model without controller, with PI controller and with fuzzy common sense controller are shown and as compared. Primarily based on our evaluation the proposed model for simulation without controller, PI controller and fuzzy logic controller, the FLC offers the quality effects over the others.

## REFERENCES

- [1] Proceedings of the 10th International Conference on Digital Strategies for Organizational Success (ICDSOS2019), Gwalior, India, 7 February 2019; pp. 1150–1159.
- [2] Curto, D.; Trapanese, M. A renewable energy mix to supply the Balearic Islands: Sea Wave, Wind, and Solar. In Proceedings of the 2018 IEEE International Conference on Environment and Electrical Engineering and 2018 IEEE Industrial and Commercial Power Systems Europe (EEEIC/I&CPS Europe), Palermo, Italy, 12–15 June 2018.
- [3] Eswaramoorthy, K., and V. K. Shunmughanaathan. "A Simple And Geometry Based Fast Space-Vector Pwm Technique For 15 Level Cascaded Multilevel Inverter With Reduction Of Switches." Asian Journal of Research in Social Sciences and Humanities 6, no. 10 (2016): 2305-2320.
- [4] Baydyk, T.; Kussul, E.; Wunsch, D.C., II. Renewable Energy: Solar, Wind, and Others. In Intelligent Automation in Renewable Energy; Springer: Cham, Switzerland, 2019; pp. 1–11.
- [5] Hodge, B.M.; Martinez-Anido, C.B.; Wang, Q.; Chartan, E.; Florita, A.; Kiviluoma, J. The combined value of wind and solar power forecasting improvements and electricity storage. Appl. Energy 2018, 214, 1–15. [CrossRef]
- [6] ESWARAMOORTHY, K., AND VK SHUNMUGHANAATHAN. "CONTROL OF THREE PHASE FOUR WIRE ASYMMETRICAL FIFTEEN LEVEL INVERTER USING HYBRID BI-TRI DIMENSIONAL SPACE VECTOR PULSE WIDTH MODULATION." Journal of Electrical Engineering 18, no. 4 (2018): 7-7.
- [7] Kabir, E.; Kumar, P.; Kumar, S.; Adelodun, A.A.; Kim, K.H. Solar energy: Potential and future prospects. Renew. Sustain. Energy Rev. 2018, 82, 894–900. [CrossRef]
- [8] Anand, R., A. Anbarasan, K. Eswaramoorthy, and P. Muthukumar. "HPSOMPC Control of Bidirectional Series Resonant DC/DC Converter." (2020).
- [9] REC - Profile & Reviews. Available online: <https://www.energysage.com/supplier/20083/rec/> (accessed on 9 August 2017).

- [10] Muthukumar, P., Venkata Ramesh Maddukuri, K. Eswaramoorthy, N. Veeramuthulingam, and T. Jarin. "The review and investigation of sustainable 13-level multilevel inverter control strategies." *World Review of Science, Technology and Sustainable Development* 17, no. 2-3 (2021): 153-171.
- [11] Yahya-Khotbehsara, A.; Shahhoseini, A. A fast modeling of the double-diode model for PV modules using a combined analytical and numerical approach. *Sol. Energy* 2018, 162, 403–409. [CrossRef]
- [12] Han, J.; Lu, L.; Yang, H.; Cheng, Y. Thermal regulation of PV façade integrated with thin-film solar cells through a naturally ventilated open air channel. *Energy Procedia* 2019, 158, 1208–1214. [CrossRef]
- [13] Ahmad, T.; Sobhan, S.; Nayan, M.F. Comparative analysis between single diode and double diode model of PV cell: Concentrate different parameters effect on its efficiency. *J. Power Energy Eng.* 2016, 4, 31. [CrossRef]
- [14] Basha, C.H.; Rani, C.; Brisilla, R.M.; Odofin, S. Mathematical Design and Analysis of Photovoltaic Cell Using MATLAB/Simulink. In *Soft Computing for Problem Solving*; Springer: Singapore, 2020; pp. 711–726.
- [15] Islam, M.T.; Huda, N.; Abdullah, A.B.; Saidur, R. A comprehensive review of state-of-the-art concentrating solar power (CSP) technologies: Current status and research trends. *Renew. Sustain. Energy Rev.* 2018, 91,987–1018. [CrossRef]
- [16] Linares-Flores, J.; Guerrero-Castellanos, J.F.; Lescas-Hernández, R.; Hernández-Méndez, A.;Vázquez-Perales, R. Angular speed control of an induction motor via a solar powered boost converter-voltage source inverter combination. *Energy* 2019, 166, 326–334. [CrossRef]
- [17] Zapata, J.W.; Kouro, S.; Carrasco, G.; Renaudineau, H.; Meynard, T.A. Analysis of partial power DC–DC converters for two-stage photovoltaic systems. *IEEE J. Emerg. Sel. Top. Power Electron.* 2018, 7, 591–603.[CrossRef]
- [18] Eswaramoorthy, K. "Study and performance analysis of hybrid bi tri dimensional space vector pulse width modulation for asymmetrical fifteen level inverter."
- [19] Del Moral, D.L.; Barrado, A.; Sanz, M.; Lázaro, A.; Zumel, P. AFZ converter: A new DC-DC topology applied to photovoltaic panels. In *Proceedings of the 2018 IEEE 19th Workshop on Control and Modeling for Power Electronics (COMPEL)*, Padua, Italy, 25–28 June 2018; pp. 1–6.
- [20] Thangam, Thomas, K. Muthuvel, and K. Eswaramoorthy. "SEPIC Converter with Closed Loop PI Controller for Grid Utilized PV System." *Journal of Next Generation Technology (JNxtGenTech)* 1, no. 1 (2021).
- [21] Ayop, R.; Tan, C.W. Design of boost converter based on maximum power point resistance for photovoltaic applications. *Sol. Energy* 2018, 160, 322–335. [CrossRef]
- [22] CHATTERJEE, SAYANTI, K. ESWARAMOORTHY, B. SINDHU, and G. CHAIRENJEEVI. "AN IMPROVED METHODOLOGY FOR LINEAR DESIGN OF LATERAL AUTOPILOT INCOMPLETE STATE FEEDBACK CONTROLLER USING POLE PLACEMENT METHOD." *Control Engineering* 7, no. 8: 9.

