



# INTERNATIONAL JOURNAL OF CREATIVE RESEARCH THOUGHTS (IJCRT)

An International Open Access, Peer-reviewed, Refereed Journal

## A STUDY ON CONSERVATION OF REVERSE OSMOSIS REJECT WATER BY RECLAMATION

<sup>1</sup>Palakbhai Patel, <sup>2</sup>Parth Modi, <sup>3</sup>Prabha Modi

<sup>1</sup>Student, <sup>2</sup>faculty, <sup>3</sup>Head of the department

<sup>1</sup>Chemical Engineering,

<sup>1</sup>Parul institute of engineering & technology diploma studies (PIET-DS), Vadodara, India

**Abstract:** Reuse of Waste or effluent water is largest problem in current scenario. About 60% of RO reject water is converted into effluent or in waste water because of major use of pure water in industries and of course for domestic purpose. Here, it is idea to use waste water or effluent water for further either in domestic use or in industrial use.

Major concern to use this effluent water contain is, high amount of heavy metal and Waste water effluents is limiting their regeneration and reuse after membrane treatments such as reverse osmosis (RO), Filtration. Presently it was removed by electro-coagulation or by electro dialysis but this process is used in limited because of high cost. Here, we are trying to remove heavy metals and impurities which are present in water by using chemical or by Solar distillation process or Natural agriculture waste which depend on type of water having number of impurities present in it.

With the help of additionally agriculture waste the cost of the treating water and the pollution also decrease.

### 1. INTRODUCTION

Now a days the crises of water are too much high, so that reuse of waste water is largest problem in current scenario. About 60% of raw water is converted into RO reject water and only 40% of water is used as a treated water. So, there are very big difference, in which and we observe that the RO reject which content considerable amount of water is directly throw out in drainage and there is too much wastage of Water are occurs in various places like in industries, in house hold and in institutes. So, the basically main problem is the wastage of RO reject water and we have to do for that. Freshwater scarcity and the excessive consumption of water have been regarded as serious challenges over past decades. Several contributing factors such as an increasing population, improving living standards, agricultural sector growth, and industrialization have threatened a Further reduction in the water level and given rise to this crisis. Based on the type of industry, A vast amount of wastewater containing salinity and organic compounds such as arsenic, fluoride Cadmium, chromium, mercury, manganese, lead, etc., have been produced. Discharging these Contaminant elements above their effluent standard has exerted catastrophic effects on aquatic and Terrestrial habitats and human health. To address this issue, several treatment technologies Have been investigated by scientists such as reverse osmosis, disinfection, granular filtration, Gravity separation, coagulation-flocculation, air stripping and aeration ion exchange, adsorption, And membrane filtration. Among all the conventional techniques under study, the distillation Process can be an accuracy due to the potential benefits associatedwith the technology.

And also, in the rapid increase in industrial activities during the last decades has caused severe changes in the environment. This development has led to contaminants such as heavy metals nutrient ions and dyes. Mining, mineral processing, and metallurgical operation generate a considerable amount of polluted water containing toxic heavy metals, which are almost persistent and non-degradable in nature in turn cause adverse effects in theenvironment. Therefore, the treatment of these waste waters becomes necessary before being discharged into the environment and river water streams, respectively.

Accordingly, in life of the facts, treatment of RO reject water, heavy metals containing industrial effluent becomes quite necessary before being discharged into the environment. The scientists and environmental engineers facing a tough of cost-effective treatment of wastewater.in which the conventional methods used for purifications are not more effective,It consumes high cost and require high energy. They are associated with generation of toxicsludge, which renders it expensive and non-ecofriendly in nature.

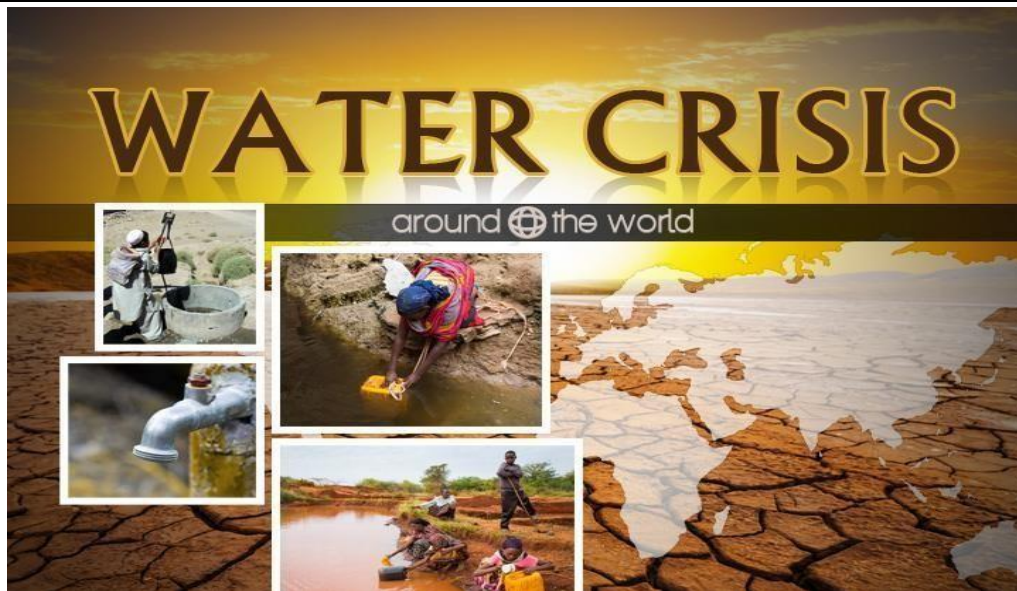

Fig 1: - overview of water crisis

So that for overcome this very big problem in industry as well as commercial purpose and all locality, for the purification the water basically, we use two different method (1) solardistillation (2) water purification by agriculture waste material. These methods are different from all the method and has too many advantages and application with cost effective analysis we seen in detailed in further.

## 2. Proposed methodology: -

Raw material used in the process: -

For process (1): -

1. RO reject water
2. Solar panel
3. Heating mental
4. Round bottom three neck flask
5. Thermometer
6. Spiral wound condenser
7. Connecting flask
8. stand

For process (2): -

1. Settling tank
2. Magnesium sulphate
3. Alum
4. Rise husk
5. Banana pills
6. Coconut husk
7. Filter bed

## 3. Solar distillation (process 1): -

We know that the solar energy is the most abundant source of energy and according to taking benefit of this energy, and on the basis of crises of water we collaborate this both matter into a beneficial method.

The biggest problem on this earth is the purification of the water, so we concern one portion of this, that is RO reject water, now a days the RO system is most widely used in all the spaces like, in industry, residential area and all commercial areas, in short where human being are present they most probably used this system to treat the water, not all human being used but mostly used, it is profitable to use but in which the main drawback is the About 60% of raw water is converted into RO reject water and only 40% of water is used as a treated water.

For treating this RO reject water for the reusing purpose and a special for the residential and collages & school this process 1 is most preferable to use, and for the industrial purpose we also developed process 2 it is not necessary but depend upon the impurities we can use one of them from this method.

So that in this method (process 1) we collect the RO reject through the pipelines in the overhead tank this overhead tank is also manufacture by the special material and this tank is also called as collection tank because this tank collects the RO reject water or else raw water which we have to purify.

After that from the bottom of the tank the water is passed through the pipe and in in the three-neck round bottom flask, this flask is situated on the heating mental. Heating mental is used for the heating the three-neck round bottom flask about 100 degrees Celsius, and the heating mental is used solar energy for the heating the flask.

Once the heating is starting the raw water is getting boiled and at 100 degrees Celsius the water is get vaporized and the heavy metal & impurities present in it they left at bottom, and the temperature of the flask is measured through the thermometer.

Now the vaporized water is passed in the spiral wound condenser, this is also an important part of this process in which the circulation of cold water or coolant is done through the outer side of the condenser so that the water vapor is condensed and we get again the water drop.

We collect the condensed water in the collecting flask, and we get pure water in this, after that this collected pure water is we passed or circular through different places according to their need.



Fig: -2overview of solar distillation process 1

In this process wastage of water is zero percentage and it is ecofriendly process, the pollution of the process is negligible. In this process high utilization and recovery of water are possible.

### 3.1 Experimental work of solar distillation: -

### 3.2 Solar energy utilization: -

Solar system has the advantages of cost saving over other types of energy utilization, because other energy is limitless and easily available and likewise seawater is readily available, there is an abundance of these sources. solar system has proved to be highly effective for energy savings as well as ecofriendly to the environment.

**3.3 Solar cell design: -**

The prototype of solar powered cell is made of inexpensive materials. The operation of this device is simple. The different feature of this device is unique. Feature such as modular design and water depth regulating system is notable.

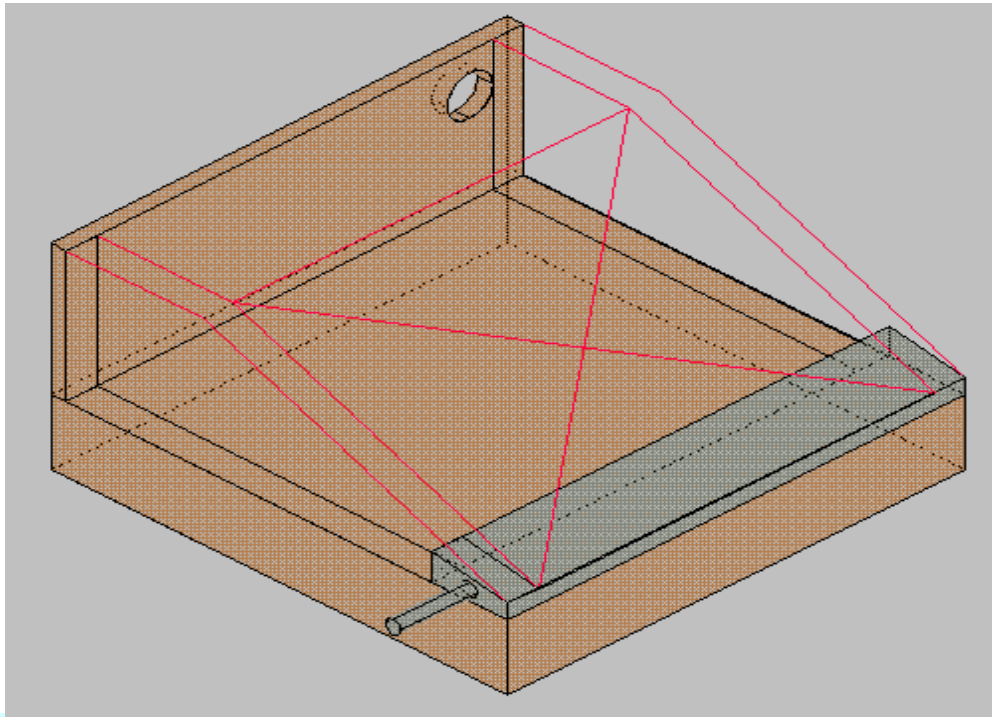

Fig: -3 Schematic diagram of solar cell

The first section of solar cell device is basin area, it is where the solar radiation is being absorbed to produce heat. The area of the basin depends on the desired output. Usually, it is recommended to produce 2 to 4 gallons of water.

**3.4 Calculation of solar system: -**

Solar panel watts \* average hours of sunlight \* 75% = daily watt hours.

Let's say you have 2000 watt solar panels and live in a place where you get 6 hour of sunlight per day. what's that 75% for? that's to account for all those variables we have been going over.

2000-watt x 6hour x .75=9000 daily watt hours

**3.5 Types of solar cell: -**

Table: -1 types of solar cell

Solar cell type	Efficiency	Advantage
Monocrystalline solar panels (MONO-SIO)	~20%	High efficiency rate; optimized for commercial; high life-time value
Polycrystalline solar panels (p-si)	~15%	Lower price
Thin-film: Amorphous silicon solar panels(A-SI)	~7-10%	Relatively low cost; easy to produce & flexible
Concentrated PV cell(cvp)	~41%	Very high performance & efficiency rate

**4. RO reject water purification by using agriculture waste material (process 2): -**

Sometime in small industries where water purification process is not possible so that place, this process is very useful to treat the water, and this process also important for the industries where the heavy metals present in the reject water.

Basically, in small scale industry they don't have water purification plant so they sell to the common ETP plant and they pay high amount for that, so these types of industry & other places where the RO water is used, this process are very applicable.

In this process the cost of the purification is also low as well as pollution also decrease, additionally we use agriculture waste material so that farmers also get benefit from two side in which the first is the garbage problem of waste material is solved and second is they also earn money by selling this material.

For this process firstly we collect the RO reject water in sedimentation tank, sedimentation tank is also known as settling tank, this type of tank made from special material depend upon impurities present in the water.

In this tank once the RO reject water is feed then after we do some chemical treatment in which we add some chemical like magnesium sulfate for the making alkaline water and then add alum in tis water then stirred this water and then put itfor the settle the water for 6 to 8 hours.

After that from the above portion of the tank, the water is passed through the pipe infilter bed.

Now we make different filter medium by using agriculture waste material like ricehusk, banana pills, maize cornel, coconut husk, etc.

We also use charcoal for the adsorbing the heavy metal like silica, lead, calcium, dyeetc. by using this material pretreatment like burning of coconut husk, rice husk is necessary.

Once the ash of agriculture waste materials is done then it is applicable to feed inthe filter bed.

In the filter bed deferent layer of material are fed and then passed water from the topand then from the bottom of the bed we get the pure water.

And then this water is again used in the industry and for the other purpose.

This process is also very important according the impurities present in the water andtypes of industry both method we use very well.

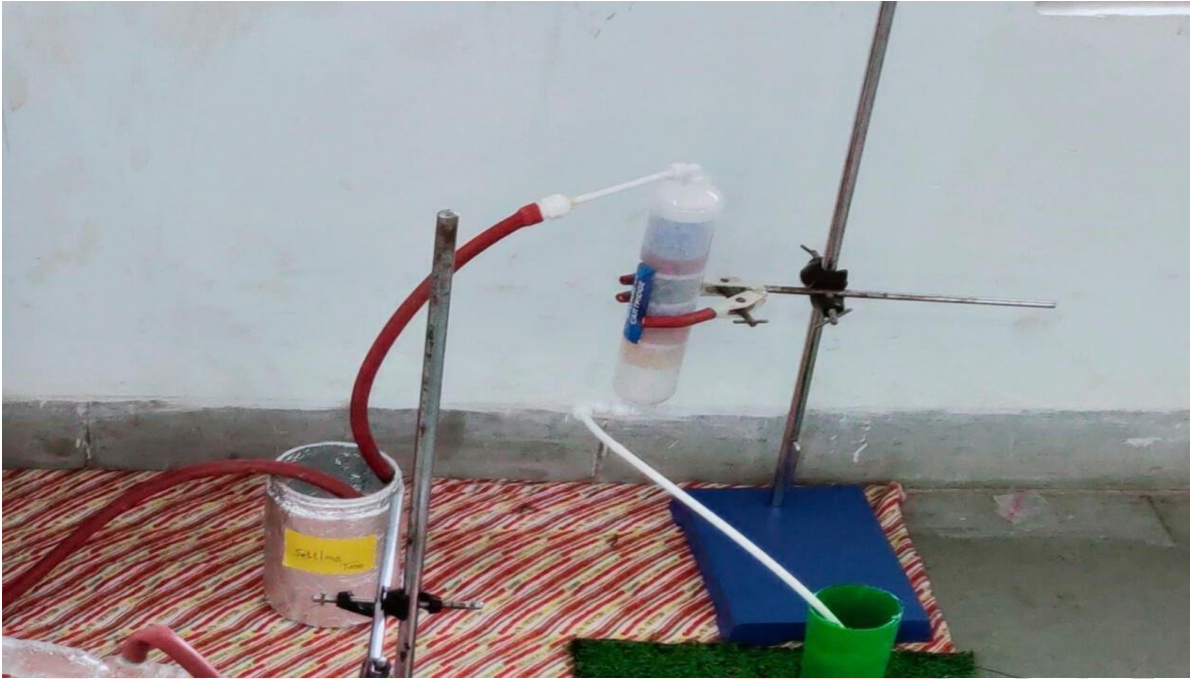

fig: - 4By using agriculture waste material (process2)

## 5. RESULTS AND DISCUSSION

### 5.1 Result of solar distillation: -

Our main concern is the reduced of the water impurities which is measure in the TDS,so the after the completion of the process we get the maximum TDS reduced water. if we have 188tds of raw water then after the completion of process we get 10tds of water.



Fig: - 5TDS of raw water



Fig: - 6TDS of purified water

Here this is to clarify that the result of this process is obtained by this method.

### 5.2 Result of by using agriculture waste material as a filter bed: -

This method is also very useful when the not highly pure water is required, in this process the purify water are not too much clean but it reduced the heavy metal & impurities present in it, if the raw water contain 200 to 200 TDS then the product water contain less than 60 TDS of water.

### 6. ACKNOWLEDGMENT

I take this opportunity to express my deep sense of gratitude to my guide MRS. PRABHA MODI for this valuable and untiring guidance, support and the confidence she placed in us throughout this project, which lead to the completion of work. I could not have imagined a better adviser and mentor. Her vast knowledge perceptiveness was invaluable throughout this work. Her guidance in shaping this project was indispensable and made the work a great learning experience for me.

I sincerely thank MR PARTH MODI for their guidance and encouragement in carrying out this work.

I would also like to extend my gratitude to the principal mam PROF. RUCHI SHRIVASTAVA for providing me with all the facility that was required.

I also wish to express my gratitude to the officials and other staff members of parul university who rendered their help during the period of our project work.

I am extremely thankful to our lab assistance sir MR KAMLESH SOLNKI for their support and always help us to perform our work.

At last, but not least gratitude goes to all of my friends who directly or indirectly helped us to complete this work.

Above all, to the great almighty, the writer of knowledge and wisdom, for his countless love. thank you.

### 7. REFERENCES

- 1) Sampathkumar k. Active solar distillation. Renewable and sustainable reviews, volume 14, 2010.
- 2) Islam s. & Uddin m. Water distillation method using solar power, International Conference on Mechanical Engineering and Renewable Energy, 2015.
- 3) Thaci B. & Gashi S. Reverse osmosis of Heavy Metals from Wastewater Effluents Using Bio Waste Materials Pre-treatment. Environ. Stud. 28(1), 2019
- 4) Nikhil B. & Ramesh S. Analysis & Treatment of Reverse Osmosis (RO) Reject from Dye Industries Using Anaerobic Baffled Reactor. Rasayan. 10(4), 2017.
- 5) Latour I. & Miranda R. Silica Removal in Industrial Effluents with High Silica Content and Low Hardness. Environmental Science and pollution Research. 9(3), 2014
- 6) kumar N. & Bhardwaj V. Ro Reject Water Management Techniques. World News Of Natural Sciences. 14(1), 2017.
- 7) Virapan . saravanane R. Treatment of reverse osmosis reject water from industries.
- 8) International journal of applied environmental sciences. Vol, 12 , 2017.