



# INTERNATIONAL JOURNAL OF CREATIVE RESEARCH THOUGHTS (IJCRT)

An International Open Access, Peer-reviewed, Refereed Journal

## A Review: Seismic Performance Analysis of Multistoried R.C.C. Flat Slab varying with Slenderness Ratio and Aspect Ratio

Sandeep Gaikwad<sup>1</sup>, Mahesh Nakade<sup>2</sup> Professor<sup>1</sup>, PG Student<sup>2</sup>

Department of Civil Engineering

Tulsiramji Gaikwad-Patil College of Engineering & Technology, Nagpur, Maharashtra, India

### Abstract:

Flat-slab building structures possess major advantages over traditional slab-beam-column structures because of the free design of space, shorter construction time, architectural –functional and economical aspects. Because of the absence of deep beams and shear walls, flat-slab structural system is significantly more flexible for lateral loads than traditional RC frame system and that makes the system more vulnerable under seismic events. The critical moment in design of these systems is the slab-column connection, i.e., the shear force in the slab at the connection, which should retain its bearing capacity even at maximal displacements. The behavior of flat slab building during earthquake depends critically on ‘Building Configuration’. This fact has resulted in to ensure safety against earthquake forces of tall structures hence, there is need to determine seismic responses of such building for designing earthquake resistant structures. Response Spectrum analysis is one of the important techniques for structural seismic analysis. In the present work dynamic analysis of 15 models of multi-storied RCC Flat slab structure is carried out by response spectrum analysis. The BIS guideline in IS 1893:2002 {Clause 7.1} says “Regular and Irregular Configuration to perform well in an earthquake, a building should possess four main attributes, namely simple and regular configuration, and adequate lateral strength, stiffness and ductility. Buildings having simple regular geometry and uniformly distributed mass and stiffness in plan as well as in elevation, suffer much less damage than buildings with irregular configurations”. Similarly, in IS 4326:1993 {Clause 4.4.1} it is mentioned that “The building should have a simple rectangular plan and be symmetrical both with respect to mass and rigidity so that the center of mass and rigidity of the building coincide with each other.” But the limiting “plan aspect ratio” and “Slenderness ratio” for the regular structure is not prescribed. This study is concerned with the behavior of structure having same plan area but different plan aspect ratio (L/B) and slenderness ratio (H/B) under seismic condition. The structures are simulated in ETABS 13 software and analyzed using Response Spectrum method.

**KEYWORDS** Aspect Ratio, Slenderness Ratio, Response Spectrum Analysis, Drift, Displacement, Storey shear, SMRF R.C.C. flat slab structure.

### I. INTRODUCTION

A slab is a flat, two dimensional, planar structural element having thickness small compared to its other two dimensions. It provides a working flat surface or a covering shelter in buildings. It supports mainly transverse loads and transfers them to support primarily by bending element just like flat plate. Common practice of design and construction is to support the slabs by beams and support the beams by columns. This may be called as beam-slab construction. The beams reduce the available net clear ceiling height. Hence in warehouses, offices and public halls sometimes beams are avoided and slabs are directly supported by columns. These types of construction are aesthetically appealing also. These slabs which are directly supported by columns are called Flat Slabs. minimized if the threat of terrorist action cannot be stopped. Designing the structures to be fully blast resistant is not a realistic and economical option, however current engineering and architectural knowledge

can enhance the new and existing buildings to mitigate the effects of an explosion.

#### Components of flat slab

##### Column Strip:

Column strip means a design strip having a width of  $0.25L_2$ , but not greater than  $0.25L_1$ , on each side of the column center-line, where  $L_1$  is the span in the direction moments are being determined, measured center to center of supports and  $L_2$  is the span transverse to  $L_1$  measured center to center of supports.

##### Middle Strip:

Middle strip means a design strip bounded on each of its opposite sides by the column strip. Panel:

Panel is defined as a part of a slab bounded on each of its four sides by the center-line of a Column or center-lines of adjacent-spans.

**Drops:**

The drops when provided shall be rectangular in plan, and have a length in each direction not less than one-third of the panel length in that direction. For exterior panels, the width of drops at right angles to the non-continuous edge and measured from the centerline of the columns shall be equal to one-half the width of drop for interior panels.

**Column Head:**

Where column heads are provided, that portion of a column head which lies within the largest right circular cone or pyramid that has a vertex angle of  $90^\circ$  and can be included entirely within the outlines of the column and the column head, shall be considered for design purposes.

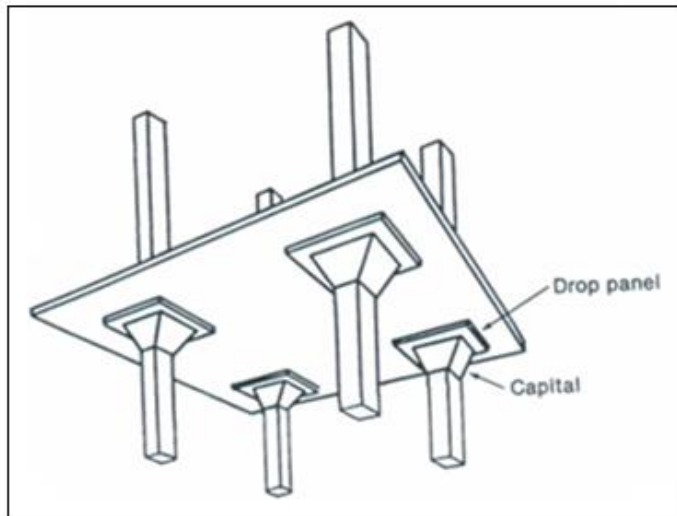

**Fig 1. Flat slab with drop and column head**(<https://www.google.co.in>)

Because of the absence of deep beams and shear walls, flat-slab structural system is significantly more flexible for lateral loads than traditional RC frame system and that make the system more vulnerable under seismic events. The critical moment in design of these systems is the slab-column connection, i.e. the shear force in the slab at the connection, which should retain its bearing capacity even at maximal displacements. The behavior of flat slab building during earthquake depends critically on 'Building Configuration'. This fact has resulted in to ensure safety against earthquake force of tall structures hence, there is need to determine seismic responses of such building for designing earthquake resistant structures.

**OBJECTIVE OF THE DISSERTATION**

A detailed literature review is carried out to define the objectives of the thesis.

Based on the literature review presented later, the salient objectives of the present study have been identified as follows:

- To perform parametric study on behavior of multi storied R.C.C. flat slab structure having same plan area but different plan aspect ratio ( $L/B$ ) and slenderness ratio ( $H/B$ ), under seismic condition.

- To perform analysis using Response Spectrum analysis.

To study the behavior of structure situated in seismic Zone IV.

To study effect on structure due to change in aspect ratio and change in slenderness ratio for structure, under seismic condition by observing results of analysis.

**II. LITERATURE REVIEW**

The seismic response of regular and irregular building had been the subject of numerous research papers. Following is a brief review of the work that has been done on topics which relates our study:

- Rucha S. Banginwar and M. R. Vyawahare,(2012) "**Effect of Plans Configurations on the Seismic Behaviour of the Structure By Response Spectrum Method**"

The study is carried on the effect of different geometrical configurations on the behaviour of structure of the already constructed building located in the same area during earthquake by Response spectrum method (RSM) in this paper, more emphasis is made on the plan configurations and is analysed by RSM since the RSM analysis provides key information for real – world application. In the present study the response (i.e. behaviour) of already constructed three buildings of college which are having different building geometric configuration in plan has been studied with the help of response spectrum method and at the end out of these three buildings, vulnerable building has been detected.

The conclusions of this study are briefly described as follows:

The plan configurations of structure have substantial impact on the seismic response of structure in terms of lateral deformation and storey shear.

Effect of area on Storey shear; it was observed that the storey shear in 'T' shape building was more though the irregularity in the plan configuration was less as compared to 'V' shaped building.

Torsion- Torsion was observed only in 'V' shaped building as the level of irregularity is maximum. The building is symmetrical about one axis but the orientation of block is oblique.

- Displacement – Large displacement were observed in the 'V' shape building and least displacement were observed in rectangular building. It indicates that building with severe irregularity shows maximum displacement and storey drift.

K S Sable (2012), "**Comparative Study of Seismic Behaviour of Multi-storey Flat Slab and Conventional Reinforced Concrete Framed Structures**"

This paper presents a summary of the study, for conventional R.C.C framed structure building and flat slab building for different floor height. The effect of seismic load has been studied for the two types of building by changing overall height of structure. On the basis of the results obtained in this study, following conclusions have been drawn:

- The natural time period increases as the height of building (No. of stories) increases, irrespective of type of building viz. conventional structure, flat slab structure and flat slab with shear wall. However, the time period is same for flat slab structure and flat slab with shear wall.
- In comparison of the conventional R.C.C. building to flat slab building, the time period is more for conventional building than flat slab building because of monolithic construction.
- For conventional building, average response acceleration coefficient decreases with increase in the height of building, however, for, flat slab structure and flat slab with shear wall, this change is not significant because in both structures less members are stiffened.
- For all the structure, base shear increases as the height increases. This increase in base shear is gradual up to 9th -storey, thereafter, it increases significantly gives rise to further investigation on the topic.
- Base shear of conventional R.C.C building is less than the flat slab building.
- Storey drift in buildings with flat slab construction is considerably more as compared to conventional R.C.C building. This influences moment which is developed during earthquake. In flat slab construction additional moments are developed. Thus, the columns of such buildings should be designed by considering additional moment caused by the Storey drift.

### 3. Arun Solomon (2013) "Limitation of irregular structure for seismic response"

In this study, non-linear behaviour of irregular structures. Because of the limitations of available size and shape of land for construction of buildings some of the structures become highly irregular as too long and too tall. The intension of this study was to identify the limitations of the too long and too tall structures using the software SAP 2000.

Author's aim was to show structure having regular building configuration behaves like irregular structure when it is too long and too tall regular structure by performing non-linear analysis (Pushover analysis).

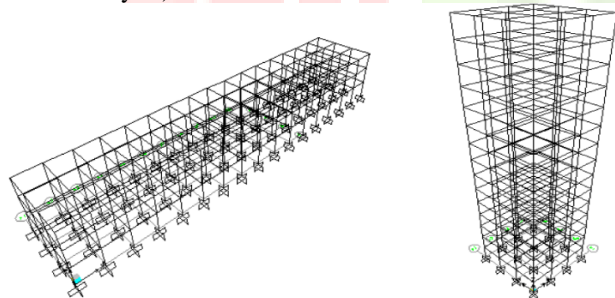

Figure 2: (a) Typical Too long Structure model (b) Typical too tall structures model[3]

From the investigation on the two types of too long structures the following results are obtained. The aspect ratio of the building is

1. Type I Building aspect Ratio (85/15) = 5.66.
2. Type II Building aspect Ratio (145/25) = 5.8

Author has concluded that the too long structures does not meet the performance limit if one of the plan dimension of the structure go beyond 5.6 times of another dimension, the building. Hence such types of too long buildings should be avoided while constructing in earthquake prone areas.

From the study on too tall structure the subsequent result is obtained by author. If the slenderness ratio of the building is

$(92/15) = 6.13$  then a too tall structure does not meet the performance limit if the structure's slenderness ratio exceeds. Mohit Sharma, SavitaMaru, (2014) "Dynamic Analysis of Multi-storied Regular Building"

The present works (problem taken) are on a G+30 storied R.C.C. framed structure building with regular configuration. The structure have the plan dimension of 25m x 45m with a floor to floor height as 3.6m for each storey and depth of foundation is 2.4 m. Total height of chosen building model including depth of foundation comes around 114 m. The static and dynamic analysis has done on computer with the help of STAAD-Pro software using the parameters for the design as per the IS-1893- 2002-Part-1 for the zones- 2 and 3 and the post processing result obtained has summarized.

R.C.C frame structure is analysed both statically and dynamically and the results are compared for the following three categories namely Axial Forces, Torsion and Moment at different beams and beam-column joints (nodes). The conclusion given by author are as follows:

Difference in the values of Axial Forces as obtained by Static and Dynamic Analysis of the R.C.C Structure was negligible.

Values for Torsion at different points in the beam are negative and for Dynamic Analysis the values for Torsion are positive.

Values for Moment at different points in the beam are 10 to 15% higher for Dynamic Analysis than the values obtained for Static Analysis for the Moment at the same points.

Displacement at different points in the lateral force resisting structure i.e. R.C.C. frame is 17 to 28 % higher for Dynamic Analysis than the values obtained for Static Analysis for the displacement at the same points.

## SEISMIC CODES BY BIS.

### Significance of Seismic Design Codes

Ground vibrations during earthquakes cause forces and deformations in structures. Structures need to be designed to withstand such forces and deformations. Seismic codes help to improve the behaviour of structures so that they may with stand the earthquake effects without significant loss of life and property. Countries around the world have procedures outlined in seismic codes to help design engineers in the planning, designing, detailing and constructing of structures. An earthquake-resistant building has four virtues in it, namely:

- a) Good Structural Configuration: Its size, shape and structural system carrying loads are such that they ensure a direct and smooth flow of inertia forces to the ground.
  - b) Lateral Strength: The maximum lateral (horizontal) force that it can resist is such that the damage induced in it does not result in collapse.
  - c) Adequate Stiffness: Its lateral load resisting system is such that the earthquake-induced deformations in it do not damage its contents under low-to moderate shaking.
- Good Ductility: Its capacity to undergo large deformations under severe earthquake shaking even after yielding is improved by favourable design and detailing strategies. Seismic codes cover all these aspects.

## BUILDING CONFIGURATION

### Dynamic Actions on Buildings

Dynamic actions are caused on buildings due to *earthquakes*. In earthquake resistant design, we consider that the building is subjected to random motion of the ground at its base, which induces inertia forces in the building that in turn cause stresses; this is called *displacement-type* loading.

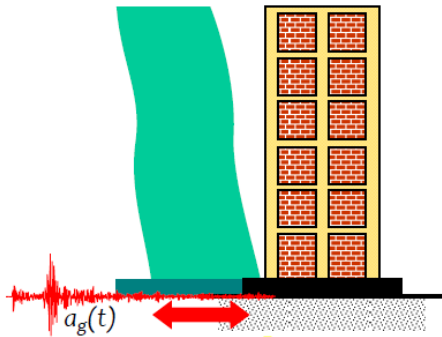

Fig. 3 Dynamic actions due to earthquake[2]

The motion of the ground during the earthquake is cyclic about the neutral position of the structure. Thus, the stresses in the building due to seismic actions undergo many complete reversals and that too, over the small duration of earthquake.

### Basic Aspects Of Seismic Design

The mass of the building being designed controls seismic design in addition to the building stiffness, because earthquake induces inertia forces that are proportional to the building mass. Designing buildings to behave elastically during earthquakes without damage may render the project economically unviable. As a consequence, it may be necessary for the structure to undergo damage and thereby dissipate the energy input to it during the earthquake. Therefore, the traditional earthquake-resistant design philosophy requires that normal buildings should be able to resist (Figure 4):

- a) Minor (and frequent) shaking with no damage to structural and non-structural elements;
- b) Moderate shaking with minor damage to structural elements, and some damage to non-structural elements; and
- c) Severe (and infrequent) shaking with damage to structural elements, but with NO collapse (to save life and property inside/adjoining the building).

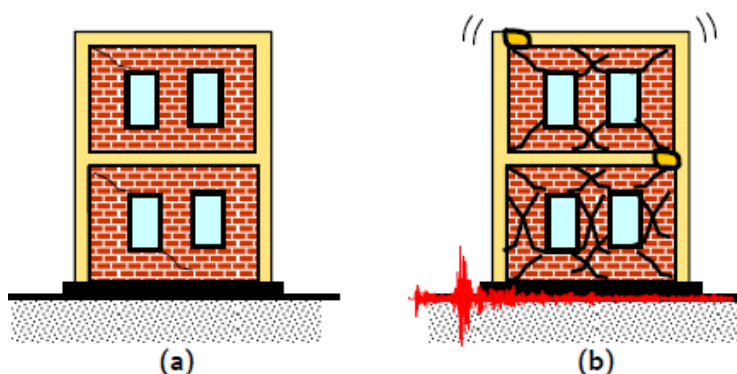

Fig. 4 Effect of Minor, Moderate and Sever shaking with

Therefore, buildings are designed only for a fraction (~8-14%) of the force that they would experience, if they were designed to remain elastic during the expected strong ground shaking, and thereby permitting damage. But, sufficient initial stiffness is required to be ensured to avoid structural damage under minor shaking. Thus, seismic design balances reduced cost and acceptable damage, to make the project viable. This careful balance is arrived based on extensive research and detailed post-earthquake damage assessment studies.

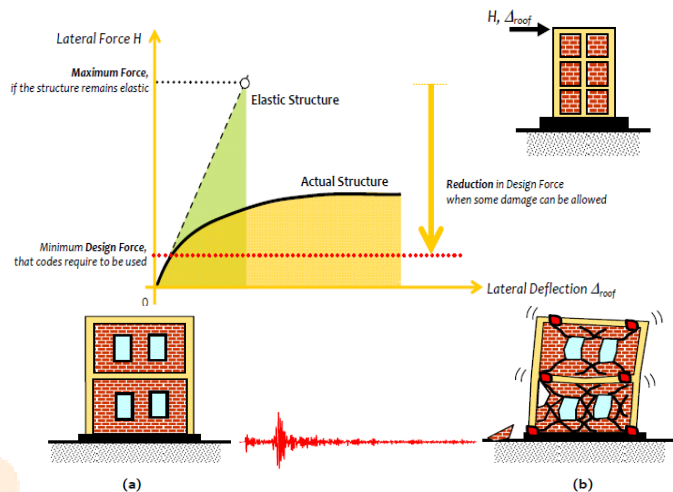

Fig. 5 Graphical representation showing variation in lateral displacement at roof level with respect to lateral force[2]

### The Four Virtues of Earthquake Resistant Buildings

All buildings are vertical cantilevers projecting out from the earth's surface. Hence, when the earth shakes, these cantilevers experience whiplash effects, especially when the shaking is violent. Hence, special care is required to protect them from this jerky movement. Buildings intended to be earthquake-resistant have competing demands. Firstly, buildings become expensive, if designed not to sustain any damage during strong earthquake shaking. Secondly, they should be strong enough to not sustain any damage during weak earthquake shaking. Thirdly, they should be stiff enough to not swing too much, even during weak earthquakes. And, fourthly, they should not collapse during the expected strong earthquake shaking to be sustained by them even with significant structural damage. These competing demands are accommodated in buildings intended to be earth quake resistant by incorporating four desirable characteristics in them. These characteristics, called the four virtues of earthquake-resistant buildings, are:

1. Good seismic configuration, with no choices of architectural form of the building that is detrimental to good earthquake performance and that does not introduce newer complexities in the building behaviour than what the earthquake is already imposing;

At least a minimum lateral stiffness in each of its plan directions (uniformly distributed in both plan directions of the building), so that there is no discomfort to occupants of the building and no damage to contents of the building;

At least a minimum lateral strength in each of its plan directions (uniformly distributed in both plan directions of the building), to resist low intensity ground shaking with no damage, and not too strong to keep the cost of construction in check, along with a minimum vertical strength to be able to continue to support the gravity load and thereby prevent collapse under strong earthquake

shaking; and

4. Good overall ductility in it to accommodate the imposed lateral deformation between the base and the roof of the building, along with the desired mechanism of behaviour at ultimate stage.

Behaviour of buildings during earthquakes depends critically on these four virtues. Even if any one of these is not ensured, the performance of the building is expected to be poor.

### Modeling of Structural

Element Beam and columns are modeled as frame elements available in ETABS 15 structural analysis software, with central lines joined at nodes. Column slab joint are considered as rigid slab-column joints. The floor slabs are assumed to act as diaphragms, which ensure integral action of all the vertical lateral load resisting elements. The weight of the slab was distributed as shell load distribution. The columns ends are fixed. A response spectrum analysis applied for analysis of all the 25 models.

### Method Of Analysis

The Present Study Done for the Below Mentioned Analysis  
**Equivalent static analysis Method**

#### Response spectrum method.

The steps undertaken in the present study to achieve the above-mentioned objectives area follows:

- Carry out extensive literature review, to establish the objectives of the research work.
- Select an exhaustive set of R.C.C. flat slab building models with different number of storey (4 to 12 storeys), Aspect ratio (1to 5) in plan and constant plan area. (900 m<sup>2</sup> )
- Perform Response Spectrum Analysis for each of the 25 models.
- Analyse and compare the result obtained from response spectrum analysis of models which are base shear, storey drift, stiffness, natural time period, and frequency of earthquake. Drop from the slab to the column at it support.
- To resist this negative moment the area at the support needs to be increased, this is facilitated by providing column capital/heads flat slab.
- The drops when provided shall be rectangular in plan.
- To resist the punching shear which is predominant at the contact of slab and column Support, the drop dimension should not be less than one -third of panel length in that direction

#### Equivalent static analysis:

All design against seismic loads must consider the dynamic nature of the load. However, for simple regular structures, analysis by equivalent linear static methods is sufficient. This is permitted in most codes of practice for regular, low- to medium-rise buildings. This procedure does not require dynamic analysis, however, it account for the dynamics of building in an approximate manner. The static method is the simplest one-it requires less computational efforts and is based on formulate given in the code of practice. First, the design base shear is computed for the whole building, and it is then distributed along the height of the building. The lateral forces at each floor levels thus obtained are distributed to individual's lateral load resisting elements.

### III. CONCLUSION

Following conclusions were derived as a result of the study performed throughout work: As per discussion of results we conclude that there is marginal reduction in Displacement, by introducing shear wall. But the Displacement is reduced by introducing shear wall at corner along both directions.

1. For earthquake as per IS 1893-1-2002CL:7.11.1 page no 27, Maximum drift limitation of 0.004 as per IS code is satisfied for all the Shear Wall Models of the building using Elcentro earth quake.
2. Changing the position of shear wall will affect the attraction of forces, so that wall must be in proper position.
3. If the dimensions of shear wall are large then major amount of horizontal forces are taken by shear wall.
4. Providing shear walls at adequate locations substantially reduces the displacements due to earthquake.

#### IV. REFERENCES

- [1] K S Sable, V A Ghodechor, S B Kandekar, "Comparative Study of Seismic Behavior of Multi-storey Flat Slab and Conventional Reinforced Concrete Framed Structures", International Journal of Computer Technology and Electronics Engineering (IJCTEE) Volume 2, Issue 3, June 2012
- [2] Rucha.S.Banginwar, M.R.Vyawahare, P.O.Modani, "Effect of Plan Configurations on the Seismic Behaviour of the structure By Response Spectrum Method" ,International Journal of Engineering Research and Applications(IJERA),Vol2,May-June2012
- [3] Arun Solomon A, Hemalatha G, "Limitation of irregular structure for seismic response", International Journal Of Civil And Structural Engineering Volume 3, No 3, 2013
- [4] Mohit Sharma and SavitaMaru(2014), "Dynamic Analysis of Multistoried Regular Building" , Journal of Mechanical and Civil Engineering (IOSR-JMCE), Volume 11, Issue 1 Ver. II.
- [5] Mayuri D. Bhagwatand.P.S.Patil(2014), "Comparative study of performance of rccmultiSTOREY building for Koyna and Bhuj earthquakes", International Journal of Advanced Technology in Engineering and Science Volume No.02, Issue No. 07.
- [6] V.L. Shah and S.R. Karve, "Illustrated design of reinforced concrete buildings", Sixth edition, Structures publications, 36 Parvati, Pune-411009.

