



SHEAR STRENGTH OF CFS CHANNEL EDGE STIFFENED AT WEB HOLE

¹Sandra Raphy, ²Sreedevi Bhasin, ³Lakshmi Priya K P

^{1,2}PG Students, Department of Civil Engineering, Universal Engineering College Irinjalakuda, Thrissur, Kerala, India,

³Assistant Professor, Department of Civil Engineering, Universal Engineering College Irinjalakuda, Thrissur, Kerala, India

Abstract: The study focus on the performance evaluation of CFS channels edge stiffened at web hole under the influence of combined bending and shear. Nonlinear simulations of shear test are performed using finite element method based package ANSYS 16.1. The parameters of the study are edge stiffened length and its fillet radius. Various characteristics such as shear stiffness and failure mode are also discussed with the help of shear strength- displacement curves obtained from ANSYS 16.1. From the analysis results, the model with 12mm edge stiffened length and 4mm fillet radius has the maximum shear strength and shear stiffness.

Index Terms – Cold formed steel (CFS), Edge Stiffener, Shear Strength, Shear Stiffness.

1. INTRODUCTION

Cold-formed steel channels are manufactured with perforations for minimizing the effects of service systems on ceiling clearance height and internal architecture by providing access for building service systems through web holes. The applications of CFS members includes the buildings, bridges, car bodies, storage tanks, highway products, railway coaches, transmission towers, drainage facilities, etc. The thin-walled steel members have the thicknesses varying between 0.4 mm to 7 mm. The steel plates and steel bars of thickness 25.4 mm can also be molded into required cold formed structural shapes. The manufacturing process of CFS involves forming the material by either press-braking or cold roll forming to get the desired shape. In comparison to the hot rolled section with the cold rolled sections, CFS have more moment of inertia and section modulus in x-direction and y-direction, therefore the load carrying capacity and moment resisting capacity are higher. The aim of the study is to evaluate shear strength of perforated channels edge stiffened at web hole and select the best model by changing the edge stiffener length and its fillet radius. CFS channel sections with web hole has reduction in shear strength. The web holes are stiffened through continuous edge stiffener around the perimeter of hole.

This paper presents an analytical investigation on shear behaviour of CFS lipped channel sections with varying edge stiffened length and fillet radius using newly designed dual actuator test rig. The dual actuator test rig minimizes applied bending moments along the shear span, thus allowing ultimate shear strengths to be reached without premature flexural failures. The shear strength and deformation patterns of CFS lipped channel with aspect ratio 4.2 are reported.

1.1 Objectives of the Project

- To model and analysis CFS perforated channels using dual actuator test set up.
- To evaluate the shear strength of CFS channels with varying edge stiffened length with different fillet radius.

2. MODEL DETAILS

The analysis on channels (C20015) with 100 mm web hole comprised of nine models on 200 mm deep and 1.5 mm thick G450 lipped channel sections with varying edge stiffened length and fillet radius at web hole. Term G450 refers to a steel grade which has a guaranteed minimum yield strength of 450 MPa. Fig.1 shows the dimension notation of C channels with stiffened holes. Length of flange (b_f) is 75mm, depth of the channel (h_o) is 200mm, total width of the lip (d_o) is 15mm and the thickness of the channel section (t) is 1.5mm. Diameter of edge stiffened hole (a) is 100mm, r_q denotes the fillet radius and q denotes the edge stiffened length.

Fig.2 illustrates the test setup, a cantilevered cold-formed steel channel is bolted to stocky column by moment connection using high strength M12 bolts on web and M10 bolts on flanges. Two channel bolted back to back to two sides of 20mm thick loading plates. In order to approach predominantly shear behaviour and obtain the shear strength close to pure shear capacity, the loads were transferred from the two actuators to the cantilever cold formed steel beam via loading plates with proper independent movement rates of actuators, so that pair of equal and opposite sign bending moments at two ends of the shear span is produced. Bolted connections were used to connect the beam specimens with the loading plates and thick plates welded to a

stocky column which is designed to produce a fix support at one end of cantilever beam specimens. Two actuators transferred load to beam webs using 5 rows of M12 high strength bolt. The 5 rows of bolt in web allow full tension field action in shear span to developed and the bolt group on flange ensure the connection was able to carry moments. To prevent the flange from distortion four pair of 30 x30 x3EA straps were provided to both top and bottom flange.

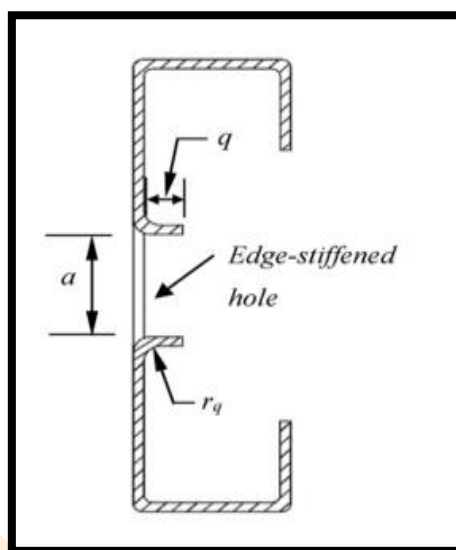

Fig.1 Dimension Notations for CFS Channels Stiffened at Web Hole

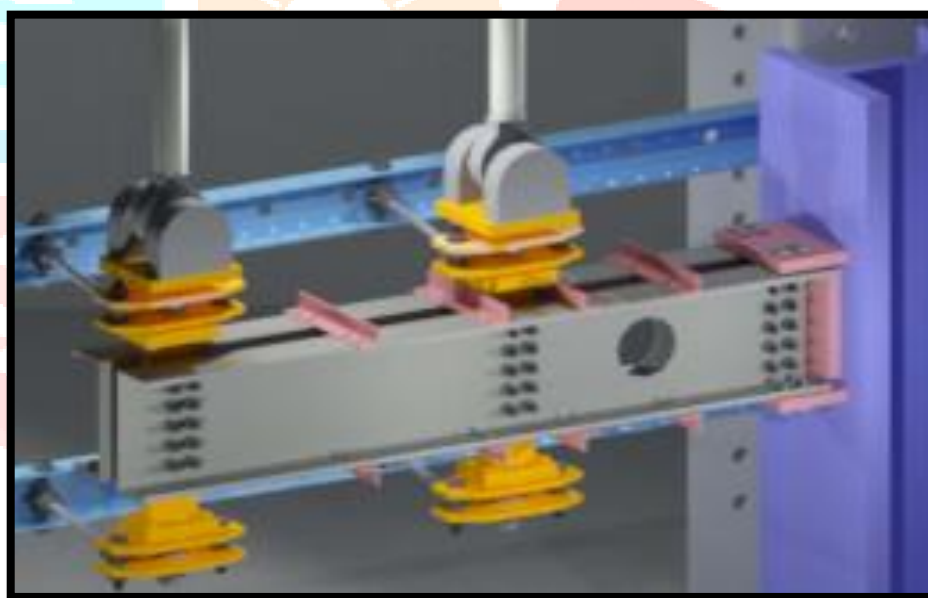

Fig.2 Test Setup

3. MODELLING AND ANALYSIS

ANSYS Workbench 16.1 was used to develop the three-dimensional model and nonlinear simulations were conducted. Shear behaviour of CFS perforated channels are analyzed.

Shell 181 in ANSYS were chosen to model CFS. It is proven to be reliable in capturing the post buckling behaviour of thin walled section. Solid 185 were selected to model other compounds including columns, plates, straps. Because of symmetry of 2 channels, only one channel is modeled and assigned the symmetric boundary condition. The beam length equals to 1534mm, shear span 838mm and aspect ratio 4.2.

The engineering properties which were input to the elastic material property in channel element are young's modulus (E) of 206228 MPa, yield strength (F_y) of 450 Mpa and Poisson's ratio of 0.3. For other hot-rolled components including the stocky column, thick plates, loading plates and straps, Young's modulus of 200000 MPa, Yield strength 365 Mpa and Poisson's ratio of 0.3 were used for elasticity material property.

Mesh size of 5mm was utilized to model, and for circular web opening the area surrounding the holes were partitioned to provide a sweep mesh. Boundary condition restraining all DOF were employed to generate a fixity at column base and transfer of loads was simulated through vertical displacements applied by actuator on loading plates. Fig-3 shows the 3D model of the specimen with its boundary conditions.

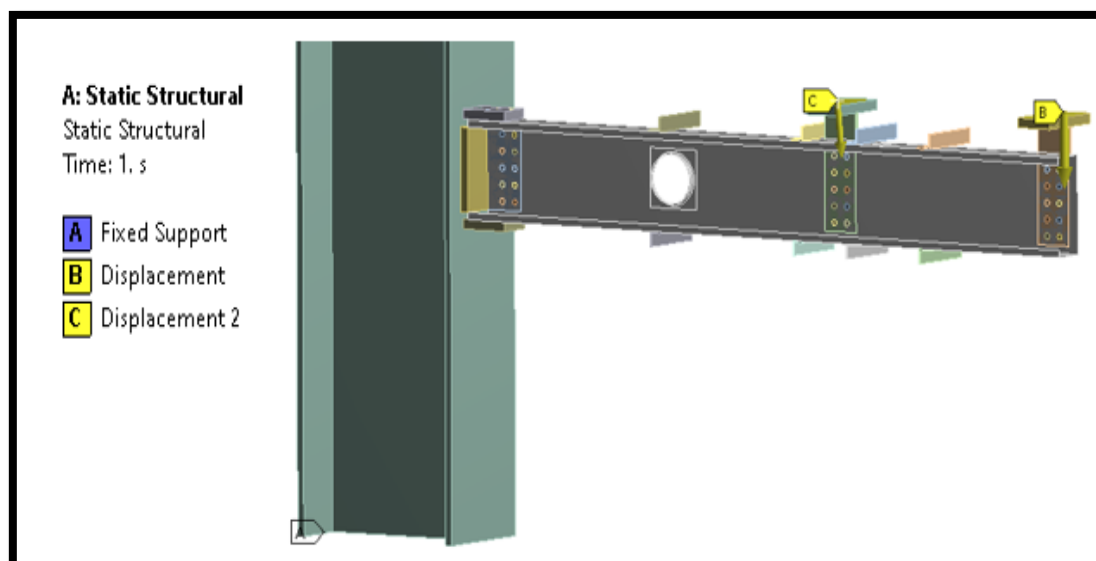

Fig.3 3D Model of the Specimen with its Boundary Conditions

3.1 Ultimate Shear Strength Analysis of Perforated CFS Channel with Stiffened Web Hole

The analysis is conducted on the beam length equals to 1534mm, shear span 838mm and aspect ratio 4.2 with edge stiffened web hole. The ratio of length of stiffener to depth of section is taken as 0.04, 0.06, 0.08 with the varying fillet radius 2mm, 4mm, 6mm. Fig.4 shows the geometry of CFS with edge stiffened at web hole. Fig.5 illustrates the total deformation of the model CFS4-C20015-12ES4. 12ES4 indicates the edge stiffener with 12mm edge stiffened length and fillet radius 4mm. The total deformation by ultimate shear strength analysis with the corresponding color scale charts is displayed on the FE models.

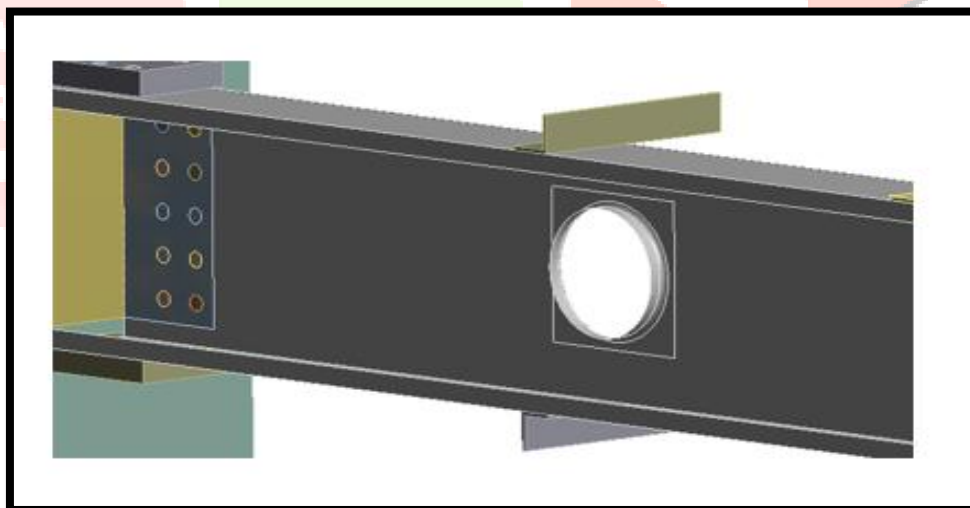

Fig.4 Geometry of CFS with Edge Stiffened at web hole

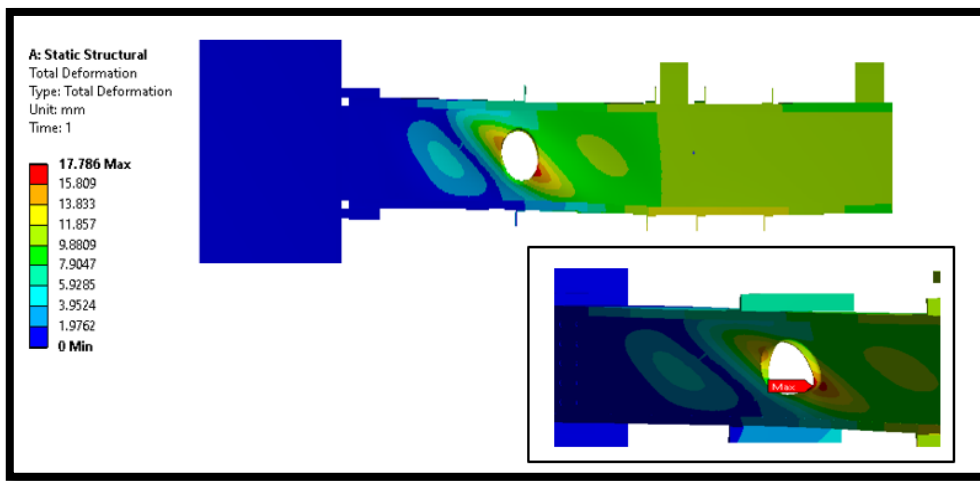

Fig.5 Total Deformation of CFS with Edge Stiffener

4. RESULTS AND DISCUSSION

Ultimate shear strength analysis for CFS channels with aspect ratio by varying edge stiffened length and fillet radius, results shows that the model with 12mm edge stiffened length and 4mm fillet radius has the maximum shear strength and shear stiffness. The shear strength – displacement curve for different edge stiffened length and fillet radius obtained from this study are shown in fig.6. Ratio (Q) of length of stiffener (q) to depth of flat portion of web (h) were 0.04, 0.06, 0.08 and fillet radius (r_q) of end stiffener is 2mm, 4mm, 6mm.

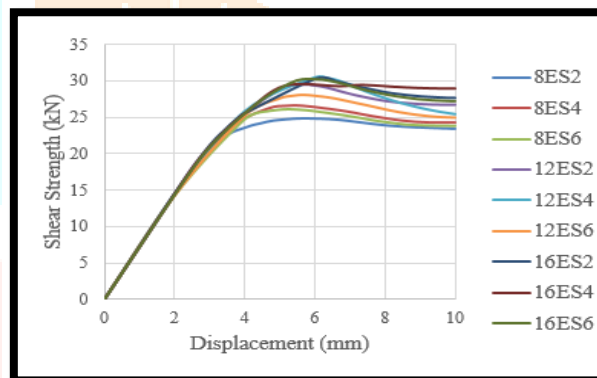

Fig.6 Shear Strength – Displacement curve for CFS Channels with Edge Stiffened at web holes

Table 1 Calculation of Shear Stiffness for CFS Channels with Edge Stiffened at web holes

Model	Q	Fillet Radius (r_q) (mm)	Shear Strength V_n (kN)	Displacement (mm)	Shear Stiffness (kN/mm)
CFS4-C20015-8ES2	0.04	2	24.82	5.66	4.38
CFS4-C20015-8ES4	0.04	4	26.56	5.65	4.70
CFS4-C20015-8ES6	0.04	6	26.10	5.19	5.03
CFS4-C20015-12ES2	0.06	2	29.48	5.93	4.97
CFS4-C20015-12ES4	0.06	4	30.46	6.00	5.08
CFS4-C20015-12ES6	0.06	6	28.16	5.70	4.94
CFS4-C20015-16ES2	0.08	2	30.41	6.05	5.03
CFS4-C20015-16ES4	0.08	4	29.46	7.28	4.05
CFS4-C20015-16ES6	0.08	6	30.22	6.11	4.95

The following equation shows the shear stiffness of CFS channel,

$$\text{Shear Stiffness} = \frac{\text{Shear Strength}}{\text{Displacement}} \quad \text{Eq.1}$$

By the values of shear strength and displacement obtained from the analysis the shear stiffness is calculated. Table-1 illustrates the calculated values of shear stiffness and Fig.6 shows the diagram with variations in shear stiffness.

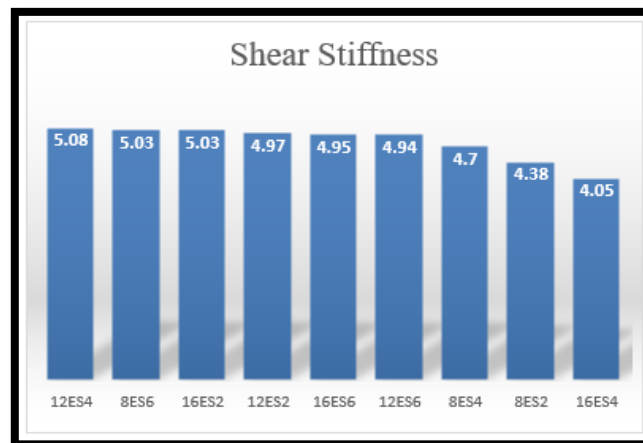

Fig-6 Variations in Shear Stiffness

5. CONCLUSIONS

The wide application of high strength cold-formed steel in building construction is attributed to high strength-to-weight ratio, ease of prefabrication, easy and fast erection and installation compared to conventional hot-rolled steel.

From the analysis of CFS with edge stiffened web hole under the influence of combined bending and shear, it is observed that there is 15%-17% variations are present in each analysis and max deformation is occurred at the edge stiffener. The channel with edge stiffened length 12mm and fillet radius 4mm performed better than other models with varying edge stiffened length and fillet radius.

REFERENCES

- [1] Asraf Uzzaman et.al. 2020. Web crippling behaviour of cold-formed steel channel sections with edge-stiffened and un-stiffened circular holes under interior-two-flange loading condition. *Thin-walled structures*, 154:106-813
- [2] Boshan Chena, et. al. 2020. Axial strength of back-to-back cold-formed steel channels with edge-stiffened holes, un-stiffened holes and plain webs. *Journal of Constructional Steel Research*, 174:106-313.
- [3] Cao Hung Pham, 2017. Shear Buckling of Plates and Thin-walled Channel Sections with Holes. *Journal of Constructional Steel Research*, 128: 800–811.
- [4] Poologanathan Keerthan, et. al. 2013. Experimental Studies of the Shear Behaviour and Strength of Lipped Channel Beams with Web Openings. *Thin-Walled Structures*, 73:131–144.
- [5] Song Hong Pham, et. al. 2020. Shear Strength Experiments and Design of Cold-Formed Steel Channels with Web Holes. *Journal of Structural Engineering*, 146(1): 1-14.
- [6] Song Hong Pham, et. al. 2018. Experimental Study of Shear Strength of Cold-formed Channels with an Aspect Ratio of 2.0. *Journal of Constructional Steel Research*, 149:141–152.