



## DC MOTOR SPEED AND DIRECTION CONTROL USING ANDROID

Ch. V. Ganesh<sup>1</sup>, G Suryaprakash Reddy<sup>2</sup>, Rajashree<sup>3</sup>, Goudelli Akash Kumar<sup>4</sup>

(Assistant professor<sup>1</sup>; UG scholars<sup>2,3,4</sup>)

Department of EEE, ST. Peters Engineer College, Hyderabad, Telangana. India.

### Abstract:

The technology is a process that never ends and to improve the quality of any product these technologies are required. The Android is the most popular mobile platform, which is very useful in creating much real time application which is useful in our day to day life. Under this article, the blueprint and execution of a cheap, robust as well as resilient and secure Bluetooth based DC motor speed and direction control has been presented. The speed control was implemented using Bluetooth technology to provide communication access from smart phone. On the other hand we have PIC platform that we can use to quickly prototype electronic systems. IR sensor is used to measure the RPM of DC motor. By using PWM signal we can control the DC motor. Android mobile act as a transmitter and the received by Bluetooth receiver interfaced to PIC which send data to the Bluetooth module and which in-turn run the DC motor and also monitor the speed of DC motor on LCD module.

### Keywords:

PIC micro controller, LCD, Bluetooth, IR sensor, DC motors.

### 1. Introduction:

Speed controlling of DC motors plays a very crucial role. Monitoring and controlling of speed of a DC motor by using Android Smart phones have involved the Bluetooth technology, so and outer Bluetooth module HC05 is interfaced with the PIC microcontroller unit for the wireless connection. The Bluetooth module obtains signal from the smartphone mobile android app. Therefore, according to the I/P signal, with the using of PIC, IR sensor can be usually used to vary the speed as well as for the DC motor by using PWM techniques. Direct Current motor

direction can also be varied with the using of driver circuit or Hodge Bridge network.

The electric drive systems should possess some benchmark properties like linear control, reliability and steady operation. DC driven machines gain some advantage in these aspects. The speed control methods of DC motor plays a vital role in the performance of drive. The main purpose of speed controller is to focus on how we can use Bluetooth based device to control speed and direction of a DC motor at a desired speed and the main objective of dc drive is to maintain a system with the stable speed irrespective of load condition. In this paper, we describe a recently developed "Android based speed control of DC motor", a smart phone control experimental setup that can be accessed via the Bluetooth. This setup consists of two basic primary elements communicating with each other: i) Bluetooth of smart phone which is connected to the microcontroller, IC and DC Motor interfaced with a motor driver IC and ii) a Bluetooth module. The smart phone sends/receives data to/from the microcontroller using the wireless technology via Bluetooth. An application based on Android is created and downloaded in the phone which acts as a display panel for the user to send/receive/view the input and output of the DC motor. In this paper visual display of the current position of the motor using sensors can be sent by the microcontroller to the smart phone. Our microcontroller-based remote control methodology using an android based smart phone can be readily applied and control the speed of DC motor through it.

### 2. LITERATURE SURVEY:

I. In the paper of N.Barsoum, simple technique is used to control the speed of DC motor by sending SMS from mobile phone. The GSM module will receive SMS of desired motor speed in RPM send by the user. SMS received on the GSM module

will be proceed by MCU and MCU will convert the SMS into suitable duty cycle for PWM pulse to control the speed of the DC motor. MCU is programmed to continuously send an AT command to the GSM module to check for message in the SIM every 5 second at location 1. Program will go to next step after receiving the message after that, MCU will receive the SMS, extract the speed & change it to a suitable duty cycle for the PWM.

II. In this paper, Abhishek Khanna & Priya Rajan have described “Android based speed control of DC motor via Bluetooth”. In this system, a motor driver IC L293D that is interfaced with the microcontroller Arduino Uno controls a dc motor. Two basic elements that are Bluetooth of mobile phone, which is connected to Arduino Uno microcontroller & a Bluetooth module communication with each other. The data is sent by the smart phone to the microcontroller via Bluetooth. A 12V solar panel or a 12V adaptor is used to power the entire system. This solar panel converts solar energy into electrical signals directly or indirectly through photovoltaic (PV) and concentrated solar power (CSP). To concentrate large area of sunlight on solar panels, lenses, tracking system and mirrors can be used. This project is cost effective and eco-friendly as it uses the solar panels as a power source. This system can be integrated with robotics, drones, house door, lockers etc.[5].

### 3. HARDWARE IMPLEMENTATION:

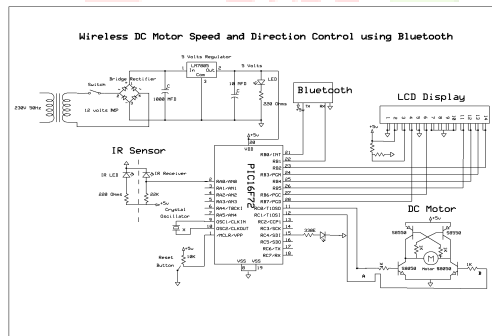

Fig: circuit diagram

Wireless DC Motor Speed and Direction Control using Bluetooth

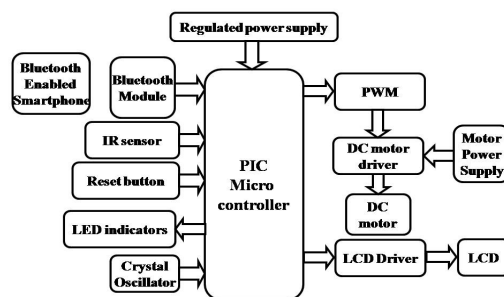

Fig: Block diagram of Wireless Dc Motor Speed and Direction Control Using Bluetooth

The main blocks of this paper are: Regulated power supply, PIC Microcontroller, Reset, DC motors, Bluetooth receiver module, IR sensor, LCD.

This project makes use of a PIC micro controller, which is programmed, with the help of embedded C instructions. This PIC Microcontroller is capable of communicating with input and output modules. DC motor along with driver and Bluetooth module is interfaced to the microcontroller. When the user presses the buttons on his Bluetooth enabled smart phone, this data is received by Bluetooth module and transmit this data to the PIC microcontroller then microcontroller control the DC motor accordingly. In achieving the task the controller is loaded with a program written using Embedded 'C' language. We can see the values of varied speed and direction on LCD. IR sensor is used to measure the RPM of DC motor. By using PWM signal we can control the DC motor.

The android application in the mobile phone is developed with the help of Android Studio Software.

A pulse width modulator (PWM) is a device that may be used as an efficient DC motor speed controller. This project is a versatile device that can control DC devices which draw up to a few amps of current. The circuit may be used in either 12 or 24 Volt systems with only a few minor wiring changes. This device has been used to control the speed of the DC motor and to control brightness of an automotive tail lamp. A PWM circuit works by making a square wave with a variable on-to-off ratio, the average on time may be varied from 0 to 100 percent. In this manner, a variable amount of power is transferred to the load.

### 4. Related Work:

The brief introduction of different modules used in this project is discussed below:

#### 4.1. Bluetooth Module:

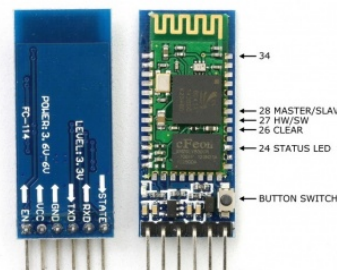

Fig: Bluetooth module

'Bluetooth', the short-range radio link technology designed to "connect" an array of devices including mobile phones, PC's, and PDA's, and the strategic decisions that Motorola should make in incorporating this nascent technology into its product portfolio. The purpose of this paper will be to provide a high-level overview of the technology to the head of Motorola's Communications Enterprise, and prepare this corporate officer to be strategically and functionally conversant in the technology with subordinates that have direct responsibility for integrating Bluetooth into Motorola's product lines. The Bluetooth module HC-05 is a MASTER/SLAVE module. By default the factory setting is SLAVE. The Role of the module (Master or Slave) can be configured only by AT COMMANDS. The slave modules cannot initiate a connection to another Bluetooth device, but can accept connections. Master module can initiate a connection to other devices.

### Hardware Features

- Typical -80dBm sensitivity.
- Up to +4dBm RF transmit power.
- 3.3 to 5 V I/O.
- PIO(Programmable Input/Output) control.
- UART interface with programmable baud rate.
- With integrated antenna.
- With edge connector.

### 4.2. DC Motor:

A dc motor uses electrical energy to produce mechanical energy, very generally through the interaction of magnetic fields and current-containing conductors. The reverse process, producing electrical energy from mechanical energy, is carried out by an alternator, source or dynamo. Many types of electric motors can be run as sources, and vice versa. The input of a DC motor is current/voltage and its output is torque (speed).



Fig: DC Motor

The DC motor has two basic parts: the rotating part that is called the armature and the stable part that includes coils of wire called the field coils. The stationary part is also called up the stator. Figure shows a depict of a distinctive DC motor, Figure shows a picture of a DC armature, and Figure shows a picture of a distinctive stator. From the picture you can see the armature is made of coils of wire wrapped around the

core, and the core has an covered shaft that rotates on charges. You should also notice that the ends of each coil of wire on the armature are finished at one end of the armature. The outcome points are called the commutator, and this is where's brushes make electrical contact to bring electrical current from the stationary part to the rotating part of the machine.

### 4.3. 4.2. LCD Module:

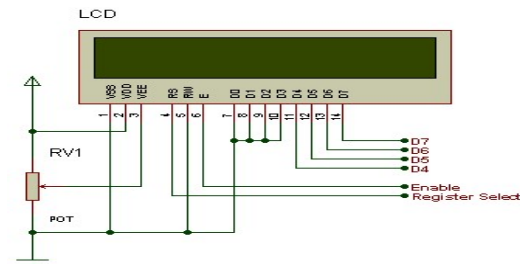

Fig: LCD

One of the most common devices attached to a micro controller is an LCD display. Some of the most common LCD's connected to the many microcontrollers are 16x2 displays. This means 16 characters per line by 2 lines respectively. In this project we are display the speed of the DC motor ON LCD module with help of IR sensor and PIC microcontroller.

### 4.4. PIC micro controller:



Fig: PIC micro controller

The PIC microcontroller features 5 channels of 8-bit Analog-to-Digital (A/D) converter with 2 additional timers, capture/compare/PWM function and the synchronous serial port can be configured as either 3-wire Serial Peripheral Interface (SPI™) or the 2-wire Inter-Integrated Circuit (I²C™) bus. All of these features make it ideal for more advanced level A/D applications in automotive, industrial, appliances and consumer applications. The hardware capabilities of PIC devices range from 6-pin SMD, 8-pin DIP chips up to 144-pin SMD chips, with discrete I/O pins, ADC and DAC modules, and communications ports such as UART, I2C, CAN, and even USB. PIC devices are popular with both industrial developers and hobbyists due to their low cost, wide availability, large user base, extensive collection of application notes, and availability of low cost or free development tools, serial



programming, and re-programmable flash-memory capability.

#### Peripheral Features:-

- High Sink/Source Current: 25 mA
- Timer0: 8-bit timer/counter with 8-bit pre-scaler
- Timer1: 16-bit timer/counter with pre-scaler, can be incremented during SLEEP via external crystal/clock
- Timer2: 8-bit timer/counter with 8-bit period register, pre-scaler and post-scaler
- Capture, Compare, PWM (CCP) module-Capture is 16-bit, max. resolution is 12.5 ns- Compare is 16-bit, max. resolution is 200 ns- PWM max. resolution is 10-bit
- 8-bit, 5-channel analog-to-digital converter
- Synchronous Serial Port (SSP) with SPI™ (Master/Slave) and I2C™ (Slave)
- Brown-out detection circuitry for Brown-out Reset (BOR)

#### 4.5. IR sensor:



Fig: IR sensor

The **IR sensor module** consists mainly of the **IR Transmitter** and **Receiver**, Opamp, Variable Resistor (Trimmer pot), output LED in brief. **IR LED Transmitter**. **IR LED** emits light, in the range of **Infrared** frequency. **IR** light is invisible to us as its wavelength (700nm – 1mm) is much higher than the visible light range. It has a range of about 10-15cm (4-6 inches) with my hand as the object being detected. In this project IR sensor is used to measure the RPM of DC motor.

#### 5. CONCLUSION:

Integrating features of all the hardware components used have been developed in it. Presence of every module has been reasoned out and placed carefully, thus contributing to the best working of the unit. Secondly, using highly advanced IC's with the help of growing technology, the project has been successfully implemented. Thus the idea of the paper has been successfully designed and tested. The paper presented “Wireless DC Motor Speed and

Direction Control using Bluetooth” was designed to operate a DC motor using PWM and controlling through Bluetooth module and the system able to monitor the motor speed on LCD display. IR sensor is used to measure the RPM of DC motor. By using PWM signal we can control the DC motor.

#### 6. FUTURE SCOPE

In future, apart from controlling the speed and direction of DC motors, the same technique can be implemented in both single phase and three phase AC motors as well. For long range wireless communication WIFI-module can be used. Touch screen technology can also be implemented. We can extend by adding IOT technology to this project which is used to detect and monitor the status like the speed and direction of the motor directly to the thing speak using Wi-Fi module. The system can also uses SR04 obstacle sensor for detection of speed and direction of the Motor more accurately. The drawback of this project is that the status of motor movement is not known. The main disadvantage of this project is that the person who is operating the appliances doesn't know the status of the DC motor. This drawback can be eliminated by introducing a GSM module, through which intimation on the status of DC motor can be sent from anywhere in the world. We can add GSM module, which gives the alerting messages in case of speed and direction of the motor with GSM module which gives respective information.

#### 7. ACKNOWLEDGEMENT

We would like to thank all the authors of different research papers referred during writing this paper. It was very knowledge gaining and helpful for the further research to be done in future.

#### 8. RESULTS:

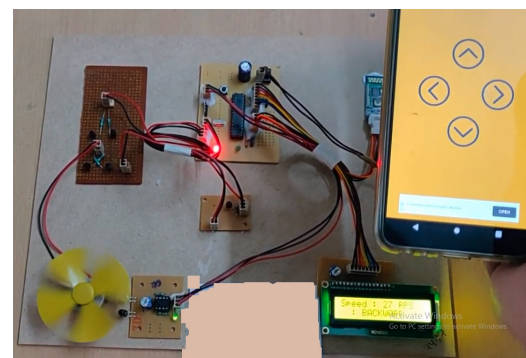

Fig: project output image

The paper presents the design of “Wireless DC Motor Speed and Direction Control using Bluetooth” was designed to operate a DC motor using PWM and controlling through Bluetooth module and the system able to monitor the motor speed on LCD display. IR sensor is used to measure the RPM of DC motor. By using PWM signal we can control the DC motor.

#### REFERENCES:

- [1]. Arindam Bhattacharjee, Gaurav Ghosh, Vijay Kumar Tayal, Pallavi Choudekar, “Speed Control of BLDC Motor through Mobile Application via Secured Bluetooth”, Recent Development Control & Power Engineering (RDCAPE), 2017.
- [2]. N.Barsoum,” DC motor speed control using SMS application, Journal of Intelligent Control and Automation 5”, 2012.
- [3]. Ritesh Chaubey, Deepak Kumar, Saketh, Dr. Sudeshna, “Speed & Direction Control of DC Motor using Android Mobile Application”, International Journal of Electrical Electronics & Computer Science Engineering .
- [4]. Ankesh N.Nichat, Sheikh Kadir Ali, Yogesh D. Solanke, Amit M.Dodke, “Wireless Speed and Direction Control of DC Motor by Using Radio Frequency Technology.
- [5]. A. Khanna and P. Ranjan, “Solar Powered Android Based Speed Control of DC Motor via Secure Bluetooth”, IEEE, 2015.
- [6]. V.J. Sivanagappa, K.Haribalan “Speed control of DC motor via Internet for Traction Applications” IEEE, 2016.
- [7] Bhattacharjee, et al., “Speed Control of BLDC Motor through Mobile Application via Secured Bluetooth”, Recent Developments in Control, Automation and Power Engineering, Noida, India, May 2018.
- [8] N. Barsoum, “DC motor speed control using SMS application”, Journal of Intelligent Control and Automation, vol. 5, no. 4, pp. 205-212, 2014.
- [9] R. Chaubey, et al., “Speed and Direction Control of DC Motor using Android Mobile Application”, International Journal of Electrical Electronics & Computer Science Engineering, pp. 101-102, 2018.
- [10] A. N. Nichat, et al., “Wireless Speed and Direction Control of DC Motor by Using Radio Frequency Technology”, International Journal of Engineering Trends and Technology, vol. 20, no. 2, pp. 48-51, Feb. 2015.
- [11] Khanna and P. Ranjan, “Solar Powered Android Based Speed Control of DC Motor via Secure Bluetooth”, 5 th International Conference on Communication Systems and Network Technologies, Gwalior, India, Oct. 2015.
- [12] V. J. Sivanagappa, K. Haribalan “Speed control of DC motor via Internet for Traction Applications”, International Conference on Energy Efficient Technologies for Sustainability, Nagercoil, India, Oct. 2016.
- [13] Abhishek Khanna, Priya Ranjan, “Solar-Powered Android-Based Speed Control of DC Motor via Secure Bluetooth”, Communication Systems and Network Technologies (CSNT), 2015 Fifth International Conference.
- [14] Dr. Anshuman Tyagi, Aman Shukla, Ambesh Yadav, Kamran Ahmad, Mohit Gupta, Mohit Shukla, “Speed Control of DC Motor Using Mobile Phone”, International Journal of Engineering Science and Computing, vol. 7 Issue No. 3, March 2017.
- [15] K.S.Varsha, P.SudharshanPalaniappan, S.Susmithaa, M.Prabhu Raj, “Speed and Direction Control of DC Motor using Android Mobile Application”, International Journal of Engineering Science and Computing, Volume-7 Issue No-3, March 2017.
- [16] K.S Ravi Kumar, Jaideep, Rohit, Vikas “Microprocessor Based Closed Loop Speed Control of DC Motor Using PWM”, International Conference on Control, Instrumentation, Communication and Computational Technologies (ICCICCT), 2015.

