



PV based FOPID Controlled Interleaved Boost Inverter

¹N. Pavan Kumar, M.E

¹ Assistant Professor & Head of the Department

¹ Department of Electrical and Electronics Engineering,

¹ Sanskrithi School of Engineering, Puttaparthi, Andhra Pradesh, India

ABSTRACT: PV based FOPID controlled Interleaved boost Inverter is a good choice between DC source and Both DC & AC load. This work deals with enhancement of response of three stage ILBC fed DC & AC drive system using FOPID controller. Closed loop ILBCDCM systems controlled by PI & FOPID are model and simulated. The results are presented for PI & FOPID controlled ILBC systems. The comparison of response is done in terms of settling time and steady state error in speed of ILBC. The results indicate that FOPID controlled ILBC gives better response than PI controlled ILBC system. Interleaved boost converter is a converter where boost converters are connected in parallel. The topology is used to increase the efficiency and reliability.

Keywords—Solar panel, Interleaved Boost Converter, Fuzzy Controller, Inverter, Ripple Reduction

I. INTRODUCTION

The Renewable energy being the best solution and employed all over the world to satisfy the energy shortage existing without environmental contamination. Among the renewable energies available the most promising energy is Photovoltaic (PV) energy. Though PV system installation cost is high, it has lots of pros, as the system is long lasting and maintenance free. Now-a-days, PV system has grasped the attention of the researchers, but high installation cost and low conversion efficiency are the major drawbacks. To extract maximum power from the PV system MPPT technique can be implemented to the boost converters. By adjusting the duty ratio of the converter, maximum power delivered can be tracked by the PV panel. As the energy generated by the PV system is not sufficient (i.e.) very low voltage. IN order to overcome, the aforementioned cons in the PV system. The DC/DC boost converter is employed in between the power generation stage and the load. The voltage is boosted and high voltage is achieved. But, our conventional power converter has low efficiency due to the poor conversion ratio. The semiconductor devices are used as the switch in the converter. Since, this switch suffers with voltage stress, the switching losses increases and efficiency is decreased.

The interleaving of converter doubles the voltage gain so that the efficiency can be increased further. Moreover, closed loop control provides better dynamic response and voltage regulation. Novel zero voltage transition PWM converters, soft-switching techniques applied to the PWM converters, with the exception of a few isolated cases, are subjected to either high switch voltage stresses or high switch current stresses. A new class of zero-voltage-transition PWM converters is proposed, where both the transistor and the rectifier operate with zero-voltage switching and are subjected to minimum voltage and current stresses.

A family of zero-voltage-transition (ZVT) pulse width-modulated converters with synchronous rectifier (SR) is introduced. The SR decreases the conduction losses, while it increases the achieved soft switching range. In this family of converters, zero-voltage-switching (ZVS) condition is attained for the main and rectifier switches. Also, zero-current switching is achieved for the auxiliary switch. In addition, the applied ZVS technique can eliminate the reverse recovery losses of the rectifier switch body diode. The work proposes FOPID for the closed loop control of ILBC system.

II. INTERLEAVED BOOST CONVERTER:

The Interleaved Boost Converter (IBC) consists of two boost converters connected in parallel with a 180° phase delay, and operating at the same frequency. The IBC has better characteristics when compared to a boost converter with improved efficiency, reduced size, greater reliability and lower Total Harmonic Distortions (THD). The gating pulses of the two switches in the converter are shifted by a phase difference of $360/n$ where n is the number of parallel boost converters. The converter considered is operating in Continuous Conduction Mode (CCM) which results in lower input peak current (amplitude) and less conduction losses. It operates at larger duty cycle say 0.5 due to high output voltage and low input voltage. The input current for the IBC is the sum of each inductor currents and as the two devices are phase shifted by 180° , the input current ripples are small.

The input is an unregulated DC voltage, which is obtained by rectifying line voltage. DCDC converters are switched mode DC to DC converter and are used to convert unregulated DC input to controlled DC output. The IBC consists of two boost converters in parallel with a phase delay of 180° operating in CCM mode. The converter uses two MOSFET switches, two inductors, two diodes, one capacitor and a resistive load.

The circuit diagram and the ideal waveforms of the currents in the inductors L_1 and L_2 for interleaved boost converter operating at CCM. When the device S_1 is turned ON, the current in the inductor i_{L1} increases linearly. During this period energy is stored in the inductor L_1 . When S_1 is turned OFF, diode D_1 conducts and the stored energy in the inductor ramps down with a slope based on the difference between the input and output voltage. The inductor starts to discharge and transfer the current via the diode to the load. After a half switching cycle of S_1 , S_2 is also turned ON completing the same cycle of events. Since both the power channels are combined at the output capacitor, the effective ripple frequency is twice than that of a single-phase boost converter. The amplitude of the input current ripple is small.

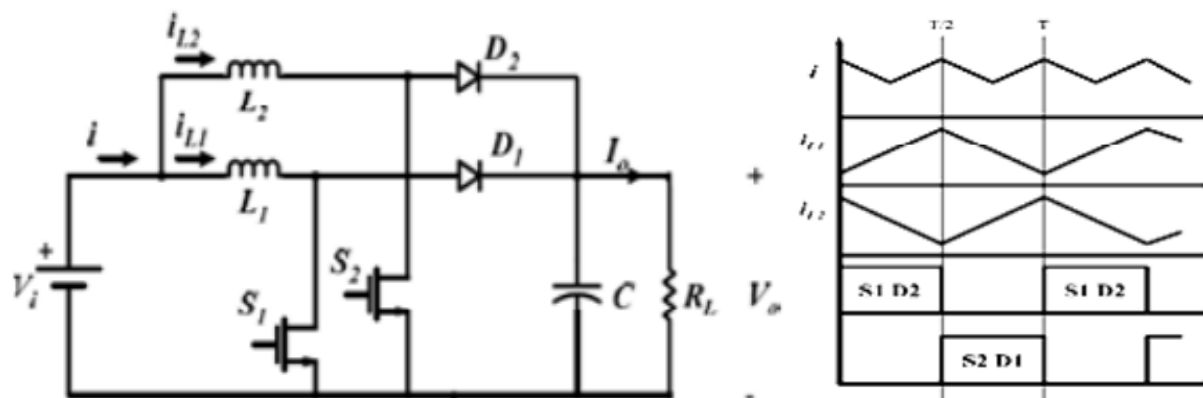

III. PROPOSED ILBC

DC from PV is boosted using DC to DC Converter. The output of boost converter is applied to DC load and Inverter system. Actual speed is sensed and it is compared with the reference speed. The error is applied to a FOPID controller. The output FOPID updates the pulse width applied to ILBC to regulate the output voltage.

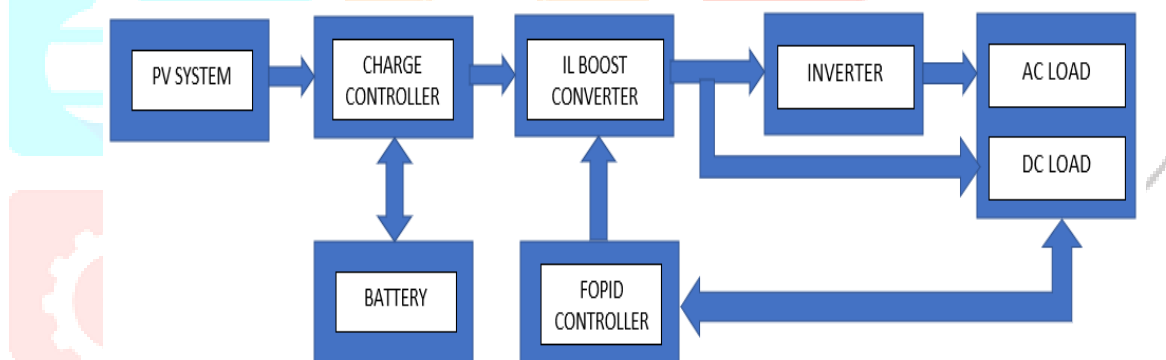

IV. FOPID CONTROLLER:

The PID controller remains the most popular due to its simplicity and clear physical interpretation of the controller parameters. Recently, there has been an extension of the conventional PID controller by substituting the orders of the derivative and integral components to any arbitrary real numbers instead of fixing those orders to one. The transfer function of an FOPID controller takes the form of. $C_{FOPID}(s)=K_p+K_i/s^\lambda + K_D s^\mu$. Where λ is the order of the integral part, μ is the order of the derivative part, while K_p , K_i , and K_D are the constants as in a conventional PID controller.

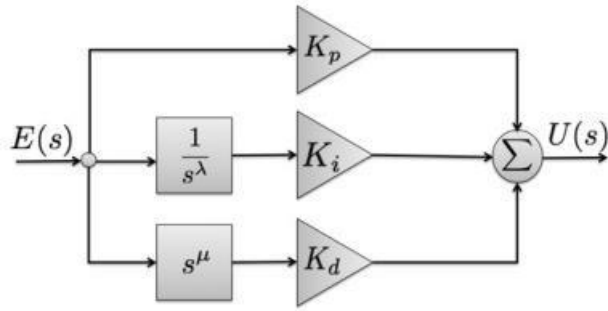
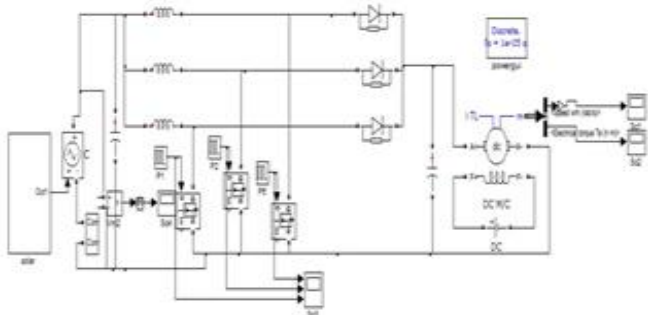

Figure Block Diagram of FOPID Controller

V. SIMULATION RESULTS

The open loop ILBC system with step change in input and the output of PV is boosted using three stage ILBC. The output of ILBC is applied to Both DC & AC Load. The input voltage is 170 V. The motor speed value is 1300 RPM. The Torque response value is 3 N-m. Higher starting torque is due to the high starting current.



Open Loop ILBCDCM System with Step Change in Input

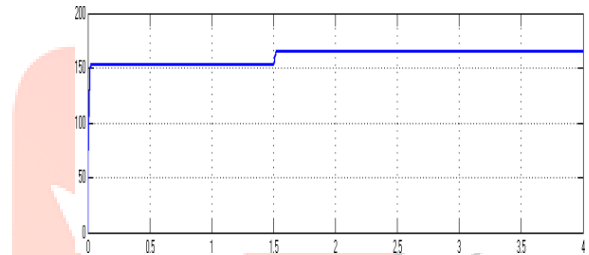

Input Voltage

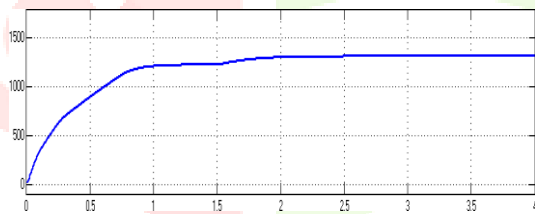

Motor Speed

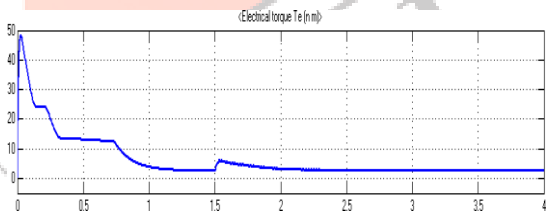

Torque Response

Closed loop ILBCDCM system with PI controller Actual speed is sensed and it is compared with the reference speed. The speed error is applied to a PI controller. The output of PI controller is compared with three repeating sequences displaced by 120°. The outputs of comparators are applied to the switches of TSILBC. The input voltage is shown in Fig 4.2 and its value is 170 V.

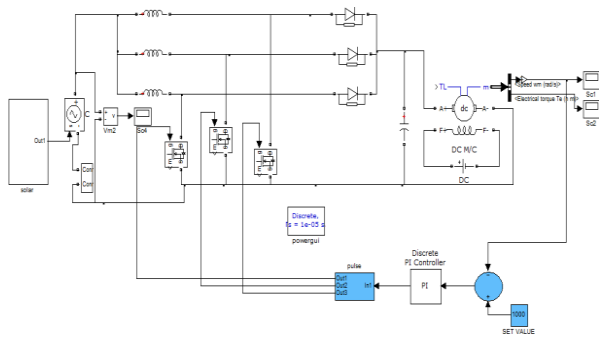

Closed Loop ILBCDCM System with PI Controller

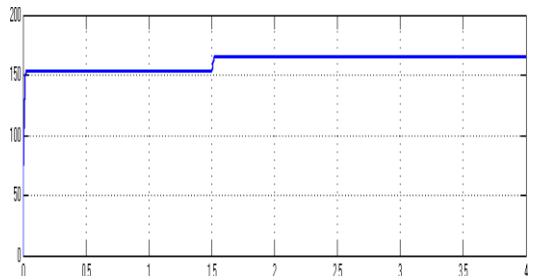

Input Voltage

The PI controller is replaced by FOPID controller. The input voltage is 170 V. The motor speed is 1000 RPM. The torque developed is 1N-m. The summary of time domain parameters of rise time is reduced from 1.52 to 1.51 sec, settling time is reduced from 2.4 to 1.6 sec and Peak time is reduced from 1.7 to 1.53 sec. The steadystate error is reduced from 2.7 to 1.3 V. It can be seen that the response with FOPID is faster than that of PI controlled system.

Time Domain Parameters

Controllers	t_r	t_s	t_p	E_{ss}
PI	1.52	2.4	1.7	2.7
FOPID	1.51	1.6	1.53	1.3

VI. CONCLUSION

Closed loop controlled ILBCDCM systems with PI and FOPID are modeled and simulated successfully. The results of comparison indicate that setting time is as low as 1.6 secs and steady state error is 1.3V with FOPID controller. Therefore FOPID controlled ILBCDCM has better dynamic response than other systems. The proposed system has advantages like reduced current ripple and improved response. The disadvantages of ILBCDCM are increased inertia and cost. The Scope of the present work is to compare the responses of PI & FOPID controlled ILBCDCM systems. The comparison between PI & PR controlled systems will be in future.

REFERENCES

- [1] J.T.Bialasiewicz, "Renewable energy systems with photovoltaic power generators: Operation and modelling" *IEEE Trans. Ind. Electron.*, vol.55, no.7, pp.2752-2758, Jul 2008.
- [2] C. M. Wang, "A new single-phase ZCS-PWM boost rectifier with high power factor and low conduction losses," *IEEE Trans. Ind. Electron.*, vol. 53, no. 2, pp. 500–510, Apr. 2006.
- [3] R.J.Wai and R.Y.Duan "High step up converter with coupled inductor," *IEEE Tran. Power Electron*, vol.20, no.5, pp 1025-1035, Sep 2005.
- [4] H. M. Suryawanshi, M. R. Ramteke, K. L. Thakre, and V. B. Borghate, "Unity-power-factor operation of three-phase AC-DC soft switched converter based on boost active clamp topology in modular approach," *IEEE Trans. Power Electron.*, vol. 23, no. 1, pp. 229–236, Jan. 2008
- [5] M.Chunting, M.B.R.Correa and J.O.P.Piinto "The IEEE 2011 international future energy challenge-request for proposals," in proc IFEC, 2010, pp.1-24.
- [6] C. J. Tseng and C. L. Chen, "A passive lossless snubber cell for nonisolated PWM DC/DC converters," *IEEE Trans. Ind. Electron.*, vol. 45, no. 4, pp. 593–601, Aug. 1998.
- [7] Y.-C. Hsieh, T.-C. Hsueh, and H.-C. Yen, "An interleaved boost converter with zero-voltage transition," *IEEE Trans. Power Electron.*, vol. 24, no. 4, pp. 973–978, Apr. 2009.
- [8] C. M. de Oliveira Stein, J. R. Pinheiro, and H. L. Hey, "A ZCT auxiliary commutation circuit for interleaved boost converters operating in critical conduction mode," *IEEE Trans. Power Electron.*, vol. 17, no. 6, pp. 954–962, Nov. 2002.
- [9] W. Li and X. He, "ZVT interleaved boost converters for high-efficiency, high step-up DC-DC conversion," *IET Electron. Power Appl.*, vol. 1, no. 2, pp. 284–290, Mar. 2007.
- [10] G. Yao, A. Chen, and X. He, "Soft switching circuit for interleaved boost converters," *IEEE Trans. Power Electron.*, vol. 22, no. 1, pp. 80–86, Jan. 2007.
- [11] Kirubakaran .D and Rama Reddy S. (2009), 'Closed loop controlled AC-AC converter for induction heating', *Journal of Industrial Technology*, USA, Vol. 25, No. 2, pp. 01-05
- [12] J. Yungtaek and M. M. Jovanovic, "Interleaved PFC boost converter with intrinsic voltage-doubler characteristic," in Proc. *IEEE Power Electron. Spec. Conf.*, Jun. 2006, pp. 1888–1894.
- [13] H.-Y. Tsai, T.-H. Hsia, and D. Chen, "A novel soft-switching bridgeless power factor correction circuit," in Proc. Eur. Conf. Power Electron. Appl., Sep. 2007, pp. 1–10.
- [14] S. S. Saha, B. Majumdar, T. Halder, and S. K. Biswas, "New fully softswitched boost-converter with reduced conduction losses," in Proc. IEEE Int. Conf. Power Electron. Drives Syst., 2005, vol. 1, pp. 107–112.
- [15] Sivakumar.J and SenthilNayagam.V "Implementation of Dual Active-Clamped Step-Up DC-DC Converter with Reduced Voltage Stress For Low-DC Renewable Energy Sources" "January 2013 PDCS012013 004
- [16] G. Hua, C.-S. Leu, Y. Jiang, and F. C. Y. Lee, "Novel zero-voltage transition PWM converters," *IEEE Trans. Power Electron.*, vol. 9, no. 2, pp. 213–219, Mar. 1994.
- [17] E. Adib and H. Farzanehfard, "Family of soft-switching PWM converters with current sharing in switches," *IEEE Trans. Power Electron.*, vol. 24, Analysis and Design of a Zero-Voltage-Switching and
- [18] E. Adib and H. Farzanehfard, "Zero-voltage-transition PWM converters with synchronous rectifier," *IEEE Trans. Power Electron.*, vol. 25, no. 1, pp. 105–110, Jan. 2010.
- [19] S.-H. Park, S.-R. Park, J.-S. Yu, Y.-C. Jung and C.-Y. Won, "Analysis and design of a soft-switching boost converter with an HI-bridge auxiliary resonant circuit," *IEEE Trans. Power Electron.*, vol. 25, no. 8, pp. 2142–2149, Aug. 2010.
- [20] D. W. Hart, *Introduction to Power Electronics*. Englewood Cliffs, NJ: Prentice-Hall, 1997. [1] E. Figueres, G. Garcera, J. Sandia, F. Gonzalez-Espin, and J. C. Rubio,
- [21] "Sensitivity study of the dynamics of three-phase photovoltaic inverters with an LCL grid filter," *IEEE Trans. Ind. Electron.*,

vol. 56, no. 3, pp. 706–717, Mar. 2009

- [22] M. S. Elmore, "Input current ripple cancellation in synchronized, parallel connected critically continuous boost converters," in Proc. IEEE Appl. Power Electron. Conf., 1996, pp. 152–158
- [23] [24] Salmam, Fatima Zahra, Abdellah Madani, and Mohamed Kissi. "Emotion recognition from facial expression based on fiducial points detection and using Neural Network." *International Journal of Electrical and Computer Engineering (IJECE)* 8, no. 1 (2017).
- [24] [25] Saravanan, V., M. Aravindan, V. Balaji, and M. Arumugam. "Z Source Inverter Topologies-A Survey." *Bulletin of Electrical Engineering and Informatics* 6, no. 1 (2017).
- [25] [26] Annuar, K. A. M., N. A. Ab Hadi, S. K. Subramaniam, MF Mohd Ab Halim, WN Abd Rashid, A. F. Kadmin, M. S. Amri, and A. Abdul Salam. "Intelligent Image Capturing Alarm System Using Raspberry Pi." *TELKOMNIKA (Telecommunication Computing Electronics and Control)* 15, no. 4 (2017).

