



CONDITION MONITORING OF UNDERGROUND CABLE FAULT DETECTION BY USING ARDUINO

Ms. Tejashri Wable, Ms. Yeshswini Chikate, Ms. Reshama Asawale , Ms. Anjali Langhi,
Assistant Professor, Student, Student, Student
Department of Electrical Engineering,
Dr. D. Y. Patil Institute of Technology, Pimpri, Pune.

Abstract - The main objective of this project is, any distribution network is likely to get faults, on and off the supplier as well as user. Majorly a supply line can be affected by conditions of over voltage and over current, and also under voltage condition. During the event of any fault, the event goes unreported for long length of time. Manual reporting can lead to long interruption. To overcome this problem, a system is developed that will detect the changes in voltage and current guidelines, and using a micro controller based circuit. The faults can be classified based on comparison between the values received from rated guidelines of the distribution side power lines. Whenever the preset dividing line is crossed, the micro controller instantly initiates a message to the area lineman and the control station stating the exact street location where fault is happening. The real purpose of detecting fault in real time is to protect the transformer at the earliest.

Index Terms - Microcontroller, Underground, Cable, LCD, Arduino.

INTRODUCTION:

The objective of this project is to determine the distance of underground cable fault from base station in kilometers using an Arduino board. Generally we use overhead lines. We can easily identify the faults but in rushed places or familiar cities we couldn't use overhead lines. So, we are moving to underground cables. Underground cables used largely in urban area instead of overhead lines. We can't easily identify the faults in the underground cables. This project deals with arduino microcontroller, buzzer and LCD.

This proposes greatly reduces the time and operates effectively. The underground cabling system is a common practice followed in many urban areas. Many time faults occur due to construction works and other reasons. At that time it is difficult to dig out cable due to not knowing the exact location of the cable fault. arduino microcontroller, buzzer and LCD. This proposes greatly reduces the time and operates effectively.

The underground cabling system is a common practice followed in many urban areas. Many time faults occur due to construction works and other reasons. At that time it is difficult to dig out cable due to not knowing the exact location of the cable fault.

Generally we can use overhead lines. We can easily identify the faults but in rushed places we couldn't use overhead lines. So we are moving to underground cables. Underground cables used largely in urban area instead of overhead lines. We can't easily identify the faults in underground cables. This project deals with Arduino microcontroller, buzzer & LCD. This proposes greatly reduces the time and operates effectively.

LITERATURE SURVEY

[1.]Design and implementation of wireless live wire fault detector and protection in remote areas.

Raghu Raju Kalia , Preeti Abrol.

In remote areas ,the faults in live wires are difficult to analyse. So,that RF Transreceiver have been proposed for detection of faults in the live wire.

[2.]Detection and Location of Faults in 11KV Underground Cable by using Continuous Wavelet Transform (CWT).Dr.M.Suryakalavathi, B.Rabindranath Reddy, K.Prakasam, D.Prabhabathi.

This paper describes a technique to detect , classify, &locate faults on an underground cable system based on the Continuous Wavelet Transform.

[3.]Fault location in underground distribution network.

Ashish Paulose,Alan Ravi,Amal Murali,Nini John.

The system consists of a underground cable circuits for calculating more accurately the location of fault.

[4.]Underground cable fault distance locator .

Abhay Sharma,Akash Mathur,Rajat Gupta,Er.Mansi Singh.

The proposed system finds the exact location of fault.

PROPOSED SYSTEM

The proposed system is designed to track the exact location of fault occurred in the cable. This project uses ohms law concept, when a low voltage DC is applied to the feeder end through a series resistor , then the current would differ based on the location of fault occurred in the cable. In case is there any short circuit occurred from line to ground, then the voltage across series resistor alters accordingly, then it is fed to an analog to digital converter to develop exact data, which the pre-programmed Arduino UNO will display in Km.

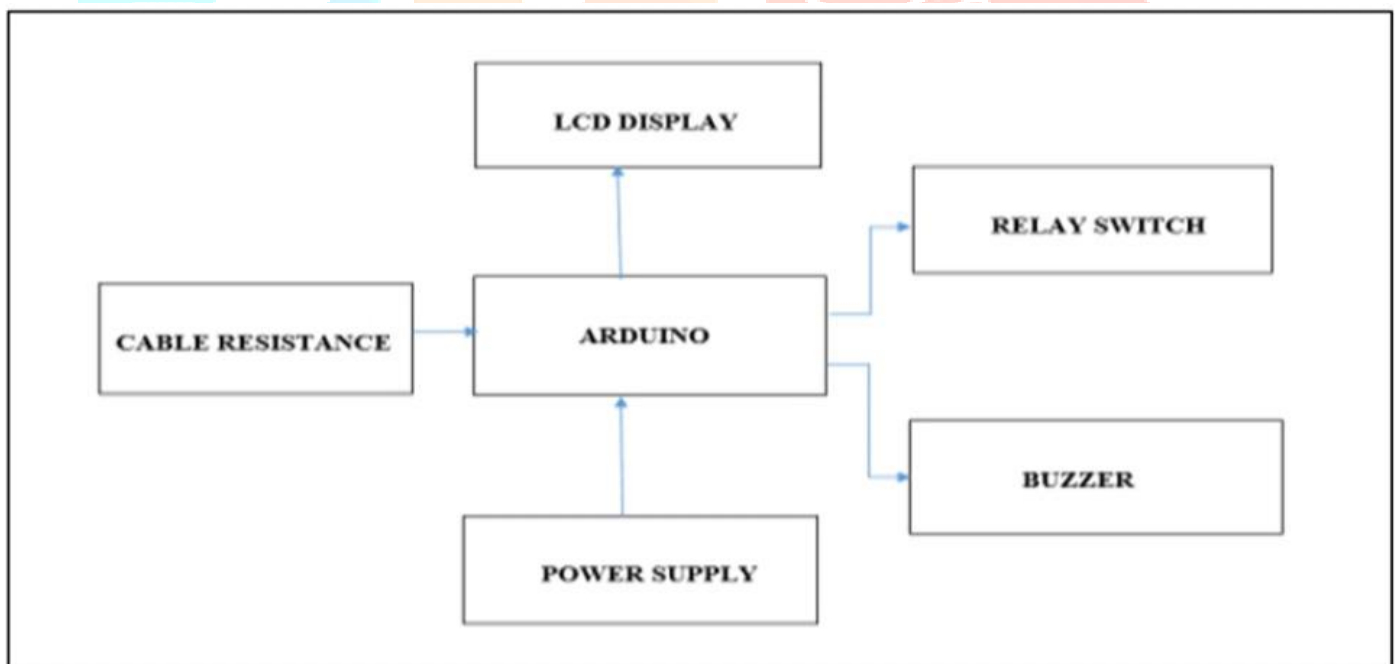

BLOCK DIAGRAM

The proposed system is designed with the set of resistors to signifying the length of cable in kilometers, and the fault creation is designed with the set of switches at every known kilometre (KM) to cross check the exactness of fault.

RESULTS AND DISCUSSION

Circuit can be tested with different resistor values to simulate various fault conditions. It displays exact location of short circuit. Similarly you can find the open circuit in a cable using capacitance measurement technique

CONCLUSION

Thus the project on Underground cable fault detection using Arduino was done and the distance of the fault from the base station in kilometers was displayed for the three individual phases R,Y and B. Circuit can be tested with different resistor values to simulate various fault conditions. The arduino microcontroller works based on the output of the cable resistance.

REFERENCES

- [1]. Raghu Raja Kalia, Preeti Abrol, 'Design and implementation of wireless live wire fault detector and protection in remote areas', IEEE,(2014),vol. 97,No.17
- [2]. B. Clegg, Underground Cable Fault Location. New York: McGraw- Hill, 1993. International Journal of Engineering Science and Computing, April 2017 6463 <http://ijesc.org/>
- [3]. M.-S. Choi, D.-S. Lee, and X. Yang, "A line to ground fault location algorithm for underground cable system," KIEE Trans. Power Eng., pp. 267–273, Jun. 2005.
- [4]. E. C. Bascom, "Computerized underground cable faultlocation expertise,"in Proc. IEEE Power Eng. Soc. General Meeting, Apr. 10–15,1994, pp. 376–382.J. Clerk Maxwell, A Treatise on Electricity and Magnetism, 3rded., vol. 2. Oxford: Clarendon, 1892, pp.68–73.
- [5]. K.K. Kuan, Prof. K. Warwick, "Real-time expert system for fault location on high voltage underground distribution cables", IEEE PROCEEDINGS-C, Vol. 139, No. 3, MAY 1992.
- [6]. Tarlochan S. Sidhu, Zhihan Xu, "Detection of Incipient Faults in Distribution Underground Cables", IEEE Transactions on Power Delivery, Vol. 25, NO. 3, JULY 2010.
- [7]. J. Densley, "Ageing mechanisms and diagnostics for power cables—an overview," IEEE Electr. Insul. Mag., vol. 17, no. 1, pp. 14–22, Jan./Feb. 2001.
- [8]. T. S. Sidhu and Z. Xu, "Detection of incipient faults in distribution underground cables", IEEE Trans. Power Del., vol. 25, no. 3, pp. 1363–1371, Jul. 2010.